



Chipsmall Limited consists of a professional team with an average of over 10 year of expertise in the distribution of electronic components. Based in Hongkong, we have already established firm and mutual-benefit business relationships with customers from,Europe,America and south Asia,supplying obsolete and hard-to-find components to meet their specific needs.

With the principle of “Quality Parts,Customers Priority,Honest Operation,and Considerate Service”,our business mainly focus on the distribution of electronic components. Line cards we deal with include Microchip,ALPS,ROHM,Xilinx,Pulse,ON,Everlight and Freescale. Main products comprise IC,Modules,Potentiometer,IC Socket,Relay,Connector.Our parts cover such applications as commercial,industrial, and automotives areas.

We are looking forward to setting up business relationship with you and hope to provide you with the best service and solution. Let us make a better world for our industry!



Contact us

Tel: +86-755-8981 8866 Fax: +86-755-8427 6832

Email & Skype: info@chipsmall.com Web: www.chipsmall.com

Address: A1208, Overseas Decoration Building, #122 Zhenhua RD., Futian, Shenzhen, China



ADNK-6033-ND24

USB 2.4GHz RF Wireless Laser Mouse Designer's Kit



Product Overview

Description

Avago Technologies, Texas Instruments and Nordic Semiconductor have joined forces to produce a new wireless laser mouse reference design kit. Based on the new Avago Technologies ADNS-6030 low power laser mouse sensor, Texas Instruments MSP430F1222 microcontroller, Nordic Semiconductor nRF2402 2.4GHz RF transmitter and nRF2401A 2.4GHz RF transceiver, Cypress CY7C63231A enCoRe™ USB microcontroller, this reference design kit provides a power efficient and feature-rich solution in one neat package.

The Avago Technologies ADNS-6030 low power laser mouse sensor, an 18-pin staggered dual inline package (DIP), is based on LaserStream Technology, which measures changes in position by optically acquiring sequential surface images (frames) and mathematically determining the direction and magnitude of movement. Its high-performance, low power architecture is capable of sensing high-speed mouse motion while prolonging battery life, two performance areas essential in demanding wireless applications.

The ADNS-6030 sensor along with the ADNS-6120 or ADNS-6130-001 lens, ADNS-6230-001 clip and ADNV-6340 VCSEL form a complete and compact laser mouse tracking system. There is no moving part, which means high reliability and less maintenance for the end user. In addition, precision optical alignment is not required, facilitating high volume assembly.

Features

- Complete laser mouse reference design kit
- Windows® 98SE, Windows 2000 and Windows XP compatibility
- USB 2.0 low-speed compliance
- User identity code to avoid conflict with other devices
- High reliability
- New LaserStream Technology
- Smooth surface navigation
- Enhanced *SmartSpeed* self-adjusting frame rate for optimum performance
- High speed motion detection up to 20 ips and 8G
- 800 cpi resolution
- No mechanical moving parts
- A high data rate 2.4GHz RF link
- Transmission data rate up to 1 Mbps
- 15 meters communication distance
- Self-adjusting power-saving modes for longest battery life
- Laser fault detect circuitry on-chip for Eye Safety Compliance
- Minimal number of passive components

The Texas Instruments MSP430F1222 is the ultra low-power mixed signal microcontroller with a built-in 16-bit timer, 10-bit A/D converter with integrated reference and data transfer controller (DTC) and twenty-two I/O pins. In addition, the MSP430F1222 microcontroller has built-in communication capability using asynchronous (UART) and synchronous (SPI) protocols. The architecture, combined with five low power modes is optimized to achieve extended battery life on wireless application.

The Nordic nRF2402 and nRF2401A are the low power single-chip radio transmitter and transceiver for the world wide 2.4 - 2.5 GHz ISM band. The entire transmitter and transceiver including all inductors and filters are integrated in each single chip respectively which gives the lowest cost solution to the end user. All configurations of the nRF2402 transmitter and nRF2401A transceiver are done via a standard serial interface. The nRF devices include the ShockBurst engine which allow for high datarates on air using low datarates between the microcontroller and the nRF device, it will also au-

tomatically validate the packets adress and CRC, further reducing the microcontrollers processing tasks.

The Cypress CY7C63231A enCoRe™ is a revolutionary chip that integrates numerous common components, including breakthrough crystal-less oscillator. The result is an overall reduction in board components and reduced system cost. The EPROM based microcontroller allows easy firmware modification, as well as storage of Vendor and Product ID™s without an external EEPROM.

This kit is connectable to a PC via the USB port. It is based on the 2.4GHz RF technology, the data generated from displacement detection / button status in the laser mouse is encoded with a pre-defined serial type protocol handled by firmware in the MCU. In the RF stage, the encoded data is used for GFSK modulation. The captured data from the RF receiver stage is decoded with a corresponding packet format used for mouse applications. The final data is sent to the host through the USB interface.

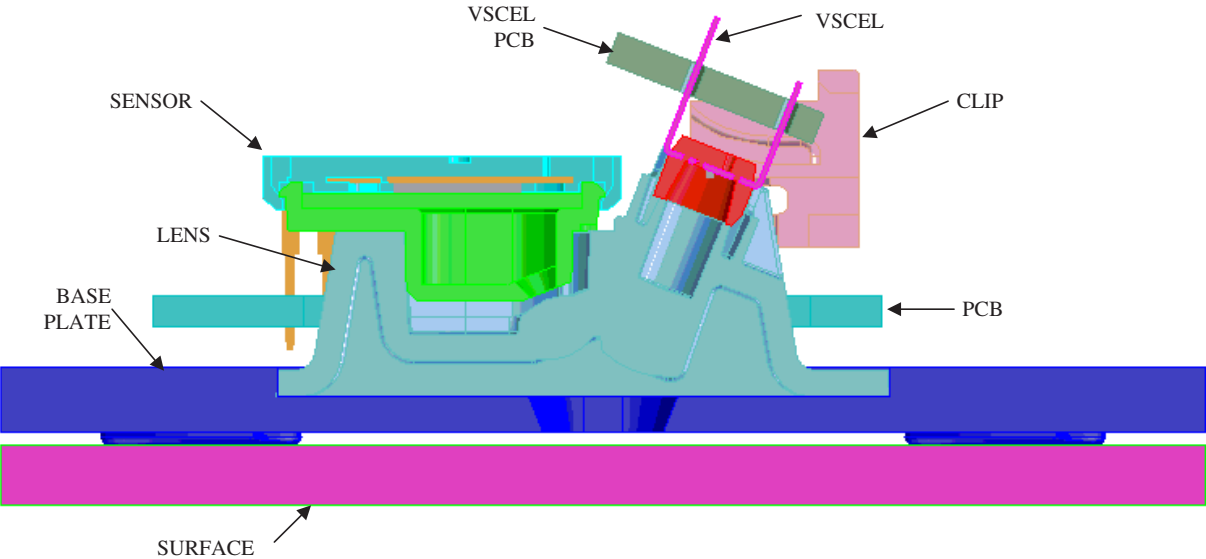

Figure 1. Sectional view of PCB assembly highlighting all optical mouse components (optical mouse sensor, clip, lens, LASER, PCB, and base plate).

Schematic Design of Overall Circuit

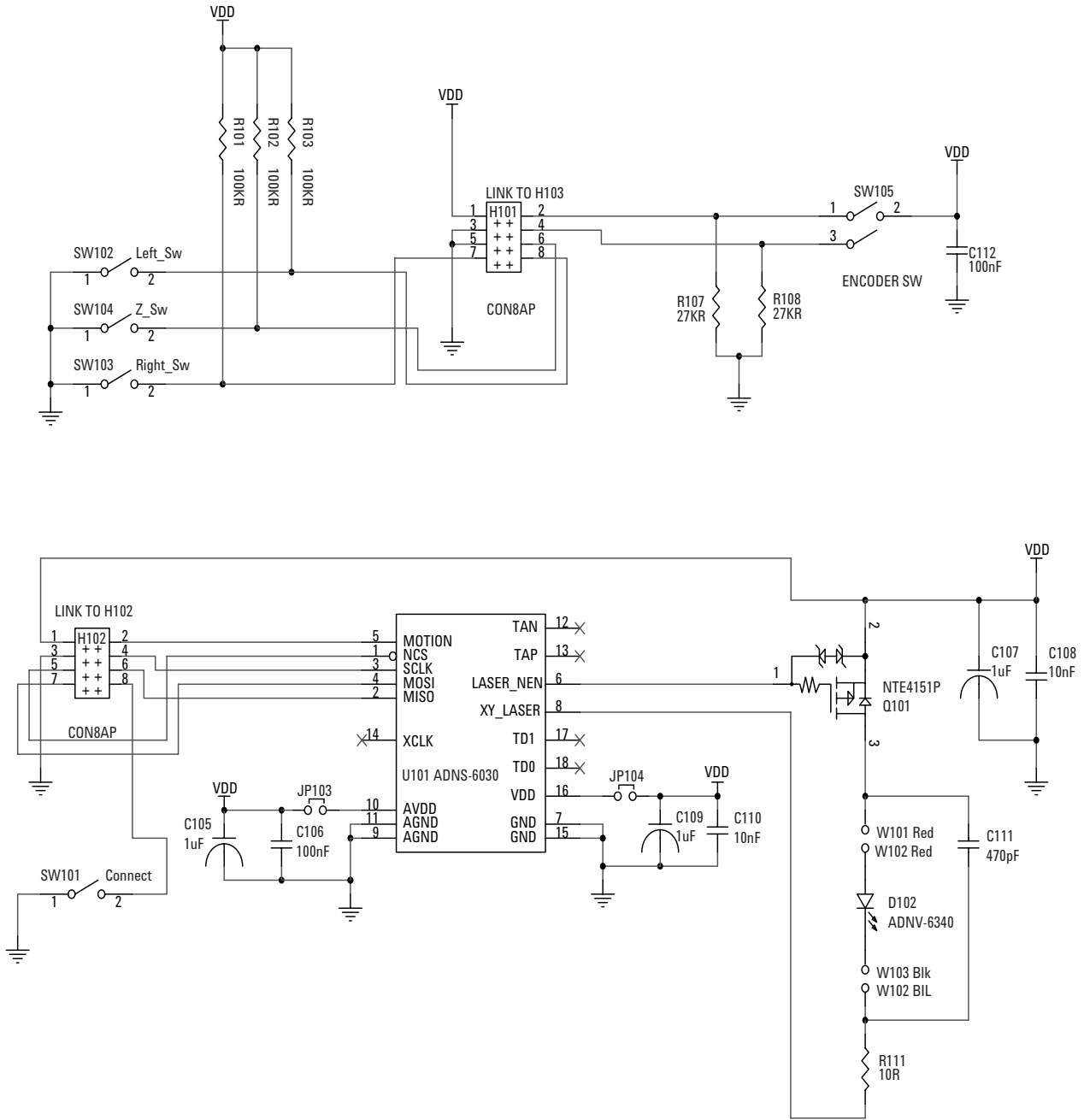

Figure 2. Circuit diagram of ADNS-6030 sensor, buttons and Z-wheel schematic in ADNK-6033-ND24 designer's kit wireless laser mouse

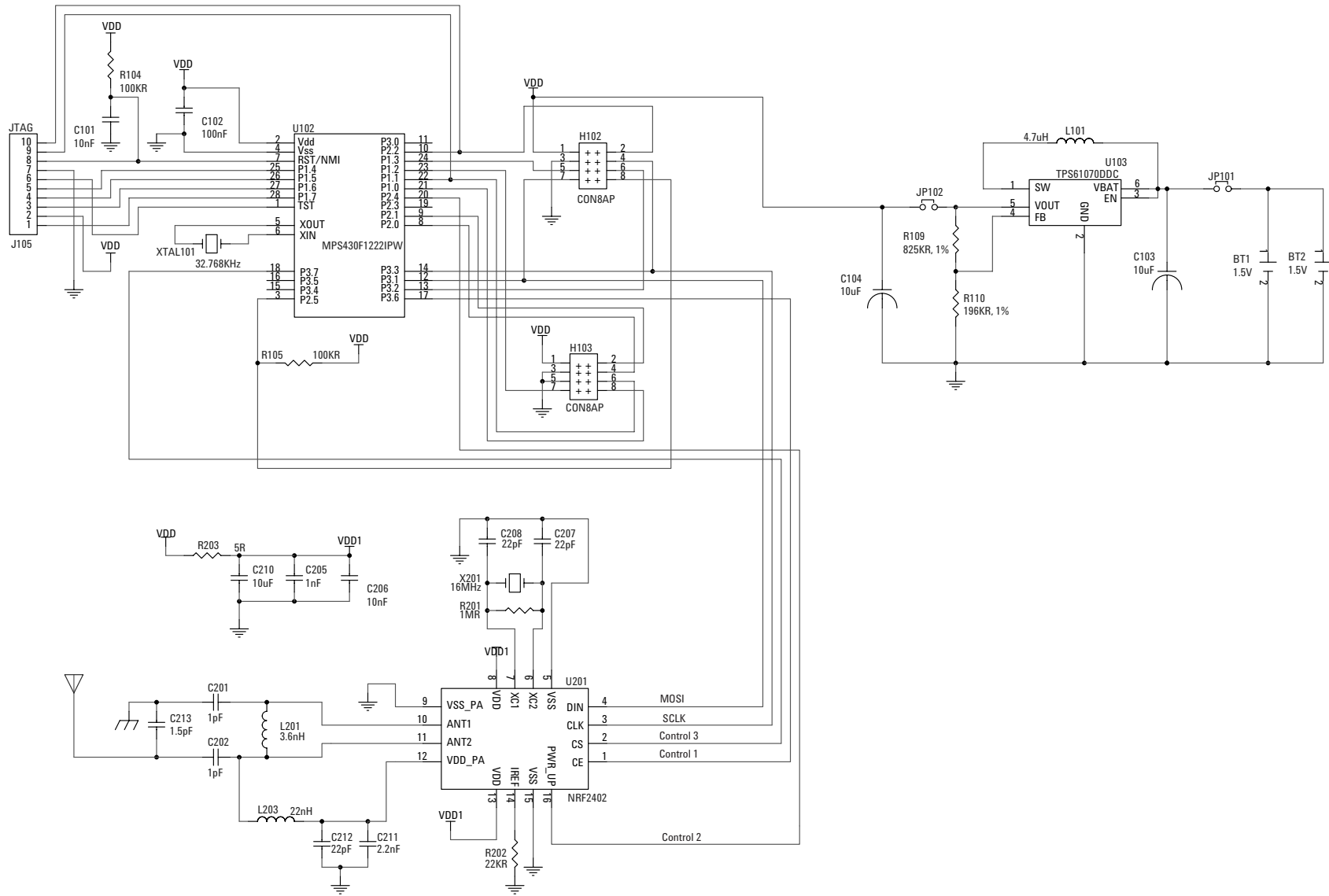

Figure 3. Circuit diagram of MSP430F1222 microcontroller and nRF2402 transmitter in ADNK-6033-ND24 designer's kit wireless laser mouse

Kit Components

The designer's kit contains components as follows:

Part Number	Description	Name	Quantity
ADNK-6033-ND24 Mouse Set	a. Wireless Laser Mouse b. USB Dongle	Reference Design Mouse Set	1
ADNS-6030	Laser Mouse Sensor	Sensor	5
ADNS-6120	Laser Mouse Round Lens Plate	Lens	5
ADNS-6130-001	Laser Mouse Trim Lens Plate	Lens	5
ADNS-6230-001	Laser Mouse VCSEL Assembly Clip	VCSEL Clip	5
ADNV-6340	Single Mode Vertical Cavity Surface Emitting Laser	VCSEL	5
ADNK-6033-ND24 CD-ROM	Includes Documentation and Support Files for ADNK-6033-ND24 Documentations a. ADNB-6031-EV and ADNB-6032-EV Low Power Laser Mouse Bundles Data Sheet b. ADNK-6033-ND24 Laser Mouse Designer's Kit Product Overview c. ADNK-6033-ND24 Laser Mouse Designer's Kit Design Guide d. Avago Technologies ADNB-6031 and ADNB-6032 Laser Mouse Eye Safety Calculation Application Note 5230 e. Texas Instrument MSP430F1222 Microcontroller Datasheet f. Nordic Semiconductor nRF2401A RF Transceiver Datasheet g. Nordic Semiconductor nRF2402 RF Transmitter Datasheet Hardware Support Files a. ADNK-6033-ND24 BOM List b. ADNK-6033-ND24 Schematic c. ADNK-6033-ND24 Gerber File d. IGES Base Plate Feature File Software Support Files a. Microcontroller Firmware		

Ordering Information

For ordering information, please contact your local Avago Technologies sales representative.

Avago Technologies' Partners

For partner product information and list of distributors, please go to their respective website.



www.nordicsemi.com
Nordic Semiconductor Support
Tel: +47 72 89 89 00
www.nordicsemi.no/sup_com/pro.php



www.ti.com
TI Semiconductor Product Information
Center
support.ti.com

For product information and a complete list of distributors, please go to our web site: www.avagotech.com

Avago, Avago Technologies, and the A logo are trademarks of Avago Technologies, Pte. in the United States and other countries.
Data subject to change. Copyright © 2006 Avago Technologies Pte. All rights reserved. Obsoletes 5989-3605EN
AV01-0280EN - July 4, 2006

