



Chipsmall Limited consists of a professional team with an average of over 10 year of expertise in the distribution of electronic components. Based in Hongkong, we have already established firm and mutual-benefit business relationships with customers from,Europe,America and south Asia,supplying obsolete and hard-to-find components to meet their specific needs.

With the principle of “Quality Parts,Customers Priority,Honest Operation,and Considerate Service”,our business mainly focus on the distribution of electronic components. Line cards we deal with include Microchip,ALPS,ROHM,Xilinx,Pulse,ON,Everlight and Freescale. Main products comprise IC,Modules,Potentiometer,IC Socket,Relay,Connector.Our parts cover such applications as commercial,industrial, and automotives areas.

We are looking forward to setting up business relationship with you and hope to provide you with the best service and solution. Let us make a better world for our industry!



## Contact us

Tel: +86-755-8981 8866 Fax: +86-755-8427 6832

Email & Skype: info@chipsmall.com Web: www.chipsmall.com

Address: A1208, Overseas Decoration Building, #122 Zhenhua RD., Futian, Shenzhen, China



### FEATURES

- Input voltage range:** 1.6 V to 3.6 V
- Output current range:** 0 mA to 300 mA
- Output voltage accuracy:**  $\pm 1\%$
- Operating temperature range:**  $-40^{\circ}\text{C}$  to  $+125^{\circ}\text{C}$

### GENERAL DESCRIPTION

The ADP170/ADP171 evaluation board is used to demonstrate the functionality of the ADP170/ADP171 linear regulators.

Simple device measurements such as line and load regulation, dropout, and ground current can be demonstrated with just a single voltage supply, a voltmeter, a current meter, and load resistors.

For more details about the ADP170/ADP171 linear regulators, visit [www.analog.com](http://www.analog.com).

### EVALUATION BOARD

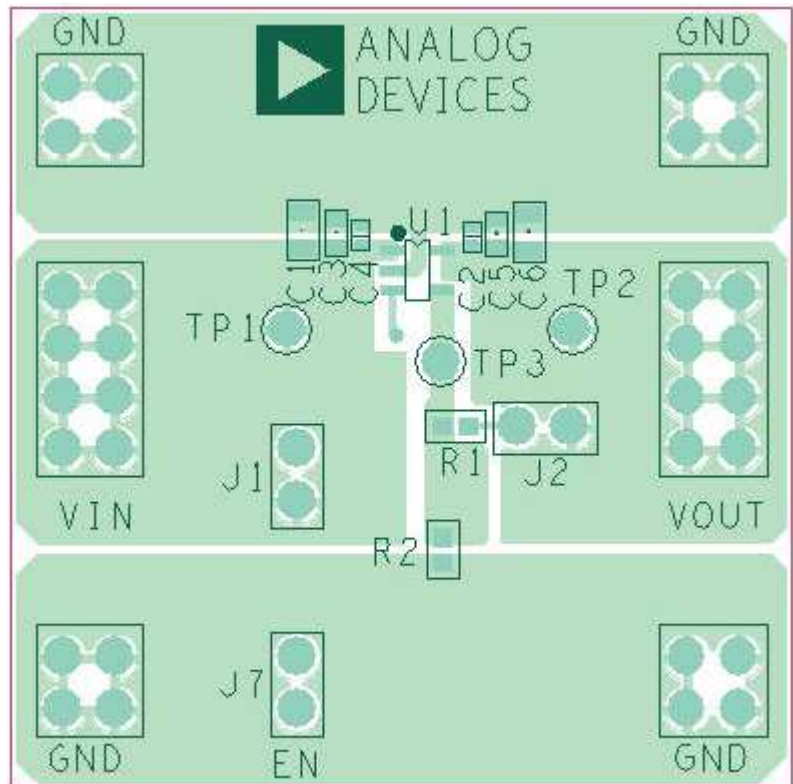

Figure 1. 5-Lead TSOT Layout

### Rev. 0

Evaluation boards are only intended for device evaluation and not for production purposes. Evaluation boards are supplied "as is" and without warranties of any kind, express, implied, or statutory including, but not limited to, any implied warranty of merchantability or fitness for a particular purpose. No license is granted by implication or otherwise under any patents or other intellectual property by application or use of evaluation boards. Information furnished by Analog Devices is believed to be accurate and reliable. However, no responsibility is assumed by Analog Devices for its use, nor for any infringements of patents or other rights of third parties that may result from its use. Analog Devices reserves the right to change devices or specifications at any time without notice. Trademarks and registered trademarks are the property of their respective owners. Evaluation boards are not authorized to be used in life support devices or systems.

## TABLE OF CONTENTS

Features .....	1	Load Regulation .....	5
General Description .....	1	Dropout Voltage .....	5
Evaluation Board .....	1	Ground Current Measurements .....	6
Revision History .....	2	Ground Current Consumption .....	7
Evaluation Board Hardware and Schematics.....	3	Ordering Information.....	8
Evaluation Board Configurations .....	3	Bill of Materials.....	8
Output Voltage Measurements .....	4	Ordering Guide .....	8
Line Regulation.....	5	ESD Caution.....	8

## REVISION HISTORY

1/09—Revision 0: Initial Version

## EVALUATION BOARD HARDWARE AND SCHEMATICS

### EVALUATION BOARD CONFIGURATIONS

The ADP170/ADP171 evaluation boards come supplied with different components, depending on which version is ordered. Components common to all versions are C1 through C6 and J1. The J2, R1, and R2 components are populated on the adjustable ADP171 version only; these components are not populated on the ADP170. C1, C3, and C4 are input capacitors, and C2, C5, and C6 are output capacitors. These capacitors have different size footprints to facilitate evaluating the regulator using a wide variety of components. Figure 2 shows the schematic of ADP170 evaluation board configuration. Figure 3 shows the schematic of ADP171 evaluation board configuration.

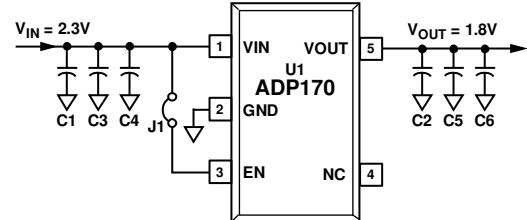

Figure 2. ADP170 Evaluation Board Schematic

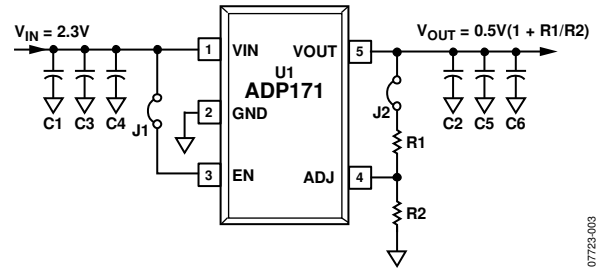

Figure 3. ADP171 Evaluation Board Schematic

Table 1. Evaluation Board Hardware Components

Component	Function	Description
U1 <sup>1</sup>	Linear regulator	ADP170/ADP171 low dropout linear regulator.
C1	0805 size input capacitor	Not populated.
C2	0402 size output capacitor	Not populated.
C3	0603 size input capacitor	1 $\mu$ F input bypass capacitor.
C4	0402 size input capacitor	Not populated.
C5	0603 size output capacitor	1 $\mu$ F output capacitor. Required for stability and transient performance.
C6	0805 size input capacitor	Not populated.
J1	Jumper	Jumper. Connects EN to VIN for automatic startup.
J2	Jumper	Jumper. Connects the VOUT to the resistor feedback network.
TP1	Test point	Test point closest to VIN pin.
TP2	Test point	Test point closest to VOUT pin.

<sup>1</sup> Component depends on the evaluation board type ordered.

## OUTPUT VOLTAGE MEASUREMENTS

Figure 4 shows how the evaluation board can be connected to a voltage source and a voltmeter for basic measurements of the output voltage accuracy. A resistor can be used as the load for the regulator. Ensure that the resistor has an adequate power rating for handling the power expected to be dissipated across it. An electronic load can also be used as an alternative. Ensure that the voltage source can supply enough current for the expected load levels.

Use the following steps to connect to a voltage source and voltmeter:

1. Connect the negative terminal (–) of the voltage source to one of the GND pads on the evaluation board.
2. Connect the positive terminal (+) of the voltage source to the VIN pad of the evaluation board.
3. Connect a load between the VOUT pad and one of the GND pads.

4. Connect the negative terminal (–) of the voltmeter to one of the GND pads.
5. Connect the positive terminal (+) of the voltmeter to the pad closest to the VOUT pin.

The voltage source can then be turned on. If J1 is inserted (which connects EN to VIN for automatic startup), the regulator powers up. For ADP170, Jumper J2 need not be inserted as shown in Figure 4. The current from the external resistor divider network when there is adjustable voltage output (as with the ADP171) should be subtracted from the ground current measured.

If the load current is large, the user must connect the voltmeter as close as possible to the output capacitor to reduce the effects of IR drops due to trace resistance.

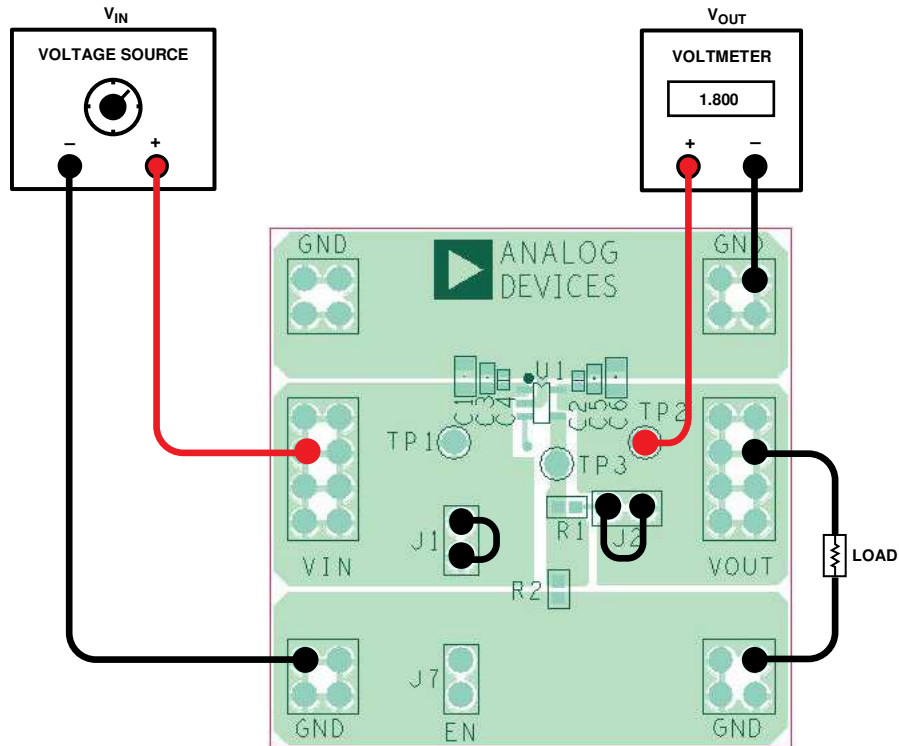

Figure 4. Configuration for Output Voltage Measurements

07723-004

### LINE REGULATION

For line regulation measurements, the output of the regulator is monitored while its input varies. For good line regulation, the output ( $V_{OUT}$ ) must change as little as possible with varying input ( $V_{IN}$ ) levels. To ensure that the device is not in dropout during this measurement,  $V_{IN}$  must be varied between  $V_{OUTNOM} + 0.5\text{ V}$  (or  $1.6\text{ V}$ , whichever is greater) and  $V_{INMAX}$ . For example, for an ADP170 with fixed  $1.8\text{ V}$  output,  $V_{IN}$  needs to be varied between  $2.3\text{ V}$  and  $5.5\text{ V}$ . This measurement can be repeated under different load conditions. Figure 5 shows the typical line regulation performance of an ADP170 with fixed  $1.8\text{ V}$  output.

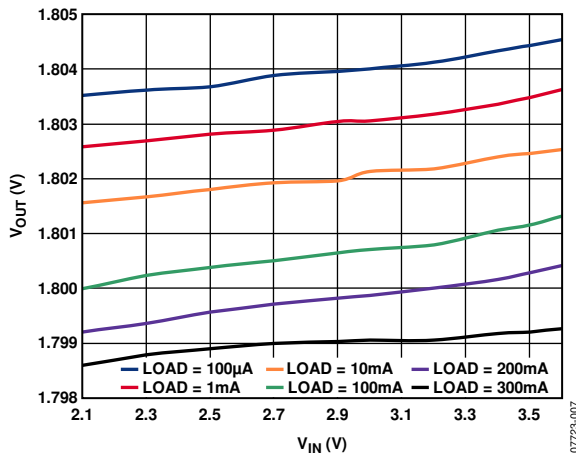

Figure 5. Output Voltage vs. Input Voltage

### LOAD REGULATION

For load regulation measurements, the output of the regulator is monitored while the load varies. For good load regulation, the output must change as little as possible with varying load current. The input voltage must be held constant during this measurement. The load current can be varied from  $0\text{ mA}$  to  $150\text{ mA}$ . Figure 6 shows the typical load regulation performance of an ADP170 with fixed  $1.8\text{ V}$  output for an input voltage of  $2.3\text{ V}$ .

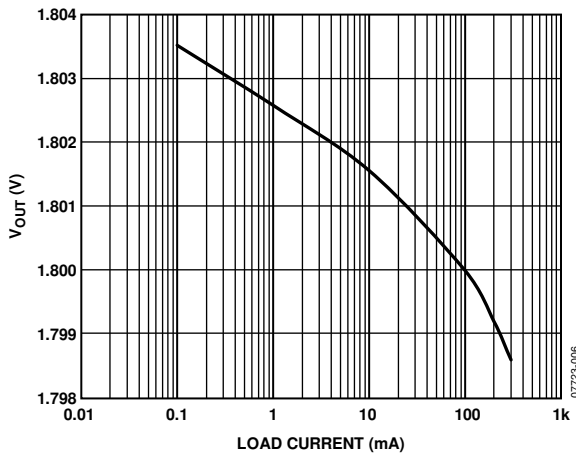

Figure 6. Output Voltage vs. Load Current

### DROPOUT VOLTAGE

Dropout voltage can be measured using the configuration shown in Figure 4. Dropout voltage is defined as the input-to-output voltage differential when the input voltage is set to the nominal output voltage. This applies only for output voltages greater than  $1.6\text{ V}$ . Dropout voltage increases with larger loads. For more accurate measurements, use a second voltmeter to monitor the input voltage across the input capacitor. The input supply voltage may need to be adjusted to account for IR drops due to trace resistance, especially if large load currents are used. Figure 7 shows a typical curve of dropout voltage measurements with different load currents.

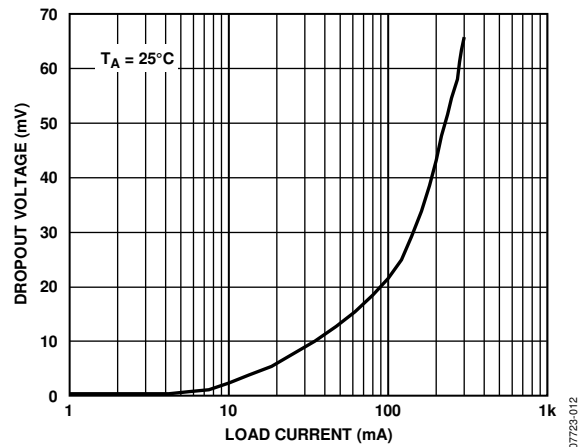

Figure 7. Dropout Voltage vs. Load Current

## GROUND CURRENT MEASUREMENTS

Figure 8 shows how the evaluation board can be connected to a voltage source and an ammeter to measure ground currents. A resistor can be used as the load for the regulator. Ensure that the resistor has an adequate power rating for handling the power expected to be dissipated across it. An electronic load can be used as an alternative. Ensure that the voltage source used can supply enough current for the expected load levels.

Use the following steps to connect to a voltage source and ammeter:

1. Connect the positive terminal (+) of the voltage source to the VIN pad on the evaluation board.

2. Connect the positive terminal (+) of the ammeter to one of the GND pads of the evaluation board.
3. Connect the negative terminal (-) of the ammeter to the negative (-) terminal of the voltage source.
4. Connect a load between the negative (-) terminal of the voltage source and the pad closest to the VOUT pin of the evaluation board.

The voltage source can then be turned on. If J1 is inserted (which connects EN to VIN for automatic startup), the regulator powers up. For ADP170, Jumper J2 need not be inserted as shown in Figure 8.

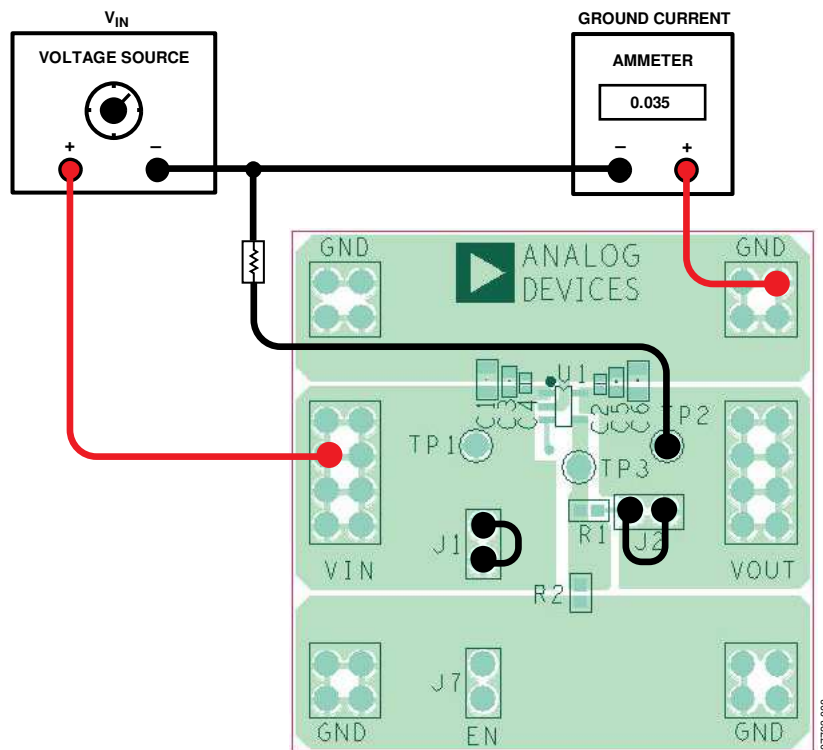

Figure 8. Configuration for Ground Current Measurements

## GROUND CURRENT CONSUMPTION

Ground current measurements can determine how much current the internal circuits of the regulator are consuming while the circuits perform the regulation function. To be efficient, the regulator needs to consume as little current as possible. Typically, the regulator uses the maximum current when supplying its largest load level (300 mA). Figure 9 shows the typical ground current consumption for various load levels at an input voltage of 2.3 V. When the device is disabled (EN = GND), the ground current drops to less than 1  $\mu\text{A}$ .

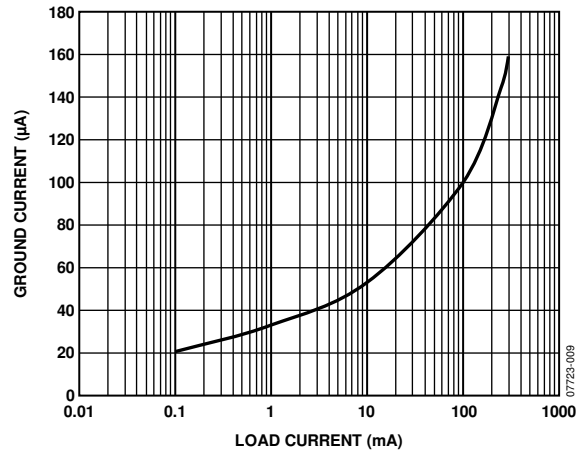

Figure 9. Ground Current vs. Load Current



# EVAL-ADP170/ADP171

## ORDERING INFORMATION

### BILL OF MATERIALS

Table 2.

Qty	Reference Designator	Description	Manufacturer/Vendor	Vendor Part No.
2	C1, C2	Capacitor, MLCC, 1 $\mu$ F, 10 V, 0603, X5R	Murata or equivalent	GRM188R61A105KA61
1	J1	Header, single, STR, two pins	Digi-Key Corp.	S1012E-36-ND
1	U1	IC, LDO regulator	Analog Devices, Inc.	ADP170/ADP171 <sup>1</sup>

<sup>1</sup> Component depends on the evaluation board type ordered.

### ORDERING GUIDE

Model	Output Voltage (V)	Description
ADP170-1.8-EVALZ <sup>1</sup>	1.8	Evaluation Board
ADP171-EVALZ <sup>1</sup>	1.0	Evaluation Board

<sup>1</sup> Z = RoHS Compliant Part.

### ESD CAUTION



**ESD (electrostatic discharge) sensitive device.**

Charged devices and circuit boards can discharge without detection. Although this product features patented or proprietary protection circuitry, damage may occur on devices subjected to high energy ESD. Therefore, proper ESD precautions should be taken to avoid performance degradation or loss of functionality.