



Chipsmall Limited consists of a professional team with an average of over 10 year of expertise in the distribution of electronic components. Based in Hongkong, we have already established firm and mutual-benefit business relationships with customers from,Europe,America and south Asia,supplying obsolete and hard-to-find components to meet their specific needs.

With the principle of “Quality Parts,Customers Priority,Honest Operation,and Considerate Service”,our business mainly focus on the distribution of electronic components. Line cards we deal with include Microchip,ALPS,ROHM,Xilinx,Pulse,ON,Everlight and Freescale. Main products comprise IC,Modules,Potentiometer,IC Socket,Relay,Connector.Our parts cover such applications as commercial,industrial, and automotives areas.

We are looking forward to setting up business relationship with you and hope to provide you with the best service and solution. Let us make a better world for our industry!



## Contact us

Tel: +86-755-8981 8866 Fax: +86-755-8427 6832

Email & Skype: info@chipsmall.com Web: www.chipsmall.com

Address: A1208, Overseas Decoration Building, #122 Zhenhua RD., Futian, Shenzhen, China



## FEATURES

**Combined gyroscope and dual-axis, low  $g$  accelerometer**  
**Temperature compensated, high precision bias, and sensitivity performance**  
 **$\pm 30$  mg accelerometer bias stability over temperature**  
 **$\pm 2^\circ/\text{sec}$  gyroscope null stability over temperature**  
**2.5 mg rms typical accelerometer noise at 35.6 Hz**  
 **$0.1^\circ/\text{sec}$  rms typical gyroscope noise at 35.6 Hz**  
**Gyroscope: linear acceleration rejection of  $0.03^\circ/\text{sec}/g$**   
**Acceleration:  $\pm 32$  g overload performance**  
**SPI digital output with a 16-bit data-word and a 4-bit CRC**  
**Comprehensive electromechanical fail-safe features**  
**6 kHz data update rate**  
**Programmable filter response**  
**<16 mA quiescent current draw**  
**3.3 V or 5 V operation**  
 **$-40^\circ\text{C}$  to  $+105^\circ\text{C}$  temperature range**  
**16-lead inverted cavity SOIC package for robust EMI performance**  
**Qualified for automotive applications**

## APPLICATIONS

**Electronic stability control**  
**Chassis control**

## GENERAL DESCRIPTION

The **ADXC1500** is a yaw rate gyroscope and dual-axis accelerometer combined in a single package. It is designed for electronic stability control (ESC) and other high performance applications that require yaw rate and acceleration signals simultaneously. An internal temperature sensor compensates offset and sensitivity performance, providing excellent stability over the  $-40^\circ\text{C}$  to  $+105^\circ\text{C}$  temperature range.

A digital serial port interface (SPI) transmits the yaw rate and acceleration data to a host microcontroller. A 4-bit cyclical redundancy check (CRC) provides fault coverage for the transmitted SPI data, and internal fault detection routines ensure the integrity of all reported yaw rates and acceleration data. A fully integrated electromechanical continuous self test (CST) routine provides run-time diagnostic capability for assessing the health of each MEMS element.

An advanced gyroscope sensor design rejects the linear acceleration effects of shock and vibration, enabling the **ADXC1500** to operate in harsh environments. The accelerometer signal chain is designed to prevent overload conditions from occurring in these same harsh environments.

The **ADXC1500** is designed to operate at either 3.3 V or 5 V. At less than 16 mA current consumption, the **ADXC1500** can be used in energy sensitive applications.

## FUNCTIONAL BLOCK DIAGRAM

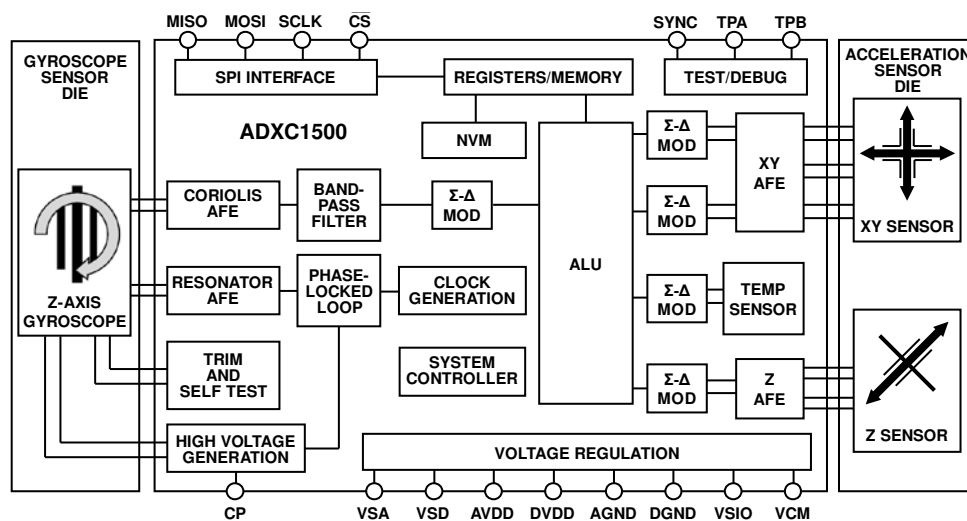

Figure 1.

For more information about the **ADXC1500**, contact the Analog Devices, Inc., *Customer Interaction Center* at [http://www.analog.com/technical\\_support](http://www.analog.com/technical_support) to connect with a technical support specialist.

Rev. SpC

[Document Feedback](#)

Information furnished by Analog Devices is believed to be accurate and reliable. However, no responsibility is assumed by Analog Devices for its use, nor for any infringements of patents or other rights of third parties that may result from its use. Specifications subject to change without notice. No license is granted by implication or otherwise under any patent or patent rights of Analog Devices. Trademarks and registered trademarks are the property of their respective owners.

One Technology Way, P.O. Box 9106, Norwood, MA 02062-9106, U.S.A.  
 Tel: 781.329.4700 ©2016–2018 Analog Devices, Inc. All rights reserved.  
[Technical Support](#) [www.analog.com](http://www.analog.com)

**NOTES**