



Chipsmall Limited consists of a professional team with an average of over 10 year of expertise in the distribution of electronic components. Based in Hongkong, we have already established firm and mutual-benefit business relationships with customers from,Europe,America and south Asia,supplying obsolete and hard-to-find components to meet their specific needs.

With the principle of “Quality Parts,Customers Priority,Honest Operation,and Considerate Service”,our business mainly focus on the distribution of electronic components. Line cards we deal with include Microchip,ALPS,ROHM,Xilinx,Pulse,ON,Everlight and Freescale. Main products comprise IC,Modules,Potentiometer,IC Socket,Relay,Connector.Our parts cover such applications as commercial,industrial, and automotives areas.

We are looking forward to setting up business relationship with you and hope to provide you with the best service and solution. Let us make a better world for our industry!



Contact us

Tel: +86-755-8981 8866 Fax: +86-755-8427 6832

Email & Skype: info@chipsmall.com Web: www.chipsmall.com

Address: A1208, Overseas Decoration Building, #122 Zhenhua RD., Futian, Shenzhen, China



Blackfin[®] EZ-Extender[®] Manual

Revision 4.1, July 2012

Part Number
82-000735-01

Analog Devices, Inc.
One Technology Way
Norwood, Mass. 02062-9106



Copyright Information

© 2012 Analog Devices, Inc., ALL RIGHTS RESERVED. This document may not be reproduced in any form without prior, express written consent from Analog Devices, Inc.

Printed in the USA.

Disclaimer

Analog Devices, Inc. reserves the right to change this product without prior notice. Information furnished by Analog Devices is believed to be accurate and reliable. However, no responsibility is assumed by Analog Devices for its use; nor for any infringement of patents or other rights of third parties which may result from its use. No license is granted by implication or otherwise under the patent rights of Analog Devices, Inc.

Trademark and Service Mark Notice

The Analog Devices logo, Blackfin, CrossCore, EngineerZone, EZ-Extender, EZ-KIT Lite, and VisualDSP++ are registered trademarks of Analog Devices, Inc.

All other brand and product names are trademarks or service marks of their respective owners.

Regulatory Compliance

The Blackfin EZ-Extender is designed to be used solely in a laboratory environment. The board is not intended for use as a consumer end product or as a portion of a consumer end product. The board is an open system design which does not include a shielded enclosure and therefore may cause interference to other electrical devices in close proximity. This board should not be used in or near any medical equipment or RF devices.

The Blackfin EZ-Extender has been certified to comply with the essential requirements of the European EMC directive 89/336/EEC (inclusive 93/68/EEC) and, therefore, carries the “CE” mark.

The Blackfin EZ-Extender has been appended to Analog Devices, Inc. EMC Technical File (EMC TF) referenced “DSPTOOLS1” dated December 21, 1997 and was declared CE compliant by an appointed Notified Body (No.0673) as listed below.

Notified Body Statement of Compliance: Z600ANA1.017



Issued by: Technology International (Europe) Limited
56 Shrivenham Hundred Business Park
Shrivenham, Swindon, SN6 8TY, UK

The Blackfin EZ-Extender contains ESD (electrostatic discharge) sensitive devices. Electrostatic charges readily accumulate on the human body and equipment and can discharge without detection. Permanent damage may occur on devices subjected to high-energy discharges. Proper ESD precautions are recommended to avoid performance degradation or loss of functionality. Store unused extender boards in the protective shipping package.



CONTENTS

PREFACE

Product Overview	viii
Purpose of This Manual	ix
Intended Audience	ix
Manual Contents	x
What's New in This Manual	x
Technical Support	xi
Supported Products	xii
Product Information	xii
Analog Devices Web Site	xii
EngineerZone	xiii
Related Documents	xiv

EZ-EXTENDER INTERFACES

ADC and Mixed-Signal HSC Interface	1-1
DAC HSC Interface	1-2
Camera Interface	1-3
LCD Interface	1-4

Contents

EZ-EXTENDER HARDWARE REFERENCE

System Architecture	2-1
DIP Switches and Jumpers	2-4
Direction Control Switch (SW1)	2-4
Clock Routing Switch (SW2)	2-5
General Frame Sync Routing Switch (SW3)	2-7
LCD Frame Sync Routing Switch (SW4)	2-8
MISO Disconnect Jumper (P7)	2-9
SMA Connector Clock Disconnect Jumper (P10)	2-9
PPI Data Routing Jumper (P36)	2-10
External Clock Disable Jumper (P37)	2-11

EZ-EXTENDER BILL OF MATERIALS

EZ-EXTENDER SCHEMATIC

INDEX

PREFACE

Thank you for purchasing the Blackfin EZ-Extender®, Analog Devices (ADI) extender board to the EZ-KIT Lite® evaluation system for ADSP-BF533 and ADSP-BF561 Blackfin® processors.

The Blackfin processors are embedded processors that support a Media Instruction Set Computing (MISC) architecture. This architecture is the natural merging of RISC, media functions, and digital signal processing (DSP) characteristics towards delivering signal processing performance in a microprocessor-like environment.

The Blackfin EZ-Extender is designed to be used in conjunction with the CrossCore® Embedded Studio (CCES) and VisualDSP++® software development environments. The development environment facilitates advanced application code development and debug, such as:

- Create, compile, assemble, and link application programs written in C++, C, and Blackfin EZ-Extender assembly
- Load, run, step, halt, and set breakpoints in application programs
- Read and write data and program memory
- Read and write core and peripheral registers
- Plot memory

To learn more about Analog Devices development software, go to <http://www.analog.com/processors/tools>.

Example programs are available to demonstrate the capabilities of the Blackfin EZ-Extender board.

Product Overview

The Blackfin EZ-Extender is a separately sold assembly that plugs onto the expansion interface of the ADSP-BF533/BF561 EZ-KIT Lite evaluation system.

The board extends the capabilities of the evaluation system by providing a connection between the parallel peripheral interface (PPI) of the ADSP-BF533 processor (the PPI0 and PPI1 interfaces of the ADSP-BF561 processor), an Analog Devices high-speed converter (HSC) evaluation board, a camera evaluation board, and an LCD display device. Moreover, the extender broadens the range of the EZ-KIT Lite applications by providing surface mounted (SMT) footprints for breadboard capabilities and access to all of the pins on the EZ-KIT Lite's expansion interface.

Please visit www.analog.com/EX1-Extender for additional information, including CCES support.

The extender features:

- High-speed converter (HSC) evaluation board interface
 - 40-pin, right angle, 0.1 in. spacing, female socket to connect to analog-to-digital converter (ADC) boards
 - 40-pin straight, 0.1 in. spacing header to connect to digital-to-analog converter (DAC) boards
 - Switches for routing and direction selection
 - RJ-45 with serial peripheral interconnect (SPI) to configure converter registers

- Camera interface
 - Connection to OmniVision OV6630AA evaluation boards (This part is no longer available.)
 - 32-pin, right angle, 0.1 in. spacing, female socket
- LCD interface
 - 32-pin, right angle FLZ-type connector to connect to LCD displays
- SMT footprint area
 - 1206 and 805 footprints
 - SOIC24 and SOIC20 footprints
- Dimensions
 - 5 in (H) x 5 in (W)

Purpose of This Manual

The *Blackfin EZ-Extender Manual* describes the operation and configuration of the components on the board. A schematic and a bill of materials are provided as a reference for future ADSP-BF533 and ADSP-BF561 Blackfin processor board designs.

Intended Audience

This manual is a user's guide and reference to the Blackfin EZ-Extender. Programmers who are familiar with the Analog Devices Blackfin processor architecture, operation, and development tools are the primary audience for this manual.

Manual Contents

Programmers who are unfamiliar with Analog Devices processors can use this manual but should supplement it with other texts that describe your target architecture. For the locations of these documents, see [“Related Documents”](#).

Programmers who are unfamiliar with CCES or VisualDSP++ should refer to the online help and user’s manuals.

Manual Contents

The manual consists of:

- Chapter 1, [“EZ-Extender Interfaces”](#) on page 1-1
Provides basic board information.
- Chapter 2, [“EZ-Extender Hardware Reference”](#) on page 2-1
Provides information on the hardware aspects of the board.
- Appendix A, [“EZ-Extender Bill Of Materials”](#) on page A-1
Provides a list of components used to manufacture the Blackfin EZ-Extender board.
- Appendix B, [“EZ-Extender Schematic”](#) on page B-1
Provides the resources to allow extender board-level debugging or to use as a reference design. Appendix B is part of the online help.

What’s New in This Manual

This is revision 4.1 of the *Blackfin EZ-Extender Manual*. The manual has been updated to include CCES information. In addition, modifications and corrections based on errata reports against the previous manual revision have been made.

For the latest version of this manual, please refer to the Analog Devices Web site.

Technical Support

You can reach Analog Devices processors and DSP technical support in the following ways:

- Post your questions in the processors and DSP support community at EngineerZone®:
<http://ez.analog.com/community/dsp>
- Submit your questions to technical support directly at:
<http://www.analog.com/support>
- E-mail your questions about processors, DSPs, and tools development software from **CrossCore Embedded Studio** or **VisualDSP++**:

Choose **Help > Email Support**. This creates an e-mail to processor.tools.support@analog.com and automatically attaches your **CrossCore Embedded Studio** or **VisualDSP++** version information and `license.dat` file.

- E-mail your questions about processors and processor applications to:
processor.support@analog.com or
processor.china@analog.com (Greater China support)
- In the **USA only**, call **1-800-ANALOGD** (1-800-262-5643)
- Contact your Analog Devices sales office or authorized distributor. Locate one at:
www.analog.com/adi-sales

Supported Products

- Send questions by mail to:
Processors and DSP Technical Support
Analog Devices, Inc.
Three Technology Way
P.O. Box 9106
Norwood, MA 02062-9106
USA

Supported Products

The Blackfin EZ-Extender is an extender board to the ADSP-BF533 and ADSP-BF561 EZ-KIT Lite evaluation systems.

Product Information

Product information can be obtained from the Analog Devices Web site and the online help.

Analog Devices Web Site

The Analog Devices Web site, www.analog.com, provides information about a broad range of products—analogue integrated circuits, amplifiers, converters, and digital signal processors.

To access a complete technical library for each processor family, go to http://www.analog.com/processors/technical_library. The manuals selection opens a list of current manuals related to the product as well as a link to the previous revisions of the manuals. When locating your manual title, note a possible errata check mark next to the title that leads to the current correction report against the manual.

Also note, [MyAnalog](#) is a free feature of the Analog Devices Web site that allows customization of a Web page to display only the latest information

about products you are interested in. You can choose to receive weekly e-mail notifications containing updates to the Web pages that meet your interests, including documentation errata against all manuals. [MyAnalog](#) provides access to books, application notes, data sheets, code examples, and more.

Visit [MyAnalog](#) to sign up. If you are a registered user, just log on. Your user name is your e-mail address.

EngineerZone

EngineerZone is a technical support forum from Analog Devices. It allows you direct access to ADI technical support engineers. You can search FAQs and technical information to get quick answers to your embedded processing and DSP design questions.

Use EngineerZone to connect with other DSP developers who face similar design challenges. You can also use this open forum to share knowledge and collaborate with the ADI support team and your peers. Visit <http://ez.analog.com> to sign up.

Related Documents

For additional information about the product, refer to the following publications.

Table 1. Related Processor Publications

Title	Description
<ul style="list-style-type: none">• <i>ADSP-BF531/ADSP-BF532/ADSP-BF533 Blackfin Embedded Processor Data Sheet</i>• <i>ADSP-BF561 Blackfin Embedded Symmetric Multiprocessor Data Sheet</i>	General functional description, pinout, and timing of the processor
<ul style="list-style-type: none">• <i>ADSP-BF533 Blackfin Processor Hardware Reference</i>• <i>ADSP-BF561 Blackfin Processor Hardware Reference</i>	Description of the internal processor architecture and all register functions
<i>Blackfin Processor Programming Reference</i>	Description of all allowed processor assembly instructions



If you plan to use the EZ-KIT Lite board in conjunction with a JTAG emulator, also refer to the documentation that accompanies the emulator.

1 EZ-EXTENDER INTERFACES

The Blackfin EZ-Extender board offers the following interfaces.

- [“ADC and Mixed-Signal HSC Interface” on page 1-1](#)
- [“DAC HSC Interface” on page 1-2](#)
- [“Camera Interface” on page 1-3](#)
- [“LCD Interface” on page 1-4](#)

The following sections describe each extender interface.

ADC and Mixed-Signal HSC Interface

The Blackfin EZ-Extender can connect to an analog-to-digital converter (ADCs) and a mixed-signal HSC evaluation board via the ADC/mixed-signal HSC interface. The ADC/mixed-signal HSC interface consists of a 40-pin female header, which contains all of the control and data signals necessary to transfer data between the processor’s parallel peripheral interface (PPI) and the HSC evaluation board. Additionally, the extender provides a RJ-45 connector, which contains all of the serial peripheral interconnect (SPI) signals necessary to configure the control registers of capable HSC converters. For a block diagram of this interface, see [Figure 2-1 on page 2-2](#).

Before using the Blackfin EZ-Extender, familiarize yourself with the documentation and schematics of the target board and the EZ-KIT Lite. For example, on the EZ-KIT Lite, it may be necessary to disable other devices on the PPI, route the PPI clocks, and disable the push buttons.

DAC HSC Interface

To configure the Blackfin EZ-Extender to connect to an ADC or mixed-signal HSC evaluation board, first determine the source of the PPI clock. To learn about possible clock settings, refer to “[Clock Routing Switch \(SW2\)](#)” on page 2-5. It is also necessary to determine the direction of the data and frame synchronization signals. The direction is dependent upon the type of the board to which you connect. With ADC boards, it is necessary to set up the data driver on the extender as a receiver. With mixed-signal boards, the data direction can change and a programmable flag is used to change the direction in real time. The frame sync signals are dependent on the external user interface; thus, the functionality of the interface must be taken into consideration. For more information, refer to “[System Architecture](#)” on page 2-1 and “[DIP Switches and Jumpers](#)” on page 2-4.

Refer to the Analog Devices Web site at www.analog.com/EX1-Extender for more information about the daughter card. To learn more about Analog Devices data converters, go to www.analog.com.

DAC HSC Interface

The Blackfin EZ-Extender can connect to digital-to-analog converter HSC evaluation boards via the DAC HSC interface. The DAC HSC interface consists of a 40-pin male header, which contains all of the control and data signals necessary to transfer data from the processor’s PPI to the DAC evaluation board. Your extender kit includes the cable used to make a connection. For more information about this interface, see [Figure 2-1](#) on page 2-2.

Before using the Blackfin EZ-Extender, familiarize yourself with the documentation and schematics of the target board and the EZ-KIT Lite. For example, on the EZ-KIT Lite, it may be necessary to disable other devices on the PPI, route the PPI clocks, and disable the push buttons.

To configure the Blackfin EZ-Extender to connect to a DAC evaluation board, first determine the source of the PPI clock. To learn about possible

clock settings, refer to “[Clock Routing Switch \(SW2\)](#)” on page 2-5. It is also necessary to determine the direction and source of the data and frame synchronization signals. If your processor holds more than one PPI, the DAC interface allows you to communicate with either PPI0 or PPI1 of the processor. The direction of the frame sync signals is dependent on the target; thus, the functionality of the interface must be taken into consideration. For more information, refer to “[System Architecture](#)” on page 2-1 and “[DIP Switches and Jumpers](#)” on page 2-4.

Example programs can be found in the software installation directory. To learn more about Analog Devices data converters, go to www.analog.com.

Camera Interface

The Blackfin EZ-Extender camera interface is a right-angle 32-pin connector with control signals compatible to the ITU-R BT.656 camera interface specification. Specifically, the extender’s camera interface is directly compatible with camera interface boards, such as the Omnivision OV6630AA evaluation module (this part is no longer available). To learn more about the OV6630AA evaluation module, go to <http://www.ovt.com>. For a block diagram of the camera interface, see [Figure 2-1 on page 2-2](#).

Before using the Blackfin EZ-Extender, familiarize yourself with the documentation and schematics of the target board and the EZ-KIT Lite. For example, on the EZ-KIT Lite, it may be necessary to disable other devices on the PPI, route the PPI clocks, and disable the push buttons.

To configure the Blackfin EZ-Extender to connect to a camera, first determine the source of the PPI clock. To learn about possible clock settings, refer to “[Clock Routing Switch \(SW2\)](#)” on page 2-5. It is also necessary to set the direction of the data and the frame sync signals. The direction of frame synchronization signals depends on the camera’s configuration.

LCD Interface

The data must be set as an input to the PPI port. For more information, refer to “System Architecture” on page 2-1 and “DIP Switches and Jumpers” on page 2-4.

LCD Interface

The LCD interface is intended to drive an LCD display device. A 32-pin, right-angle FLZ-type connector is provided to connect the data and control lines of commercially available LCD panels. For a block diagram of this interface, see [Figure 2-1 on page 2-2](#).

A timing and functional analysis is required to determine if a specific LCD can connect to the Blackfin EZ-Extender. An example of a display which does connect to the extender is the Sharp LQ058T5DRQ1 display (this display is no longer available).

Please note that the power for the backlight feature of the LCD must be provided by the customer. Information on the backlight inverter module (part number LXM1614-14-11) needed to connect to the LCD panel is available at <http://www.microsemi.com/en/sites/default/files/LXM1614-14-11.pdf>. The part number of the connector on the EZ-Extender is JST32FLZ-SM1-R-TB. The cable connecting the JST part to the data port on the LCD is available from Parlex Corporation (part number 050-32-76B).

Before using the Blackfin EZ-Extender, familiarize yourself with the documentation and schematics of the target board and the EZ-KIT Lite. For example, on the EZ-KIT Lite, it may be necessary to disable other devices on the PPI, route the PPI clocks, and disable the push buttons.

To configure the EZ-Extender to connect to the LCD interface, first determine the source of the PPI clock and the source and direction of the data and frame sync signals. If your target processor holds more than one PPI, the LCD interface allows you to communicate with either PPI0 or

PPI1 of the processor. For more information, refer to “[System Architecture](#)” on page 2-1 and “[DIP Switches and Jumpers](#)” on page 2-4.

Example programs can be found in the installation directory. To learn more about Analog Devices LCD drivers, go to www.analog.com.

LCD Interface

2 EZ-EXTENDER HARDWARE REFERENCE

This chapter describes the hardware design of the Blackfin EZ-Extender. The following topics are covered.

- [“System Architecture” on page 2-1](#)
Describes the configuration of the extender and explains how the board components interface with the processor and EZ-KIT Lite.
- [“DIP Switches and Jumpers” on page 2-4](#)
Describes the function of the configuration DIP switches.

System Architecture

A detailed block diagram of the Blackfin EZ-Extender is shown in [Figure 2-1](#). Note that the arrow in the bidirectional driver symbols denotes the direction of the driver when in transmit mode. The bidirectional driver is in transmit mode when the direction pin is pulled high. Use the diagram in conjunction with information in [“DIP Switches and Jumpers”](#) section of this manual to configure your Blackfin EZ-Extender.

Before using the EZ-Extender, familiarize yourself with the documentation and schematics of the target board and the EZ-KIT Lite. For example, on the EZ-KIT Lite, it may be necessary to disable other devices on the PPI, route the PPI clocks, and disable the push buttons.

The block diagram in [Figure 2-1](#) shows that all of the interfaces have clock signals, frame sync signals, data signals and, possibly, general-purpose signals. Each signal’s configuration depends on how your interface operates.

System Architecture

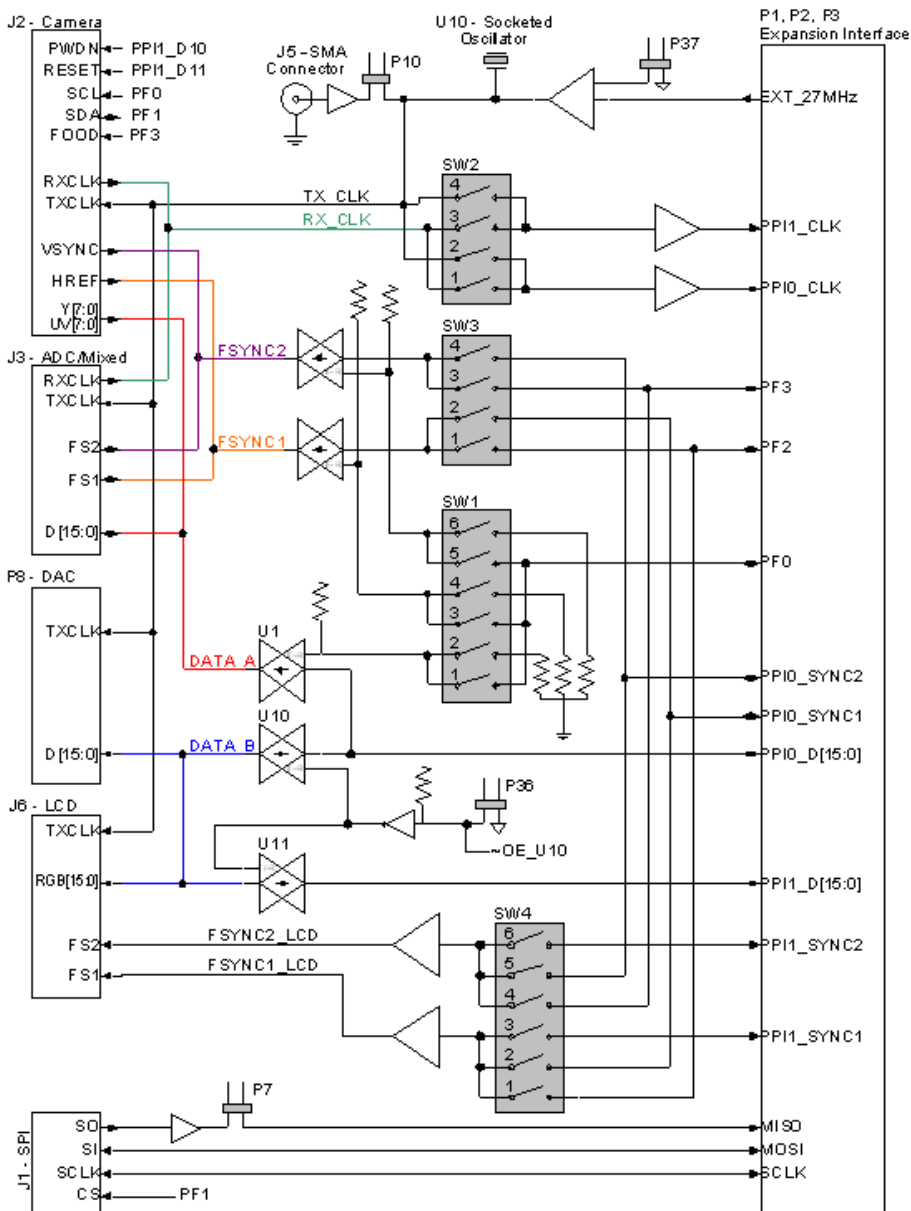

Figure 2-1. Blackfin EZ-Extender Block Diagram

The EZ-Extender holds two clock signals, TX_CLK and RX_CLK. The TX_CLK signal is used as an output to the interface you are using. The TX_CLK signal can be generated in three ways: applying a signal via an SMA connector, populating a socket with an oscillator, or using a 27 MHz signal provided by the EZ-KIT Lite. Only one of these sources can be used at a time, the other sources must be disabled. For how to disable the TX_CLK sources, see [“SMA Connector Clock Disconnect Jumper \(P10\)” on page 2-9](#) and [“External Clock Disable Jumper \(P37\)” on page 2-11](#). The RX_CLK signal is generated by the target board. Both the TX_CLK and RX_CLK can connect to the PPI_CLK signal as an input to the processor. See [“Clock Routing Switch \(SW2\)” on page 2-5](#) for more information.

The ADC/mixed-signal HSC interface and camera interface have two frame sync signals, FSYNC1 and FSYNC2. For information on how to set the direction and the source of these signals, refer to [“Direction Control Switch \(SW1\)” on page 2-4](#) and [“General Frame Sync Routing Switch \(SW3\)” on page 2-7](#).

The LCD interface has two frame sync signals, FSYNC1_LCD and FSYNC2_LCD. These signals are always outputs, but it is possible set the source of the signals. For more information see, [“LCD Frame Sync Routing Switch \(SW4\)” on page 2-8](#).

The ADC/mixed-signal HSC interface and camera interface connect to the DATA_A[15:0] parallel bus. The DAC HSC interface and the LCD interface connect to the DATA_B[15:0] parallel bus. The DATA_A bus is attached to only the PPI0 bus, while DATA_B[15:0] can connect to either PPI0 or PPI1 busses. This allows access to all of the interfaces with a single PPI port or access to two separate interfaces with two PPI ports. For more information about the routing of the PPI data signals see, [“PPI Data Routing Jumper \(P36\)” on page 2-10](#). To configure the direction of the DATA_A signals, see [“Direction Control Switch \(SW1\)” on page 2-4](#).

DIP Switches and Jumpers

The following section describes the function of all of the jumpers and switches on the EZ-Extender. Before connecting the extender, make sure you understand each possible settings effect on your application.

Direction Control Switch (SW1)

The PPI interface is bidirectional and half-duplex. A designated DIP switch, SW1, provides an independent direction control for the DATA_A bus and the sync signals (FSYNC1 and FSYNC2) going to the camera interface and ADC/mixed-signal HSC interface, as illustrated in [Figure 2-1 on page 2-2](#). Each of the signals can be hardwired to be either transmit or receive, or can be changed in real time using the PF0 processor programmable flag pin.

 If the PF0 programmable flag is intended for direction control, ensure the flag is not used for other purposes on the EZ-KIT Lite board (the motherboard).

When the switch connects a direction control signal to ground (GND), the corresponding signal (or signals) being controlled is an input.

The SW1 DIP switch settings are summarized in [Table 2-1](#) through [Table 2-3](#).

Table 2-1. SW1 Data Direction Control Positions 1 and 2

SW1 Position 1	SW1 Position 2	Function
OFF	OFF	EZ-KIT Lite is transmitter
ON	OFF	PF0 sets the direction: 0 = EZ-KIT Lite is receiver 1 = EZ-KIT Lite is transmitter
OFF	ON	EZ-KIT Lite is receiver
ON	ON	Do not use

Table 2-2. SW1 FSYNC1 Direction Control Positions 3 and 4

SW1 Position 3	SW1 Position 4	Function
OFF	OFF	EZ-KIT Lite is transmitter
ON	OFF	PF0 sets the direction: 0 = EZ-KIT Lite is receiver 1 = EZ-KIT Lite is transmitter
OFF	ON	EZ-KIT Lite is receiver
ON	ON	Do not use

Table 2-3. SW1 FSYNC2 Direction Control Positions 5 and 6

SW1 Position 5	SW1 Position 6	Function
OFF	OFF	EZ-KIT Lite is transmitter
ON	OFF	PF0 sets the direction: 0 = EZ-KIT Lite is receiver 1 = EZ-KIT Lite is transmitter
OFF	ON	EZ-KIT Lite is receiver
ON	ON	Do not use

Clock Routing Switch (SW2)

The source of the clock input signals PPI0_CLK and PPI1_CLK are configured through the SW2 DIP switch settings, as illustrated in [Figure 2-1](#) on [page 2-2](#). The SW2 settings are summarized in [Table 2-4](#) and [Table 2-5](#).

Table 2-4. PPI0_CLK Source Settings

SW2 Position 1 RX_CLK	SW2 Position 2 TX_CLK	PPI0_CLK Source
OFF	OFF	The PPI0_CLK signal is not generated by the EZ-Extender
OFF	ON	TX_CLK; this signal must be generated by one of the user-configured PPI clock sources