



Chipsmall Limited consists of a professional team with an average of over 10 year of expertise in the distribution of electronic components. Based in Hongkong, we have already established firm and mutual-benefit business relationships with customers from,Europe,America and south Asia,supplying obsolete and hard-to-find components to meet their specific needs.

With the principle of "Quality Parts,Customers Priority,Honest Operation,and Considerate Service",our business mainly focus on the distribution of electronic components. Line cards we deal with include Microchip,ALPS,ROHM,Xilinx,Pulse,ON,Everlight and Freescale. Main products comprise IC,Modules,Potentiometer,IC Socket,Relay,Connector.Our parts cover such applications as commercial,industrial, and automotives areas.

We are looking forward to setting up business relationship with you and hope to provide you with the best service and solution. Let us make a better world for our industry!



## Contact us

Tel: +86-755-8981 8866 Fax: +86-755-8427 6832

Email & Skype: info@chipsmall.com Web: www.chipsmall.com

Address: A1208, Overseas Decoration Building, #122 Zhenhua RD., Futian, Shenzhen, China



# 4G LTE Cellular Band Blade Antenna



AEACCA115021-S698



115.6 x 21.7 x 5.8 mm  
RoHS/RoHS II Compliant

MSL = N/A: NOT APPLICABLE

## FEATURES

- LTE700, GSM850, GSM900, DCS, PCS, UMTS1, LTE2600
- Gain of 2dBi
- VSWR  $\leq$  2.0
- Low profile 5.8mm
- Fakra connector
- Adhesive mount

## APPLICATIONS

- IoT applications
- M2M
- 4G/LTE applications
- GSM
- DCS
- PCS
- UMTS
- Remote technology/ monitoring
- POS terminals

## EXTERNAL ANTENNA

Parameters	Min.	Typ.	Max.	Units	Note
Frequency Range		698~960/1710~2655		MHz	
VSWR			2.0		
Polarization Model	Linear				
Impedance		50		$\Omega$	
Gain		2		dBi	(Zenith)
Operating Temperature	-40		+85	$^{\circ}\text{C}$	
Input Power			10	W	

## RETURN - LOSS CHARACTERISTICS

### S11 Return-Loss

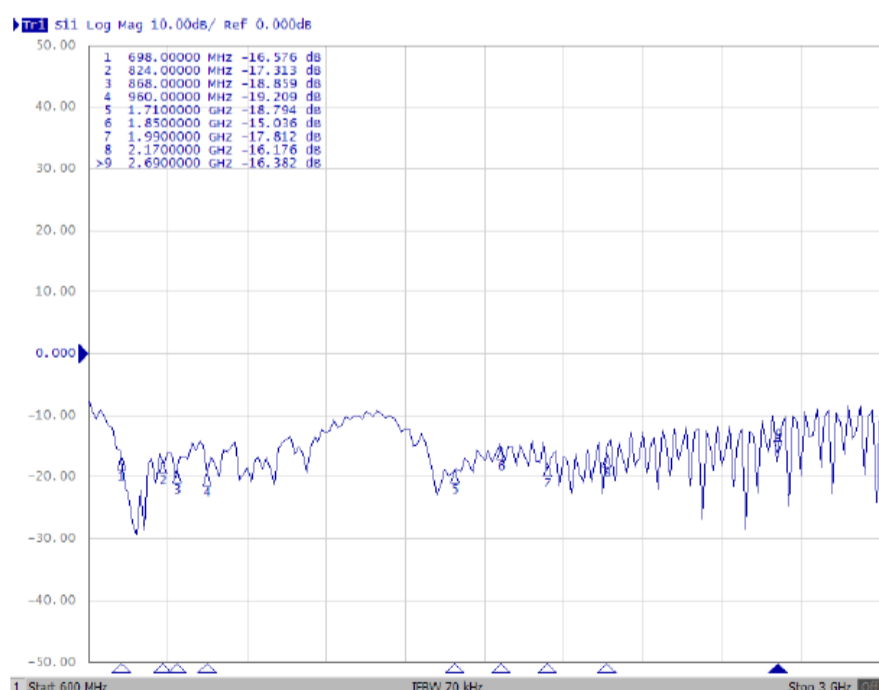

5101 Hidden Creek Ln Spicewood TX 78669  
Phone: 512-371-6159 | Fax: 512-351-8858  
For terms and conditions of sales, please visit:  
[www.abracon.com](http://www.abracon.com)

REVISED: 03.19.2018

ABRACON IS  
ISO9001-2008  
CERTIFIED

# 4G LTE Cellular Band Blade Antenna



AEACCA115021-S698



115.6 x 21.7 x 5.8 mm  
RoHS/RoHS II Compliant

MSL = N/A: NOT APPLICABLE

## RADIATION PATTERNS

### XY Plane

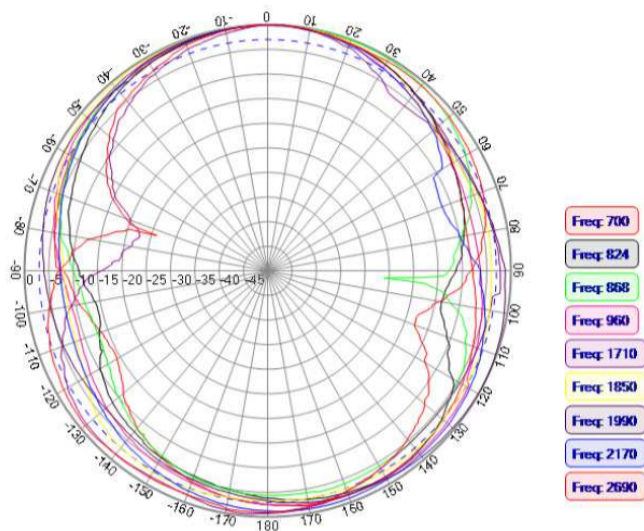

### XZ Plane

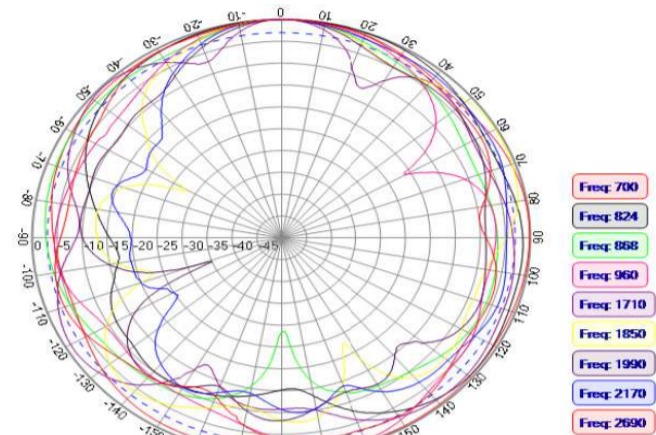

### YZ Plane

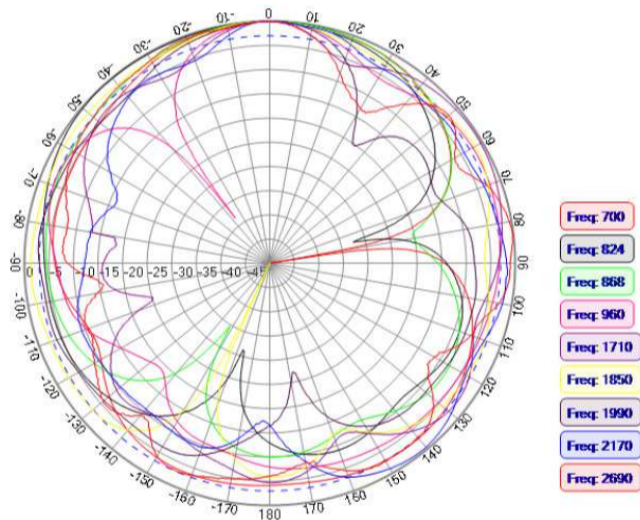

### 700 MHz

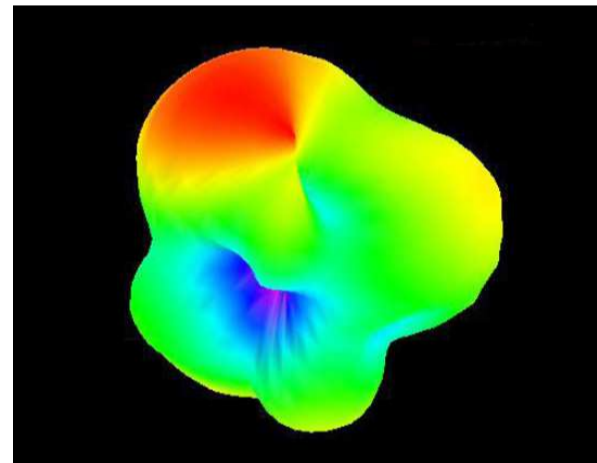

### 824 MHz

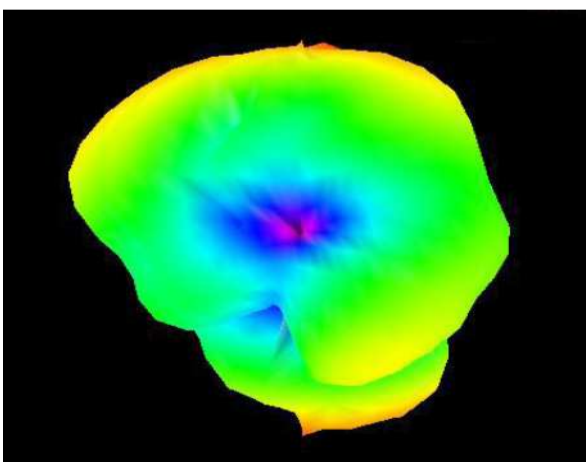

### 868 MHz

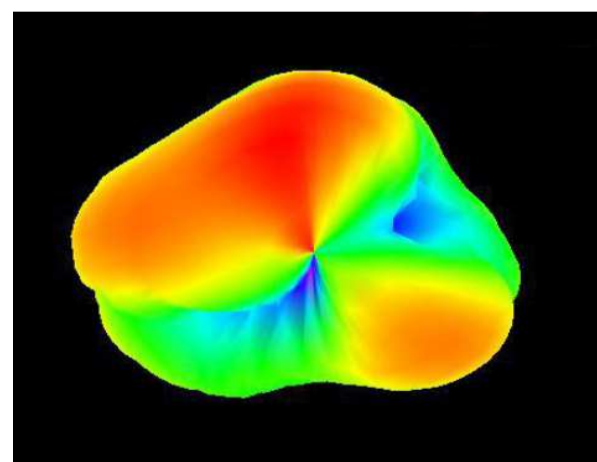

# 4G LTE Cellular Band Blade Antenna



AEACCA115021-S698



115.6 x 21.7 x 5.8 mm  
RoHS/RoHS II Compliant

MSL = N/A: NOT APPLICABLE

## 3D PATTERNS

960 MHz

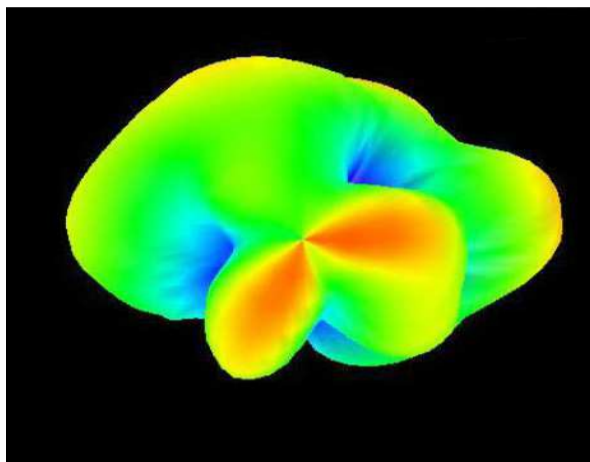

1710 MHz

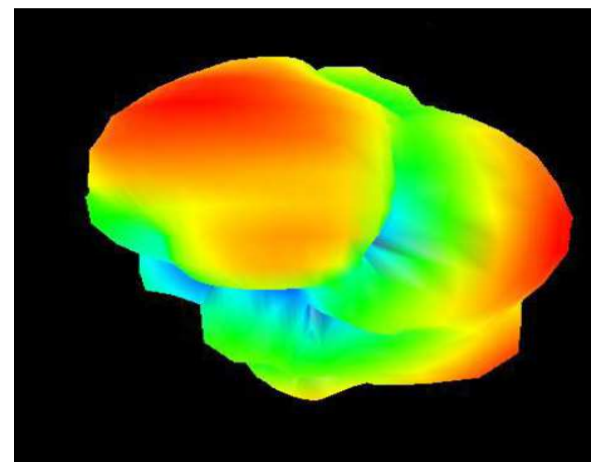

1850 MHz

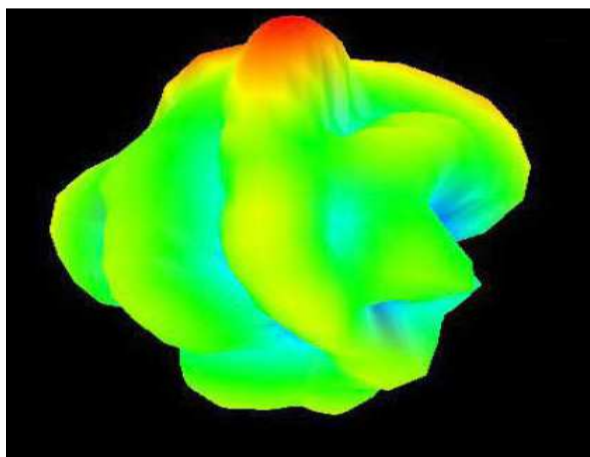

1990 MHz

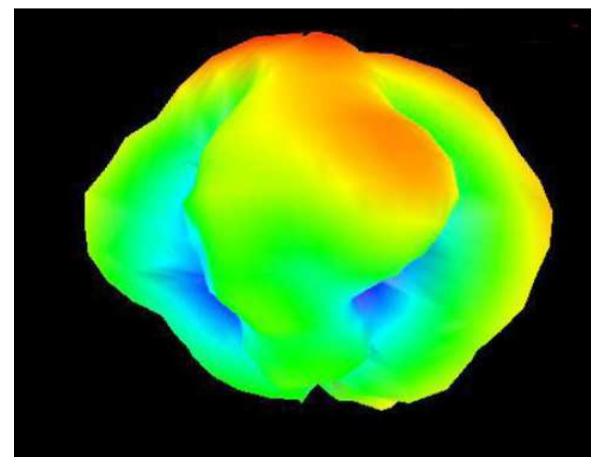

2170 MHz

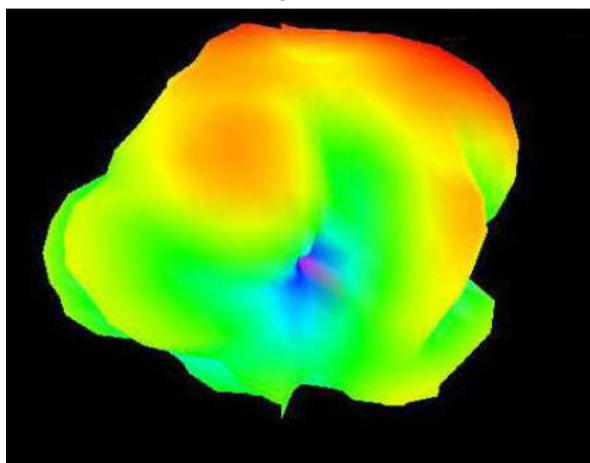

2690 MHz

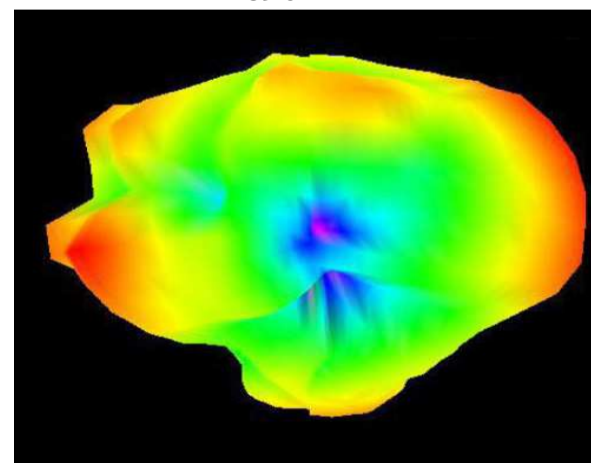

Frequency (MHz)	700	824	868	960	1710	1850	1990	2170	2690
Peak Gain (dBi)	2.12	0.83	2.60	1.00	1.61	0.78	0.34	-0.89	-3.00
Efficiency (%)	59	53	56	71	57	58	57	56	55



5101 Hidden Creek Ln Spicewood TX 78669  
Phone: 512-371-6159 | Fax: 512-351-8858  
For terms and conditions of sales, please visit:  
[www.abracon.com](http://www.abracon.com)

REVISED: 03.19.2018

ABRACON IS  
ISO9001-2008  
CERTIFIED

# 4G LTE Cellular Band Blade Antenna



AEACCA115021-S698



115.6 x 21.7 x 5.8 mm  
RoHS/RoHS II Compliant

MSL = N/A: NOT APPLICABLE

## DIMENSIONS

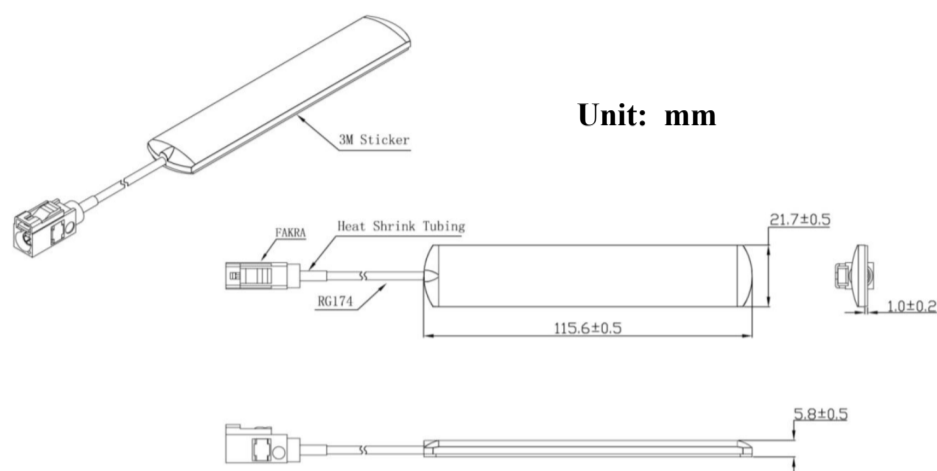

Parameters	Description
Cable Length	3.00 m
RF Cable	RG174
RF Connector	FAKRA/SMA or other
Radome Material	ABS
Mounting Type	Adhesive

## PACKAGING

Each 700 x 320 x 155 mm size carton includes 250 pcs antenna, 13kgs/carton.

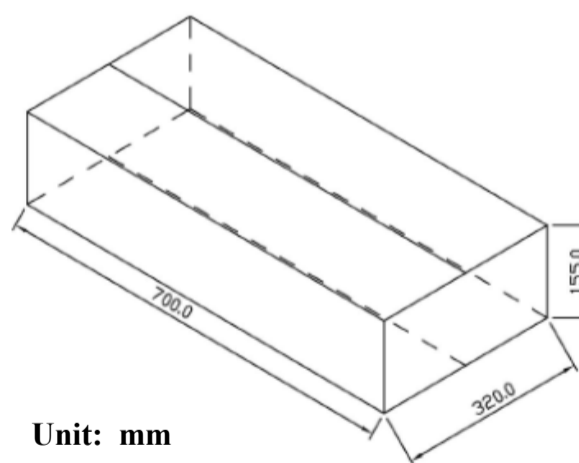
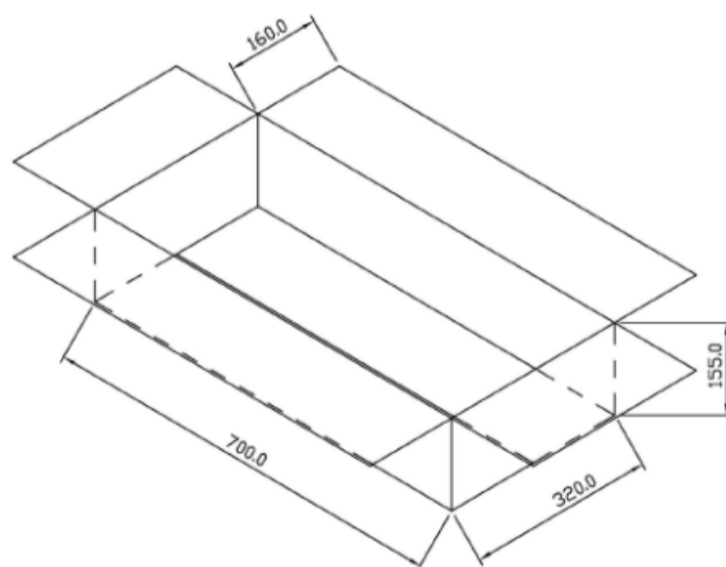

Unit: mm



5101 Hidden Creek Ln Spicewood TX 78669  
Phone: 512-371-6159 | Fax: 512-351-8858  
For terms and conditions of sales, please visit:  
[www.abracon.com](http://www.abracon.com)

REVISED: 03.19.2018

ABRACON IS  
ISO9001-2008  
CERTIFIED