



Chipsmall Limited consists of a professional team with an average of over 10 year of expertise in the distribution of electronic components. Based in Hongkong, we have already established firm and mutual-benefit business relationships with customers from,Europe,America and south Asia,supplying obsolete and hard-to-find components to meet their specific needs.

With the principle of “Quality Parts,Customers Priority,Honest Operation,and Considerate Service”,our business mainly focus on the distribution of electronic components. Line cards we deal with include Microchip,ALPS,ROHM,Xilinx,Pulse,ON,Everlight and Freescale. Main products comprise IC,Modules,Potentiometer,IC Socket,Relay,Connector.Our parts cover such applications as commercial,industrial, and automotives areas.

We are looking forward to setting up business relationship with you and hope to provide you with the best service and solution. Let us make a better world for our industry!



Contact us

Tel: +86-755-8981 8866 Fax: +86-755-8427 6832

Email & Skype: info@chipsmall.com Web: www.chipsmall.com

Address: A1208, Overseas Decoration Building, #122 Zhenhua RD., Futian, Shenzhen, China



10-Bit to 16-Bit Programmable Angular Magnetic Encoder

Application Note

Description

AEAT-8800-Q24 is a CMOS magnetic sensor structure suitable for contactless 360° encoding based on the Hall Effect. It provides an angle output up to 16 bits of resolution and simultaneous incremental output of up to 4096 CPR. An integrated Hall structure at the core of the device uses a single 2-pole disc magnet to convert the magnetic field vector in the chip plane into an AC signal whose amplitude and phase correspond to the magnitude and direction of the field.

An internal digital signal processing unit then processes and conditions the raw AC signal from the sensor. The output signals are available in three different forms:

- Pulse Width Modulation (PWM)
- 16-bit absolute position through the Serial Synchronous Interface (SSI)
- Incremental output (ABI and UVW signals)

These features can be programmed by configuring the internal registers in program mode.

More information about the product specifications of AEAT-8800-Q24 are available in the product data sheet.

Operation Mode

The AEAT-8800-Q24 features two types of operational modes that are normal operation mode, one-time programming (OTP) mode.

Normal Operation Mode

The Normal mode is the normal operating mode of the chip. The absolute output (10-bit, 12-bit, 14-bit, or 16-bit absolute position data) is available through SSI pins (DO, CLK, and NCS). The following are the output signal conditions during AEAT-8800-Q24 initialization:

- PWM signals all 0s.
- ABI signals all 1s.
- UVW signals all 0s.

The incremental positions are indicated on ABI and UVW signals with user-configurable CPR 32, 64, 128, 256, 512, 1024, 2048, 4096 of ABI signals and pole pairs from 1 to 8 (2 to 16 poles) for UVW commutation signals.

Figure 2 shows the recommended circuit diagram for AEAT-8800-Q24.

OTP Programming Mode

AEAT-8800-Q24 is an OTP ASIC. OTP registers are 0 by default.

During OTP programming, the VDD voltage is recommended to be at the minimum of 5.5V, typical 5.6V, and maximum of 5.7V.

Programming of AEAT-8800-Q24 can be performed with the HEDS-8988 programming kit or any tester/programmer device using the guidelines provided.

Figure 2 shows the recommended circuit diagram for AEAT-8800-Q24.

Absolute and Incremental Programming

The absolute resolution can be set to 10, 12, 14 or 16 bits. For incremental selection, ABI or UVW can be selected by following the instructions in the following sections. The PWM output is available as well.

The OTP shadow registers are programmable using the SPI protocol. Writing specific commands to specific addresses of the internal registers will program values of OTP shadow registers to OTP permanently.

Memory Map

The Broadcom AEAT-8800-Q24 uses nonvolatile OTP as shown in the tables that follow.

The memory is separated into 8 bits per address. During OTP programming, the VDD voltage is recommended for a minimum of 5.5V, typical 5.6V, and maximum of 5.7V.

Nonvolatile Register (OTP)

1. OTP is one-time programmable only. Any OTP bit with value 0 can be written to 1, but *not* vice versa. Do *not* program 1 to the same address bit twice.
2. OTP shadow registers are volatile registers that are loaded with corresponding OTP values after power on.
3. All bits (except addresses 0x00–0x03, and 0x10–0x12) are in LOCK mode by default after power on. To enter UNLOCK mode (to be able to write to the OTP shadow registers or registers), write 0xAB to address 0x10.

4. In UNLOCK mode, you may write to *any* OTP shadow registers or registers. Values written will remain until power off.
5. The UNLOCK state is maintained until the power supply is turned off or any value (except 0xAB) is written to address 0x10.
6. All OTP memory is programmable by writing only the appropriate commands to addresses 0x11–0x13 and 0x1B (see [Programming Customer Reserved OTP](#) and [Programming User Configuration OTP](#)).

OTP Shadow Registers

1. OTP shadow registers are volatile (upon power up, reload values from OTP) and are not written to OTP automatically.
2. To write OTP shadow registers values to OTP (nonvolatile) memory, see [Programming Customer Reserved OTP](#) and [Programming User Configuration OTP](#).
3. The OTP shadow registers will be from address 0x00 to 0x0D.

The tables that follow show the registers.

Customer Reserve and Zero Reset Registers

Address	Bit(s)	Name	Description	Default
0x00	[7:0]	Customer Reserve 0	User programmable	8'h0
0x01	[7:0]	Customer Reserve 1	User programmable	8'h0
0x02	[7:0]	Zero Reset0	Zero Reset Position [7:0]	8'h0
0x03	[7:0]	Zero Reset1	Zero Reset Position [15:8]	8'h0

Customer Configuration Registers

These registers are required to be unlocked, which is done by writing 8'hAB to address 0x10, then writing to the OTP shadow register.

Table 1 Customer Configuration 0 Registers

Address	Bit(s)	Name	Description	Default
0x04	[7]	UVW Select	1: Select UVW mode 0: Select PWM mode	0
	[6:5]	PWM Setting	11: PWM period = 8193 μ s 10: PWM period = 4097 μ s 01: PWM period = 2049 μ s 00: PWM period = 1025 μ s	00
	[4:3]	I-width Setting	11: (ABI) I-width = 360 electrical deg (edeg) 10: (ABI) I-width = 270 electrical deg (edeg) 01: (ABI) I-width = 180 electrical deg (edeg) 00: (ABI) I-width = 90 electrical deg (edeg)	00
	[2:0]	UVW Setting	111: UVW = 8 pole-pairs 110: UVW = 7 pole-pairs 101: UVW = 6 pole-pairs 100: UVW = 5 pole-pairs 011: UVW = 4 pole-pairs 010: UVW = 3 pole-pairs 001: UVW = 2 pole-pairs 000: UVW = 1 pole-pairs	000

Table 2 Customer Configuration 1 Registers

Address	Bit(s)	Name	Description	Default
0x05	[7:4]	CPR Setting 1 ^a	0111: (ABI) 4096 CPR 0110: (ABI) 2048 CPR 0101: (ABI) 1024 CPR 0100: (ABI) 512 CPR 0011: (ABI) 256 CPR 0010: (ABI) 128 CPR 0001: (ABI) 64 CPR 0000: (ABI) 32 CPR	0000
	[3:0]	Hysteresis Setting	1001: 1.4 mechanical degree (mdeg) 1000: 0.7 mechanical degree (mdeg) 0111: 0.35 mechanical degree (mdeg) 0110: 0.17 mechanical degree (mdeg) 0101: 0.08 mechanical degree (mdeg) 0100: 0.04 mechanical degree (mdeg) 011: 0.02 mechanical degree (mdeg) 0010: 0.01 mechanical degree (mdeg) 0001: 0.005 mechanical degree (mdeg) 0000: No Hysteresis	0000

- a. Incremental: The CPR setting 1 in address 0x05 must match to CPR setting 2 in 0x06.
Absolute: For absolute only application, set CPR setting 2 in 0x06 to 0100.

Table 3 Customer Configuration 2 Registers (Read the Important Notes Highlighted in the Table)

Address	Bit(s)	Name (Note)	Description	Default
0x06	[7]	Dir ^a	1: Count up at counterclockwise rotation 0: Count up at clockwise rotation	0
	[6]	Zero Latency Mode ^b	1: Zero latency is on 0: Zero latency is off	0
	[5:4]	Absolute Resolution	00: 16-b absolute resolution (SSI) 01: 14-b absolute resolution (SSI) 10: 12-b absolute resolution (SSI) 11: 10-b absolute resolution (SSI)	00
	[3:0]	CPR Setting 2 ^c	0110: 4096 CPR 0110: 2048 CPR 0100: 1024 CPR 0100: 512 CPR 0011: 256 CPR 0010: 128 CPR 0010: 64 CPR 0010: 32C PR 0100: Absolute resolution	0000
0x0a	[1]	Operating Voltage ^d	0: 3.3V 1: 5.0V	0

- See [Figure 1](#) for the direction definition.
- Zero latency is only applicable from 32 CPR ~1024 CPR. When Zero Latency mode is on, you must set CPR setting 2 in 0x06 to 0101 for all the applicable CPRs (32~1024).
- Incremental: The CPR setting 1 in address 0x05 must match to CPR setting 2 in 0x06.
Absolute: For absolute only application, set CPR setting 2 in 0x06 to 0100.
- IMPORTANT:** If the user wants to change the operating voltage to 5.0V, the following steps **must** be performed before proceeding to customer configuration from address 0x00 to 0x06.
 - Write 0xAB to address 0x10 to unlock the register.
 - Write 0x00 to Reg 0x07, 0x08, and 0x09.
 - Write 0x02 to address 0x0a.
 - Change the voltage at VDDA pin to 5.6V ± 0.1V for OTP programming.
 - Write 0xA4 to address 0x14 to OTP the operating voltage.
 - Power cycle (power off and power on) the IC.

Programming Customer Reserved OTP

Perform the following steps to program Customer Reserved OTP shadow registers to OTP.

- Write the desired values to the Customer Reserved OTP shadow registers (0x00–0x01).
- Read back the Customer Reserved OTP shadow registers (0x00–0x01) to confirm that the correct values are stored.
- Write 8'hA1 to address 0x11 to program the Customer Reserved OTP shadow registers (0x00–0x01) to OTP.
- Perform a power supply cycle and read back the Customer Reserved OTP shadow registers (0x00–0x01) to confirm correct values are stored into OTP.

Programming User Configuration OTP

Perform the following steps to program User Configuration OTP shadow registers to OTP.

1. Write the desired values to the User Configuration OTP shadow registers (0x04–0x06).
2. Read back the User Configuration OTP shadow registers (0x04–0x06) to confirm correct values are stored.
3. Write 8'hA3 to address 0x13 to program the User Configuration OTP shadow registers (0x04–0x06) to OTP.
4. Perform a power supply cycle (power off and power on) and read back the User Configuration OTP shadow registers (0x04–0x06) to confirm that the correct values are stored into OTP.

Zero Reset and Static Offset Calibration

Zero Reset Programming

AEAT-8800-Q24 allows users to configure a zero reset position. This value is stored at OTP 0x02 (lower 8-b) and 0x03 (upper 8-b). To set to the zero reset position, for example, position X, use a procedure similar to the following.

NOTE You should decide the desired direction or orientation (as outlined in [Direction](#)) before setting the zero reset position.

1. Stop the motor at position X.
2. Read the 16-b value of position X using the SSI protocol (for example, read 16'hABCD).
3. Write the lower 8-b (from the preceding example, 8'hCD) to the OTP shadow registers 0x02 using SPI.
4. Write the upper 8-b (from the preceding example, 8'hAB) to the OTP shadow registers 0x03 using SPI.
5. Confirm that the correct zero reset value is written to the OTP shadow registers by rereading the motor position value using SSI. Make sure that the current position read is 16'h0000 (excluding step jumps incurred by noise).
6. To permanently save this zero reset value, write 8'hA2 to internal registers 0x12.
7. Power-cycle (power off and power on) the chip.
8. Confirm that the correct zero reset value is written to OTP by rereading the motor position value using SSI. Make sure that the current position read is 16'h0000 (excluding the step jumps incurred by noise).

Direction

The direction must be defined whether to count-up at clockwise or counterclockwise per rotation. Per the default setting, if the magnet is spinning at a clockwise position, based on the user's line of sight as shown in [Figure 1](#), AEAT 8800 counts up.

Figure 1 Direction Definition when Magnet Rotates

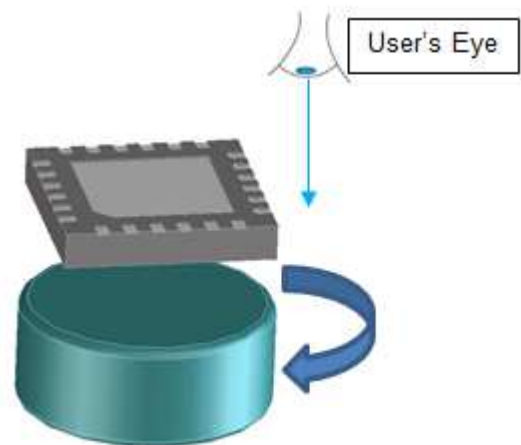

Offset Calibration (for Optimum Performance)

The AEAT-8800-Q24 features offset calibration to enhance the angular accuracy measurement detected by the Hall sensors. This feature allows you to align the Hall sensors to the best accuracy within the recommended alignment area as defined in [Magnet and IC Package Placement](#).

This alignment addresses the variations of the spatial displacement during integration.

Perform the following steps to use this feature.

1. Write 8'h02 to 0x17, bit 1, to start a calibration.
2. Rotate the magnet any direction at 100 rpm.
3. Monitor the ABI and UVW output of AEAT-8800-Q24 with an oscilloscope.
4. The following signals (monitor from an oscilloscope) describe the status of the signal during calibration:
 - ABI = 3'b111: Indication of AEAT-8800-Q24 successfully calibrated.
 - A=0: Indication that the distance between AEAT-8800-Q24 and the magnet is too close or too far.
 - B or/and I=0: Indication of AEAT-8800-Q24 is not able to calibrate correctly due to poor magnet alignment; it is beyond of its spatial tolerance.
5. Repeat step 2 to step 3 until indication at step 4 meets the expected criterion.
6. To end the calibration, write 8'h00 to 0x17.
7. The calibration is completed when the ABI signal is all high (observed from the oscilloscope).
8. To OTP offset calibration, write 8'hA5 to address 0x1B.

NOTE A typical successful calibration should be completed in less than 30 revolutions.

Safety Alarm

AEAT-8800-Q24 provides following safety alarms:

- Magnet High (MHI) error: This error indicates the magnet strength detected by chip is too strong. When this is flagged high consistently, change to a weaker magnet, or increase the distance between the chip and the magnet.
- Magnet Low (MLO) error: This error indicates the magnet strength detected by chip is too weak. When this is flagged high consistently, change to a stronger magnet, or decrease the distance between the chip and the magnet.

These alarms are read out from SSI interface as described in the "Absolute Output Format" section in the data sheet.

AEAT-8800-Q24 Circuit Diagram

Figure 2 Recommended Circuit Diagram for AEAT-8800-Q24 during Normal Operation and OTP Programming

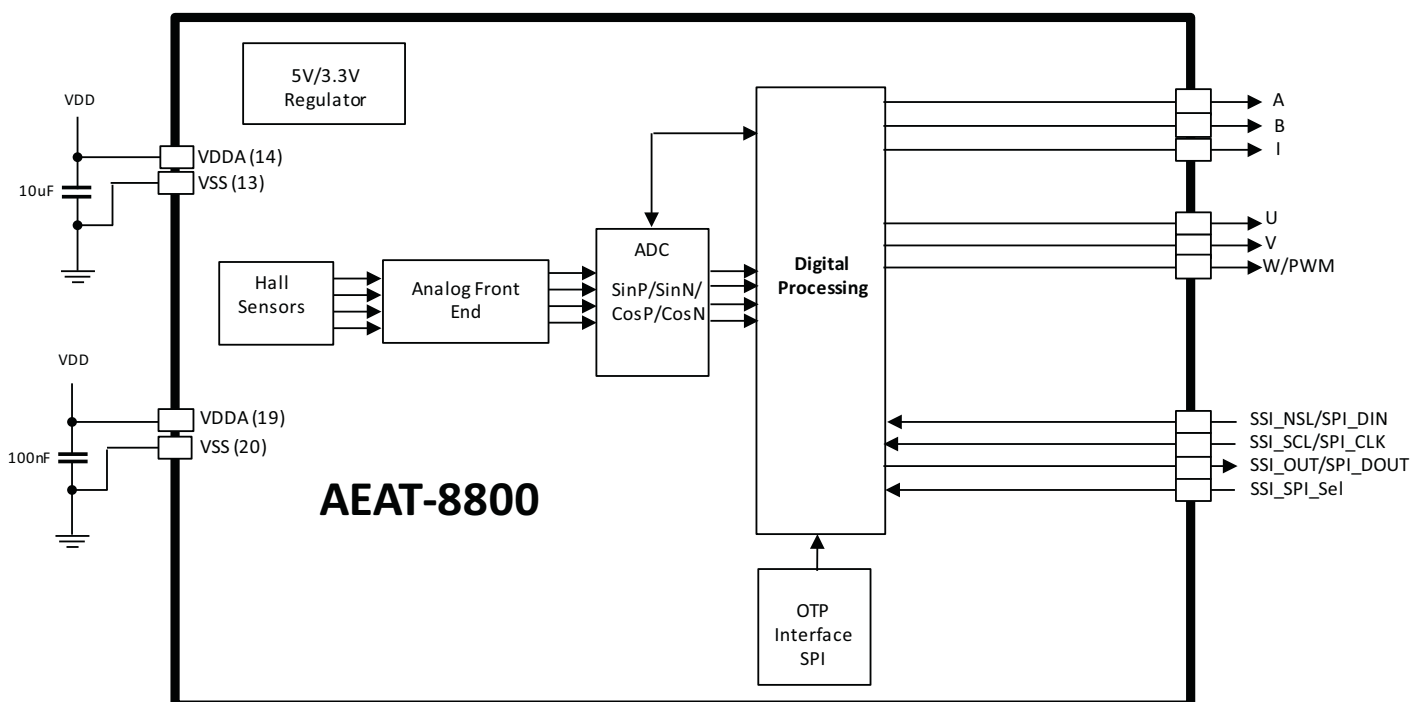

NOTE

- Refer to the "Programming the AEAT-8800-Q24" section in the data sheet for OTP programming.
- Connect the 10 μ F and 100 nF capacitors as close to the individually assigned power and ground pins as possible.

Recommended Magnetic Input Specifications

	Parameter	Symbol	Min.	Typ.	Max.	Units	Units
1.	Diameter	d	—	6	—	mm	Recommended magnet: Cylindrical magnet, diametrically magnetized and 1 pole pair.
2.	Thickness	t	—	2.5	—	mm	
3.	Magnetic input filed magnitude	Bpk	45	—	75	mT	Required vertical component of the magnetic field strength on the die's surface, measured along a concentric circle.
4.	Magnet displacement radius	R _m	—	—	0.5	mm	Displacement between the magnet axis to the device center.
5.	Recommended magnet material and temperature drift		—	-0.12	—	%/K	NdFeB (Neodymium Iron Boron), grade N35SH. For better performance, consider an SmCo (Samarium Cobalt) magnet.

Diametrically Magnetized Magnet

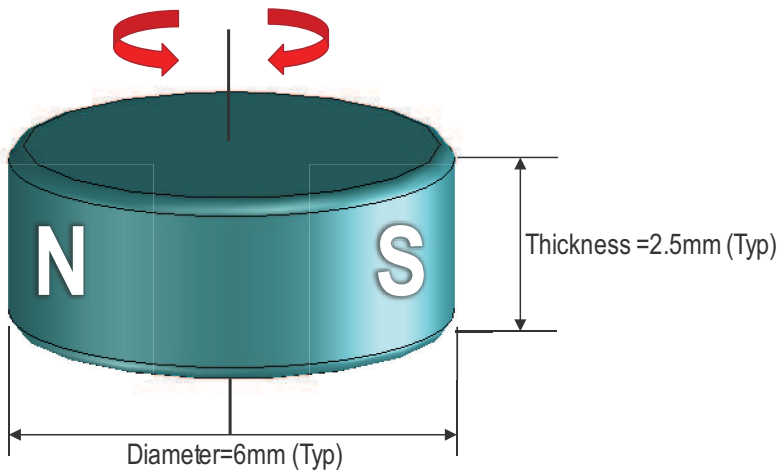

Magnet and IC Package Placement

Figure 3 Defined Chip Sensor Center and Magnet Displacement Radius

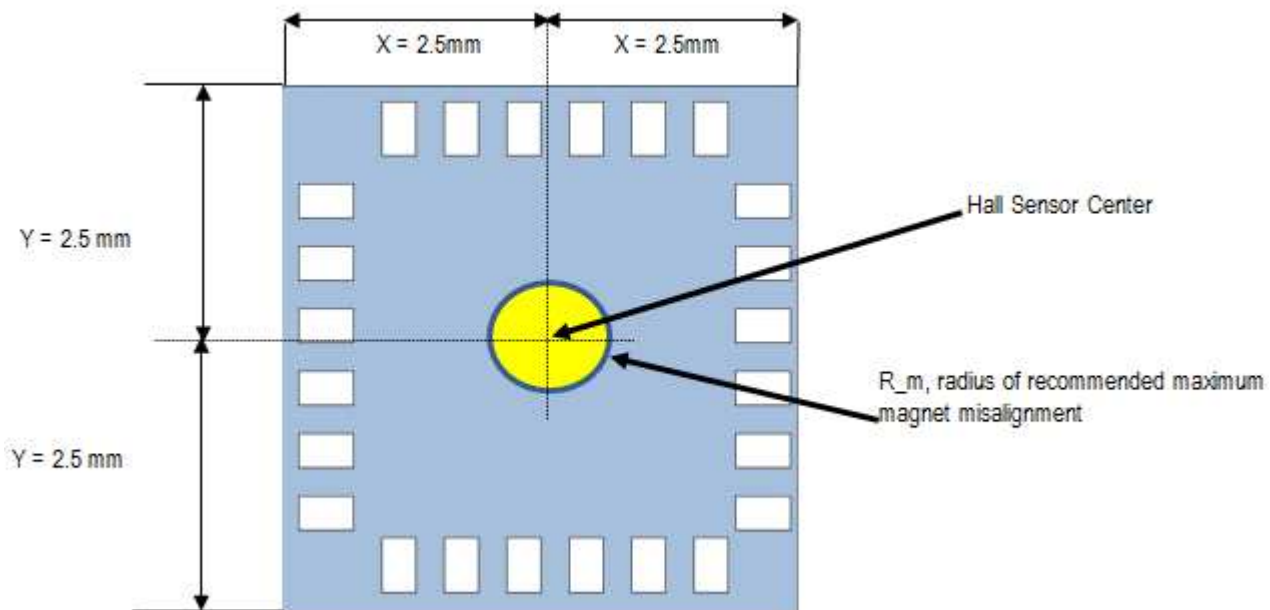

The magnet's center axis should be aligned within a displacement radius of 0.5 mm from defined hall sensor center.

The magnet should be put facing the sensor. The Z gap varies depending on the magnetic strength on the die surface, with recommended magnet material and dimension.

The typical distance Z is 0.5 mm to 1.5 mm. However, larger distances are possible as long as the magnetic strength is within the defined limit. It is important not to put magnetic material close to the magnet as it will affect the magnetic field and increase the INL. The magnetic material must keep from the IC package a minimum of 30 mm. The magnet must be mount on nonmagnetic part.

Figure 4 Vertical Placement of the Magnet

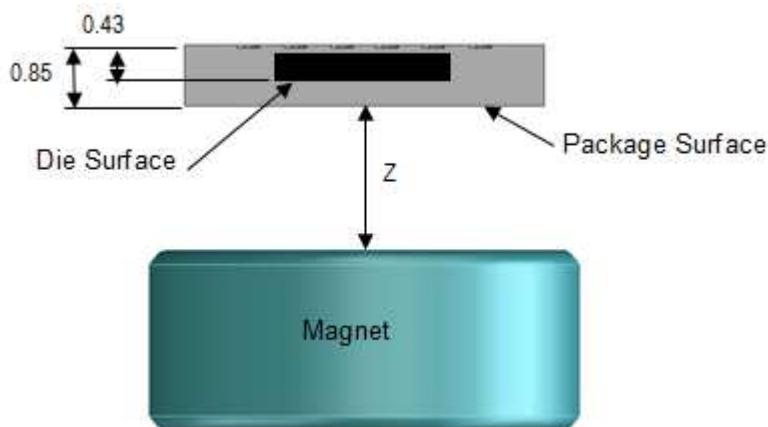

AEAT-8800-Q24 Pins Assignment and Description

Figure 5 AEAT-8800-Q24: Pins Assignment and Description

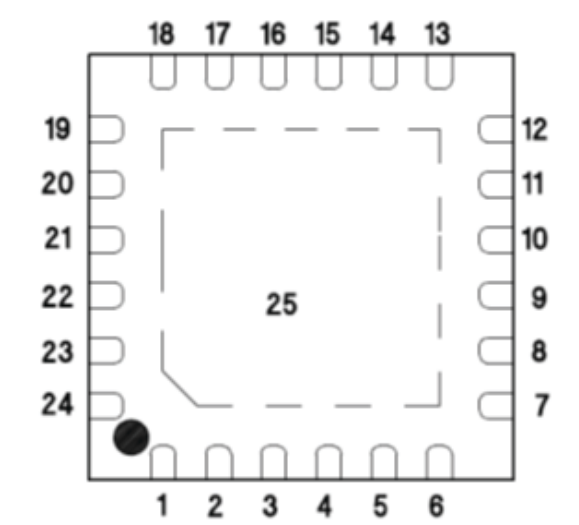

Table 4 Pin Assignment

Pin	Symbol	Description
1-6	NC	No Connection
7	I	Index output (ABI mode)
8	B	Incremental B output (ABI mode)
9	A	Incremental A output (ABI mode)
10	SSI_SCL_SPI_CLK	SSI/SPI clock input
11	SSI_NSL_SPI_DI	SSI/SPI data input
12	SSI_DO_SPI_DO	SSI/SPI data out
13	VSS	Supply Ground
14	VDDA	3.3V/5V Supply input
15	NC	No Connection
16	NC	No Connection
17	NC	No Connection
18	NC	No Connection
19	VDDA	3.3V/5V Supply input
20	VSS	Supply Ground
21	SSI_SPI_SEL	SSI/SPI select pin
22	U	U Commutation output (UVW mode)
23	V	V Commutation output (UVW mode)
24	W or PWM	W Commutation (UVW mode)/ PWM output
25	VSS	Supply Ground

Absolute Output Format

The AEAT-8800-Q24 provides SSI 3 wires and PWM outputs to indicate absolute position of the motor.

SSI 3 Wires (SSI)

SSI protocol uses three pins and is shared between SSI and SPI protocols. Use SSI_SPI_sel (the input pin) to select either protocol at a time. Assert 1 on SSI_SPI_sel to select SSI protocol, which supports up to 10-MHz clock rates.

- SSI_NSL_SPI_DIN → NSL (enable) signal for SSI protocol, input to AEAT-8800-Q24
- SSI_SCL_SPI_CLK → SCL (clock) signal for SSI protocol, input to AEAT-8800-Q24
- SSI_DO_SPI_DO → DO (data out) signal for SSI protocol, output from AEAT-8800-Q24

NOTE Notes for timing diagram in the following figure:

- NSL must held high for at least 3 ms after power up.
- NSL = 1 means it is in load mode and is used to obtain the position of the magnet.
- NSL = 0 is shift mode of the registers and with the SCL (clock) pin, the register will be clocked.
- tREQ ≥ 300 ns.
- tNSLH ≥ 200 ns.

The user is advised to read from the SSI falling edge.

Figure 6 SSI Protocol Timing Diagram

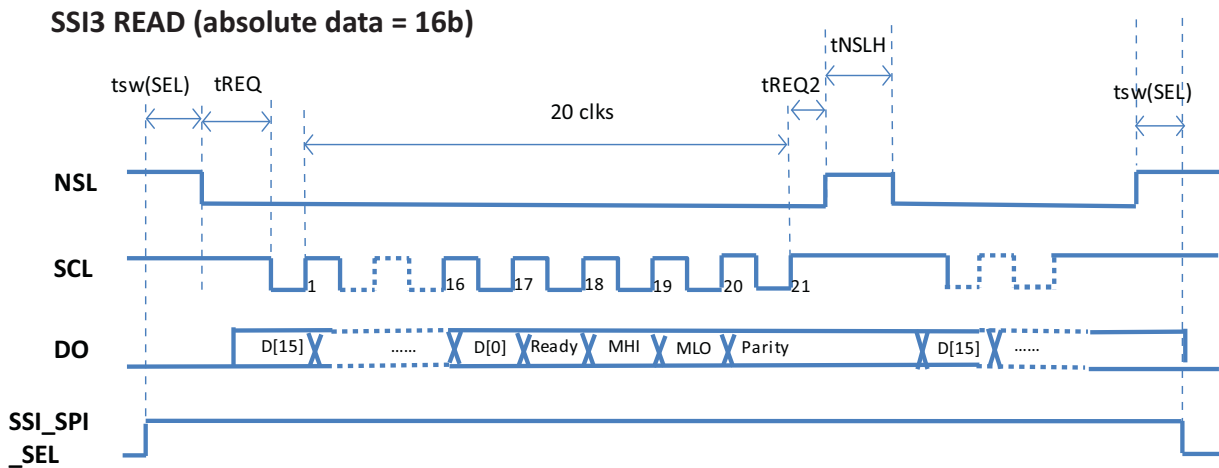

Table 5 Symbols and Description

Symbol	Description	Min.	Typ.	Max.	Unit
tsw(SEL)	SSI_SPI_SEL switch time	1	—	—	μs
tREQ	SCL high time between NLS falling edge and first SCL falling edge	300	—	—	ns
tREQ2	NSL low time after rising edge of last clock period for an SSI read	200	—	—	ns
tNSLH	NSL high time between 2 successive SSI reads	200	—	—	ns

NOTE CLK=1 when inactive; DIN=1 when inactive.

ATTENTION Make sure that CLK is high when switching between SSI and SPI modes.

SSI data format may vary depending on the different settings on absolute resolution (16 bits, 14 bits, 12 bits, or 10 bits).

The total data length is shown in the following figure.

Three bits status is for Ready, MHI, and MLO.

Figure 7 SSI Output Format for Different Absolute Resolution Settings

SSI3 READ Data Format

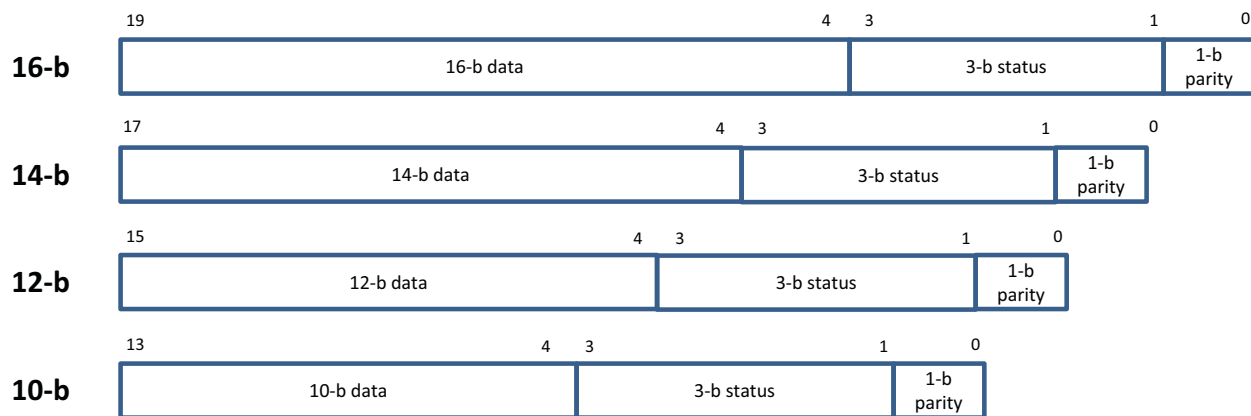

NOTE

- Total data length: 16-b pos → 20-b, 14-b pos → 18-b, 12-b pos → 16-b, 10-b pos → 14-b
- 3-b status: {Ready, MHI, MLO}
- **Magnet High (MHI) Error:** This indicates that the magnet strength detected by the chip is too strong. When this is flagged high consistently, change the weaker magnet or increase the distance between the chip and the magnet. The value for this alarm is represented as 1.
- **Magnet Low (MLO) Error:** This indicates that the magnet strength detected by the chip is too weak. When this is flagged high consistently, change the stronger magnet or decrease the distance between the chip and the magnet. The value for this alarm is represented as 1.
- **Ready:** The chip is ready, and the ready value is 1. 1-b parity is even parity.

PWM

PWM protocol uses one output pin (W_PWM) from AEAT-8800-Q24. Note that W_PWM pin is shared between UVW and PWM protocols. The PWM signals are configurable to have period of 1025, 2049, 4097, or 8193 μs . During power-up, the PWM signal is 0 before chip ready.

Figure 8 PWM Signals (Period = 1025/2049/4097/8193 μs)

- PWM period: 1025, 2049, 4097, 8193 μs

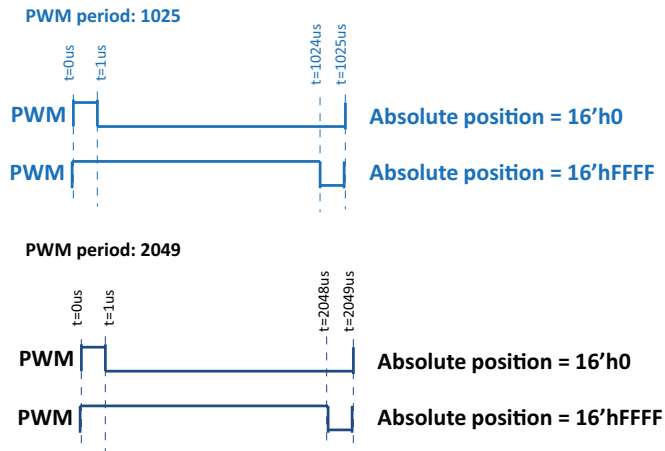

- PWM period: 1025, 2049, 4097, 8193 μs

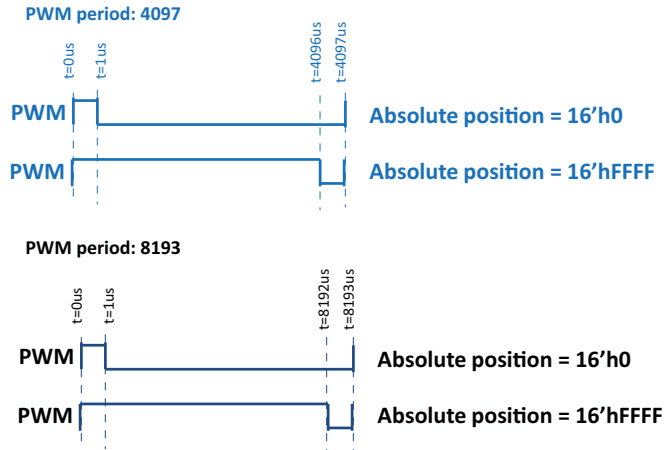

Incremental Output Format

The AEAT-8800-Q24 provides ABI and UVW signals to indicate incremental position of the motor.

ABI

The ABI incremental interface is available to provide position data and direction data from the three output pins (A, B, and I).

The index signal marks the absolute angular position and typically occurs once per revolution. The ABI signal is configurable using the memory map registers. It supports the following configuration:

- Programmable CPR: 32, 64, 128, 256, 512, 1024, 2048, or 4096
- Programmable I-width: 90, 180, 270, or 360 electrical degrees (edeg)

Figure 9 ABI Signal (4096 CPR, with Different I-Width Settings), Assuming User Sets Hysteresis at 0.02 Mechanical Degree

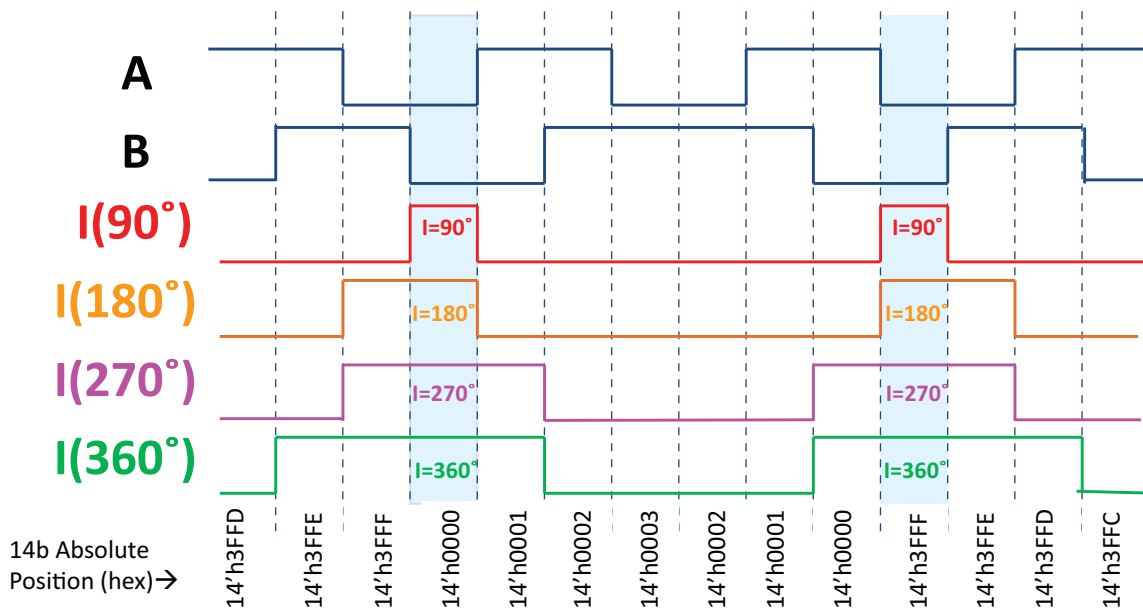

UVW

Three-channel integrated commutation output (U, V, W) emulates Hall sensor feedback and is available using three output pins. Note that W_PWM pin is shared between the UVW and PWM protocols.

AEAT-8800-Q24 can configure pole pairs from 1 to 8 equivalents to 2 to 16 poles.

Figure 10 UVW Signals (1~8 Pole-Pairs)

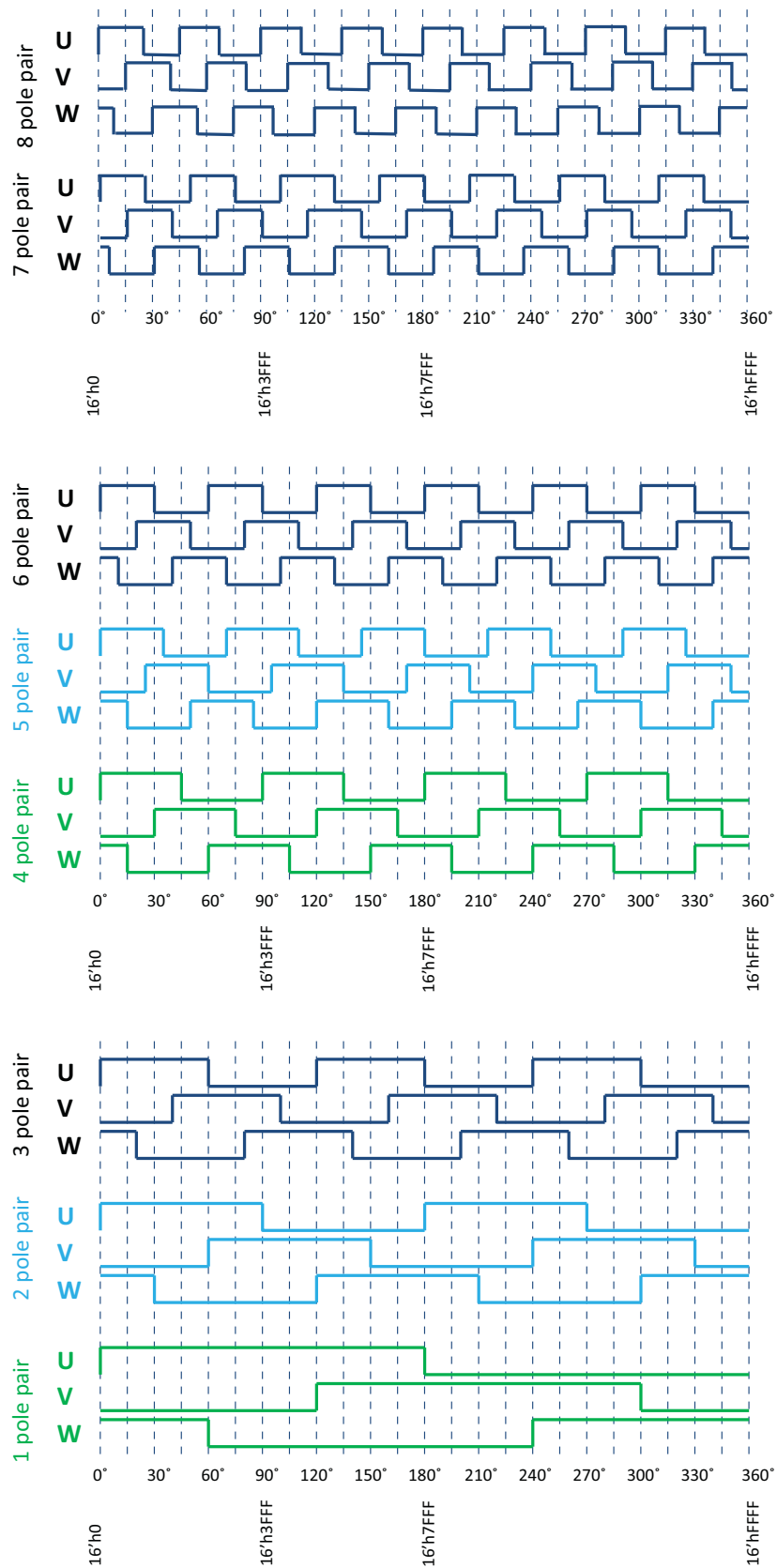

Note that signal U from UVW protocol is tagged to signal I from the ABI protocol as shown in the following figure.

Figure 11 U-to-I Tagging

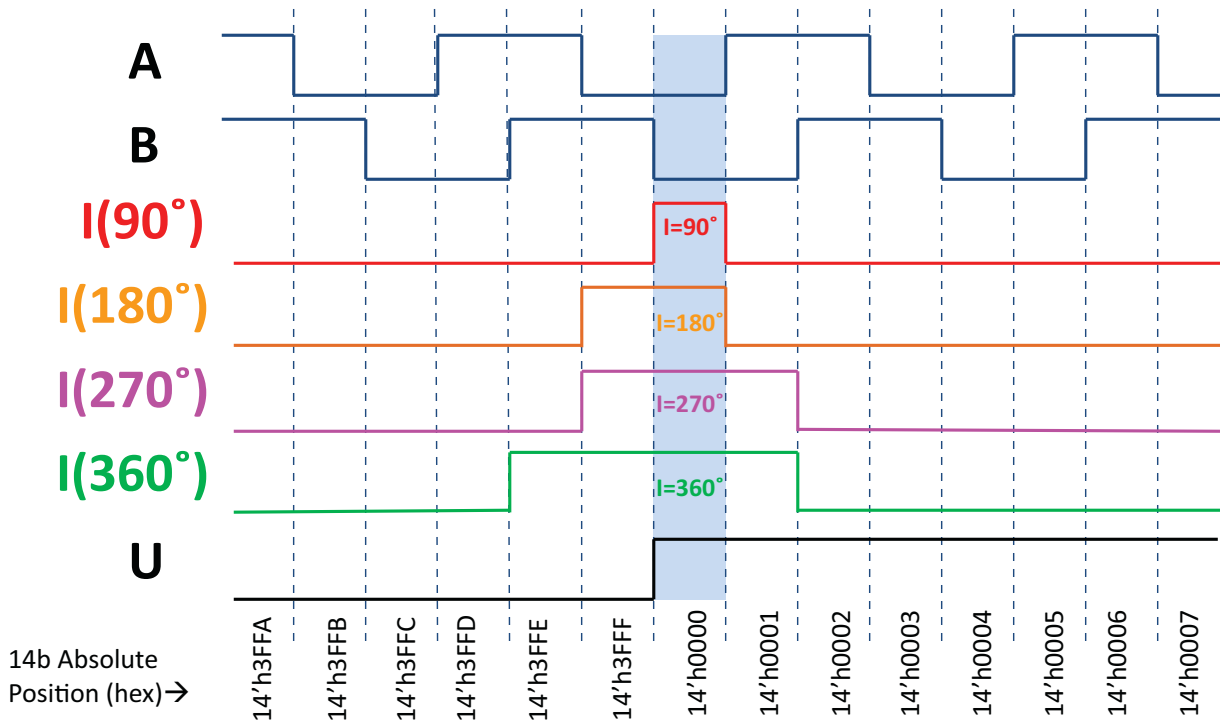

Programming the AEAT-8800-Q24

The OTP shadow registers and internal registers are programmable using the SPI protocol. Writing specific commands to specific addresses of internal registers will program values of OTP shadow registers to OTP permanently.

SPI Protocol

SPI protocol uses three pins from AEAT-8800-Q24. These three pins are shared between SSI and SPI protocols. SSI_SPI_sel (input pin) selects either protocol at a time. Assert 0 on SSI_SPI_sel to select the SPI protocol. The AEAT-8800-Q24 supports the SPI protocol from 10 kHz to 1 MHz.

- SSI_NSL_SPI_DIN → DIN (data in) signal for SPI protocol, input to AEAT-8800-Q24
- SSI_SCL_SPI_CLK → CLK (clock) signal for SPI protocol, input to AEAT-8800-Q24
- SSI_DO_SPI_DO → DO (data out) signal for SPI protocol, output from AEAT-8800-Q24

To read an address using SPI:

DIN: Read<2'b10>Address<5:0>; from 8 bits DIN
 Read 8-bit data on DO by clocking 8 SPI_CLK clock.

NOTE The user should read output data at the rising edge of SPI_CLK.

Figure 12 SPI Read Timing Diagram

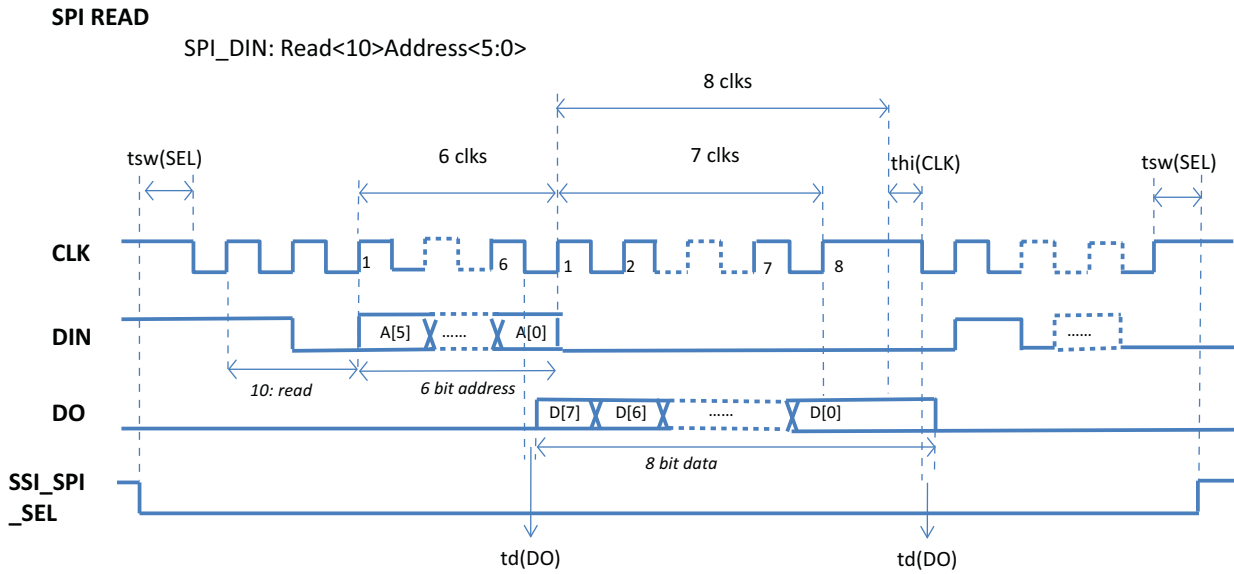

Table 6 Symbols and Description

Symbol	Description	Min.	Typ.	Max.	Unit
tsw(SEL)	SSI_SPI_SEL switch time	1	—	—	μs
td(DO)	DO data valid after falling edge of CLK The user should read output data at the rising edge of the SPI_CLK.	—	—	200	ns
thi(CLK)	CLK high time after end of last clock period for an SPI read/write command	300	—	—	ns

NOTE

- CLK=1 when inactive; DIN=1 when inactive.
- Important: Make sure CLK is high when switching between SSI and SPI modes.

To write to an address using SPI:

Write <2'b01>Address<5:0>; from 8 bits DIN

- SPI_DIN: Write<01>Address<5:0>Data<7:0>
 — Write is specified as 2 bits (01) in the MSB of the address bus, followed by the 6-bit address, and lastly 8-bit data.

NOTE The user should read back data to confirm data written successfully.

Figure 13 SPI Write Timing Diagram

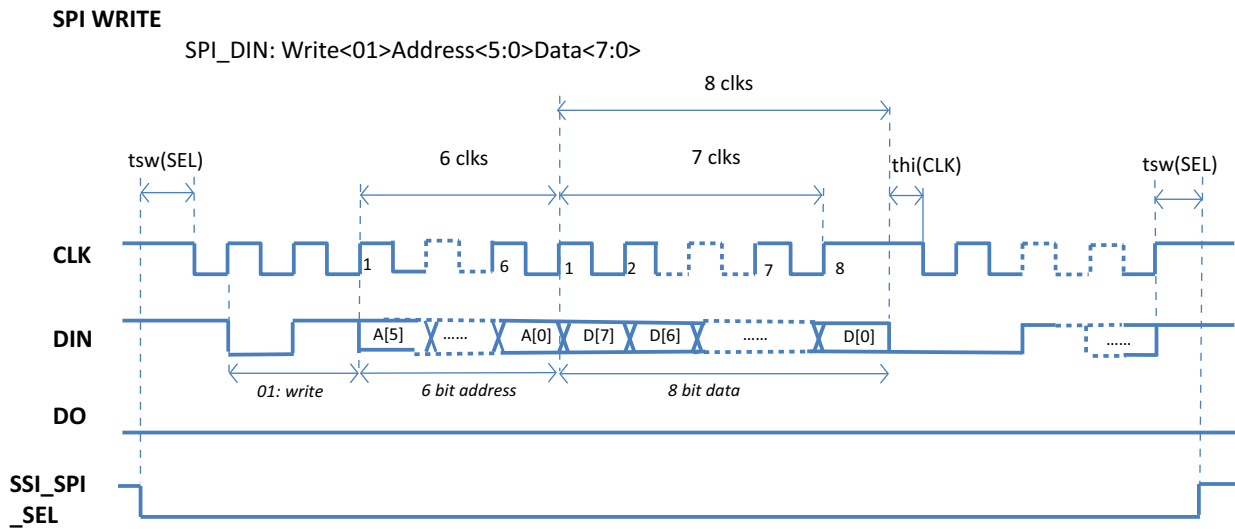

Table 7 Symbols and Description

Symbol	Description	Min.	Typ.	Max.	Unit
tsw(SEL)	SSI_SPI_SEL switch time	1			μs
td(DO)	DO data valid after falling edge of CLK			200	ns
thi(CLK)	CLK high time after end of last clock period for an SPI read/write command	300			ns

NOTE

- CLK=1 when inactive; DIN=1 when inactive.
- Important: Make sure CLK is high when switching between SSI and SPI modes.

Programming OTP via SPI

Here are steps for permanently program the OTP nonvolatile memory.

Change the voltage at VDDA pin to $5.6V \pm 0.1V$ for OTP programming.

See the memory map address as described in [Memory Map](#).

The following are details on the register 0x10 to 0x1B.

Table 8 Register 0x10 to 0x1B Details

Address	Bits	Name	Description	Default
0x10	7:0	Unlock Registers	Write 0xAB to this address to unlock all OTP shadow registers and internal registers (except 0x00~0x03, 0x10, 0x11, 0x12, and 0x1B, which are not locked).	8'h0
0x11	7:0	Program Customer Reserved OTP (0x00, 0x01)	Write 0xA1 to this address to program customer reserved OTP (0x00, 0x01) to OTP.	8'h0
0x12	7:0	Program ST Zero Reset OTP (0x02, 0x03)	Write 0xA2 to this address to program ST Zero Reset OTP (0x02, 0x03) to OTP.	8'h0
0x13	7:0	Program Customer Configuration OTP (0x04, 0x05, 0x06)	Write 0xA3 to this address to program Customer Configuration OTP (0x04, 0x05, 0x06) to OTP.	8'h0
0x14	7:0	Program Operating Voltage	Write 0xA4 to address 0x14.	8'h0
0x1B	7:0	Program Configuration of Full Calibration OTP	Write 0xA5 to this address to program full calibration results to OTP.	8'h0

Package Drawings (in mm)

Figure 14 AEAT-8800, 24 QFN Dimensions

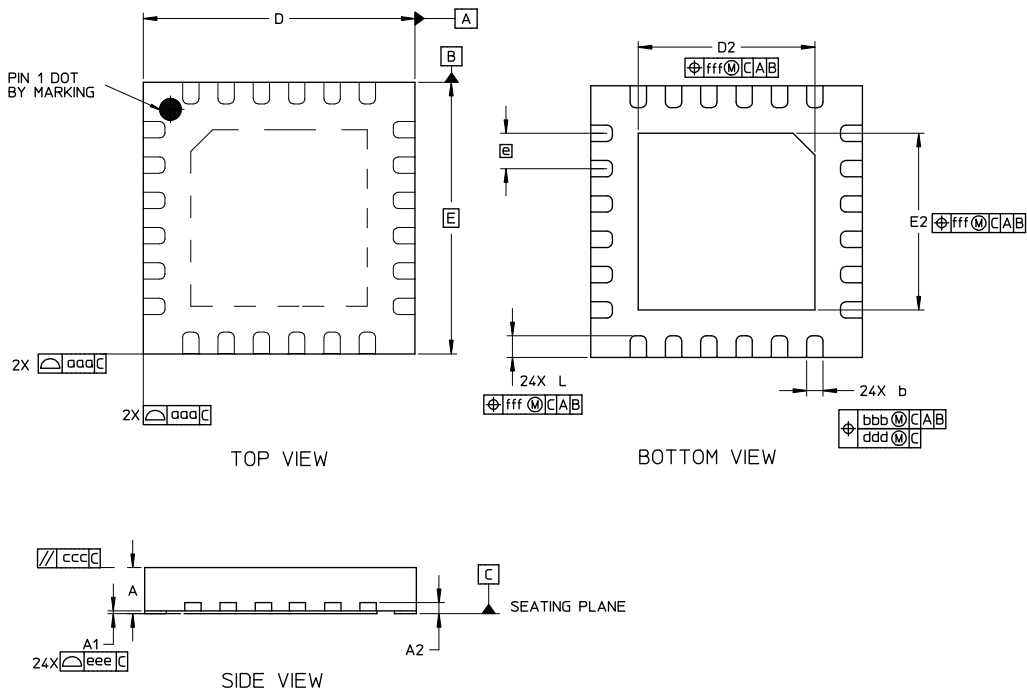

Table 9 Dimensions and Tolerances

Dimension Reference			
REF	Min.	Nom.	Max.
A	0.800	0.850	0.900
A1	0.000	—	0.050
A2	0.203 REF		
D	5.000 BSC		
E	5.000 BSC		
D2	3.200	3.250	3.300
E2	3.200	3.250	3.300
b	0.250	0.300	0.350
e	0.650 BSC		
L	0.350	0.400	0.450

Dimension Tolerance	
REF	Tolerance
aaa	0.100
bbb	0.100
ccc	0.050
ddd	0.050
eee	0.080
fff	0.050

Recommended PCB Land Pattern (in mm)

Figure 15 Land Pattern Dimensions

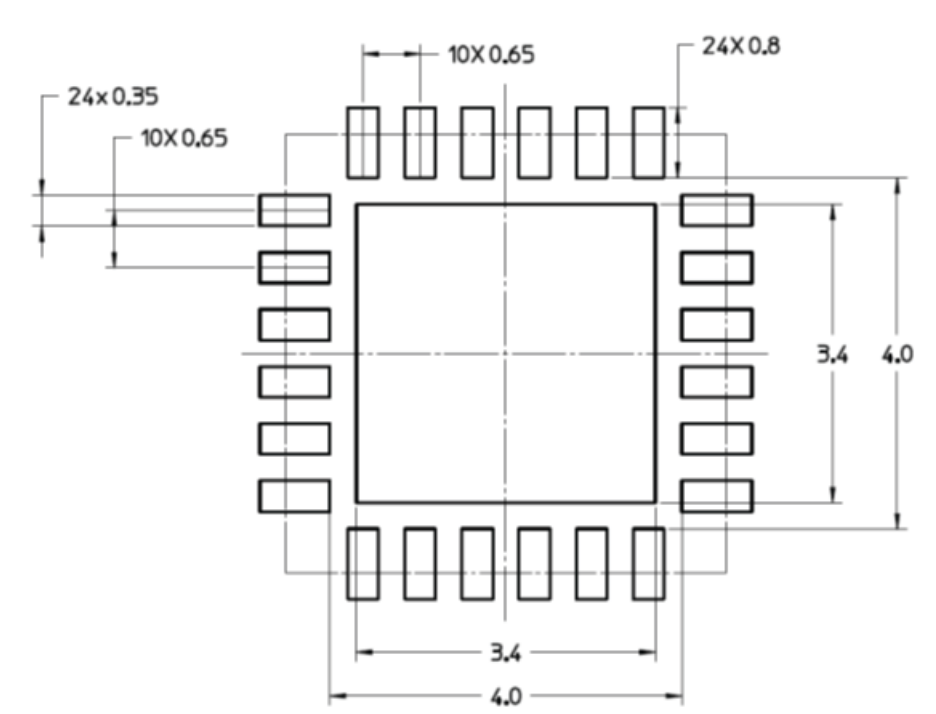

For product information and a complete list of distributors, please go to our web site:
www.broadcom.com.

Broadcom, the pulse logo, Connecting everything, Avago Technologies, Avago, and the A logo are among the trademarks of Broadcom and/or its affiliates in the United States, certain other countries and/or the EU.

Copyright © 2016–2017 by Broadcom. All Rights Reserved.

The term "Broadcom" refers to Broadcom Limited and/or its subsidiaries. For more information, please visit www.broadcom.com.

Broadcom reserves the right to make changes without further notice to any products or data herein to improve reliability, function, or design.

Information furnished by Broadcom is believed to be accurate and reliable. However, Broadcom does not assume any liability arising out of the application or use of this information, nor the application or use of any product or circuit described herein, neither does it convey any license under its patent rights nor the rights of others.

pub-005906 – May 17, 2017

