



Chipsmall Limited consists of a professional team with an average of over 10 year of expertise in the distribution of electronic components. Based in Hongkong, we have already established firm and mutual-benefit business relationships with customers from,Europe,America and south Asia,supplying obsolete and hard-to-find components to meet their specific needs.

With the principle of "Quality Parts,Customers Priority,Honest Operation,and Considerate Service",our business mainly focus on the distribution of electronic components. Line cards we deal with include Microchip,ALPS,ROHM,Xilinx,Pulse,ON,Everlight and Freescale. Main products comprise IC,Modules,Potentiometer,IC Socket,Relay,Connector.Our parts cover such applications as commercial,industrial, and automotives areas.

We are looking forward to setting up business relationship with you and hope to provide you with the best service and solution. Let us make a better world for our industry!



Contact us

Tel: +86-755-8981 8866 Fax: +86-755-8427 6832

Email & Skype: info@chipsmall.com Web: www.chipsmall.com

Address: A1208, Overseas Decoration Building, #122 Zhenhua RD., Futian, Shenzhen, China



AEDT-9340 Series

High Temperature 115°C

1250/2500 CPR 6-Channel Commutation Encoder



Data Sheet



Description

The AEDT-9340 optical encoder series are high temperature six channel optical incremental encoder modules. When used with a codewheel, these modules detect rotary position. Each module consists of a lensed LED source and a detector IC enclosed in a small plastic package. Due to a highly collimated light source and a unique photo detector array, these modules are extremely tolerant to mounting misalignment.

The AEDT-9340 encoder has integrated commutation output channels (U,V,W), two-channel quadrature outputs (A,B), plus a third channel index output (I). This ungated index output is a positive index pulse that is generated once for each full rotation of the codewheel.

The AEDT-9340 encoder is designed for use with a code-wheel that has an optical radius of 15 mm (0.590 inch) for 1250/2500 CPR, 12.3 mm (0.484 inch) for 1024/2048 CPR and 12mm (0.472 inch) for 1000/2000 CPR.

The quadrature, index, commutation signals and power supplied to encoder are accessed through eight 0.46mm square male connector pins located on 1.27mm pitch.

The AEDT-9340 optical encoder provides advanced motion control detection. The integrated commutation outputs (U,V, and W) is equivalent to those produced by Hall Switches. Thus, this makes to encoder ideal for servo motor applications. Application of the AEDT-9340 solution also enables the system to be more compact, with a significantly reduced alignment time. This is due to the provision of alignment jigs for easier assembly into housed encoders. The encoder also provides superior switching accuracy due to a much lower hysteresis when compared to a Hall Switches. The commutation signals can easily be interchanged for Brushless DC motor of different rotor pole-pairs by simply switching to matching pole-pair codewheels.

Features

- Two-channel quadrature output with ungated index pulse (A,B,I)
- Three-channel integrated commutation Output (UVW)
- Up to 2500 Cycles Per Revolution (CPR)
- Easy assembly with alignment jig
- Design to fit into circular shaped housing
- Up to 200 kHz frequency response
- -40°C to 115°C operating temperature
- TTL Compatible
- Single 5V Supply
- Integrated feedback device for Brushless DC Motor
- RoHS Compliant

Applications

Typical applications include industrial printers, plotters, tape drives, industrial and factory automation equipment.

Note:

Avago Technologies encoders are not recommended for use in safety critical application, e.g., ABS braking systems, power steering, life support systems and critical care medical equipment. Please contact sales representative if more clarification is needed.

Theory of Operation

The AEDT-9340 optical encoder is an emitter/detector module. Coupled with a codewheel, these modules translate the rotary motion of a shaft into a six-channel digital output.

The modules contain a single Light Emitting Diode (LED) as its light source. The light is collimated into a parallel beam by means of a single polycarbonate lens located directly over the LED. Opposite the emitter is the integrated detector circuit. This IC consists of multiple sets of photo detectors and the signal processing circuitry necessary to produce the digital waveforms.

The codewheel rotates between the emitter and detector, causing the light beam to be interrupted by the pattern of spaces and bars on the codewheel.

The photodiodes that detect these interruptions are arranged in a pattern that corresponds to the radius and design of the code-wheel. These detectors are also deliberately spaced such that a light period on one pair of detectors corresponds to a dark period on the adjacent pair of detectors.

The photodiode outputs are then fed through the signal processing circuitry resulting in A, /A, B, /B, I, and /I. Comparators receive these signals and produce the final outputs for channels A and B. Due to this integrated phasing technique, the digital output of channel A is in quadrature with that of channel B (90 mechanical degrees out of phase). The commutation feedback (U, V, W) signals are generated based on the codewheel design.

Definitions

Count (N): The number of electrical cycles per revolution (CPR). CPR refers to the raw signal from encoder that is the cycles before 4x decode.

One Cycle: 360 electrical degrees ($^{\circ}$ e).

One Shaft Rotation: 360 mechanical degrees.

Cycle Error (ΔC): An indication of cycle uniformity. The difference between an observed shaft angle which gives rise to one electrical cycle, and the nominal angular increment of $1/N$ of a revolution.

Pulse Width (P): The number of electrical degrees that an output is high during 1 cycle. This value is nominally 180° e or $1/2$ cycle.

Pulse Width Error (ΔP): The deviation, in electrical degrees, of the pulse width from its ideal value of 180° e.

State Width (S): The numbers of electrical degrees between transitions in the output of channel A and the neighboring transition in the output of channel B. There are 4 states per cycle, each nominally 90° e.

State Width Error (ΔS): The deviation, in electrical degrees, of each state width from its ideal value of 90° e.

Commutation Accuracy (ΔI): The deviation, in mechanical degrees, after shaft rotates passes the reference point (Index channel) to the first U channel pulse. The measurement from middle of channel I to channel U.

Phase (ϕ): The numbers of electrical degrees between the center of the high state of channel A and the center of the high state of channel B.

This value is nominally 90° e for quadrature output.

Phase Error ($\Delta\phi$): The deviation of the phase from its ideal value of 90° e.

Direction of Rotation: When the codewheel rotates in the clockwise direction viewing from top of the module, channel A will lead channel B. If the codewheel rotates in the opposite direction, channel B will lead channel A.

Optical Radius (Rop): The distance from the codewheel's center of rotation to the optical center (O.C) of the encoder module.

Index Pulse Width (Po): The number of electrical degrees that an index is high with reference to channel A or channel B during one full shaft rotation

AEDT-9340 Technical Specifications

Absolute Maximum Ratings

Parameter	Symbol	Min.	Max.	Units	Notes
Storage Temperature	T_S	-40	115	°C	
Operating Temperature	T_A	-40	115	°C	
Supply Voltage	V_{CC}	-0.5	7	Volts	

Recommended Operating Conditions

Parameter	Symbol	Min.	Typ.	Max.	Units	Notes
Temperature		-40	25	115	°C	
Supply Voltage (Detector)		4.5	5.0	5.5	Volts	Ripple < 100mVpp
Operating Frequency 1000/1024/1250 CPR 2000/2048/2500 CPR				100 200	kHz	Velocity (rpm) x N/60
Shaft Radial Play Plus Eccentricity				0.05	mm TIR	
Shaft Axial Play				±0.100	mm	

Electrical Characteristics

Electrical characteristics over recommend operating range, typical at 25°C

Parameter	Symbol	Min.	Typ	Max.	Units	Notes
Supply Current	I_{CC}	30	40	60	mA	
High Level Output Voltage	V_{OH}	2.4			V	
Low Level Output Voltage	V_{OL}			0.4	V	
Rise Time	t_r		200		ns	$C_L = 14\text{pF}$
Fall Time	t_f		20		ns	
Loading Capacitance	C_{LOAD}			50	pF	

Encoding Characteristics (Channel A and B)

Encoding characteristics over the recommended operating conditions and mounting tolerances. These characteristics include codewheel contribution. The typical values are average over the full rotation of the codewheel.

Parameter	Symbol	Min.	Typ.	Max.	Units	Notes
Pulse Width Error	ΔP		7	50	°e	
Logic State Width Error	ΔS		5	50	°e	
Phase Error	$\Delta\phi$		2	30	°e	
Cycle Error	ΔC		20	50	°e	
Position Error	$\Delta\theta$		20	50	min. of arc	
Index Pulse Width						
1000/1024/1250 CPR	P_0	90	150	360	°e	
2000/2048/2500 CPR	P_0	180	300	540	°e	

Commutation Characteristics (Channel U, V, W)

Encoding characteristics over the recommended operating conditions and mounting tolerances. These characteristics include codewheel contribution. The typical values are average over the full rotation of the codewheel.

Parameter	Symbol	Minimum	Maximum	Units
Commutation Format		Three Phase 4, 6, 8, 10 poles		
Commutation Accuracy (middle of channel I to channel U)	ΔI	-1	+1	°mechanical
Commutation Accuracy (Channel U,V and W)	ΔUVW	-2	+2	°mechanical

Device Pinout

Pin #1 start from left side.

Pin	Function
1	U
2	I
3	V
4	W
5	Ground
6	Vcc
7	A
8	B

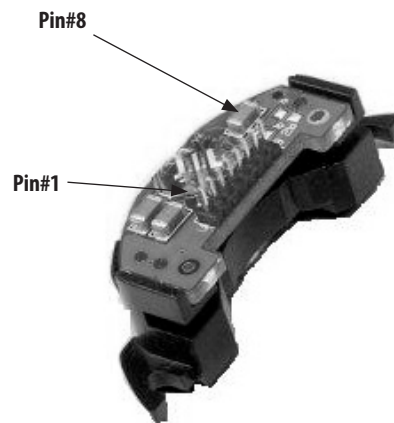

Mating Connector

Due to female connector availability, a 8 x 2 (1.27 mm x 1.27 mm) female IDC Connector is recommended. The cable used is 0.635 mm pitch flat ribbon cable.

Package Dimensions

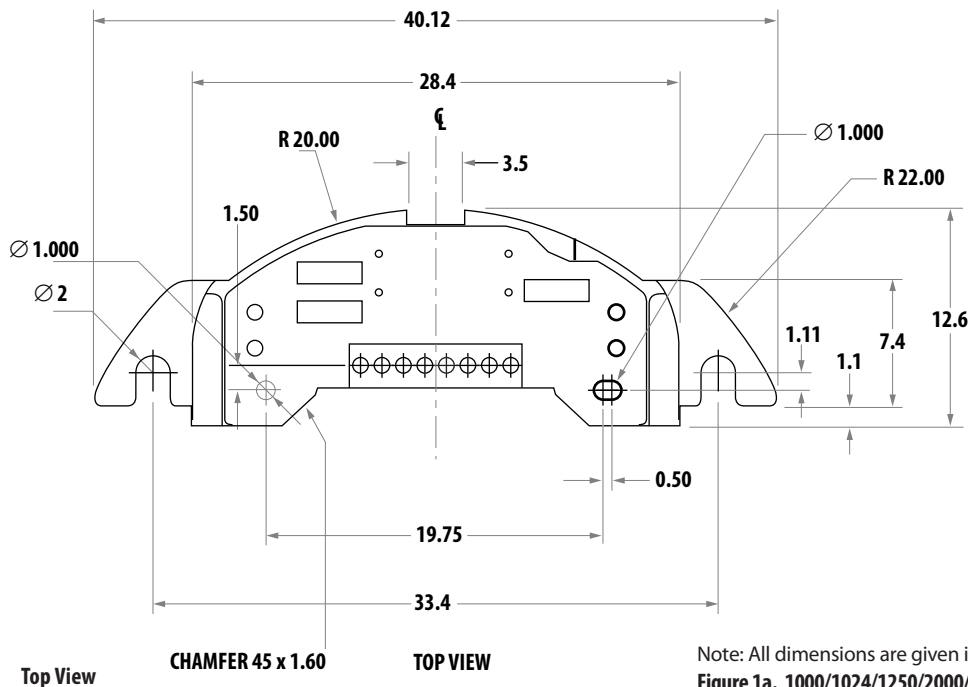
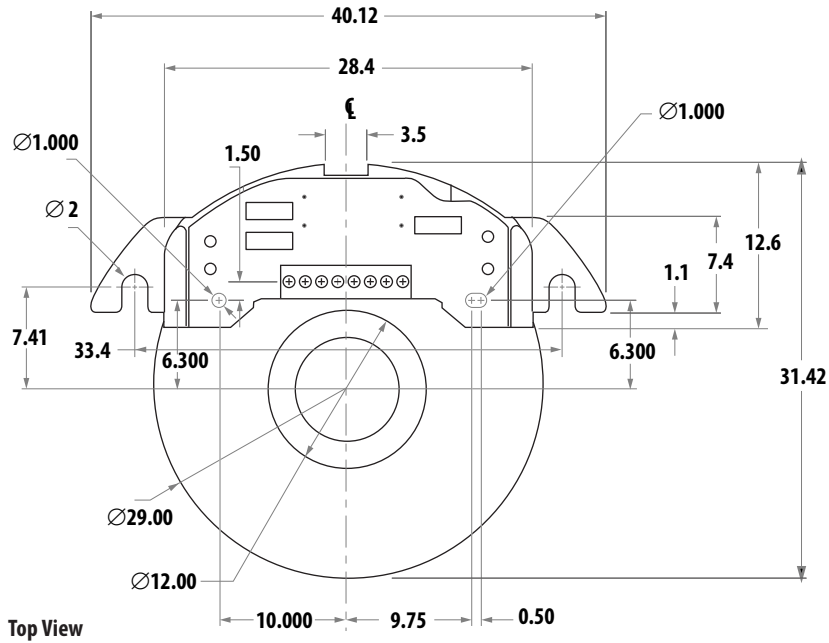

Figure 1a. 1000/1024/1250/2000/2048/2500 CPR encoder module dimensions

Package Dimensions



Note: All dimensions are given in mm

Figure 4a. 1000/2000 CPR encoder module with codewheel dimensions

Mounting Considerations

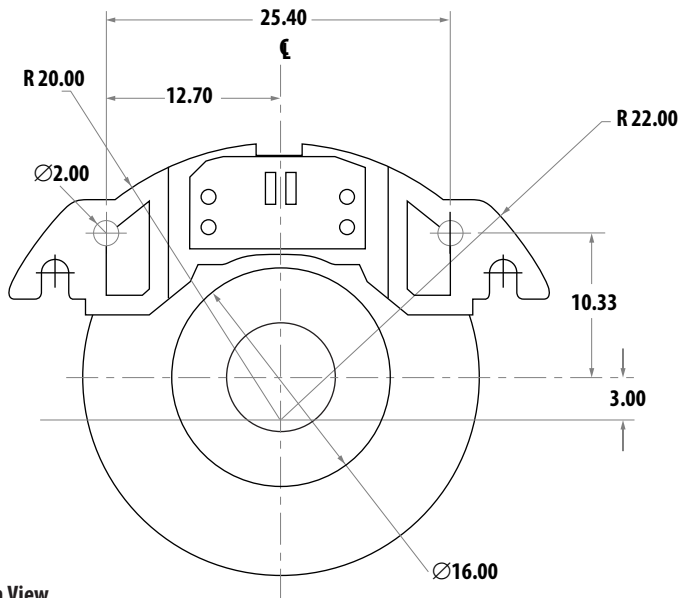

Recommended screw size : M1.6 x 0.35

Recommended mounting screw torque : 1Lbin (0.133 Nm)

Notes:

5. All dimensions are given in mm

6. Refer to AEDT-9340 application note for step by step alignment and installation procedure

Figure 4b. 1000/2000 CPR encoder module mounting considerations

Codewheel Mounting Considerations

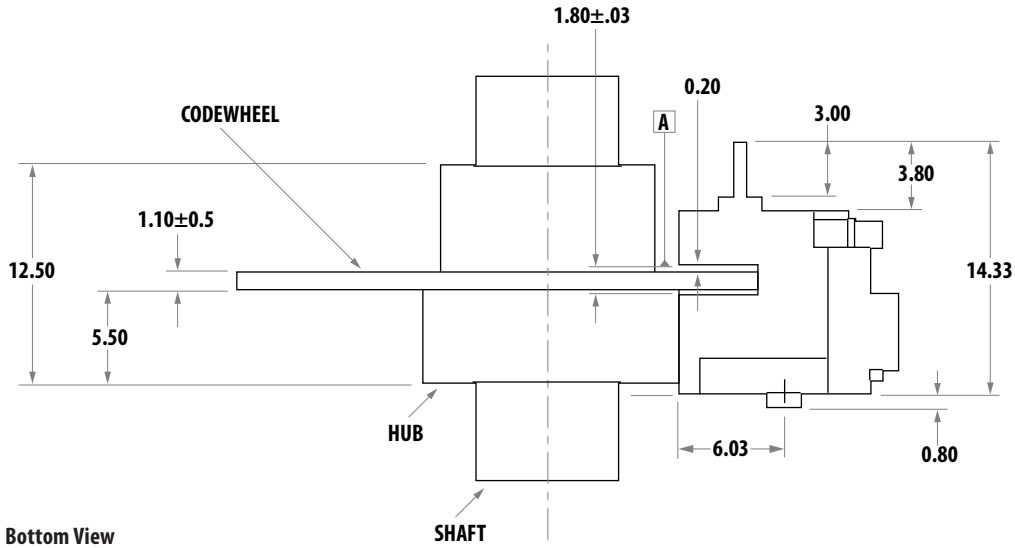

Note:

1. All dimensions are given in mm
2. Codewheel gap is aligned at 0.2mm from DATUM A

Figure 5. 1000/1024/1250/2000/2048/2500 CPR encoder module and codewheel mounting considerations

Codewheel Mechanical Drawing

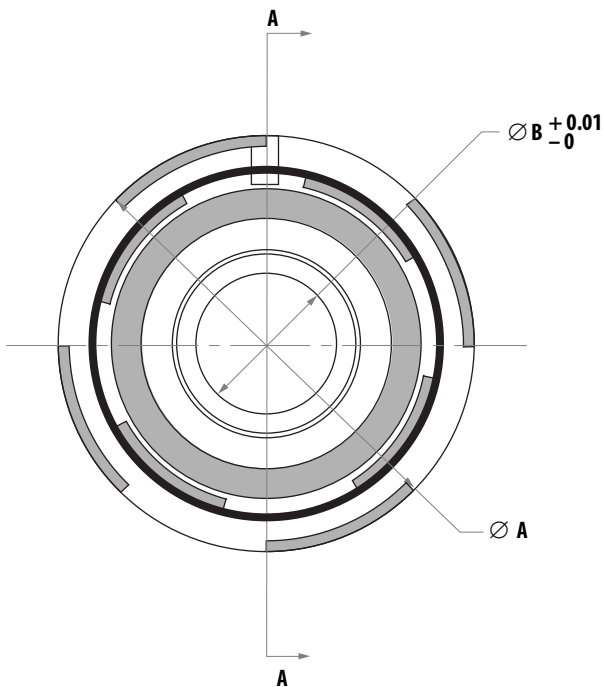

CODEWHEEL	OUTER DIAMETER
1250/2500	35 mm
1024/2048	29.4mm
1000/2000	29mm

Notes:

All dimensions are given in millimeters (mm)

Ø B = Hub internal diameter

(Based on the shaft diameter option selected)

Ø A = Codewheel outer diameter

Output Waveform Specification

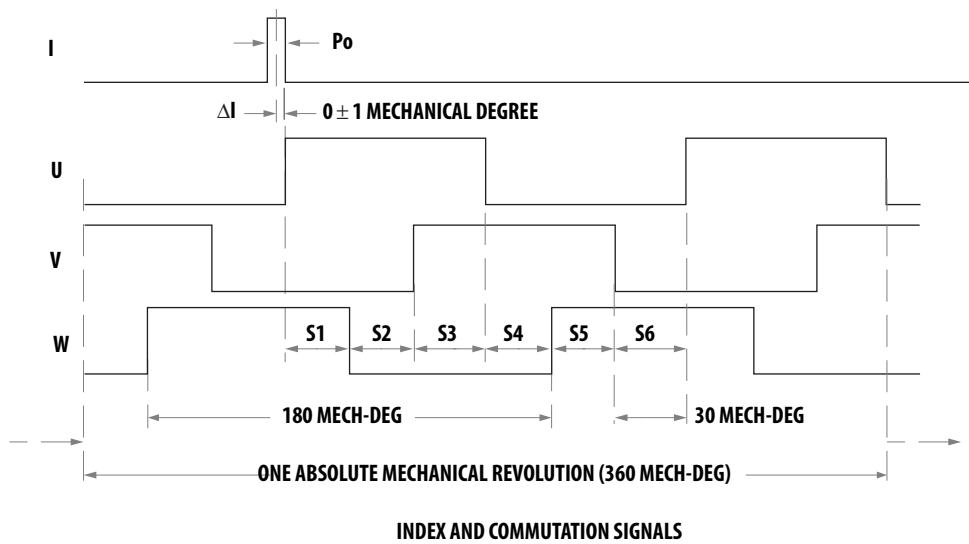
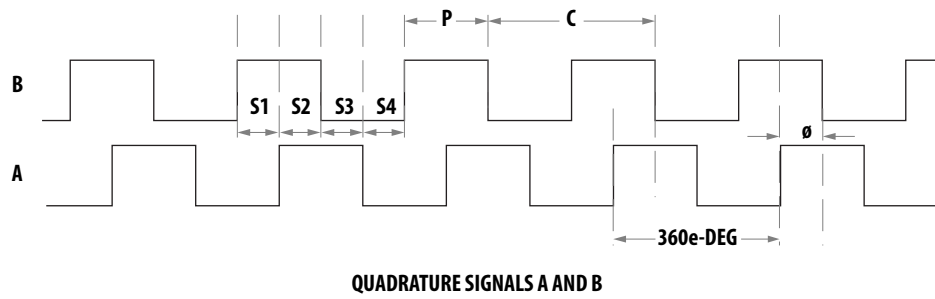

Figure 6. Output waveform specification of 2 pole-pairs (4 poles) for counter clockwise rotation, viewed from the top

Note: In the above waveform, quadrature signals A, B are not drawn to scale with respect to index pulse and commutation signals.

Pole	Number of States/ Mechanical Revolution	State Width (Mechanical Degree)
4	12	30
6	18	20
8	24	15
10	30	12

Ordering Information

Encoder Only

AEDT-9340 - - 00

W = 2500 CPR
U = 2048 CPR
T = 2000 CPR
L = 1250 CPR
J = 1024 CPR
B = 1000 CPR

For product information and a complete list of distributors, please go to our web site: www.avagotech.com

Avago, Avago Technologies, and the A logo are trademarks of Avago Technologies Limited in the United States and other countries. Data subject to change. Copyright © 2005-2008 Avago Technologies Limited. All rights reserved. AV02-1102EN - April 4, 2008

Avago
TECHNOLOGIES