



Chipsmall Limited consists of a professional team with an average of over 10 year of expertise in the distribution of electronic components. Based in Hongkong, we have already established firm and mutual-benefit business relationships with customers from,Europe,America and south Asia,supplying obsolete and hard-to-find components to meet their specific needs.

With the principle of “Quality Parts,Customers Priority,Honest Operation,and Considerate Service”,our business mainly focus on the distribution of electronic components. Line cards we deal with include Microchip,ALPS,ROHM,Xilinx,Pulse,ON,Everlight and Freescale. Main products comprise IC,Modules,Potentiometer,IC Socket,Relay,Connector.Our parts cover such applications as commercial,industrial, and automotives areas.

We are looking forward to setting up business relationship with you and hope to provide you with the best service and solution. Let us make a better world for our industry!



Contact us

Tel: +86-755-8981 8866 Fax: +86-755-8427 6832

Email & Skype: info@chipsmall.com Web: www.chipsmall.com

Address: A1208, Overseas Decoration Building, #122 Zhenhua RD., Futian, Shenzhen, China



3-Terminal EMI Filter

AEMIF-0603



RoHS/RoHS II Compliant



1.6 x 0.8 x 0.6mm

FEATURES:

- Multilayer and low profile structure enables high density mounting
- Closed magnetic circuit minimizes crosstalk
- Sharp attenuation characteristic beyond cutoff frequency achieves excellent EMI suppression

APPLICATIONS:

- Noise removal from signal lines in digital cameras, computers, game consoles, LED TVs, etc.
- Suppression of noise generated by high speed digital circuits such as clock lines

STANDARD SPECIFICATIONS:

Operating Temperature
-40°C to +85°C

Storage Temperature
-10°C to +40°C, 70% RH max. in tape and reel

| Part Number | -3dB Cut-off Frequency | Cut-off Frequency Tolerance | Rated Voltage | Rated Current | Min. Insulation Resistance | Max. DC Resistance | Attenuation |
|--------------------|------------------------|-----------------------------|---------------|---------------|----------------------------|--------------------|------------------------------|
| Units | MHz | % | V | mA | MΩ | Ω | dB |
| AEMIF-0603-401M-16 | 400 | M | 16 | 300 | 200 | 0.8 | 20.0 dB min. at 800-2000 MHz |

Test Equipment

| Items | Test Equipment |
|-----------------------|-----------------------|
| Cut off Frequency | HP8753E or equivalent |
| DC Resistance | HP4338 or equivalent |
| Insulation Resistance | TH2682 or equivalent |
| Attenuation | HP8753E or equivalent |

PART NUMBER IDENTIFICATION

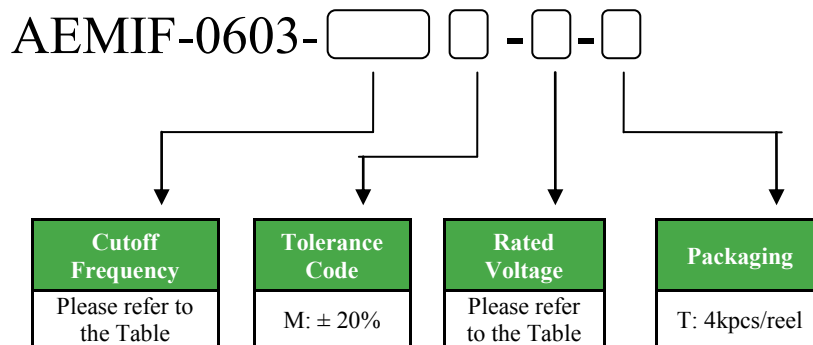

3-Terminal EMI Filter

AEMIF-0603

 RoHS/RoHS II Compliant



1.6 x 0.8 x 0.6mm

FREQUENCY CHARACTERISTIC

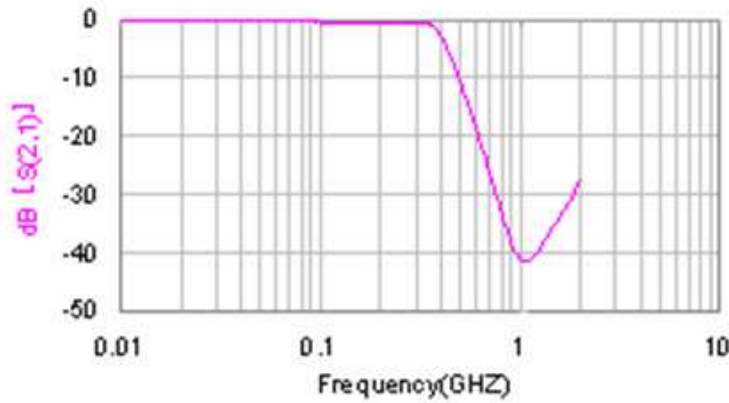

OUTLINE DIMENSION:

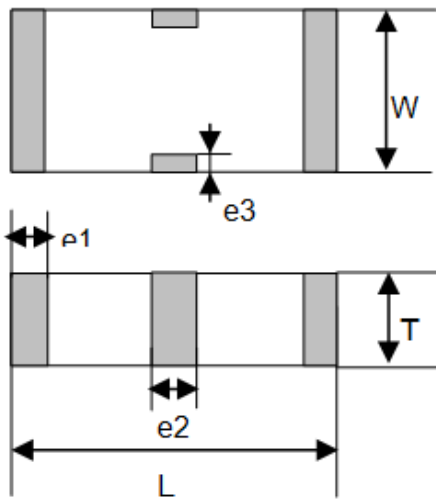

Recommended Land Pattern

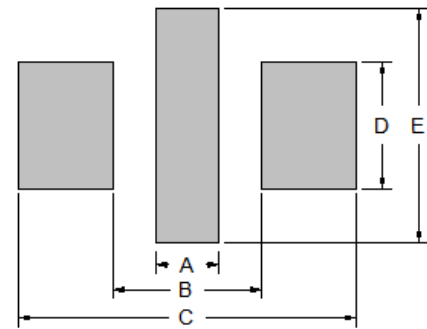

| L | W | T | e1 | e2 | e3 |
|---------|---------|---------|----------|---------|----------|
| 1.6±0.2 | 0.8±0.2 | 0.6±0.2 | 0.2±0.15 | 0.4±0.2 | 0.2±0.15 |

| A | B | C | D | E |
|-----|-----|-----|-----|-----|
| 0.4 | 1.0 | 2.2 | 0.6 | 1.5 |

Dimension: mm

EQUIVALENT CIRCUIT:

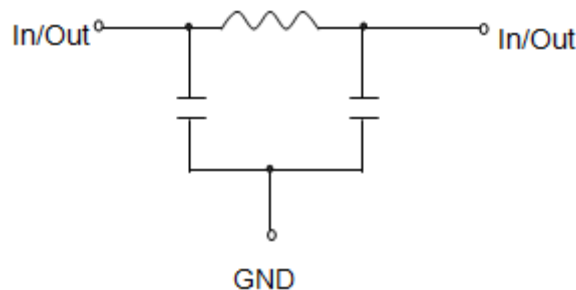

No polarity

3-Terminal EMI Filter

AEMIF-0603



RoHS/RoHS II Compliant



1.6 x 0.8 x 0.6mm

REFLOW PROFILE:

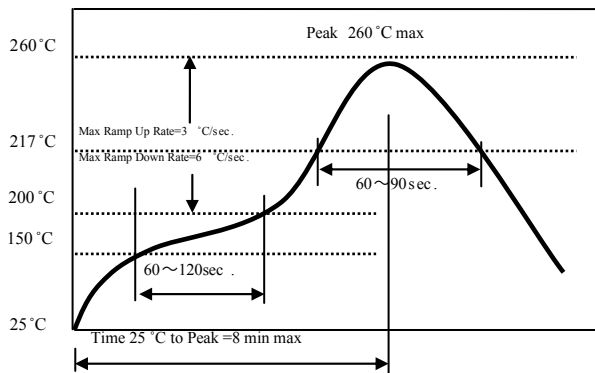

- Preheat condition: 150 ~200°C/60~120sec.
- Allowed time above 217 °C: 60~90sec.
- Max temp: 260 °C
- Max time at max temp: 10sec.
- Solder paste: Sn/3.0Ag/0.5Cu
- Allowed Reflow time: 2x max

TAPE & REEL

T= tape and reel (4,000pcs/reel)

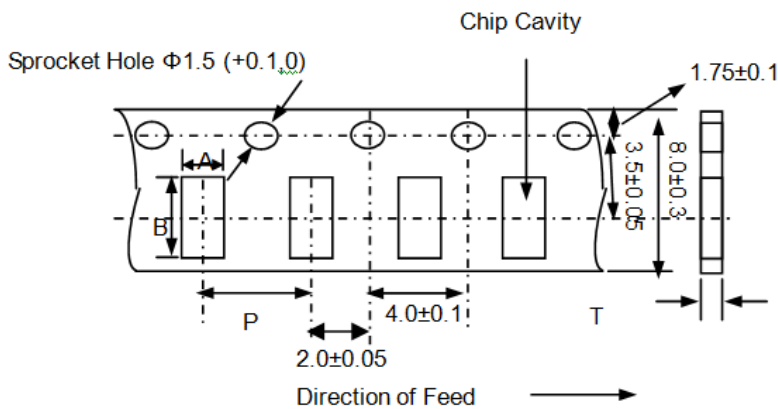

| A | B | P | T max |
|-----|------|-----|-------|
| 1.0 | 1.80 | 4.0 | 0.75 |

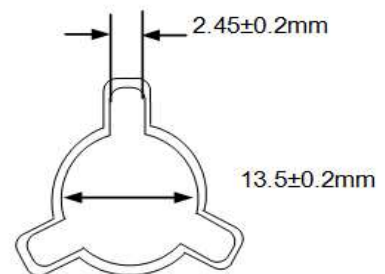
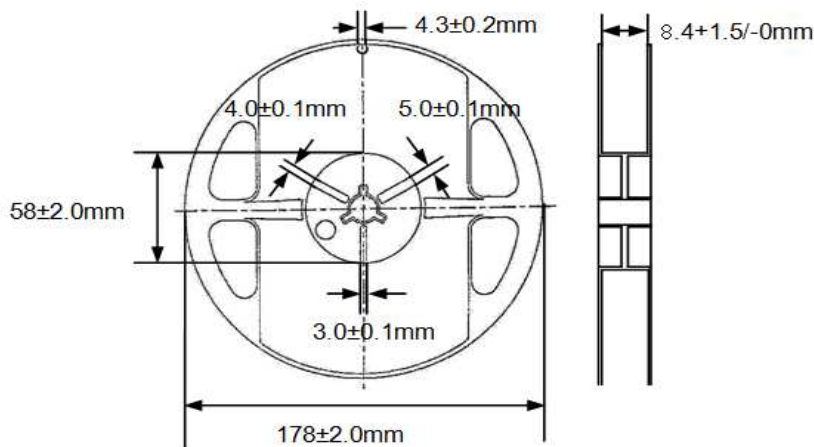

Dimension: mm

ATTENTION: Abracon Corporation's products are COTS – Commercial-Off-The-Shelf products; suitable for Commercial, Industrial and, where designated, Automotive Applications. Abracon's products are not specifically designed for Military, Aviation, Aerospace, Life-dependant Medical applications or any application requiring high reliability where component failure could result in loss of life and/or property. For applications requiring high reliability and/or presenting an extreme operating environment, written consent and authorization from Abracon Corporation is required. Please contact Abracon Corporation for more information.

ABRACON IS
ISO 9001:2008
CERTIFIED



Visit www.abracon.com for Terms & Conditions of Sale **Revised: 07.25.14**
30332 Esperanza, Rancho Santa Margarita, California 92688
tel 949-546-8000 | fax 949-546-800 | www.abracon.com