



Chipsmall Limited consists of a professional team with an average of over 10 year of expertise in the distribution of electronic components. Based in Hongkong, we have already established firm and mutual-benefit business relationships with customers from,Europe,America and south Asia,supplying obsolete and hard-to-find components to meet their specific needs.

With the principle of "Quality Parts,Customers Priority,Honest Operation,and Considerate Service",our business mainly focus on the distribution of electronic components. Line cards we deal with include Microchip,ALPS,ROHM,Xilinx,Pulse,ON,Everlight and Freescale. Main products comprise IC,Modules,Potentiometer,IC Socket,Relay,Connector.Our parts cover such applications as commercial,industrial, and automotives areas.

We are looking forward to setting up business relationship with you and hope to provide you with the best service and solution. Let us make a better world for our industry!



Contact us

Tel: +86-755-8981 8866 Fax: +86-755-8427 6832

Email & Skype: info@chipsmall.com Web: www.chipsmall.com

Address: A1208, Overseas Decoration Building, #122 Zhenhua RD., Futian, Shenzhen, China



AFBR-1528CZ and AFBR-2528CZ



DC to 10-MBd Versatile Link Fiber Optic Analog Transmitter and Digital Receiver for 1-mm POF and 200- μ m PCS

Data Sheet

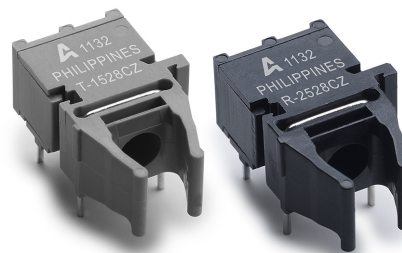

Description

The AFBR-1528CZ analog transmitter utilizes a 650-nm LED source, and the AFBR-2528CZ receiver consists of an IC with an integrated photodiode providing a TTL logic family compatible output.

AFBR-2528CZ devices have inverted output signals, which means that light_on leads to Data_out low.

The transmitter and receiver housing is designed to efficiently couple into 1-mm Polymer Optical Fiber (POF) and 200- μ m diameter Plastic-Clad Silica (PCS). Links up to 58 m are supported with 1-mm POF, and up to 500 m with 200- μ m PCS.

A link with AFBR-1528CZ and AFBR-2528CZ enables operating temperatures up to +95 °C.

The transmitter and receiver are 4-pin devices, packed in Versatile Link housings. Versatile Link components can be interlocked (N-plexed together) to minimize space and to provide dual connections with the duplex connectors. Various simplex and duplex connectors, as well as POF cables, are available for Versatile Link components.

Available Transmitter Option:

Horizontal Package	AFBR-1528CZ
--------------------	-------------

Available Receiver Option:

Horizontal Package	AFBR-2528CZ
--------------------	-------------

Features

- RoHS-compliant
- Data transmission at signal rates from DC up to 10 MBd
- Up to 58 meters distance with 1-mm Polymer Optical Fiber (POF) and up to 500 meters with 200- μ m PCS
- Operating temperature range of -40 °C to +95 °C
- Compatible with the Avago Technologies Versatile Link family of connectors, for easy termination of fiber

Applications

- Industrial control and factory automation
- Optical transmitter and receiver for 10-MBd systems and below
- Serial field buses
- Intra-system links; board-to-board, rack-to-rack
- Extension of RS-232 and RS-485
- High voltage isolation
- Elimination of ground loops
- Reduces voltage transient susceptibility
- Drivers and inverters

Application Literature

Application Note 1035 (Versatile Link), AV02-0730EN.

Package and Handling Information

The compact Versatile Link package is made of a flame retardant material and uses the same pad layout as a standard, eight-pin dual-in-line package. Horizontal packages are available. These low-profile Versatile Link packages are stackable and are enclosed to provide a dust-resistant seal. Snap action simplex, simplex latching, duplex, and duplex latching connectors are offered with simplex or duplex cables.

Package Housing Color

Versatile Link components and simplex connectors are color coded to eliminate confusion when making connections. Receiver packages are black, and transmitters are grey.

Handling

Versatile Link components are auto-insertable. When wave soldering is performed with Versatile Link components, the optical port plug should be left in to prevent contamination of the port. Do not use reflow solder processes (i.e., infrared reflow or vapor-phase reflow). Non-halogenated water soluble fluxes (i.e., 0% chloride), not rosin based fluxes, are recommended for use with Versatile Link components.

Versatile Link components are moisture-sensitive devices and are shipped in a moisture sealed bag. If the components are exposed to air for an extended period of time, they may require a baking step before the soldering process. Refer to the special labeling on the shipping tube for details.

Recommended Chemicals for Cleaning/Degreasing

Alcohols: methyl, isopropyl, isobutyl.

Aliphatics: hexane, heptanes.

Other: soap solution, naphtha.

Do not use partially halogenated hydrocarbons such as 1,1,1 trichloroethane, ketones such as MEK, acetone, chloroform, ethyl acetate, methylene dichloride, phenol, methylene chloride, or N-methylpyrrolidone. Broadcom does not recommend the use of cleaners that use halogenated hydrocarbons because of their potential environmental harm.

Interlocked (Stacked) Assemblies

Refer to [Figure 1](#).

Horizontal packages can be stacked by placing units with pins facing upward. Initially engage the interlocking mechanism by sliding the L bracket body from above into the L slot body of the lower package. Use a straight edge, such as a ruler, to bring all stacked units into uniform alignment. This technique prevents potential harm that could occur to fingers and hands of assemblers from the package pins. Stacked horizontal packages can be disengaged if necessary. Repeated stacking and unstacking causes no damage to individual units.

Figure 1 Interlocked (Stacked) Horizontal Packages

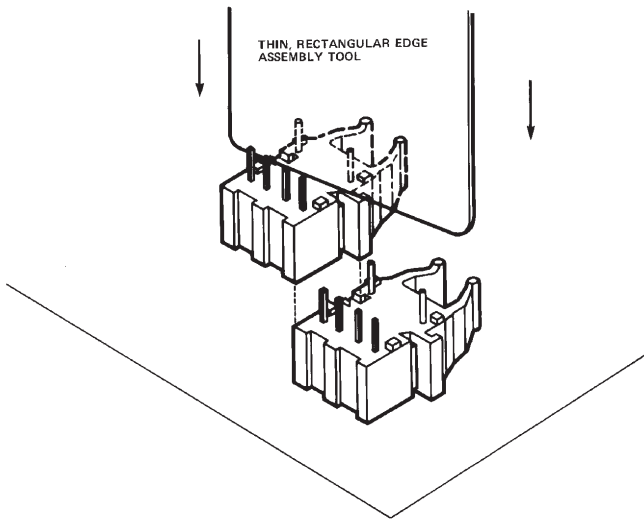

Mechanical Dimensions

Figure 2 Mechanical Dimensions - Horizontal Packages

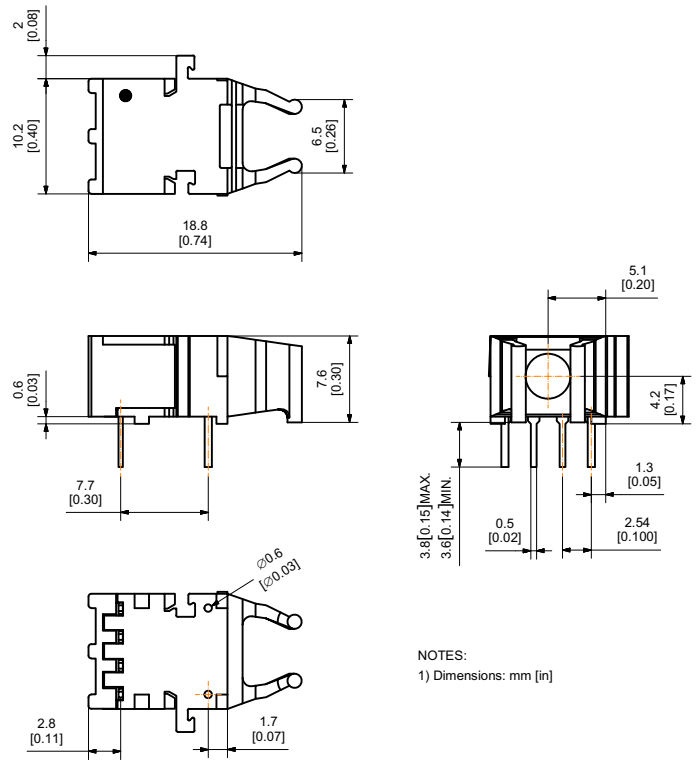

Versatile Link Printed Board Layout Dimensions

Figure 3 PCB Dimensions - Horizontal Packages

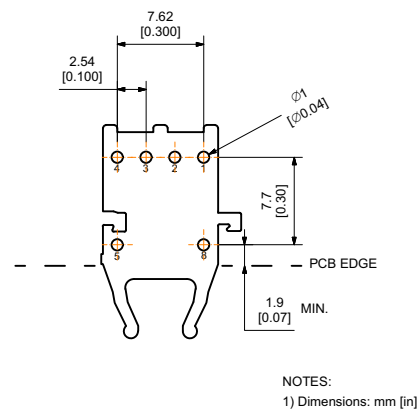

Footprint - TOP VIEW

Regulatory Compliance (AFBR-1528CZ/AFBR-2528CZ)

Feature	Test Method	Performance
Electrostatic Discharge (ESD) to the Electrical Pins Human Body Model	MIL-STD-883 Method 3015	Min ± 2000 V
Eye Safety ^a	IEC 60825-1,2,Class 1	Class 1

a. Valid for optical transmitter AFBR-1528CZ only.

Process Compatibility (AFBR-1528CZ/AFBR-2528CZ)

Parameter	Symbol	Min	Typical	Max	Unit
Solder Environment ^{a, b}	T _{SOLD}	—	—	260 ^c	°C
	t _{SOLD}	—	—	10 ^d	sec

- a. Solder surface to be at least 1.6 mm below lead frame stops.
- b. Product is Moisture Sensitive Level 3.
- c. Maximum temperature refers to peak temperature.
- d. Maximum time refers to time spent at peak temperature.

10-MBd Link Performance (AFBR-1528CZ/AFBR-2528CZ)

The optical link performance for operating temperatures up to +95 °C is guaranteed only with transmitter AFBR-1528CZ (>20 mA forward peak current).

Parameter	Min	Max	Unit	Condition
Link Distance with Extra Low Loss POF Cable ^a	0.1	58	m	-40 °C to +95 °C
Link Distance with 200 µm PCS Cable ^b	0.1	500	m	-40 °C to +95 °C

- a. Plastic Optical Fiber (POF) is AFBR-HUXYYYY or HFBR-EXXYYYY for operating temperatures up to +85 °C. Worst-case fiber attenuation (0.23 dB/m at 650 nm) used for distance calculation.
- b. Plastic-Clad Silica Fiber (PCS). A worst-case attenuation of 12 dB/km (at 650 nm) used for distance calculation.

Pin Description Transmitter AFBR-1528CZ

Fiber port facing front, pins downward, 1 = Rightmost pin to 4 = Leftmost pin.

Pin	Name	Function/Description
1	Anode	LED anode.
2	Cathode	LED cathode.
3	Pin	No function, physical pin available, recommended to signal GND.
4	Pin	No function, physical pin available, recommended to signal GND.
5	Housing Pin ^a	Physical pin available, recommended to chassis GND.
8	Housing Pin ^a	Physical pin available, recommended to chassis GND.

- a. Pins 5 and 8 are for mounting and retaining purposes. Make sure they are electrically connected to Chassis GND.

NOTE This is an inverting circuitry; thus, the LED is off in case of DATA H. Therefore, an inverting receiver, e.g., AFBR-2528CZ, should be used accordingly.

Figure 4 Recommended Drive Circuit

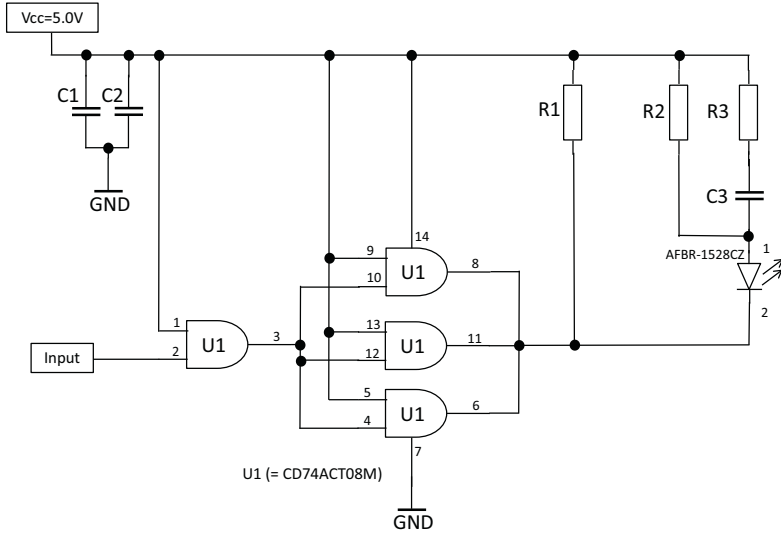

Note: $I_{F,on} = 30 \text{ mA}$ nominal at $T_A = 25 \text{ }^\circ\text{C}$; $V_{CC} = 5.0 \text{ V}$.

	Value	Tolerance
R1	2 k Ω	5%
R2	100 Ω	1%
R3	15 Ω	1%
C1	0.1 μF	20%
C2	10 μF	20%
C3	120 pF	5%

Pin Description Receiver AFBR-2528CZ

Fiber port facing front, pins downward, 1 = Rightmost pin to 4 = Leftmost pin.

Pin	Name	Function/Description
1	Data Out ^{a, b}	Data output.
2	V _{EE}	Ground.
3	V _{CC}	Power Supply 3.3 V ± 5% or 5 V ± 5%.
4	Pin ^c	No function, physical pin is available, recommended to signal GND.
5	Housing Pin ^d	Physical pin is available, recommended to chassis GND.
8	Housing Pin ^d	Physical pin is available, recommended to chassis GND.

- a. TTL compatible data output.
- b. Light on at the receiver input will lead to a "low" output signal and light off to a "high" output signal.
- c. It is recommended to connect this pin to signal GND.
- d. Pin 5 and 8 are for mounting and retaining purposes and should be connected to chassis GND.

Recommended Application Circuit

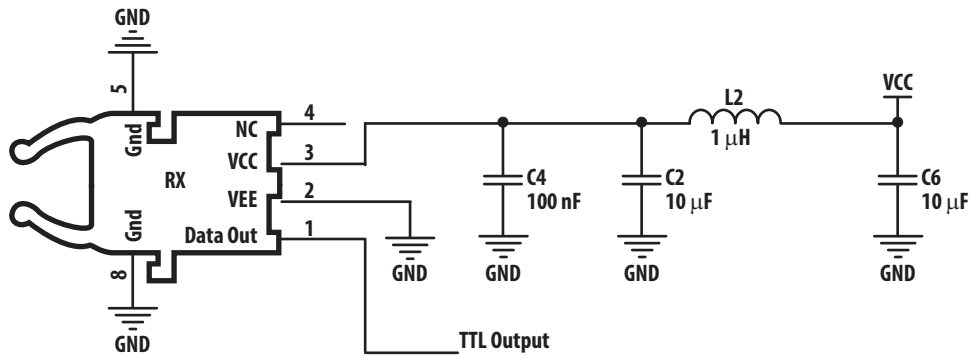

AFBR-1528CZ Analog Transmitter

The AFBR-1528CZ analog transmitter utilizes a 650-nm LED source in a housing designed to efficiently couple into 1-mm Polymer Optical Fiber (POF) or 200- μ m Plastic-Clad Silica (PCS). Links up to 58 meters are supported with 1-mm POF. Links up to 500 meters are supported with 200- μ m PCS.

Absolute Maximum Ratings (AFBR-1528CZ)

Parameter	Symbol	Min	Max	Unit
Storage and Operating Temperature	$T_{S,O}$	-40	95	$^{\circ}\text{C}$
Transmitter Peaking Forward Input Current ^a	$I_{F,PK}$	—	45	mA
Transmitter Short Term Peaking Forward Input Current ^b	$I_{F,PKshort}$	—	80	mA
Transmitter Average Forward Input Current	$I_{F,AVG}$	—	30	mA
Transmitter Reverse Input Voltage	V_R	—	3	V

- For $I_{F,PK} > 30$ mA, the duty factor must maintain ≤ 30 mA $I_{F,AVG}$ and pulse width ≤ 1 μ s.
- Maximum short-term peaking forward current must not longer be applied than 5 ns to improve rise time or enhance signaling rate. Applying a short-term peaking forward current shall not result in exceeding 30 mA average forward current.

Recommended Operating Conditions (AFBR-1528CZ)

Parameter	Symbol	Min	Max	Unit
Ambient Temperature ^{a, b}	T_A	-40	95	$^{\circ}\text{C}$
Transmitter Average Forward Input Current ^a	$I_{F,AVG}$	3	30	mA
Signaling Rate ^{a, c}	f_s	DC	10	MBd

- Recommended operating conditions are those values outside of which functional performance is not intended, device reliability is not implied, and damage to the device may occur over an extended period of time. See Reliability Data Sheet for specific reliability performance.
- Measured at the housing.
- Using driver circuit [Figure 4](#) (without peaking and clamping of the electrical input signal).

Electrical and Optical Characteristics (AFBR-1528CZ)

TA = -40 °C to +95 °C unless otherwise stated.

Parameter	Symbol	Min	Typical	Max	Unit	Conditions	Notes
Peak Output Power, 1 mm POF, 30 mA	P_T	-6	-1	2	dBm	$I_{F,DC} = 30 \text{ mA}$	a, b, c
Peak Output Power, 200 m PCS, 30 mA	P_T	-18	-12	-9	dBm	$I_{F,DC} = 30 \text{ mA}$	a, b, c
Peak Output Power, 1 mm POF, 10 mA	P_T	-11	-6	-3	dBm	$I_{F,DC} = 10 \text{ mA}$	a, b, c
Peak Output Power, 1 mm POF, 5 mA	P_T	-14	-9	-6	dBm	$I_{F,DC} = 5 \text{ mA}$	a, b, c
Peak Output Power, 1 mm POF, 3 mA	P_T	-16	-11	-8	dBm	$I_{F,DC} = 3 \text{ mA}$	a, b, c
Optical Power Temperature Coefficient	$\Delta P_T / \Delta T$	—	-0.01	—	dB/K	-40 °C to +25 °C	c
		—	-0.02	—	dB/K	+25 °C to +95 °C	c
Peak Emission Wavelength	λ_p	630	650	685	nm	—	c
Peak Emission Wavelength Temperature Coefficient	$\Delta \lambda / \Delta T$	—	0.16	—	nm/K	—	c
Spectral Width	FWHM	—	20	—	nm	—	c
Forward Voltage	V_F	1.4	—	2.3	V	$I_{F,DC} = 3 \text{ mA to } 30 \text{ mA}$	
Forward Voltage Temperature Coefficient $I_{F,DC} = 30 \text{ mA}$	$\Delta V_F / \Delta T$	—	-2.8	—	mV/K	-40 °C to +25 °C	c
		—	-1.1	—	mV/K	+25 °C to +95 °C	c
Reverse Input Breakdown Voltage	—	9	20	—	V	—	c
Diode Capacitance	—	—	30	70	pF	—	c
Optical Rise Time (20% to 80%)	t_r	—	3	20	ns	—	c, d
Optical Fall Time (80% to 20%)	t_f	—	3	20	ns	—	c, d

- Optical power measured with polished connector end face at the end of 0.5 meters of 1-mm diameter POF with a numerical aperture (NA) of 0.5, or of 200- μm diameter PCS, with NA = 0.37.
- Minimum average output power specification value includes 1-dB degradation margin.
- Typical values are mean values measured at $T_A = 25 \text{ }^\circ\text{C}$.
- Using drive circuit in [Figure 4](#) for $I_{F,DC} = 30 \text{ mA}$; $V_{CC} = 5.0 \text{ V}$.

Figure 5 Typical Forward Voltage vs. Drive Current

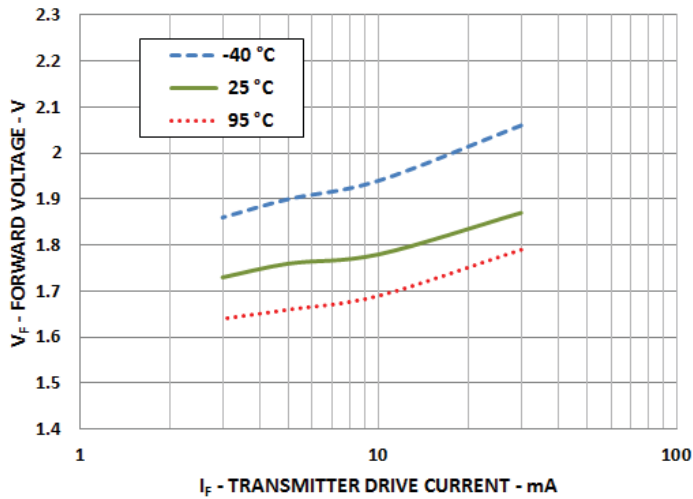
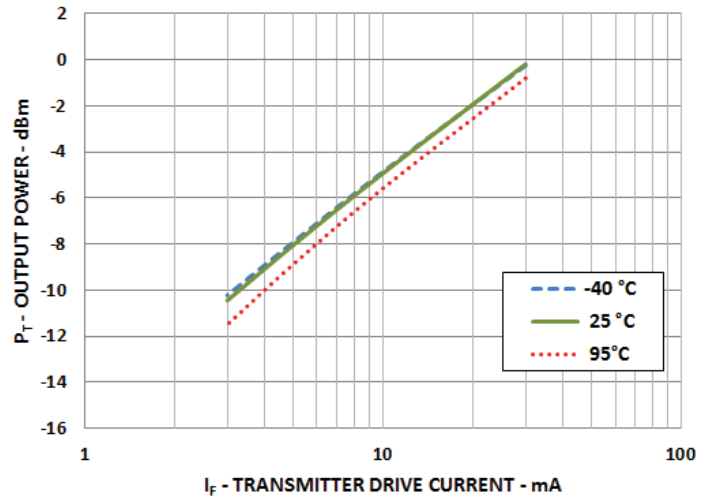

Figure 6 Typical Optical Output Power, 1mm POF vs. Drive Current



AFBR-2528CZ Receiver

The AFBR-2528CZ receiver consists of a digitalizing IC with integrated photodiode to produce an output level that is compatible with TTL logic. The integrated photodiode and the following amplifier use a fully differential approach with an active and a passive area for an improved EMI performance. Within the specified ranges, the AFBR-2528CZ devices support a BER <10E-9.

Absolute Maximum Ratings (AFBR-2528CZ)

Parameter	Symbol	Min	Typ	Max	Unit
Storage and Operating Temperature ^a	T _{S,O}	-40	—	95	°C
Relative Humidity ^a	RH	0	—	85	%
Supply Voltage ^a	V _{CC}	-0.5	—	6	V
Data Output Current ^a	I _O	—	—	10	mA

a. Absolute Maximum Ratings are those values beyond which damage to the device can occur if these limits are exceeded for other than a short period of time.

Recommended Operating Conditions (AFBR-2528CZ)

Parameter	Symbol	Min	Typ	Max	Unit
Ambient Temperature ^{a, b}	T _A	-40	25	95	°C
Supply Voltage ^a	V _{CC}	3.135	3.3	3.465	V
		4.75	5	5.25	V
Data Rate ^a	—	DC	—	10	MBd

a. Recommended operating conditions are those values outside of which functional performance is not intended, device reliability is not implied, and damage to the device may occur over an extended period of time. See Reliability Data Sheet for specific reliability performance.

b. Measured at the housing.

Receiver Electrical Characteristics (AFBR-2528CZ)

$T_A = -40\text{ }^\circ\text{C}$ to $+95\text{ }^\circ\text{C}$, $V_{CC} = 3.3\text{ V} \pm 5\%$ or $5\text{ V} \pm 5\%$.

Parameter	Symbol	Min	Typical	Max	Unit
Supply Current ^a	I_{CC}	—	6	10	mA
Data Output Voltage – Low ^b	V_{OL}	-0.3	—	0.4	V
Data Output Voltage – High ^b	V_{OH}	2.5	—	$V_{CC} + 0.3$	V
Rise Time (10% to 90%) ^c	t_R	—	—	10	ns
Fall Time (90% to 10%) ^c	t_F	—	—	10	ns
Pulse Width Distortion ^{c, d, e, f}	PWD	-30	—	30	ns
Propagation Delay ^{c, d}	t_D	—	—	60	ns
Propagation Skew ^{c, d, g}	t_{skew}	—	—	20	ns
V_{CC} Level to Deactivate POR ^{a, h}	V_{POR_DEACT}	—	2.8	—	V
V_{CC} Level to Activate POR ^{a, h}	V_{POR_ACT}	—	2.6	—	V
POR Deactivate Delay Time ^{a, h}	$t_{POR_DEACT_DEL}$	—	100	—	μs

- Typical values are mean values measured at $T_A = 25\text{ }^\circ\text{C}$ and 5 V.
- Standard TTL output.
- Measured with $R_L = 5\text{ k}\Omega$ and $C_L = 20\text{ pF}$.
- Guaranteed only if optical input signal is generated by AFBR-1528CZ, with ideal alignment to the photodiode using a 1 mm POF (NA = 0.5).
- Optical input of 10Mbaud PRBS-7 pattern and 50% duty cycle. Optical input rise time (10% to 90%) $\leq 20\text{ ns}$, optical input fall time (90% to 10%) $\leq 20\text{ ns}$.
- Pulse width is measured at 50% threshold using a rising edge trigger and PRBS-7 pattern.
- Only valid for same input signal characteristics and environmental conditions. Optical input power has to be $\geq -21\text{ dBm}$ (Peak).
- Power-on reset (POR) is active below V_{POR_DEACT} . Once V_{POR_DEACT} is reached, the POR remains active for $t_{POR_DEACT_DEL}$. During power down, POR starts at V_{POR_ACT} . Refer to [Figure 7](#).

Receiver Optical Characteristics (AFBR-2528CZ)

$T_A = -40\text{ }^\circ\text{C}$ to $+95\text{ }^\circ\text{C}$, $V_{CC} = 3.3\text{ V} \pm 5\%$ or $5\text{ V} \pm 5\%$.

Parameter	Symbol	Min	Typical	Max	Unit
Input Optical Power POF (Peak) ^a	P_{IN}	-24	—	1	dBm
Input Optical Power PCS (Peak) ^b	P_{IN}	-26	—	-2	dBm
Input Optical Power Off-State POF ^a	P_{IN_Off}	-40	—	—	dBm
Input Optical Power Off-State PCS ^b	P_{IN_Off}	-43	—	—	dBm
Optical Spectrum Range	λ	630	—	685	nm

- Measured at the end of a 0.5 m POF (1 mm, 0.5 NA) with a large area optical detector.
- Measured at the end of a 0.5 m PCS (200 μm , 0.37 NA) with a large area optical detector.

Power-on Reset (POR) Functionality

Figure 7 Typical Functionality of Power-on Reset (POR)

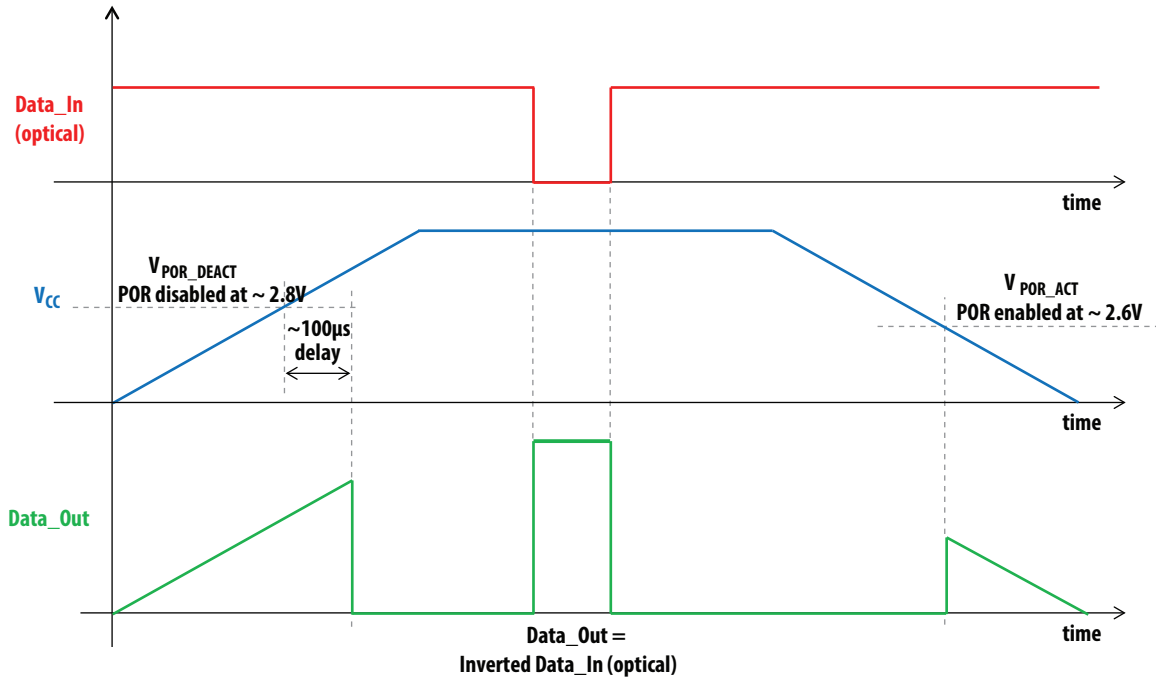

For product information and a complete list of distributors, please go to our web site: www.broadcom.com.

Broadcom, the pulse logo, Connecting everything, Avago Technologies, Avago, and the A logo are among the trademarks of Broadcom in the United States, certain other countries and/or the EU.

Copyright © 2016 Broadcom. All Rights Reserved.

The term "Broadcom" refers to Broadcom Limited and/or its subsidiaries. For more information, please visit www.broadcom.com.

Broadcom reserves the right to make changes without further notice to any products or data herein to improve reliability, function, or design.

Information furnished by Broadcom is believed to be accurate and reliable. However, Broadcom does not assume any liability arising out of the application or use of this information, nor the application or use of any product or circuit described herein, neither does it convey any license under its patent rights nor the rights of others.

pub-005757 – October 3, 2016

