



Chipsmall Limited consists of a professional team with an average of over 10 year of expertise in the distribution of electronic components. Based in Hongkong, we have already established firm and mutual-benefit business relationships with customers from,Europe,America and south Asia,supplying obsolete and hard-to-find components to meet their specific needs.

With the principle of “Quality Parts,Customers Priority,Honest Operation,and Considerate Service”,our business mainly focus on the distribution of electronic components. Line cards we deal with include Microchip,ALPS,ROHM,Xilinx,Pulse,ON,Everlight and Freescale. Main products comprise IC,Modules,Potentiometer,IC Socket,Relay,Connector.Our parts cover such applications as commercial,industrial, and automotives areas.

We are looking forward to setting up business relationship with you and hope to provide you with the best service and solution. Let us make a better world for our industry!



## Contact us

Tel: +86-755-8981 8866 Fax: +86-755-8427 6832

Email & Skype: info@chipsmall.com Web: www.chipsmall.com

Address: A1208, Overseas Decoration Building, #122 Zhenhua RD., Futian, Shenzhen, China



# AFBR-59R5LZ

Digital Diagnostic 2x7 SFF 850 nm 4.25/2.125/1.0625 GBd,  
RoHS-Compliant Optical Transceiver



## Data Sheet

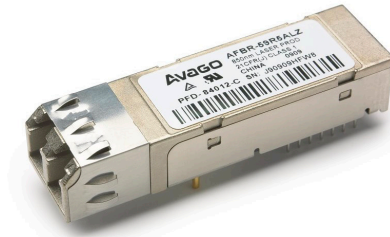

### Description

Avago Technologies' AFBR-59R5LZ optical transceiver supports high-speed serial links over multimode optical fiber at signaling rates up to 4.25 GBd. Compliant with the Small Form Factor (SFF) Multi Source Agreement (MSA) 2x5/2x10 mechanical specifications for LC Duplex transceivers, ANSI Fibre Channel FC-PI and IEEE 802.3 for gigabit applications the part is electrically interoperable with 2x5 and 2x6 conformant devices. The AFBR-59R5LZ is dimensionally compliant with the SFF MSA form factor with the exception of two additional pins for communicating with the diagnostic interface.

As an enhancement to the conventional SFF 2x5 interface defined in the SFF MSA (Multi-Source Agreement), the AFBR-59R5LZ is compliant to SFF-8472 (digital diagnostic interface for optical transceivers). Using the 2-wire serial interface defined in the SFF-8472 MSA, the AFBR-59R5LZ provides real time temperature, supply voltage, laser bias current, laser average output power and received average input power.

This information is in addition to conventional SFP/GBIC base data. The digital diagnostic interface also adds the ability to disable the transmitter (TX\_DISABLE), monitor for Transmitter Faults (TX\_FAULT) and monitor for Receiver Signal Detect (Sig\_Det). This 2x7 package also includes one dedicated 'hard' pin for TX\_FAULT.

### Application

- Fibre Channel and iSCSI HBA Cards

### Related Products

- AFBR-57R5APZ: 850 nm +3.3 V LC SFP for 4.25/2.125/1.0625 GBd Fibre Channel

### Features

- Fully RoHS Compliant
- Diagnostic Features Per SFF-8472 "Diagnostic Monitoring Interface for Optical Transceivers"
- Real time monitoring of:
  - Transmitted Optical Power
  - Received Optical Power
  - Laser Bias Current
  - Temperature
  - Supply Voltage
- Wide Temp and supply voltage operation (-10°C to 85°C) (3.3 +/- 10%)
- Transceiver Specifications per SFF 2x5 Multi-Source Agreement and SFF-8472 (revision 9.3)
  - 4.25 GBd Fibre Channel operation for FC-PI 400-M5-SN-I and 400-M6-SN-I
  - 2.125 GBd Fibre Channel operation for FC-PI 200-M5-SN-1 and 200-M6-SN-I
  - 1.0625 GBd Fibre Channel operation for FC-PI 100-M5-SN-I and 100-M6-SN-I
- Link Lengths at 4.25 Gbd:
  - 150 m with 50 um MMF, 70 m with 62.5 um MMF
- Link Lengths at 2.125 Gbd
  - 300m with 50um MMF, 150m with 65.5um MMF
- Link Lengths at 1.0625 Gbd:
  - 500 m with 50 µm MMF, 300 m with 62.5 µm MMF
- LC Duplex optical connector interface conforming to ANSI TIA/EIA604-10 (FOCIS 10A)
- 850nm Vertical Cavity Surface Emitting Laser (VCSEL) Source Technology
- IEC 60825-1 Class 1/CDRH Class 1 laser eye safe
- Compatible with Gigabit Ethernet

## Digital Diagnostic Interface and Serial Identification

The 2-wire serial interface is based on ATMEL AT24C01A series EEPROM protocol and signaling detail. Conventional EEPROM memory, bytes 0-255 at memory address 0xA0, is organized in compliance with SFF-8074i. New digital diagnostic information, bytes 0-255 at memory address 0xA2, is compliant to SFF-8472. The new diagnostic information provides the opportunity for Predictive Failure Identification, Compliance Prediction, Fault Isolation and Component Monitoring.

The I2C accessible memory page address 0xB0 is used internally by SFP for the test and diagnostic purposes and it is reserved.

## Predictive Failure Identification

The predictive failure feature allows a host to identify potential link problems before system performance is impacted. Prior identification of link problems enables a host to service an application via “fail over” to a redundant link or replace a suspect device, maintaining system uptime in the process. For applications where ultra-high system uptime is required, a digital SFF provides a means to monitor two real-time laser metrics associated with observing laser degradation and predicting failure: average laser bias current (Tx\_Bias) and average laser optical power (Tx\_Power).

## Compliance Prediction:

Compliance prediction is the ability to determine if an optical transceiver is operating within its operating and environmental requirements. AFBR-59R5LZ devices provide real-time access to transceiver internal supply voltage and temperature, allowing a host to identify potential component compliance issues. Received optical power is also available to assess compliance of a cable plant and remote transmitter. When operating out of requirements, the link cannot guarantee error free transmission.

## Fault Isolation

The fault isolation feature allows a host to quickly pinpoint the location of a link failure, minimizing system downtime. For optical links, the ability to identify a fault at a local device, remote device or cable plant is crucial to speeding service of an installation. AFBR-59R5LZ real-time monitors of Tx\_Bias, Tx\_Power, Vcc, Temp and Rx average power can be used to assess local transceiver current operating conditions. In addition, status flags Tx Disable and Rx Signal Detect are mirrored in memory and available via the two-wire serial interface.

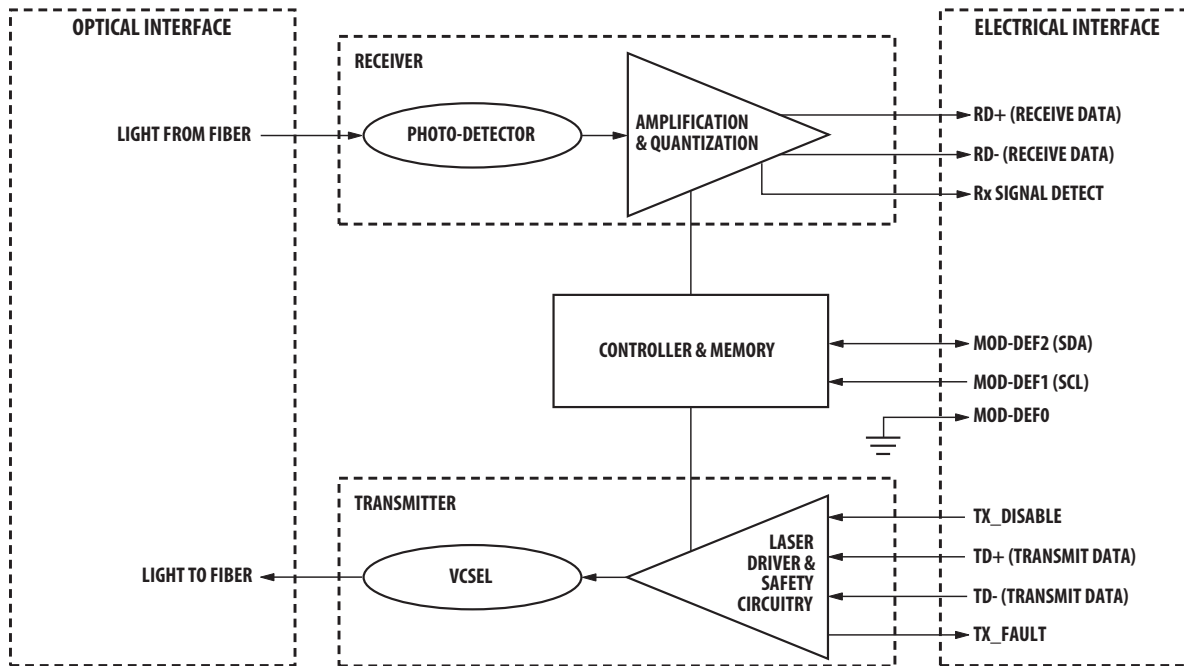

Figure 1. Transceiver Functional Diagram

## Component Monitoring

The AFBR-59R5LZ real-time monitors of Tx\_Bias, Tx\_Power, Vcc, Temp and Rx Average Power may potentially be used as a debugging aid for system installation and design, and transceiver parametric evaluation for factory or field qualification. For example, temperature per module can be observed in high-density applications to facilitate thermal evaluation of blades and systems.

## Transmitter Section

The transmitter section contains 850nm VCSEL (Vertical Cavity Surface Emitting Laser) light source, located at the optical interface which mates with the LC optical connector. The VCSEL is driven by a custom IC which uses the incoming differential (PECL compatible) high speed logic signal to modulate laser diode driver current. This Tx laser driver circuit regulates optical output power at a constant level provided the incoming data pattern is dc balanced (8B/10B code, for example).

## Transmit Disable (Tx\_Disable)

The AFBR-59R5LZ accepts a TTL transmit disable control signal input which shuts down the transmitter. A high signal implements this function while a low signal allows normal transceiver operation. In the event of a fault (e.g. eye safety circuit activated), cycling this control signal resets the module as depicted in Figure 5. An internal pull down resistor enables the laser if the line is not connected on the host board. Host systems should allow a 10ms interval between successive assertions of this control signal. Tx\_Disable can be asserted via the two-wire serial interface (address A2h, byte 110, bit 6) and monitored (address A2h, byte 110, bit 7).

The contents of A2h, byte 110 bit 6 are logic Or'd with the TX\_DISABLE pin to control the transmit output.

## Eye Safety Circuit

The AFBR-59R5LZ provides Class 1 (single fault tolerant) eye safety by design and has been tested for compliance with the requirements listed in Table 1. The eye safety circuit continuously monitors optical output power levels and will disable the transmitter upon detecting an unsafe condition beyond the scope of Class 1 certification. Such unsafe conditions can be due to inputs from the host board (Vcc fluctuation, unbalanced code) or a fault within the transceiver.

## Receiver Section

The receiver section contains a PIN photodiode and custom transimpedance preamplifier, located at the optical interface which mates with the LC optical connector. The output is fed to a custom IC that provides post-amplification and quantization.

## Signal Detect (Sig\_Det)

The post-amplification IC also includes the transition detection circuitry which monitors the ac level of incoming optical signals and provides a TTL status signal to the host. An adequate optical input results in high signal detect output while a low signal detect output indicates an unusable optical input. The signal detect thresholds are set so that a low output indicates a definite optical fault has occurred. Signal Detect can be monitored via the two-wire serial (address A2h, byte 110, bit 1).

## Functional Data I/O

The AFBR-59R5LZ interfaces with the host circuit board through fourteen I/O pins (2x7) identified by function in Table 2. These pins are sized for the use in boards between 0.062 in. and 0.100 in. thick. The board layout for this interface is depicted in Figure 7.

The AFBR-59R5LZ transmit and receive interfaces are PECL compatible. To simplify board requirements, transmitter bias resistors and ac coupling capacitors are incorporated into the transceiver module and so are not required on the host board. The Tx\_Disable and Signal Detect lines require TTL lines on the host board if they are to be utilized. The transceiver will operate normally if these lines are not connected on the host board.

Figure 2 depicts the recommended interface circuit to link the AFBR-59R5LZ to the supporting physical layer ICs. Timing for MSA compliant control signals implemented in the transceiver are listed on Page 12 and diagramed in Figure 5.

## PCB Assembly Process Compatibility

The AFBR-59R5LZ is compatible with industry standard wave solder and aqueous wash processes as detailed on Page 13. The transceiver is shipped with a process plug to keep out impinging liquids, but is not intended to be immersed. After assembly, the process plug should be kept in place as a dust plug when the transceiver is not in use.

## Caution

There are no user serviceable parts nor maintenance requirements for the AFBR-59R5LZ. All mechanical adjustments are made at the factory before shipping. Tampering with, modifying, misusing or improperly handling the AFBR-59R5LZ will void the product warranty. It may also result in improper operation and possibly overstress the laser source. Performance degradation or device failure may result. Connection of the AFBR-59R5LZ to a light source not compliant to IEEE 802.3 or ANSI FC-PI specifications, operating above the maximum operating conditions or in a manner inconsistent with its design and function may result in exposure to hazardous light radiation and may constitute an act of modifying or manufacturing a laser product.

Persons performing such an act are required by law to re-certify and re-identify the laser product under the provisions of U.S. 21 CFR (Subchapter J) and the TUV.

## Ordering Information

Please contact your local field sales engineer or one of Avago Technologies franchised distributors for ordering information. For technical information, please visit Avago Technologies' WEB page at [www.avagotech.com](http://www.avagotech.com) or contact Avago Technologies Customer Response Center at 1-800-235-0312. For information related to SFF Committee documentation visit [www.sffcommittee.org](http://www.sffcommittee.org)

## Regulatory Compliance

The AFBR-59R5LZ complies with all applicable laws and regulations as detailed in Table 1. Certification level is dependent on the overall configuration of the host equipment. The transceiver performance is offered as a figure of merit to assist the designer.

### Electrostatic Discharge (ESD)

The AFBR-59R5LZ is compatible with ESD levels found in typical manufacturing and operating environments as described in Table 1. In the normal handling and operation of optical transceivers, ESD is of concern in two circumstances.

The first case is during handling of the transceiver prior to soldering onto the host board. To protect the device, it's important to use normal ESD handling precautions. These include using grounded wrist straps, workbenches and floor mats wherever the transceiver is handled.

The second case to consider is static discharges to the exterior of the host equipment chassis after assembly.

If the optical interface is exposed to the exterior of host equipment cabinet, the transceiver may be subject to system level ESD requirements.

### Electromagnetic Interference (EMI)

Equipment incorporating gigabit transceivers is typically subject to regulation by the FCC in the United States, TUV and CENELEC EN55022 (CISPR 22) in the European Union and VCCI in Japan. The AFBR-59R5LZ's compliance to these standards is detailed in Table 1. The metal housing and shielded design of the AFBR-59R5LZ minimize the EMI challenge facing the equipment designer.

### Flammability

The AFBR-59R5LZ optical transceiver is made of metal and high strength, heat resistant, chemical resistant and UL 94V-0 flame retardant plastic.

### EMI Immunity

Due to its shielded design, the EMI immunity of the AFBR-59R5LZ exceeds typical industry standards.

**Table 1. Regulatory Compliance**

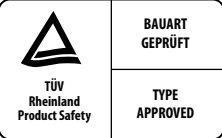
| Feature   | Test Method   | Performance  |
|---|---|--|
| Electrostatic Discharge (ESD) to the Electrical Pins                                | MIL-STD-883C Method 3015.4  | Class 1 (> 2000 Volts)   |
| Electrostatic Discharge (ESD) to the Duplex LC Receptacle                           | Variation of IEC 61000-4-2  | Typically withstands at least 15 kV without damage when the duplex LC connector receptacle is contacted by a Human Body Model probe. Fulfills Live Traffic ESD testing up to 8 kV with less than 1 errored second. |
| Electromagnetic Interference (EMI)  | FCC Class B<br>CENELEC EN55022 Class B (CISPR 22A)<br>VCCI Class 1  | System margins are dependent on customer board and chassis design.   |
| Immunity  | Variation of IEC 61000-4-3  | Typically shows no measurable effect from a 10 V/m field swept from 10 MHz to 1 GHz applied to the transceiver without a chassis enclosure   |
| Laser Eye Safety and Equipment Type Testing   | US FDA CDRH AEL Class 1<br>US21 CFR, Subchapter J per Paragraphs 1002.10 and 1002.12.<br><br>(IEC) EN60825-1: 2007<br>(IEC) EN60825-2: 2004+A1<br>(IEC) EN60950-1: 2006+A11 | CDRH certification #9720151-57<br>TUV file #R72102088.01   |
|  |   |  |
| Component Recognition   | Underwriters Laboratories and Canadian Standards Association Joint Component Recognition for Information Technology Equipment Including Electrical Business Equipment       | UL File # E173874<br>Must comply with UL1950 or CUL 1950.  |
| RoHS Compliance   |   | Less than 1000ppm of cadmium, lead, mercury, hexavalent chromium, polybrominated biphenyls, and polybrominated diphenyl ethers   |

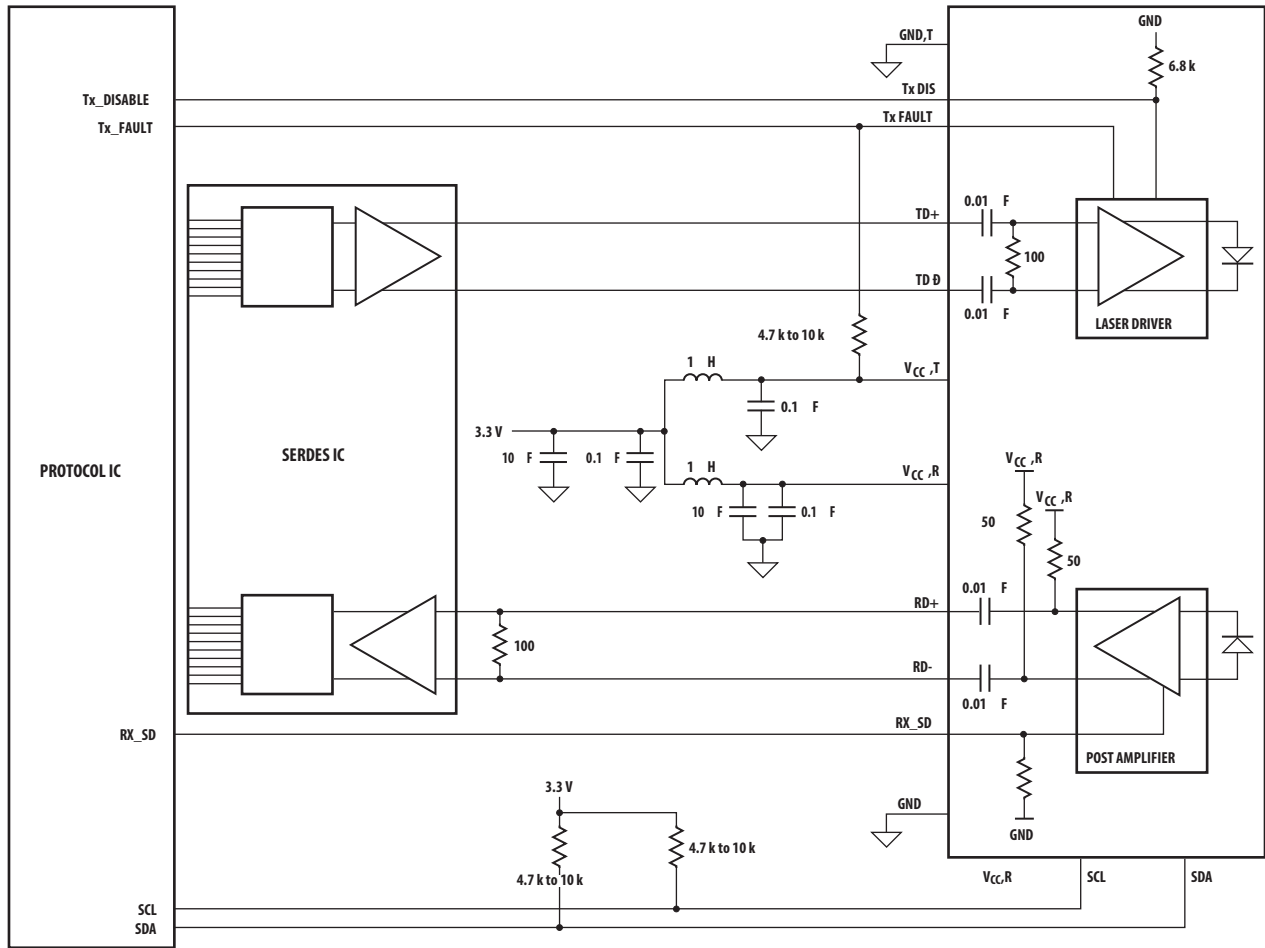
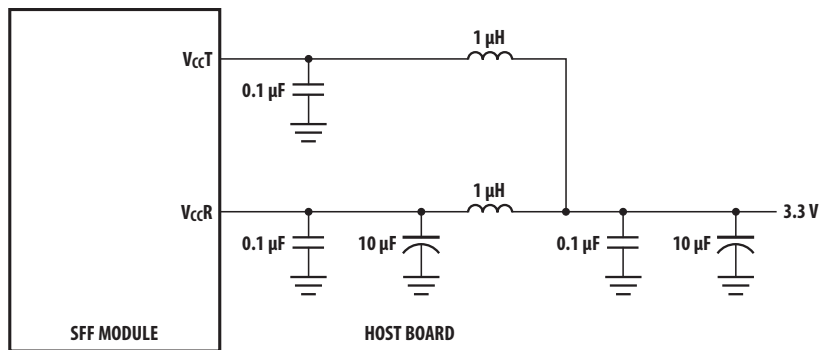

Figure 2. Typical Application Configuration



NOTE: INDUCTORS MUST HAVE LESS THAN 1 W SERIES RESISTANCE TO LIMIT VOLTAGE DROP TO THE SFF MODULE.

Figure 3. Recommended Power Supply Filter

**Table 2. Pin Description**

| Pin | Name              | Function/Description  | Notes |
|-----|-------------------|---|-------|
| 1   | V <sub>EE</sub> R | Receiver Signal Ground  | 7     |
| 2   | V <sub>CC</sub> R | Receiver Power Supply: +3.3V                                    | 5     |
| 3   | SD                | TTL Signal Detect: Active High                                  | 3     |
| 4   | RD-               | Received Data Out Bar   | 4     |
| 5   | RD+               | Received Data Out   | 4     |
| 6   | V <sub>CC</sub> T | Transmitter Power Supply: +3.3V                                 | 5     |
| 7   | V <sub>EE</sub> T | Transmitter Signal Ground                                       | 7     |
| 8   | TX_DISABLE        | TTL Transmitter Disable: Active High, (Open = Enabled)          | 1     |
| 9   | TD+               | Transmitter Data In   | 6     |
| 10  | TD-               | Transmitter Data In Bar   | 6     |
| A   | SDA               | Serial Interface Data I/O (Mod-def2)                            | 2     |
| B   | SCL               | Serial Interface Clock Input (Mod-def1)                         | 2     |
| C   | NC                |   |       |
| D   | TX_FAULT          | Transmitter Fault Indication - High Indicates a fault condition | 8     |

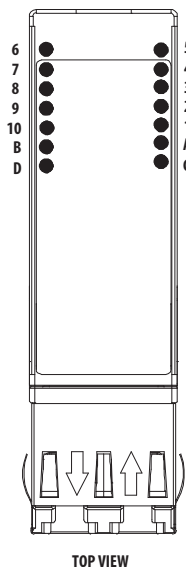

**Figure 4. Module pin configuration.**

**Notes:**

- TX\_DISABLE is an input that is used to shut down the transmitter optical output. It is pulled down with 6.8 k $\Omega$  internal to the transceiver.  
 Low (0 – 0.8 V) or Open: Transmitter Enabled  
 Between (0.8 V and 2.0 V): Undefined  
 High (2.0 – V<sub>CC</sub> max): Transmitter Disabled  
 The TX\_DISABLE pin state is logic Or'd with the contents of EEPROM address A2h, byte 110 bit 6 (soft disable control bit) to control the transmit output.
- The signals SDA and SCL designate the two wire serial interface pins. They must be pulled up with a 4.7 k – 10 k $\Omega$  resistor on the host board. SCL is the serial clock line of two wire serial interface. SDA is the serial data line of two wire serial interface
- Signal Detect is a normally high LVTTTL output. When high it indicates the received optical power is adequate for normal operation. When Low, it indicates the received optical power is insufficient to guarantee error free operation. In the low state, the output will be pulled to < 0.8 V.
- RD-/+ designate the differential receiver outputs. They are ac coupled 100  $\Omega$  differential lines which should be terminated with 100  $\Omega$  differential at the host SerDes input. AC coupling is done inside the transceiver and is not required on the host board. The voltage swing on these lines will be between 600 and 1600 mV differential (300 – 800 mV single ended) when properly terminated.
- V<sub>CC</sub>R and V<sub>CC</sub>T are the receiver and transmitter power supplies. They are defined at the transceiver pins.
- TD-/+ designate the differential transmitter inputs. They are ac coupled differential lines with 100  $\Omega$  differential termination inside the module. The ac coupling is done inside the module and is not required on the host board. The inputs will accept differential swings of 400 – 2400 mV (200 – 1200 mV single ended), though it is recommended that values between 500 and 1200 mV differential (250 – 600 mV single ended) be used for best EMI performance.
- Transmitter and Receiver Ground are common internally on the transceiver PCB. They are electrically connected to signal ground within the transceiver.
- TX\_FAULT is an open collector/drain output, which must be pulled up with a 4.7k – 10k $\Omega$  resistor on the host board. When high, this output indicates a laser fault of some kind. Low indicates normal operation. In the low state, the output will be pulled to < 0.8V.



**Table 3. Absolute Maximum Ratings**

| Parameter                                  | Symbol               | Minimum | Maximum               | Unit | Notes   |
|--|----------------------|---------|-----------------------|------|---------|
| Storage Temperature                        | T <sub>S</sub>       | -40     | +100                  | °C   | 1, 2    |
| Case Operating Temperature                 | T <sub>C</sub>       | -40     | +100                  | °C   | 1, 2    |
| Aqueous Wash Pressure                      |                      |         | 110                   | psi  |         |
| Maximum Wave or Flow Soldering Temperature | T <sub>F</sub>       |         | +260                  | °C   | 4       |
| Relative Humidity, non condensing          | RH                   | 5       | 95                    | %    | 1       |
| Supply Voltage                             | V <sub>CC</sub> T, R | -0.5    | 3.8                   | V    | 1, 2, 3 |
| Voltage to any pin                         |                      | -0.5    | 3.8                   | V    |         |
| Low Speed Input Voltage                    | V <sub>IN</sub>      | -0.5    | V <sub>CC</sub> + 0.5 | V    | 1       |

**Table 4. Recommended Operating Conditions**

| Parameter                  | Symbol               | Minimum | Maximum | Unit | Notes |
|----------------------------|----------------------|---------|---------|------|-------|
| Case Operating Temperature | T <sub>C</sub>       | -10     | +85     | °C   | 5, 6  |
| Supply Voltage             | V <sub>CC</sub> T, R | 2.97    | 3.63    | V    | 6, 7  |
| Data Rate                  |                      | 1.0625  | 4.25    | Gb/s | 6     |

**Table 5. Transceiver Electrical Characteristics**(T<sub>C</sub> = -10°C to +85°C, V<sub>CC</sub>T, V<sub>CC</sub>R = 3.3 V ± 10%)

| Parameter                                   | Symbol                             | Minimum | Maximum                           | Unit   | Notes   |
|---|------------------------------------|---------|-----------------------------------|--------|---------|
| <b>AC Electrical Characteristics</b>        |                                    |         |                                   |        |         |
| Power Supply Noise Rejection (Peak-to-Peak) | PSNR                               | 100     |                                   | mV     | 6       |
| <b>DC Electrical Characteristics</b>        |                                    |         |                                   |        |         |
| Module Supply Current                       | I <sub>CC</sub>                    |         | 210                               | mA     | TX + RX |
| Power Dissipation                           | P <sub>DISS</sub>                  |         | 765                               | mW     |         |
| <b>Low Speed Outputs:</b>                   |                                    |         |                                   |        |         |
| Signal Detect [SD], SDA                     | V <sub>OH</sub><br>V <sub>OL</sub> | 2.0     | V <sub>CC</sub> T, R + 0.3<br>0.8 | V<br>V |         |
| <b>Low Speed Inputs:</b>                    |                                    |         |                                   |        |         |
| Transmitter Disable [TX_DIS], SCL, SDA      | V <sub>IH</sub><br>V <sub>IL</sub> | 2.00    | V <sub>CC</sub><br>0.8            | V<br>V | 7       |

**Notes:**

1. Absolute Maximum Ratings are those values beyond which damage to the device may occur if these limits are exceeded for other than a short period of time. See Reliability Data Sheet for specific reliability performance.
2. Between Absolute Maximum Ratings and the Recommended Operating Conditions functional performance is not intended, device reliability is not implied, and damage to the device may occur over an extended period of time.
3. The module supply voltages, V<sub>CC</sub>T and V<sub>CC</sub>R must not differ by more than 0.5 V or damage to the device may occur.
4. Maximum wave or flow soldering temperature should not be applied for more than 10 seconds.
5. Recommended Operating Conditions are those values for which functional performance and device reliability is implied.
6. Filter per SFF specification is required on host board to remove 10 Hz to 4 MHz content.
7. SCL and SDA are to be pulled up externally with a 4.7 k – 10 kΩ resistor on the host board to 3.3 V.

**Table 6. Transmitter and Receiver Electrical Characteristics** $(T_C = -10^{\circ}\text{C to } +85^{\circ}\text{C}, V_{CC1}, V_{CC2} = 3.3\text{V} \pm 10\%)$ 

| Parameter  | Symbol | Minimum | Maximum      | Unit     | Notes |
|--|--------|---------|--------------|----------|-------|
| <b>High Speed Data Input:</b><br>Transmitter Differential Input Voltage (TD +/-) | $V_I$  | 400     | 2400         | mV       | 1     |
| <b>High Speed Data Output:</b><br>Receiver Differential Output Voltage (RD +/-)  | $V_O$  | 600     | 1600         | mV       | 2     |
| Receiver Contributed Total Jitter<br>(4.25 Gb/s)                                 | TJ     |         | 0.26<br>62   | UI<br>ps | 4     |
| Receiver Contributed Total Jitter<br>(2.125 Gb/s)                                | TJ     |         | 0.262<br>123 | UI<br>ps | 4     |
| Receiver Contributed Total Jitter<br>(1.0625 Gb/s)                               | TJ     |         | 0.218<br>205 | UI<br>ps | 4     |
| Receiver Electrical Output Rise & Fall Times<br>(20-80%)                         | tr, tf | 50      | 150          | ps       | 5     |

**Notes:**

1. Internally ac coupled and terminated (100 Ohm differential).
2. Internally ac coupled but requires an external load termination (100 Ohm differential).
3. Contributed DJ is measured on an oscilloscope in average mode with 50% threshold and K28.5 pattern
4. Contributed TJ is the sum of contributed RJ and contributed DJ. Contributed RJ is calculated for  $1 \times 10^{-12}$  BER by multiplying the RMS jitter (measured on a single rise or fall edge) from the oscilloscope by 14. Per FC-PI (Table 13 - MM jitter output, note 1), the actual contributed RJ is allowed to increase above its limit if the actual contributed DJ decreases below its limits, as long as the component output DJ and TJ remain within their specified FC-PI maximum limits with the worst case specified component jitter input.
5. 20%-80% electrical rise & fall times measured with a 500 MHz signal utilizing a 1010 data pattern.

**Table 7. Transmitter Optical Characteristics** $(T_C = -10^{\circ}\text{C to } +85^{\circ}\text{C}, V_{CC1}, V_{CC2} = 3.3\text{V} \pm 10\%)$ 

| Parameter  | Symbol                | Minimum | Maximum | Unit          | Notes |
|--|-----------------------|---------|---------|---------------|-------|
| Modulated Optical Output Power (OMA)<br>(Peak-to-Peak) 4.25 Gb/s   | OMA                   | 247     |         | $\mu\text{W}$ | 8     |
| Modulated Optical Output Power (OMA)<br>(Peak-to-Peak) 2.125 Gb/s  | OMA                   | 196     |         | $\mu\text{W}$ | 3     |
| Modulated Optical Output Power (OMA)<br>(Peak-to-Peak) 1.0625 Gb/s | OMA                   | 156     |         | $\mu\text{W}$ | 4     |
| Average Optical Output Power                                       | Pout                  | -9.0    |         | dBm           | 1, 2  |
| Center Wavelength  | $\lambda_C$           | 830     | 860     | nm            |       |
| Spectral Width - rms   | $\sigma_{\text{rms}}$ |         | 0.85    | nm            |       |
| Optical Rise/Fall Time   | tr, tf                |         | 90      | ps            | 7     |
| RIN <sub>12</sub> (OMA)  | RIN                   |         | -118    | dB/Hz         |       |
| Transmitter Contributed Total Jitter (4.25 Gb/s)                   | TJ                    |         | 0.25    | UI            | 6     |
|  |                       |         | 60      | ps            |       |
| Transmitter Contributed Total Jitter (2.125 Gb/s)                  | TJ                    |         | 0.254   | UI            | 6     |
|  |                       |         | 120     | ps            |       |
| Transmitter Contributed Total Jitter (1.0625 Gb/s)                 | TJ                    |         | 0.267   | UI            | 6     |
|  |                       |         | 251     | ps            |       |
| Pout TX_DISABLE Asserted   | P <sub>OFF</sub>      |         | -35     | dBm           |       |

**Notes:**

1. Max Pout is the lesser of Class 1 safety limits (CDRH and EN 60825) or receiver power max.
2. Into 50/125  $\mu\text{m}$  (0.2 NA) and 62.5/125  $\mu\text{m}$  (0.275 NA) multimode optical fiber.
3. An OMA of 196 is approximately equal to an average power of -9 dBm assuming an Extinction Ratio of 9 dB.
4. An OMA of 156 is approximately equal to an average power of -10 dBm assuming an Extinction Ratio of 9 dB.
5. Contributed DJ is measured on an oscilloscope in average mode with 50% threshold and K28.5 pattern.
6. Contributed TJ is the sum of contributed RJ and contributed DJ. Contributed RJ is calculated for  $1 \times 10^{-12}$  BER by multiplying the RMS jitter (measured on a single rise or fall edge) from the oscilloscope by 14. Per FC-PI (Table 13 - MM jitter output, note 1), the actual contributed RJ is allowed to increase above its limit if the actual contributed DJ decreases below its limits, as long as the component output DJ and TJ remain within their specified FC-PI maximum limits with the worst case specified component jitter input.
7. Measured 20-80%.
8. An OMA of 247  $\mu\text{W}$  is approximately equal to an average power of -8 dBm, avg assuming an Extinction Ratio of 9 dB.

**Table 8. Receiver Optical Characteristics** $(T_C = -10^\circ\text{C to } +85^\circ\text{C}, V_{CC1}, V_{CC2} = 3.3\text{V} \pm 10\%)$ 

| Parameter   | Symbol      | Minimum | Maximum | Unit                | Notes                           |
|---|-------------|---------|---------|---------------------|---------------------------------|
| Input Optical Power [Overdrive]                         | $P_{IN}$    |         | 0       | dBm, avg            |                                 |
| Input Optical Modulation Amplitude (p-p)<br>4.25 Gb/s   | OMA         | 61      |         | $\mu\text{W}$ , OMA | 6, 7                            |
| Input Optical Modulation Amplitude (p-p)<br>2.125 Gb/s  | OMA         | 49      |         | $\mu\text{W}$ , OMA | 1, 6                            |
| Input Optical Modulation Amplitude (p-p)<br>1.0625 Gb/s | OMA         | 31      |         | $\mu\text{W}$ , OMA | 2, 6                            |
| Stressed receiver sensitivity (OMA)<br>4.25 Gb/s        |             | 138     |         | $\mu\text{W}$ , OMA | 50/125 $\mu\text{m}$ fiber, 8   |
|   |             |         | 148     | $\mu\text{W}$ , OMA | 62.5/125 $\mu\text{m}$ fiber, 8 |
| Stressed receiver sensitivity (OMA)<br>2.125 Gb/s       |             | 96      |         | $\mu\text{W}$ , OMA | 50/125 $\mu\text{m}$ fiber, 3   |
|   |             |         | 109     | $\mu\text{W}$ , OMA | 62.5/125 $\mu\text{m}$ fiber, 3 |
| Stressed receiver sensitivity (OMA)<br>1.0625 Gb/s      |             | 55      |         | $\mu\text{W}$ , OMA | 50/125 $\mu\text{m}$ fiber, 4   |
|   |             |         | 67      | $\mu\text{W}$ , OMA | 62.5/125 $\mu\text{m}$ fiber, 4 |
| Return Loss   |             | 12      |         | dB                  |                                 |
| Signal Detect - Deassert                                | $P_D$       |         | 27.5    | $\mu\text{W}$ , OMA |                                 |
|   |             |         | -30     | -17.5               | dBm, avg                        |
| Signal Detect - Assert                                  | $P_A$       |         | 31      | $\mu\text{W}$ , OMA |                                 |
|   |             |         |         | -17.0               | dBm, avg                        |
| Loss of Signal Hysteresis                               | $P_A - P_D$ | 0.5     |         | dB                  |                                 |

**Notes:**

- 50/125  $\mu\text{m}$ . An OMA of 49 is approximately equal to an average power of -15 dBm with an Extinction Ratio of 9dB.
- 50/125  $\mu\text{m}$ . An OMA of 31 is approximately equal to an average power of -17 dBm with an Extinction Ratio of 9 dB.
- 2.125 Gb/s stressed receiver vertical eye closure penalty (ISI) min is 1.26 dB for 50  $\mu\text{m}$  fiber and 2.03 dB for 62.5  $\mu\text{m}$  fiber. Stressed receiver DCD component min (at TX) is 40 ps.
- 1.0625 Gb/s stressed receiver vertical eye closure penalty (ISI) min is 0.96 dB for 50  $\mu\text{m}$  fiber and 2.18 dB for 62.5  $\mu\text{m}$  fiber. Stressed receiver DCD component min (at TX) is 80 ps.
- These average power values are specified with an Extinction Ratio of 9 dB. The signal detect circuitry responds to valid 8B/10B encoded peak to peak input optical power, not average power.
- Input Optical Modulation Amplitude (commonly known as sensitivity) requires a valid 8B/10B encoded input.
- 50/125 $\mu\text{m}$ . An OMA of 61  $\mu\text{W}$  is approximately equal to an average power of -14 dBm with an Extinction Ratio of 9 dB.
- 4.25 Gb/s stressed receiver vertical eye closure penalty (ISI) min is 1.67 dB for 50  $\mu\text{m}$  fiber and 2.14 dB for 62.5  $\mu\text{m}$  fiber. Stressed receiver DCD component min (at TX) is 20 ps.

**Table 9. Transceiver Soft Diagnostic Timing Characteristics**(T<sub>C</sub> = -10°C to +85°C, V<sub>CC</sub>T, V<sub>CC</sub>R = 3.3V ± 10%)

| Parameter                                       | Symbol         | Minimum | Typical | Maximum | Unit | Notes |
|---|----------------|---------|---------|---------|------|-------|
| Hardware TX_DISABLE Assert Time                 | t_off          |         |         | 10      | μs   | 1     |
| Hardware TX_DISABLE Negate Time                 | t_on           |         |         | 1       | ms   | 2     |
| Time to initialize, including reset of TX_FAULT | t_init         |         |         | 300     | ms   | 3     |
| Hardware TX_DISABLE to Reset                    | t_reset        | 10      |         |         | μs   | 4     |
| Hardware Signal_Detect Deassert Time            | t_SD_off       |         |         | 100     | μs   | 5     |
| Hardware Signal_Detect Assert Time              | t_SD_on        |         |         | 100     | μs   | 6     |
| Software TX_DISABLE Assert Time                 | t_off_soft     |         |         | 100     | ms   | 7     |
| Software TX_DISABLE Negate Time                 | t_on_soft      |         |         | 100     | ms   | 8     |
| Software Tx_FAULT Assert Time                   | t_fault_soft   |         |         | 100     | ms   | 9     |
| Software Signal_Detect DeAssert Time            | t_SD_off_soft  |         |         | 100     | ms   | 10    |
| Software Signal_Detect Assert Time              | t_SD_on_soft   |         |         | 100     | ms   | 11    |
| Analog parameter data ready                     | t_data         |         |         | 1000    | ms   | 12    |
| Serial bus hardware ready                       | t_serial       |         |         | 300     | ms   | 13    |
| Write Cycle Time                                | t_write        |         |         | 10      | ms   | 14    |
| Serial ID Clock Rate                            | f_serial_clock |         |         | 400     | kHz  |       |

**Notes:**

1. Time from rising edge of TX\_DISABLE to when the optical output falls below 10% of nominal.
2. Time from falling edge of TX\_DISABLE to when the modulated optical output rises above 90% of nominal.
3. Time from power on or falling edge of Tx\_Disable to when the modulated optical output rises above 90% of nominal.
4. Time TX\_DISABLE must be held high to reset the laser fault shutdown circuitry.
5. Time from loss of optical signal to Signal Detect De-Assertion.
6. Time from valid optical signal to Signal Detect Assertion.
7. Time from two-wire interface assertion of TX\_DISABLE (A2h, byte 110, bit 6) to when the optical output falls below 10% of nominal. Measured from falling clock edge after stop bit of write transaction.
8. Time from two-wire interface de-assertion of TX\_DISABLE (A2h, byte 110, bit 6) to when the modulated optical output rises above 90% of nominal.
9. Time from fault to two-wire interface TX\_FAULT (A2h, byte 110, bit 2) asserted.
10. Time for two-wire interface de-assertion of Signal Detect (A2h, byte 110, bit 1) from loss of optical signal.
11. Time for two-wire interface assertion of Signal Detect (A2h, byte 110, bit 1) from presence of valid optical signal.
12. From power on to data ready bit asserted (A2h, byte 110, bit 0). Data ready indicates analog monitoring circuitry is functional.
13. Time from power on until module is ready for data transmission over the serial bus (reads or writes over A0h and A2h).
14. Time from stop bit to completion of a 1-8 byte write command. The I<sup>2</sup>C bus must be silent during Write Cycle Time.

**Table 10. PCB Assembly Process Compatibility**

| Parameter                            | Symbol              | Minimum | Typical | Maximum  | Unit   | Notes |
|--------------------------------------|---------------------|---------|---------|----------|--------|-------|
| Hand Lead Soldering Temperature/Time | $T_{SOLD}/t_{SOLD}$ |         |         | + 260/10 | °C/sec |       |
| Wave Soldering and Aqueous Wash      | $T_{SOLD}/t_{SOLD}$ |         |         | + 260/10 | °C/sec |       |
| Aqueous Wash Pressure                |                     |         |         | 110      | psi    |       |

**Table 11. Transceiver Digital Diagnostic Monitor (Real Time Sense) Characteristics**

( $T_C = -10\text{ }^\circ\text{C}$  to  $+85\text{ }^\circ\text{C}$ ,  $V_{CC1}, V_{CCR} = 3.3\text{ V} \pm 10\%$ )

| Parameter   | Symbol     | Min       | Units | Notes  |
|---|------------|-----------|-------|--|
| Transceiver (Internal) Temperature Accuracy                     | $T_{INT}$  | $\pm 3.0$ | °C    | Temperature is measured internal to the transceiver and does not reflect case temperature. Valid from = $-10\text{ }^\circ\text{C}$ to $+70\text{ }^\circ\text{C}$ internal transceiver temperature. |
| Transceiver (Internal) Supply Voltage Accuracy                  | $V_{INT}$  | $\pm 0.1$ | V     | Supply voltage is measured internal to the transceiver and can, with less accuracy, be correlated to voltage at the SFF Vcc pin. Valid over $3.3\text{ V} \pm 10\%$ .                                |
| Transmitter Laser DC Bias Current Accuracy                      | $I_{BIAS}$ | $\pm 10$  | %     | $I_{BIAS}$ is better than $\pm 10\%$ of the nominal value.   |
| Transmitted Optical Output Power Accuracy (AVG - average power) | $P_T$      | $\pm 3.0$ | dB    | Coupled into 50/125 $\mu\text{m}$ multimode fiber. Valid from 100 $\mu\text{W}$ ,avg to 500 $\mu\text{W}$ , avg.   |
| Received Optical Input Power Accuracy (Average power)           | $P_R$      | $\pm 3.0$ | dB    | Coupled from 50/125 $\mu\text{m}$ multimode fiber. Valid from 31 $\mu\text{W}$ ,OMA to 500 $\mu\text{W}$ ,OMA.   |

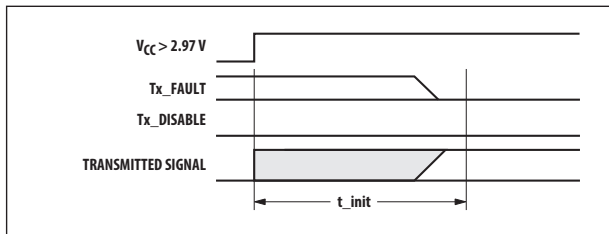

t-init: TX DISABLE NEGATED

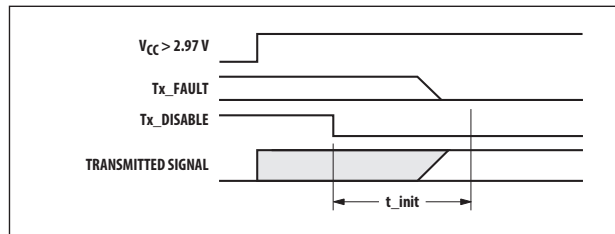

t-init: TX DISABLE ASSERTED

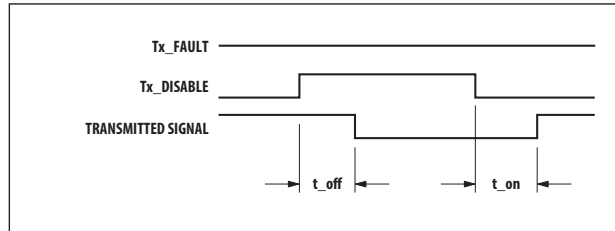

t-off & t-on: TX DISABLE ASSERTED THEN NEGATED

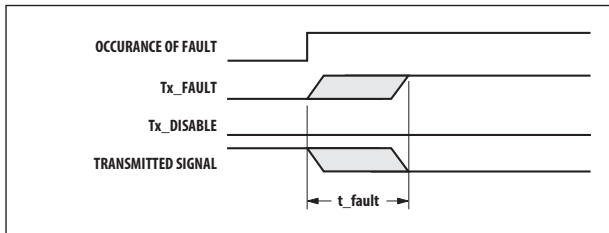

t-fault: TX FAULT ASSERTED, TX SIGNAL NOT RECOVERED

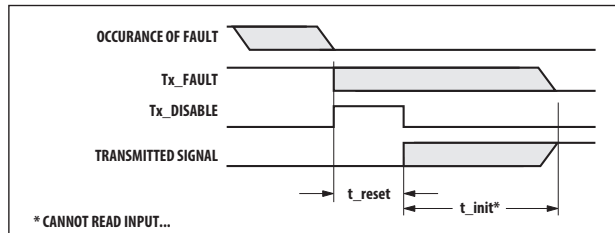

t-reset: TX DISABLE ASSERTED THEN NEGATED, TX SIGNAL RECOVERED

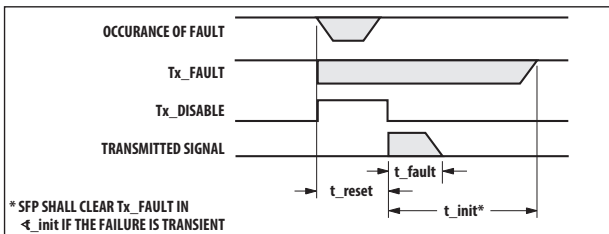

t-fault: TX DISABLE ASSERTED THEN NEGATED, TX SIGNAL NOT RECOVERED

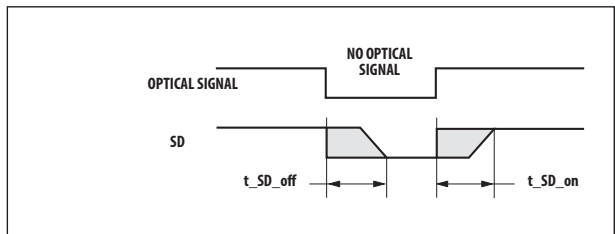

t<sub>SD\_off</sub> & t<sub>SD\_on</sub>

Figure 5. Transceiver Timing Diagrams (Tx\_FAULT as reported by A2h Byte 110 Bit 2)

**Table 12. EEPROM Serial ID Memory Contents – Conventional SFF Memory (Address A0h)**

| Byte #<br>Decimal | Data<br>Hex | Notes   | Byte #<br>Decimal | Data<br>Hex | Notes   |
|-------------------|-------------|---|-------------------|-------------|---|
| 0                 | 02          | SFF physical device (soldered device)               | 37                | 00          | Hex Byte of Vendor OUI <sup>4</sup>                       |
| 1                 | 04          | Serial ID function supported                        | 38                | 17          | Hex Byte of Vendor OUI <sup>4</sup>                       |
| 2                 | 07          | LC optical connector                                | 39                | 6A          | Hex Byte of Vendor OUI <sup>4</sup>                       |
| 3                 | 00          |   | 40                | 41          | "A" - Vendor Part Number ASCII character                  |
| 4                 | 00          |   | 41                | 46          | "F" - Vendor Part Number ASCII character                  |
| 5                 | 00          |   | 42                | 42          | "B" - Vendor Part Number ASCII character                  |
| 6                 | 00          |   | 43                | 52          | "R" - Vendor Part Number ASCII character                  |
| 7                 | 20          | Intermediate distance (per FC-PI)                   | 44                | 2D          | "-" - Vendor Part Number ASCII character                  |
| 8                 | 40          | Shortwave laser w/o OFC (open fiber control)        | 45                | 35          | "5" - Vendor Part Number ASCII character                  |
| 9                 | 0C          | Multi-mode 50 μm and 62.5 μm optical media          | 46                | 39          | "9" - Vendor Part Number ASCII character                  |
| 10                | 15          | 100, 200 & 400 MBytes/sec FC-PI speed <sup>1</sup>  | 47                | 52          | "R" - Vendor Part Number ASCII character                  |
| 11                | 01          | Compatible with 8B/10B encoded data                 | 48                | 35          | "5" - Vendor Part Number ASCII character                  |
| 12                | 2B          | 4300 MBit/sec nominal bit rate (4.25 Gbit/s)        | 49                | --          | "*" - Vendor Part Number ASCII character <sup>9</sup>     |
| 13                | 00          |   | 50                | 4C          | "L" - Vendor Part Number ASCII character                  |
| 14                | 00          |   | 51                | 5A          | "Z" - Vendor Part Number ASCII character                  |
| 15                | 00          |   | 52                | 20          | " " - Vendor Part Number ASCII character                  |
| 16                | 0F          | 150m of 50/125 μm fiber @ 4.25Gbit/sec <sup>2</sup> | 53                | 20          | " " - Vendor Part Number ASCII character                  |
| 17                | 07          | 70m of 62.5/125um fiber @ 4.25Gbit/sec <sup>3</sup> | 54                | 20          | " " - Vendor Part Number ASCII character                  |
| 18                | 00          |   | 55                | 20          | " " - Vendor Part Number ASCII character                  |
| 19                | 00          |   | 56                | 20          | " " - Vendor Part Number ASCII character                  |
| 20                | 41          | "A" - Vendor Name ASCII character                   | 57                | 20          | " " - Vendor Part Number ASCII character                  |
| 21                | 56          | "V" - Vendor Name ASCII character                   | 58                | 20          | " " - Vendor Part Number ASCII character                  |
| 22                | 41          | "A" - Vendor Name ASCII character                   | 59                | 20          | " " - Vendor Part Number ASCII character                  |
| 23                | 47          | "G" - Vendor Name ASCII character                   | 60                | 03          | Hex Byte of Laser Wavelength <sup>5</sup>                 |
| 24                | 4F          | "O" - Vendor Name ASCII character                   | 61                | 52          | Hex Byte of Laser Wavelength <sup>5</sup>                 |
| 25                | 20          | " " - Vendor Name ASCII character                   | 62                | 00          |   |
| 26                | 20          | " " - Vendor Name ASCII character                   | 63                |             | Checksum for Bytes 0-62 <sup>6</sup>                      |
| 27                | 20          | " " - Vendor Name ASCII character                   | 64                | 00          |   |
| 28                | 20          | " " - Vendor Name ASCII character                   | 65                | 1C          | Hardware SFF TX_DISABLE, TX_FAULT & Sig-Det               |
| 29                | 20          | " " - Vendor Name ASCII character                   | 66                | 00          |   |
| 30                | 20          | " " - Vendor Name ASCII character                   | 67                | 00          |   |
| 31                | 20          | " " - Vendor Name ASCII character                   | 68-83             |             | Vendor Serial Number ASCII characters <sup>7</sup>        |
| 32                | 20          | " " - Vendor Name ASCII character                   | 84-91             |             | Vendor Date Code ASCII characters <sup>8</sup>            |
| 33                | 20          | " " - Vendor Name ASCII character                   | 92                | 68          | Digital Diagnostics, Internal Cal, Rx Avg Pwr             |
| 34                | 20          | " " - Vendor Name ASCII character                   | 93                | F0          | A/W, Soft TX_DISABLE, TX_FAULT & "RX_LOS" (signal detect) |
| 35                | 20          | " " - Vendor Name ASCII character                   | 94                | 01          | SFF-8472 Compliance to revision 9.3                       |
| 36                | 00          |   | 95                |             | Checksum for Bytes 64-94 <sup>6</sup>                     |
|                   |             |   | 96 - 255          | 00          |   |

**Notes:**

1. FC-PI speed 100 MBytes/sec is a serial bit rate of 1.0625 Gbit/sec. 200 MBytes/sec is a serial bit rate of 2.125 Gbit/sec. 400 MBytes/sec is a serial bit rate of 4.25 Gbit/sec.
2. Link distance with 50/125um cable at 1.0625 Gbit/sec is 500m. Link distance at 2.125 Gbit/sec is 300m.
3. Link distance with 62.5/125um cable at 1.0625 Gbit/sec is 300m. Link distance with 62.5/125um cable at 2.125 Gbit/sec is 150m.
4. The IEEE Organizationally Unique Identifier (OUI) assigned to Avago Technologies is 00-17-6A (3 bytes of hex).
5. Laser wavelength is represented in 16 unsigned bits. The hex representation of 850 (nm) is 0352.
6. Addresses 63 and 95 are checksums calculated (per SFF-8472 and SFF-8074i) and stored prior to product shipment.
7. Addresses 68-83 specify the AFBR-59R5LZ ASCII serial number and will vary on a per unit basis.
8. Addresses 84-91 specify the AFBR-59R5LZ ASCII date code and will vary on a per date code basis.
9. For AFBR-59R5LZ, address 49-51 contains "L", "Z", " " (Hex 4C 5A and 20). For AFBR-59R5ALZ, address 49-51 contains "A", "L", "Z" (Hex 41 4C 5A).



**Table 13. EEPROM Serial ID Memory Contents – Enhanced Feature Set Memory (Address A2h)**

| Byte #<br>Decimal | Notes                                      | Byte #<br>Decimal | Notes                                       | Byte #<br>Decimal | Notes                              |
|-------------------|--|-------------------|---|-------------------|------------------------------------|
| 0                 | Temp H Alarm MSB <sup>1</sup>              | 26                | Tx Pwr L Alarm MSB <sup>4</sup>             | 104               | Real Time Rx Pwr, MSB <sup>5</sup> |
| 1                 | Temp H Alarm LSB <sup>1</sup>              | 27                | Tx Pwr L Alarm LSB <sup>4</sup>             | 105               | Real Time Rx Pwr, LSB <sup>5</sup> |
| 2                 | Temp L Alarm MSB <sup>1</sup>              | 28                | Tx Pwr H Warning MSB <sup>4</sup>           | 106               | Reserved                           |
| 3                 | Temp L Alarm LSB <sup>1</sup>              | 29                | Tx Pwr H Warning LSB <sup>4</sup>           | 107               | Reserved                           |
| 4                 | Temp H Warning MSB <sup>1</sup>            | 30                | Tx Pwr L Warning MSB <sup>4</sup>           | 108               | Reserved                           |
| 5                 | Temp H Warning LSB <sup>1</sup>            | 31                | Tx Pwr L Warning LSB <sup>4</sup>           | 109               | Reserved                           |
| 6                 | Temp L Warning MSB <sup>1</sup>            | 32                | Rx Pwr H Alarm MSB <sup>5</sup>             | 110               | Status/Control - See Table 14      |
| 7                 | Temp L Warning LSB <sup>1</sup>            | 33                | Rx Pwr H Alarm LSB <sup>5</sup>             | 111               | Reserved                           |
| 8                 | V <sub>CC</sub> H Alarm MSB <sup>2</sup>   | 34                | Rx Pwr L Alarm MSB <sup>5</sup>             | 112               | Flag Bits - See Table 15           |
| 9                 | V <sub>CC</sub> H Alarm LSB <sup>2</sup>   | 35                | Rx Pwr L Alarm LSB <sup>5</sup>             | 113               | Flag Bits - See Table 15           |
| 10                | V <sub>CC</sub> L Alarm MSB <sup>2</sup>   | 36                | Rx Pwr H Warning MSB <sup>5</sup>           | 114               | Reserved                           |
| 11                | V <sub>CC</sub> L Alarm LSB <sup>2</sup>   | 37                | Rx Pwr H Warning LSB <sup>5</sup>           | 115               | Reserved                           |
| 12                | V <sub>CC</sub> H Warning MSB <sup>2</sup> | 38                | Rx Pwr L Warning MSB <sup>5</sup>           | 116               | Flag Bits - See Table 15           |
| 13                | V <sub>CC</sub> H Warning LSB <sup>2</sup> | 39                | Rx Pwr L Warning LSB <sup>5</sup>           | 117               | Flag Bits - See Table 15           |
| 14                | V <sub>CC</sub> L Warning MSB <sup>2</sup> | 40-55             | Reserved                                    | 118               | Reserved                           |
| 15                | V <sub>CC</sub> L Warning LSB <sup>2</sup> | 56-94             | External Calibration Constants <sup>6</sup> | 119               | Reserved                           |
| 16                | Tx Bias H Alarm MSB <sup>3</sup>           | 95                | Checksum for Bytes 0-94 <sup>7</sup>        | 120-127           | Reserved                           |
| 17                | Tx Bias H Alarm LSB <sup>3</sup>           | 96                | Real Time Temperature MSB <sup>1</sup>      | 128-247           | Customer Writeable <sup>8</sup>    |
| 18                | Tx Bias L Alarm MSB <sup>3</sup>           | 97                | Real Time Temperature LSB <sup>1</sup>      | 248-254           | Vendor Specific                    |
| 19                | Tx Bias L Alarm LSB <sup>3</sup>           | 98                | Real Time V <sub>CC</sub> MSB <sup>2</sup>  |                   |                                    |
| 20                | Tx Bias H Warning MSB <sup>3</sup>         | 99                | Real Time V <sub>CC</sub> LSB <sup>2</sup>  |                   |                                    |
| 21                | Tx Bias H Warning LSB <sup>3</sup>         | 100               | Real Time Tx Bias MSB <sup>3</sup>          |                   |                                    |
| 22                | Tx Bias L Warning MSB <sup>3</sup>         | 101               | Real Time Tx Bias LSB <sup>3</sup>          |                   |                                    |
| 23                | Tx Bias L Warning LSB <sup>3</sup>         | 102               | Real Time Tx Power MSB <sup>4</sup>         |                   |                                    |
| 24                | Tx Pwr H Alarm MSB <sup>4</sup>            | 103               | Real Time Tx Power LSB <sup>4</sup>         |                   |                                    |
| 25                | Tx Pwr H Alarm LSB <sup>4</sup>            |                   |   |                   |                                    |

**Notes:**

1. Temperature (Temp) is decoded as a 16 bit signed twos complement integer in increments of 1/256 degrees C.
2. Supply Voltage (V<sub>CC</sub>) is decoded as a 16 bit unsigned integer in increments of 100 uV.
3. Laser bias current (Tx Bias) is decoded as a 16 bit unsigned integer in increments of 2 uA.
4. Transmitted average optical power (Tx Pwr) is decoded as a 16 bit unsigned integer in increments of 0.1 uW.
5. Received average power (RX Pwr) is decoded as a 16 bit unsigned integer in increments of 0.1 uW.
6. Bytes 56-94 are not intended for use with AFBR-59R5LZ, but have been set to default values per SFF-8472.
7. Byte 95 is a checksum calculated (per SFF-8472) and stored prior to product shipment.
8. Bytes 128-247 are write enabled (customer writeable) .

**Table 14. EEPROM Serial ID Memory Contents – Soft Commands (Address A2h, Byte 110)**

| Bit # | Status/Control Name | Description   | Notes |
|-------|---------------------|---|-------|
| 7     | TX_DISABLE State    | Digital state of SFF TX_DISABLE Input Pin (1 = TX_DISABLE asserted)               | 1     |
| 6     | Soft TX_DISABLE     | Read/write bit for changing digital state of SFF TX_DISABLE function <sup>1</sup> | 1, 2  |
| 5     | reserved            |   |       |
| 4     | reserved            |   |       |
| 3     | reserved            |   |       |
| 2     | TX_FAULT State      | Digital state of the laser fault function (1 = Laser Fault Detected)              | 1     |
| 1     | Signal Detect State | Digital state of the SFF Sig_Det Output Pin (1 = Signal Detect DeAsserted)        | 1, 4  |
| 0     | Data Ready (Bar)    | Indicates transceiver is powered and real time sense data is ready. (0 = Ready)   | 1     |

**Notes:**

1. The response time for soft commands of the AFBR-59R5LZ is 100msec as specified by the MSA SFF-8472
2. Bit 6 is logic OR'd with the SFF TX\_DISABLE input pin 8 either asserted will disable the SFF transmitter.
3. AFBR-59R5LZ meets the MSA SFF-8472 data ready timing of 1000 msec.
4. The logic level of the register "Signal Detect State" is inverse to the "Signal Detect" HW pin.

**Table 15. EEPROM Serial ID Memory Contents – Alarms and Warnings (Address A2h, Bytes 112, 113, 116, 117)**

| Byte | Bit | Flag Bit Name                | Description  |
|------|-----|------------------------------|--|
| 112  | 7   | Temp High Alarm              | Set when transceiver internal temperature exceeds high alarm threshold.      |
|      | 6   | Temp Low Alarm               | Set when transceiver internal temperature exceeds low alarm threshold.       |
|      | 5   | V <sub>CC</sub> High Alarm   | Set when transceiver internal supply voltage exceeds high alarm threshold.   |
|      | 4   | V <sub>CC</sub> Low Alarm    | Set when transceiver internal supply voltage exceeds low alarm threshold.    |
|      | 3   | Tx Bias High Alarm           | Set when transceiver laser bias current exceeds high alarm threshold.        |
|      | 2   | Tx Bias Low Alarm            | Set when transceiver laser bias current exceeds low alarm threshold.         |
|      | 1   | Tx Power High Alarm          | Set when transmitted average optical power exceeds high alarm threshold.     |
|      | 0   | Tx Power Low Alarm           | Set when transmitted average optical power exceeds low alarm threshold.      |
| 113  | 7   | Rx Power High Alarm          | Set when received average optical power exceeds high alarm threshold.        |
|      | 6   | Rx Power Low Alarm           | Set when received average optical power exceeds low alarm threshold.         |
|      | 0-5 | reserved                     |  |
| 116  | 7   | Temp High Warning            | Set when transceiver internal temperature exceeds high warning threshold.    |
|      | 6   | Temp Low Warning             | Set when transceiver internal temperature exceeds low warning threshold.     |
|      | 5   | V <sub>CC</sub> High Warning | Set when transceiver internal supply voltage exceeds high warning threshold. |
|      | 4   | V <sub>CC</sub> Low Warning  | Set when transceiver internal supply voltage exceeds low warning threshold.  |
|      | 3   | Tx Bias High Warning         | Set when transceiver laser bias current exceeds high warning threshold.      |
|      | 2   | Tx Bias Low Warning          | Set when transceiver laser bias current exceeds low warning threshold.       |
|      | 1   | Tx Power High Warning        | Set when transmitted average optical power exceeds high warning threshold.   |
|      | 0   | Tx Power Low Warning         | Set when transmitted average optical power exceeds low warning threshold.    |
| 117  | 7   | Rx Power High Warning        | Set when received average optical power exceeds high warning threshold.      |
|      | 6   | Rx Power Low Warning         | Set when received average optical power exceeds low warning threshold.       |
|      | 0-5 | reserved                     |  |

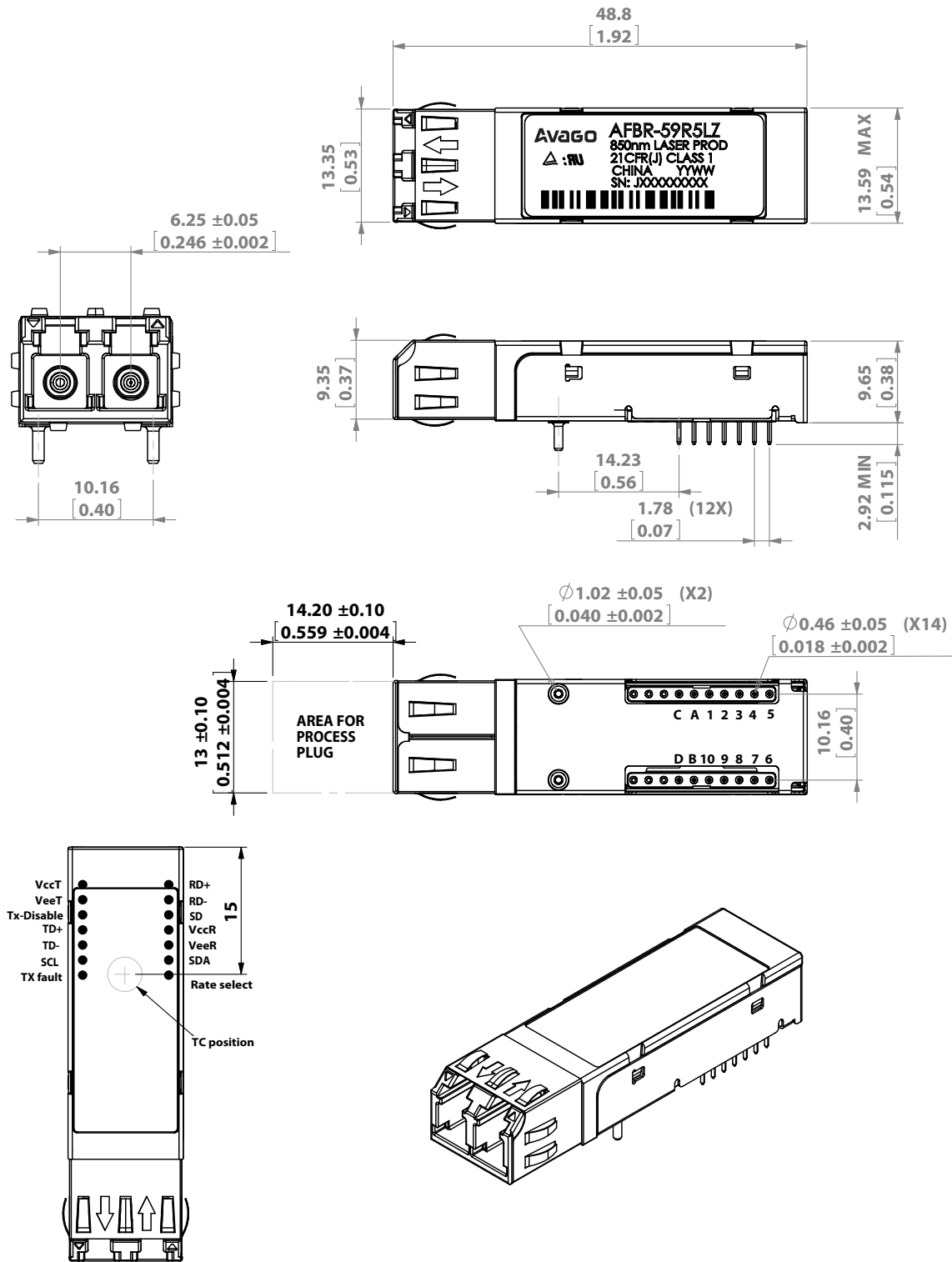

Figure 6. Mechanical Drawing - AFBR-59R5LZ

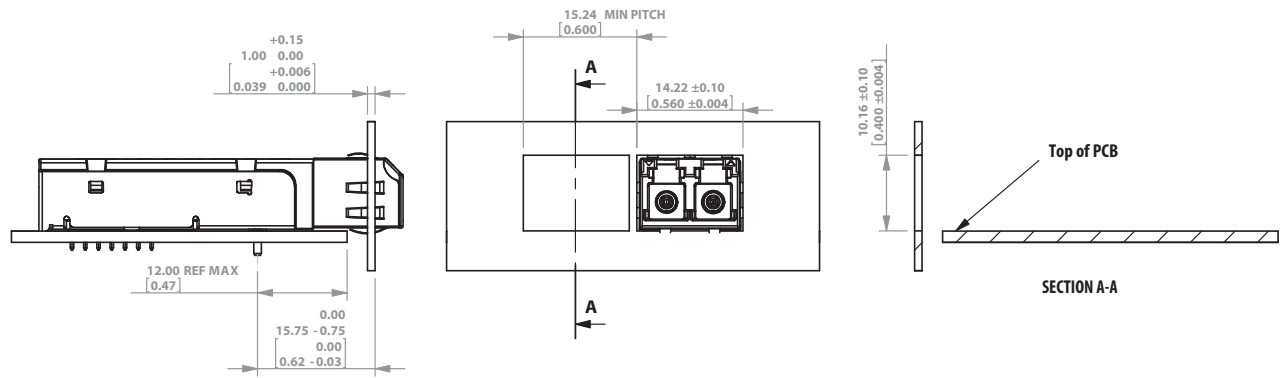
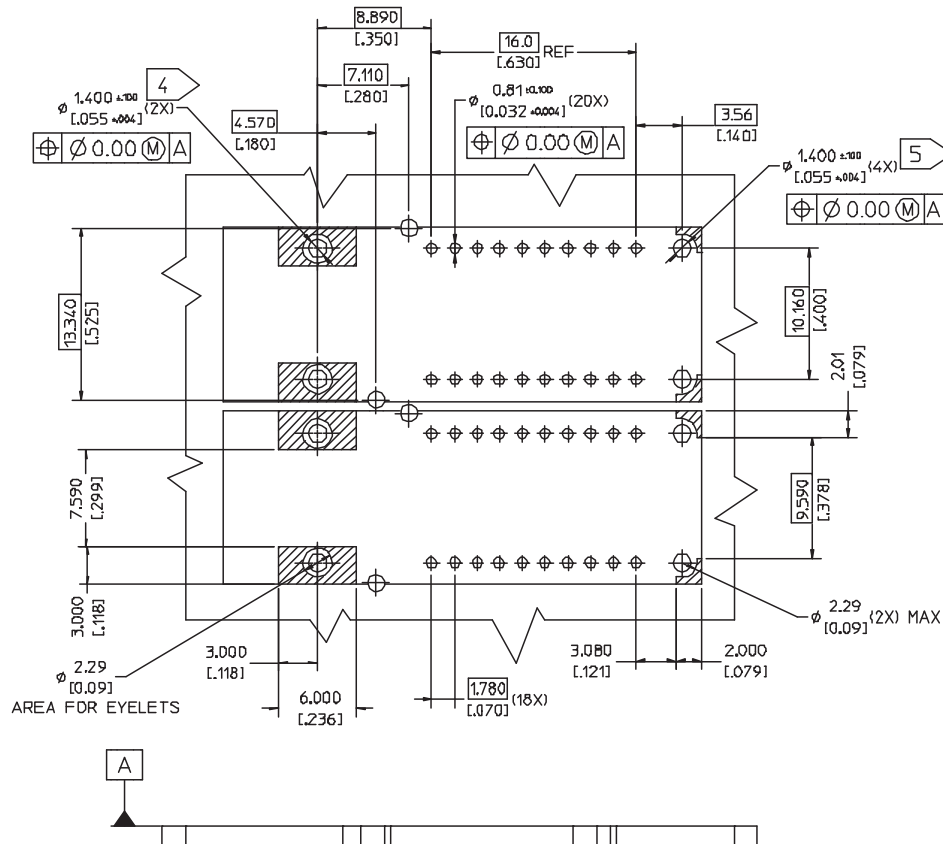

Figure 7. Assembly Drawing



1. THIS PAGE DESCRIBE THE RECOMMENDED CIRCUIT BOARD LAYOUT FOR THE SFF TRANSCEIVER.
2. THE HATCHED AREAS ARE KEEP-OUT AREAS RESERVED FOR HOUSING STANDOFFS. NO METAL TRACES OF GROUND CONNECTION IN KEEP-OUT AREA.
3. 20 PINS MODULE SHOWN. 10 PIN MODULE REQUIRES ONLY 16 PCB HOLES.

- 4 HOLES FOR MOUNTING STUDS MUST BE TIED TO CHASSIS GROUND.
- 5 HOLES FOR HOUSING LEADS MUST BE TIED TO SIGNAL GROUND

Figure 8. Board Layout

For product information and a complete list of distributors, please go to our web site: [www.avagotech.com](http://www.avagotech.com)

Avago, Avago Technologies, and the A logo are trademarks of Avago Technologies in the United States and other countries. Data subject to change. Copyright © 2005-2015 Avago Technologies. All rights reserved. Obsoletes 5989-3624EN AV02-0109EN - May 13, 2015

**AVAGO**  
TECHNOLOGIES