



Chipsmall Limited consists of a professional team with an average of over 10 year of expertise in the distribution of electronic components. Based in Hongkong, we have already established firm and mutual-benefit business relationships with customers from,Europe,America and south Asia,supplying obsolete and hard-to-find components to meet their specific needs.

With the principle of "Quality Parts,Customers Priority,Honest Operation,and Considerate Service",our business mainly focus on the distribution of electronic components. Line cards we deal with include Microchip,ALPS,ROHM,Xilinx,Pulse,ON,Everlight and Freescale. Main products comprise IC,Modules,Potentiometer,IC Socket,Relay,Connector.Our parts cover such applications as commercial,industrial, and automotives areas.

We are looking forward to setting up business relationship with you and hope to provide you with the best service and solution. Let us make a better world for our industry!



Contact us

Tel: +86-755-8981 8866 Fax: +86-755-8427 6832

Email & Skype: info@chipsmall.com Web: www.chipsmall.com

Address: A1208, Overseas Decoration Building, #122 Zhenhua RD., Futian, Shenzhen, China



AFS20 series SAW Filter Evaluation Board

AFS2016-Eval

Moisture Sensitivity Level – N/A



RoHS/RoHS II compliant



26.75 x 42.6 mm

DESCRIPTION:

AFS20 Evaluation boards are designed to provide a means to assess the performance of AFS20 series of SAW Band Pass Filters. The board is designed with a provision for matching components on both input and output ports of the filter.

To complete the electrical path, resistors R1 & R2 are in-circuit with 0Ω value. The land pattern for C1 C2, C3 & C4, along with the land pattern for R1 & R2 can be used to create a matching circuit using a combination of inductors and capacitors as desired.

By default, the AFS20 series of SAW Band Pass Filters are designed into a matched impedance of 50Ω's, so these evaluation boards can be used as received. Simply solder down the AFS20 series of filter on the provided land pattern, and connect the Input and Output ports, using SMA to BNC or SMA to N-Type connectors to a Network Analyzer.

OPTIONS AND PART IDENTIFICATION

AFS2016-EVAL

OUTLINE DIMENSIONS

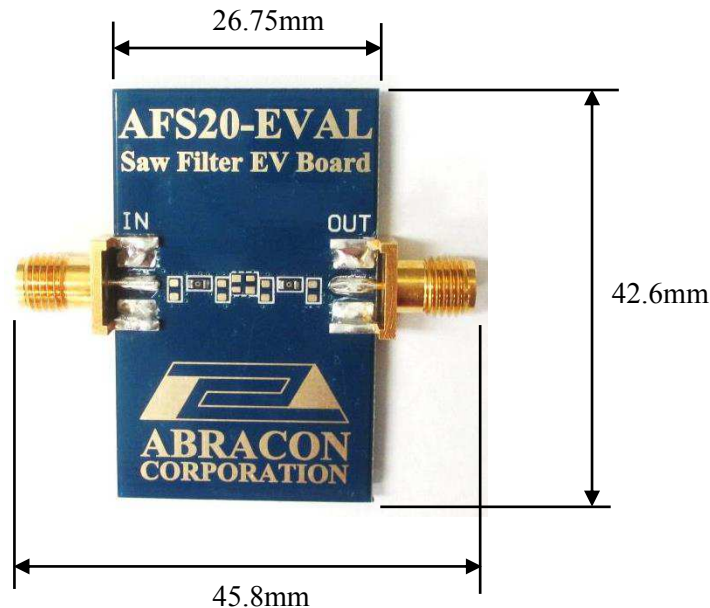

AFS20 series SAW Filter Evaluation Board

AFS2016-Eval



RoHS/RoHS II compliant



SCHEMATIC

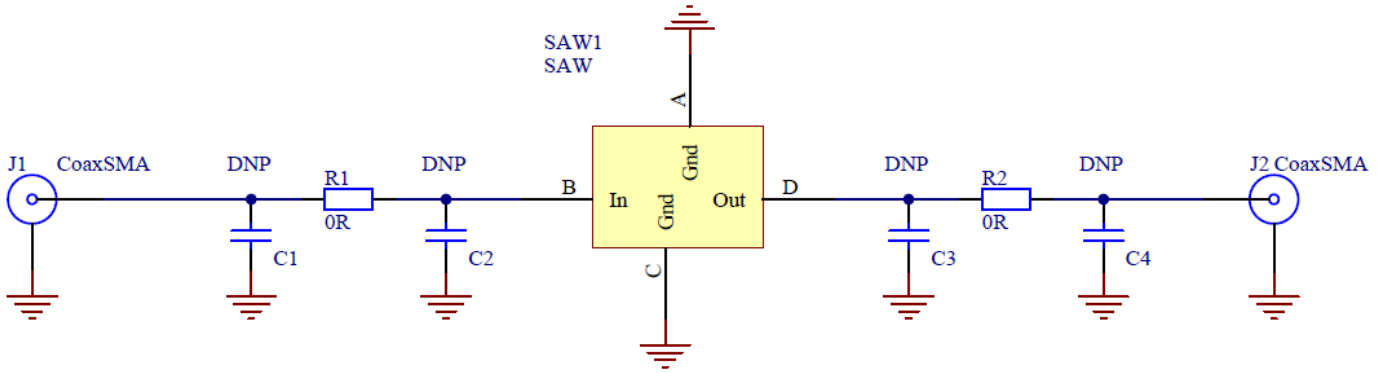

LAYOUT

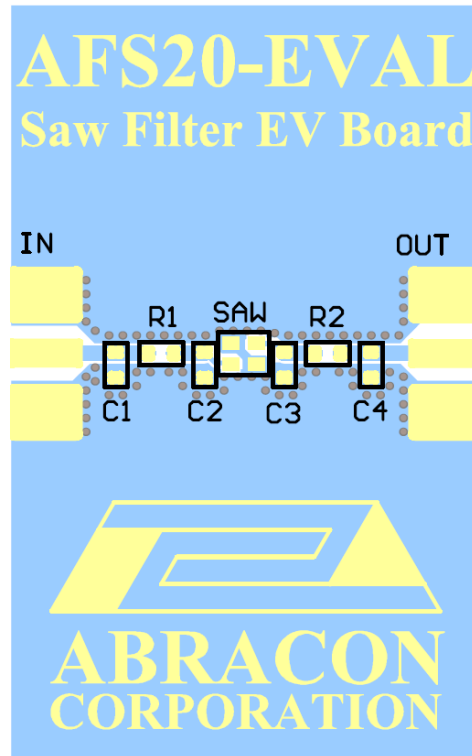

ATTENTION: Abracon Corporation's products are COTS – Commercial-Off-The-Shelf products; suitable for Commercial, Industrial and, where designated, Automotive Applications. Abracon's products are not specifically designed for Military, Aviation, Aerospace, Life-dependant Medical applications or any application requiring high reliability where component failure could result in loss of life and/or property. For applications requiring high reliability and/or presenting an extreme operating environment, written consent and authorization from Abracon Corporation is required. Please contact Abracon Corporation for more information.

ABRACON IS
ISO9001:2008
CERTIFIED



ABRACON
CORPORATION

2 Faraday, Suite# B | Irvine | CA 92618 **Revised: 01.26.15**

Ph. 949.546.8000 | Fax. 949.546.8001

Visit www.abracon.com for Terms and Conditions of Sale