



Chipsmall Limited consists of a professional team with an average of over 10 year of expertise in the distribution of electronic components. Based in Hongkong, we have already established firm and mutual-benefit business relationships with customers from,Europe,America and south Asia,supplying obsolete and hard-to-find components to meet their specific needs.

With the principle of “Quality Parts,Customers Priority,Honest Operation,and Considerate Service”,our business mainly focus on the distribution of electronic components. Line cards we deal with include Microchip,ALPS,ROHM,Xilinx,Pulse,ON,Everlight and Freescale. Main products comprise IC,Modules,Potentiometer,IC Socket,Relay,Connector.Our parts cover such applications as commercial,industrial, and automotives areas.

We are looking forward to setting up business relationship with you and hope to provide you with the best service and solution. Let us make a better world for our industry!



Contact us

Tel: +86-755-8981 8866 Fax: +86-755-8427 6832

Email & Skype: info@chipsmall.com Web: www.chipsmall.com

Address: A1208, Overseas Decoration Building, #122 Zhenhua RD., Futian, Shenzhen, China



Part Number: AG1262-1
Normally Open Tip Over Switch
Product Data Sheet

PICTURE



✓ RoHS Compliant

OPERATION

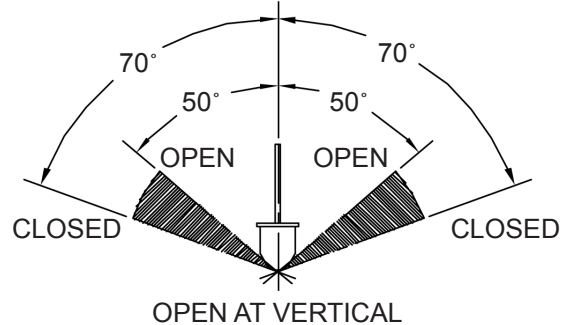

FEATURES

- Resistant to Ambient Environmental Conditions
- Case Material : Un-Plated
- Mechanical Stress Resistant
- Hermetically Sealed & Inert Gas Filled

DIMENSIONS

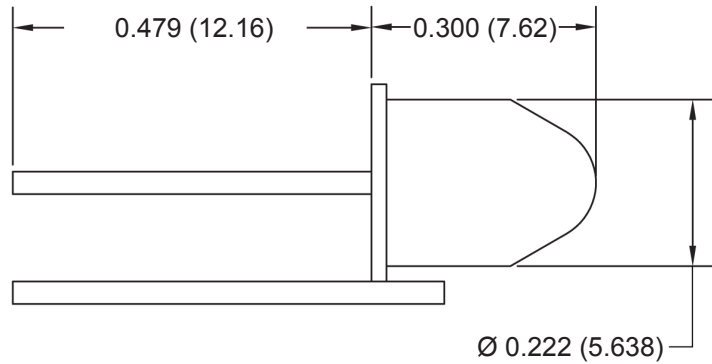
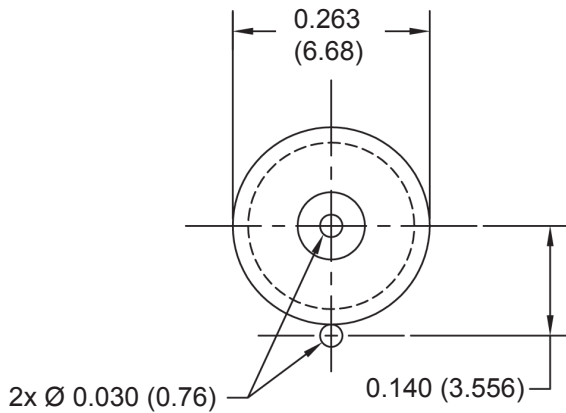

Drawings not to scale.
 All dimensions in inches (mm) nominal.

SPECIFICATION

Contact Rating	0.001 A at 3.6V DC
Voltage Drop	10% MAX at a Load of 27 Kohms, 3.6 VDC
Contact Resistance	1000 Ohms MAX
Make Angle	50° - 70° from vertical
Operating Temperature	-37° +100°C

As part of the company policy of continued product improvement, specifications may change without notice. Our sales office will be pleased to help you with the latest information on this product range and the details of our full design and manufacturing service. All products are supplied to our standard conditions of sale unless otherwise agreed in writing.

Phone: (1) 973 777 6900

www.comus-intl.com

Fax: (1) 973 777 8405