



Chipsmall Limited consists of a professional team with an average of over 10 year of expertise in the distribution of electronic components. Based in Hongkong, we have already established firm and mutual-benefit business relationships with customers from,Europe,America and south Asia,supplying obsolete and hard-to-find components to meet their specific needs.

With the principle of “Quality Parts,Customers Priority,Honest Operation,and Considerate Service”,our business mainly focus on the distribution of electronic components. Line cards we deal with include Microchip,ALPS,ROHM,Xilinx,Pulse,ON,Everlight and Freescale. Main products comprise IC,Modules,Potentiometer,IC Socket,Relay,Connector.Our parts cover such applications as commercial,industrial, and automotives areas.

We are looking forward to setting up business relationship with you and hope to provide you with the best service and solution. Let us make a better world for our industry!



## Contact us

Tel: +86-755-8981 8866 Fax: +86-755-8427 6832

Email & Skype: info@chipsmall.com Web: www.chipsmall.com

Address: A1208, Overseas Decoration Building, #122 Zhenhua RD., Futian, Shenzhen, China



# AG934-07E AAT101 Full-Bridge Angle Sensor Evaluation Kit

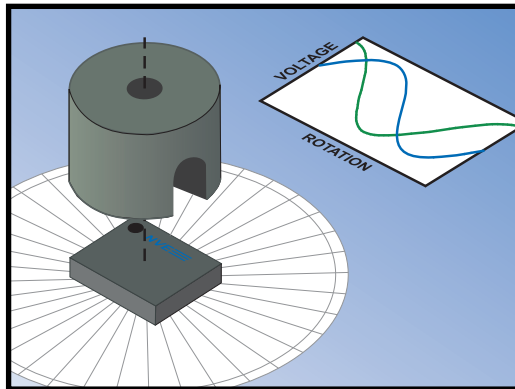

SB-00-065

# Kit Overview

---

## Evaluation Kit Features

- AAT101-10E full-bridge angle sensor
- Part # 12426 split-pole Alnico 5 round horseshoe magnet
- Magnet locating fixture

## AAT101-10E Features

- Tunneling Magnetoresistance (TMR) technology
- Full-bridge differential outputs
- 625 k $\Omega$  typical bridge resistance for low power
- 400 mV/V typical output signal
- 1.5% maximum nonsinusoidality error
- Wide sensor-magnet airgap tolerance
- Sine and cosine outputs for direction detection
- Ultraminiature 2.5 mm x 2.5 mm x 0.8 mm TDFN6 package

## AAT-Series Sensor Applications

- Rotary encoders
- Motor shaft position sensors
- Internet-of-Things sensor nodes
- Battery or harvested power

## Available AAT-Series Sensors

Part Number	Configuration	Typ. Output (ea. output; p-p)	Required Field	Typ. Device Resistance
AAT001-10E	Half-bridge	200 mV/V	30 Oe	1.25 M $\Omega$
AAT003-10E	Half-bridge	200 mV/V	30 Oe	40 K $\Omega$
AAT006-10E	Half-bridge	200 mV/V	15 Oe	1.5 M $\Omega$
AAT009-10E	Half-bridge	200 mV/V	30 Oe	6 M $\Omega$
AAT101-10E	Full-bridge	400 mV/V	30 Oe	625 k $\Omega$

Visit [www.nve.com](http://www.nve.com) for complete product specifications.

---

## Quick Start

---

- ⇒ Connect  $V_{CC}$  to a power supply (5.5 V maximum) or a battery.
- ⇒ Connect “SIN” and “COS” outputs to meters or differential oscilloscope inputs.
- ⇒ Place the split-pole magnet in the Plexiglas pocket.
- ⇒ Rotate the magnet.

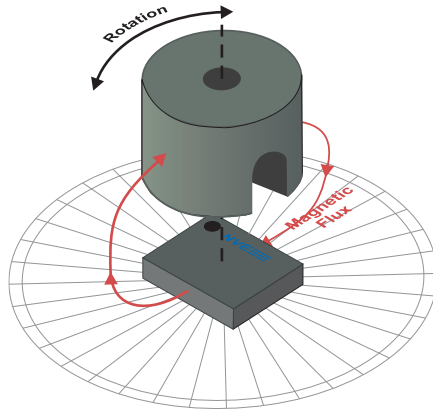

- ⇒ The outputs should be similar to this graph:

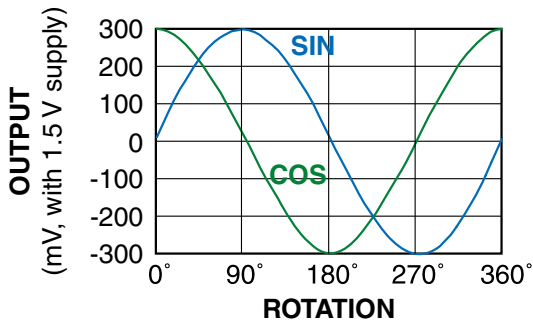

The output is insensitive to magnet spacing over a wide range. Signal is lost if the magnet is too far away; if the magnet is too close the outputs will be non-sinusoidal. A relatively large magnet-sensor airgap is possible with the magnet provided with the kit, although smaller magnets will require a smaller gap.

---

# Evaluation Board Layout

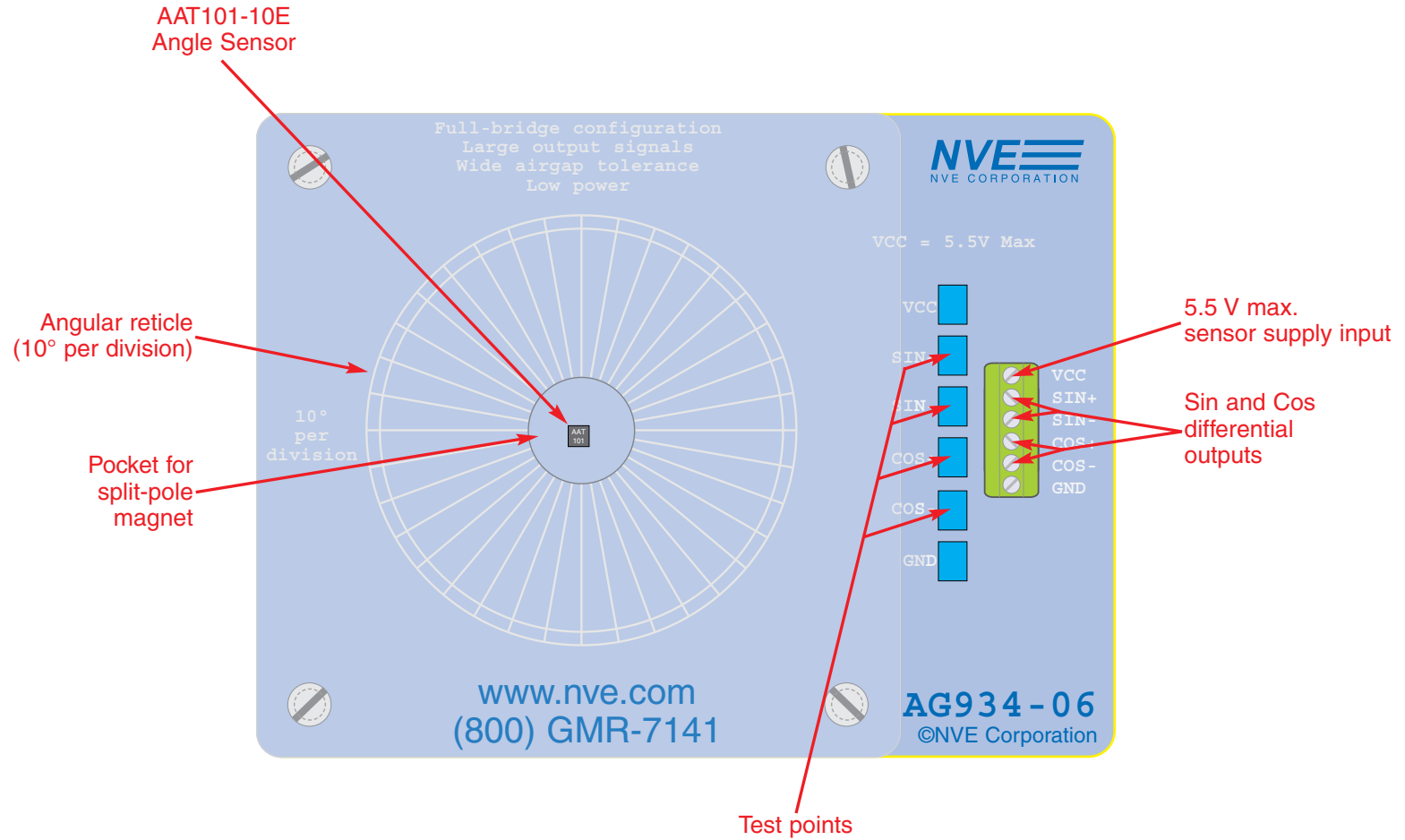

# PCB Assembly

---

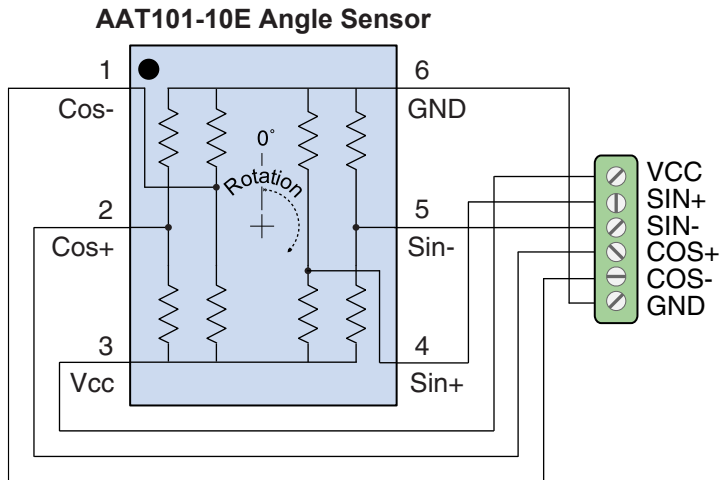

**AG934-07E Evaluation Kit schematic.**

The AAT101-10E angle sensor is a low power, full-bridge, high-output magnetic sensor element for position measurements based on a rotating magnetic field.

The PCB assembly provides connections to each of the six sensor pins via test points or screw terminals. The sensor can be powered with up to 5.5 V. Output sensitivity increases proportionately to the sensor supply voltage, as does current consumption.

Sensor outputs can be connected to meters, high-impedance oscilloscope inputs, or high input impedance external circuitry.

---



# Principles of Operation

---

The heart of AAT101 sensors is eight unique Tunneling Magnetoresistance (TMR) elements. Each of the eight sensor elements contains two magnetic layers: a “pinned,” or fixed direction layer; and a movable-direction, or “free” layer. The elements are configured as two four-element full bridges. The two bridges are 90° out of phase to provide quadrature outputs. TMR technology enables low power and miniaturization, making the sensors ideal for battery operation.

In a typical configuration, an external magnet provides a saturating magnetic field in the plane of the sensor, as illustrated below for a bar magnet and a radially-magnetized disk magnet:

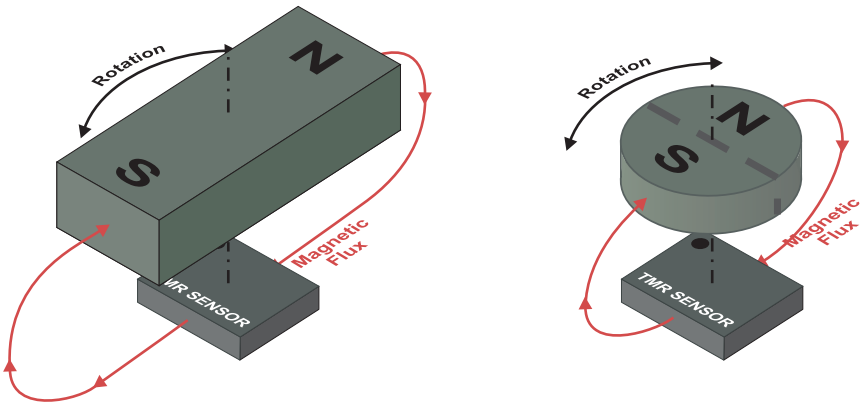

As the field rotates, half of the elements increase in resistance and half decrease. This ensures that each bridge resistance, the total device resistance, and the output impedances remain constant with rotation.

---

### **Limited Warranty and Liability**

Information in this document is believed to be accurate and reliable. However, NVE does not give any representations or warranties, expressed or implied, as to the accuracy or completeness of such information and shall have no liability for the consequences of use of such information. In no event shall NVE be liable for any indirect, incidental, punitive, special or consequential damages (including, without limitation, lost profits, lost savings, business interruption, costs related to the removal or replacement of any products or rework charges) whether or not such damages are based on tort (including negligence), warranty, breach of contract or any other legal theory.

### **Right to Make Changes**

NVE reserves the right to make changes to information published in this document including, without limitation, specifications and product descriptions at any time and without notice.

### **Use in Life-Critical or Safety-Critical Applications**

Unless NVE and a customer explicitly agree otherwise in writing, NVE products are not designed, authorized or warranted to be suitable for use in life support, life-critical or safety-critical devices or equipment. NVE accepts no liability for inclusion or use of NVE products in such applications and such inclusion or use is at the customer's own risk. Should the customer use NVE products for such application whether authorized by NVE or not, the customer shall indemnify and hold NVE harmless against all claims and damages.

### **Applications**

Applications described in this document are illustrative only. NVE makes no representation or warranty that such applications will be suitable for the specified use without further testing or modification. Customers are responsible for the design and operation of their applications and products using NVE products, and NVE accepts no liability for any assistance with applications or customer product design. It is customer's sole responsibility to determine whether the NVE product is suitable and fit for the customer's applications and products planned, as well as for the planned application and use of customer's third party customers. Customers should provide appropriate design and operating safeguards to minimize the risks associated with their applications and products. NVE does not accept any liability related to any default, damage, costs or problem which is based on any weakness or default in the customer's applications or products, or the application or use by customer's third party customers. The customer is responsible for all necessary testing for the customer's applications and products using NVE products in order to avoid a default of the applications and the products or of the application or use by customer's third party customers. NVE accepts no liability in this respect.

## **An ISO 9001 Certified Company**

NVE Corporation  
11409 Valley View Road  
Eden Prairie, MN 55344-3617

©NVE Corporation

All rights are reserved. Reproduction in whole or in part is prohibited without the prior written consent of the copyright owner.

Manual No.: SB-00-065