



Chipsmall Limited consists of a professional team with an average of over 10 year of expertise in the distribution of electronic components. Based in Hongkong, we have already established firm and mutual-benefit business relationships with customers from,Europe,America and south Asia,supplying obsolete and hard-to-find components to meet their specific needs.

With the principle of “Quality Parts,Customers Priority,Honest Operation,and Considerate Service”,our business mainly focus on the distribution of electronic components. Line cards we deal with include Microchip,ALPS,ROHM,Xilinx,Pulse,ON,Everlight and Freescale. Main products comprise IC,Modules,Potentiometer,IC Socket,Relay,Connector.Our parts cover such applications as commercial,industrial, and automotives areas.

We are looking forward to setting up business relationship with you and hope to provide you with the best service and solution. Let us make a better world for our industry!



Contact us

Tel: +86-755-8981 8866 Fax: +86-755-8427 6832

Email & Skype: info@chipsmall.com Web: www.chipsmall.com

Address: A1208, Overseas Decoration Building, #122 Zhenhua RD., Futian, Shenzhen, China



LOW SENSITIVITY MICROPOWER OMNIPOLAR HALL-EFFECT SWITCH

Description

The AH1815 is a low-sensitivity, micro-power Omnipolar Hall effect switch IC, designed for portable and battery powered consumer equipment for home appliance and industrial applications such as smart-meter magnetic-tamper detection. Based on two sensitive Hall effect plates and a chopper-stabilized architecture, the AH1815 provides a reliable solution over the whole operating range. To support portable and battery powered equipment, the design has been optimized to operate over the supply range of 2.5V to 5.5V and consumes only 24µW with a supply of 3V.

The single open drain output can switch on with either a north or south pole of sufficient strength. When the magnetic flux density (B) perpendicular to the package is larger than operating point (Bop) the output is switched on (pulled low). The output is turned off when B becomes lower than the releasing point (Brp). The output will remain off when there is no magnetic field.

Features

- Omnipolar (North or South pole) Operation
- Low Sensitivity
- Single Open Drain Output
- Micropower Operation
- 2.5V to 5.5V Operating Range
- Chopper Stabilized Design Provides Superior Temperature Stability
- Minimal Switch Point Drift
- Enhanced Immunity to Stress
- Good RF Noise Immunity
- -40°C to +125°C Operating Temperature
- ESD (HBM) > 6KV
- Small Low Profile SOT553 and Industry Standard SC59 and SIP-3 Packages
- **Totally Lead-Free & Fully RoHS Compliant (Notes 1 & 2)**
- **Halogen and Antimony Free. "Green" Device (Note 3)**

Notes: 1. No purposely added lead. Fully EU Directive 2002/95/EC (RoHS) & 2011/65/EU (RoHS 2) compliant.
 2. See http://www.diodes.com/quality/lead_free.html for more information about Diodes Incorporated's definitions of Halogen- and Antimony-free, "Green" and Lead-free.
 3. Halogen- and Antimony-free "Green" products are defined as those which contain <900ppm bromine, <900ppm chlorine (<1500ppm total Br + Cl) and <1000ppm antimony compounds.

Pin Assignments

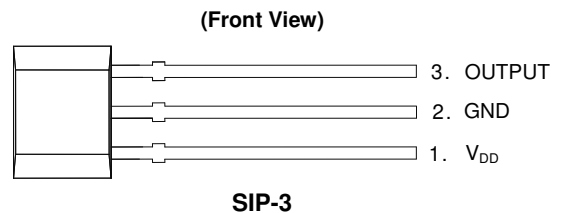
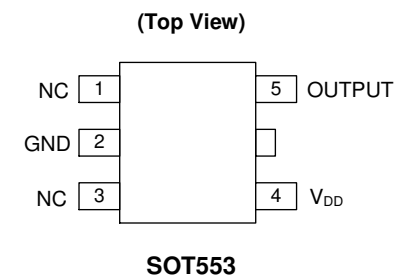
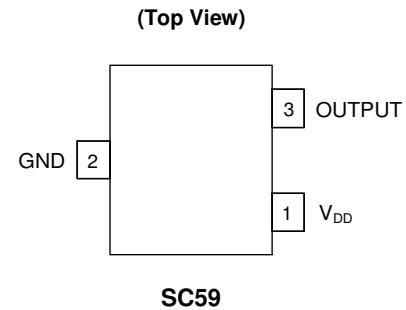

Applications

- Doors, Lids, Covers and Tray Position Detect Switches
- Display Switch for Portable PCs and Tablets
- On/Off Switch for PDAs and Digital Cameras
- Liquid Level Detection for Coffee Machines
- Smart Meters
- Position, Proximity and Level Detection Contactless Switch in Battery Powered Consumer, Home Appliances and Industrial Applications

Typical Applications Circuit (Note 4)

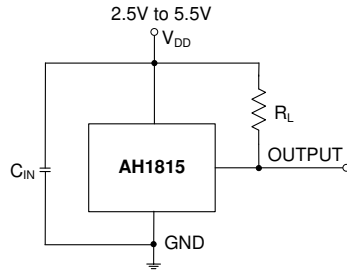

Note: 4. C_{IN} is for power stabilization and to strengthen the noise immunity, the recommended capacitance is 10nF to 100nF.
 R_L is the pull-up resistor, the recommended resistance is 10k Ω to 100k Ω .

Pin Descriptions

Packages: SC59 and SIP-3

Pin Number	Pin Name	Function
1	V _{DD}	Power Supply Input
2	GND	Ground
3	OUTPUT	Output

Package: SOT553

Pin Number	Pin Name	Function
1	NC	No Connection (Note 5)
2	GND	Ground
3	NC	No Connection (Note 5)
4	V _{DD}	Power Supply Input
5	OUTPUT	Output

Note: 5. NC is "No Connection" pin and is not connected internally. This pin can be left open or tied to ground.

Functional Block Diagram

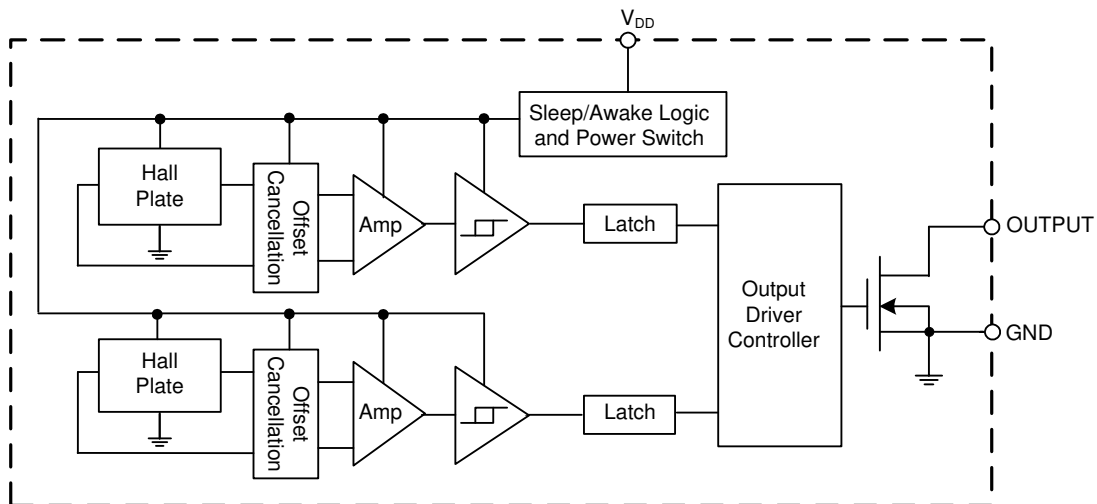

Absolute Maximum Ratings (Note 6) (@ $T_A = +25^\circ\text{C}$, unless otherwise specified.)

Symbol	Parameter	Values	Unit	
V_{DD}	Supply Voltage (Note 7)	7	V	
V_{OUT}	Output Pin Voltage (Note 7)	7	V	
V_{DD_REV}	Reverse Supply Voltage	-0.3	V	
V_{OUT_REV}	Reverse Output Pin Voltage	-0.3	V	
I_{OUTPUT}	Output Current (Source and Sink)	2.5	mA	
B	Magnetic Flux Density	Unlimited		
P_D	Package Power Dissipation	SC59 and SOT553	230	mW
		SIP-3	230	mW
T_{STG}	Storage Temperature Range	-65 to +150	$^\circ\text{C}$	
T_J	Maximum Junction Temperature	+150	$^\circ\text{C}$	
ESD HBM	Human Body Model ESD capability	6	kV	

- Notes:
- Stresses greater than the 'Absolute Maximum Ratings' specified above may cause permanent damage to the device. These are stress ratings only; functional operation of the device at these or any other conditions exceeding those indicated in this specification is not implied. Device reliability may be affected by exposure to absolute maximum rating conditions for extended periods of time.
 - The absolute maximum V_{DD} of 7V is a transient stress rating and is not meant as a functional operating condition. It is not recommended to operate the device at the absolute maximum rated conditions for any period of time.

Recommended Operating Conditions (@ $T_A = +25^\circ\text{C}$, unless otherwise specified.)

Symbol	Characteristic	Conditions	Rating	Unit
V_{DD}	Supply Voltage	Operating	2.5 to 5.5	V
V_{OUT_MAX}	Maximum Output Pin Voltage	Operating	5.5	V
T_A	Operating Temperature Range	Operating	-40 to +125	$^\circ\text{C}$

Electrical Characteristics (@ $T_A = +25^\circ\text{C}$, $V_{DD} = 3\text{V}$, unless otherwise specified.)

Symbol	Characteristic	Conditions	Min	Typ	Max	Unit
V_{OUT_ON}	Output On Voltage	$I_{OUT} = 1\text{mA}$	—	0.1	0.3	V
I_{OFF}	Output Leakage Current	$V_{OUT} = 5.5\text{V}$, Output off	—	< 0.1	1	μA
I_{DD} (Awake)	Supply Current	During awake period, $T_A = +25^\circ\text{C}$, $V_{DD} = 3\text{V}$	—	3	6	mA
		During awake period, $T_A = -40^\circ\text{C}$ to $+125^\circ\text{C}$, $V_{DD} = 2.5\text{V}$ to 5.5V	—	3	12	mA
I_{DD} (Sleep)	Supply Current	During sleep period, $T_A = +25^\circ\text{C}$, $V_{DD} = 3\text{V}$	—	5	10	μA
I_{DD} (Sleep)		During sleep period, $T_A = -40^\circ\text{C}$ to $+125^\circ\text{C}$, $V_{DD} = 2.5\text{V}$ to 5.5V	—	—	28	μA
I_{DD} (Avg.)	Average Supply Current	$T_A = +25^\circ\text{C}$, $V_{DD} = 3\text{V}$	—	8	16	μA
		$T_A = -40^\circ\text{C}$ to $+125^\circ\text{C}$, $V_{DD} = 2.5\text{V}$ to 5.5V	—	—	40	μA
t_{AWAKE}	Awake Time	(Note 8)	—	75	125	μs
t_{PERIOD}	Period	(Note 8)	—	75	125	ms
D.C.	Duty Cycle	—	—	0.1	—	%

- Note: 8. When power is initially turned on, the operating V_{DD} must be within its correct operating range (2.5V to 5.5V) to guarantee the output sampling. The output state is valid after the second operating cycle (typical 150ms).

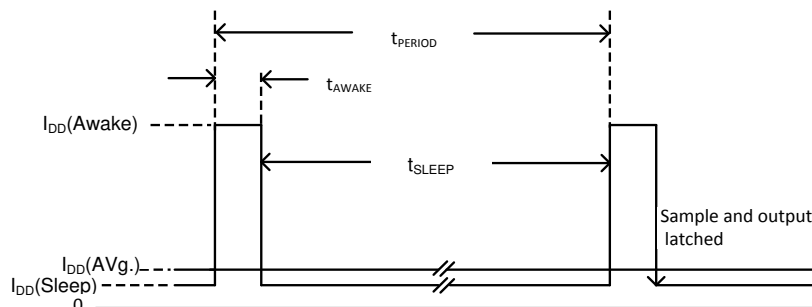

Magnetic Characteristics (Notes 9 & 10) (@ $T_A = -40^\circ\text{C}$ to $+125^\circ\text{C}$, $V_{DD} = 2.5\text{V}$ to 5.5V , unless otherwise specified.)

(1mT=10 Gauss)

Symbol	Characteristic	Conditions	Min	Typ	Max	Unit
Bops (South Pole to Part Marking Side)	Operating Points	$V_{DD} = 2.5\text{V}$ to 5.5V , $T_A = -40^\circ\text{C}$ to $+125^\circ\text{C}$,	255	395	540	Gauss
Bopn (North Pole to Part Marking Side)			-540	-395	-255	
Brps (South Pole to Part Marking Side)	Releasing Points	$V_{DD} = 2.5\text{V}$ to 5.5V , $T_A = -40^\circ\text{C}$ to $+125^\circ\text{C}$,	230	355	490	
Brpn (North Pole to Part Marking Side)			-490	-355	-230	
Bhy ($ B_{opx} - B_{rpx} $)	—	Hysteresis (Note 11)	—	40	—	

- Notes:
- 9. Typical data is at $T_A = +25^\circ\text{C}$, $V_{DD} = 3\text{V}$, and for design information only.
 - 10. Maximum and minimum parameters values over the operating temperature range are not tested in production, they are guaranteed by design, characterization and process control. The magnetic characteristics may vary with supply voltage, operating temperature and after soldering.
 - 11. Maximum and minimum hysteresis is guaranteed by design and characterization.

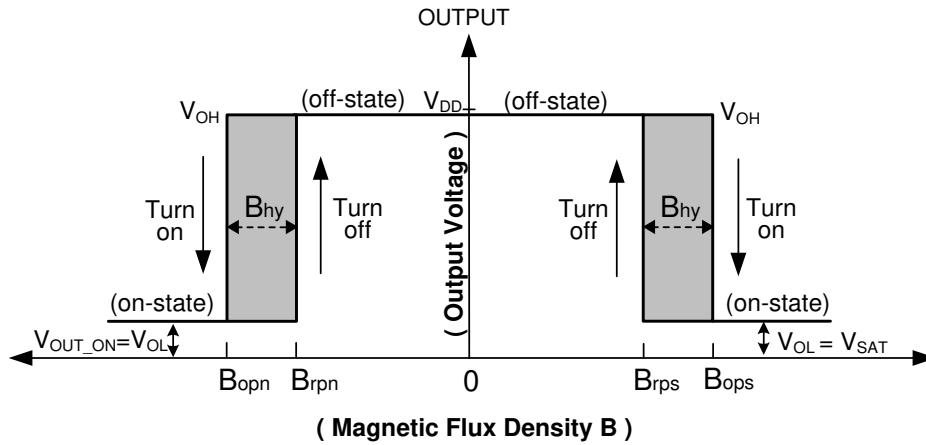

Typical Operating Characteristics

Magnetic Operating Switch Points – Bop and Brp

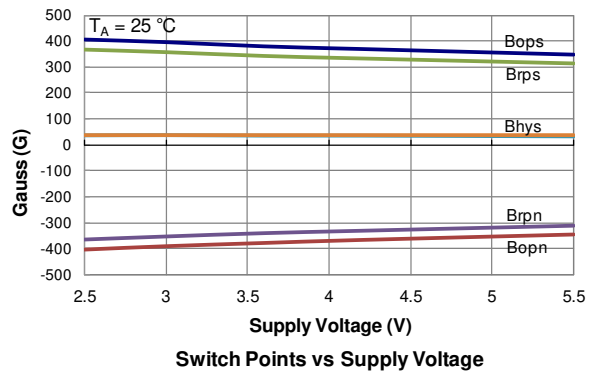
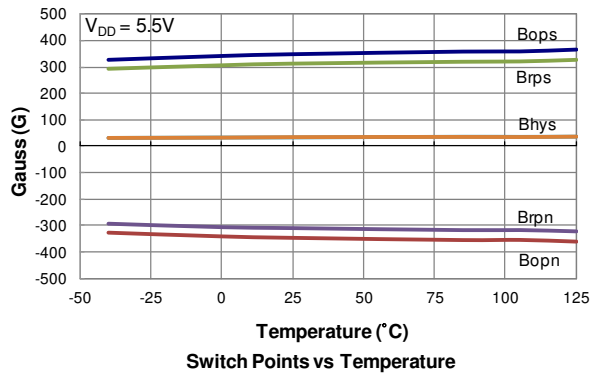
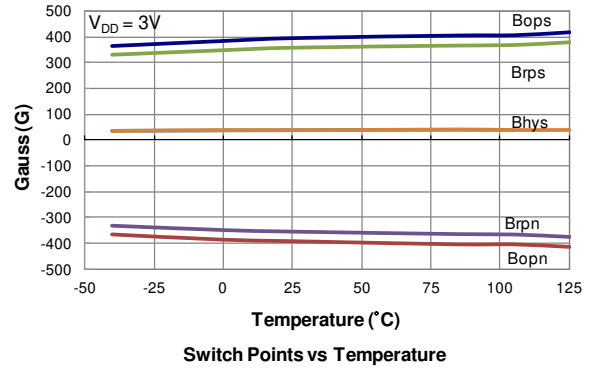
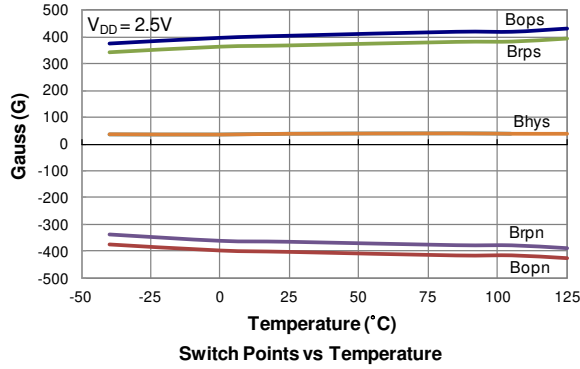

Average Supply Current

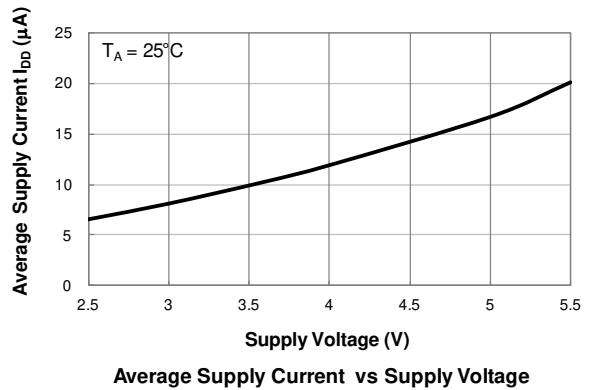
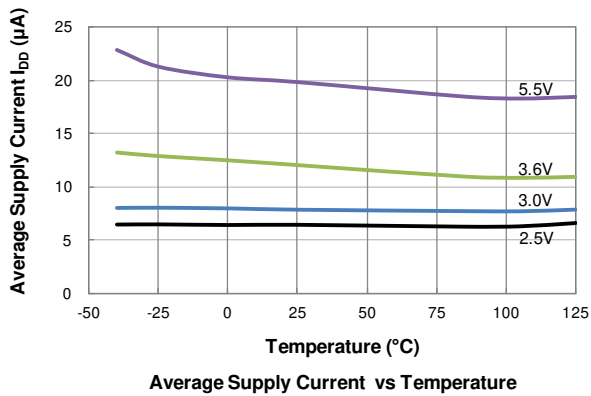

Thermal Performance Characteristics

(1) Package Types: SC59, SOT553 and SIP-3

T _A (°C)	25	50	60	70	80	85	90	100	110	120	130	140	150
P _D (mW)	230	184	166	147	129	120	110	92	74	55	37	18	0

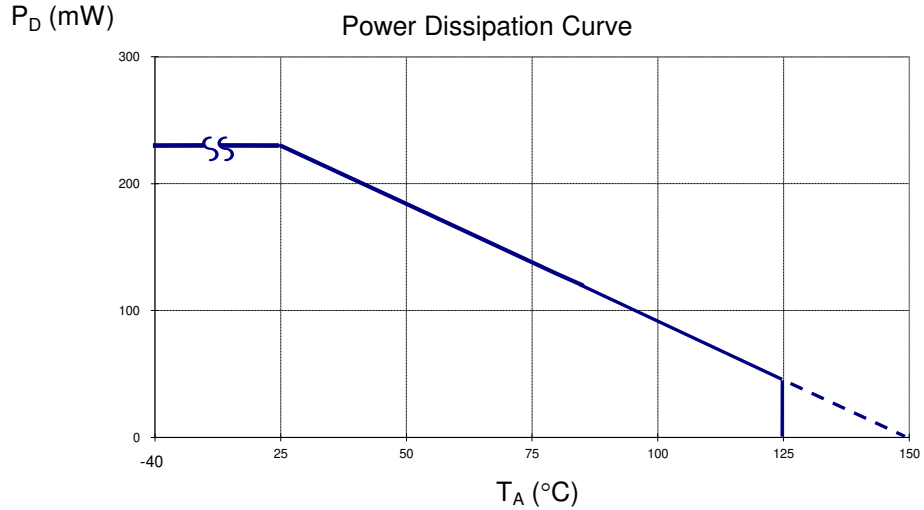

Ordering Information

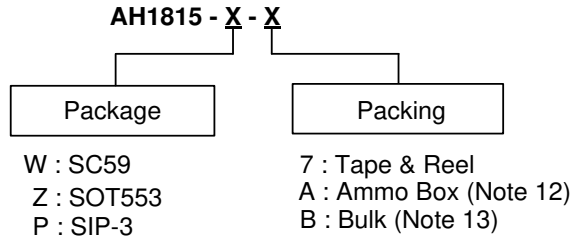

Device	Package Code	Packaging	Bulk		7" Tape and Reel		Ammo Box	
			Quantity	Part Number Suffix	Quantity	Part Number Suffix	Quantity	Part Number Suffix
AH1815-P-A	P	SIP-3	NA	NA	NA	NA	4,000/Box	-A
AH1815-P-B	P	SIP-3	1000	-B	NA	NA	NA	NA
AH1815-W-7	W	SC59	NA	NA	3,000/Tape & Reel	-7	NA	NA
AH1815-Z-7	Z	SOT553	NA	NA	3,000/Tape & Reel	-7	NA	NA

Notes: 12. Ammo Box is for SIP-3 Spread Lead.
13. Bulk is for SIP-3 Straight Lead.

Marking Information

(1) Package Type: SC59

(Top View)

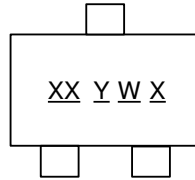

XX : Identification Code
Y : Year 0 to 9
W : Week : A to Z : 1 to 26 week;
a to z : 27 to 52 week; z represents
52 and 53 week
X : Internal Code

Part Number	Package	Identification Code
AH1815	SC59	AG

(2) Package Type: SOT553

(Top View)

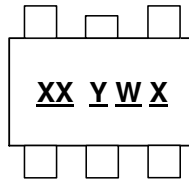

XX : Identification Code
Y : Year : 0 to 9
W : Week : A to Z : 1~26 week;
a to z : 27~52 week; z represents
52 and 53 week
X : Internal code

Part Number	Package	Identification Code
AH1815	SOT553	AG

(3) Package Type: SIP-3

(Front View)

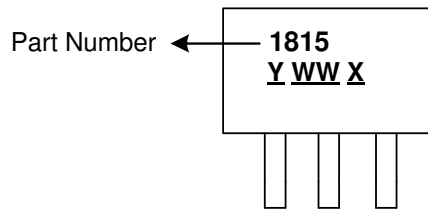

Y : Year : 0 to 9
WW : Week : 01~52, "52" represents
52 and 53 week
X : Internal Code

Package Outline Dimensions (All dimensions in mm.)

Please see AP02002 at <http://www.diodes.com/datasheets/ap02002.pdf> for the latest version.

(1) Package Type: SC59

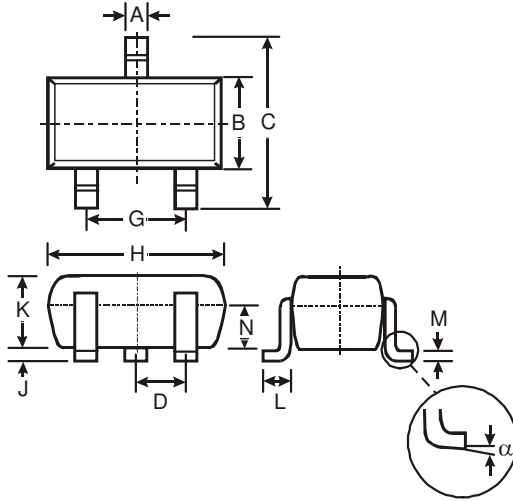

SC59			
Dim	Min	Max	Typ
A	0.35	0.50	0.38
B	1.50	1.70	1.60
C	2.70	3.00	2.80
D	-	-	0.95
G	-	-	1.90
H	2.90	3.10	3.00
J	0.013	0.10	0.05
K	1.00	1.30	1.10
L	0.35	0.55	0.40
M	0.10	0.20	0.15
N	0.70	0.80	0.75
α	0°	8°	-
All Dimensions in mm			

Min/Max

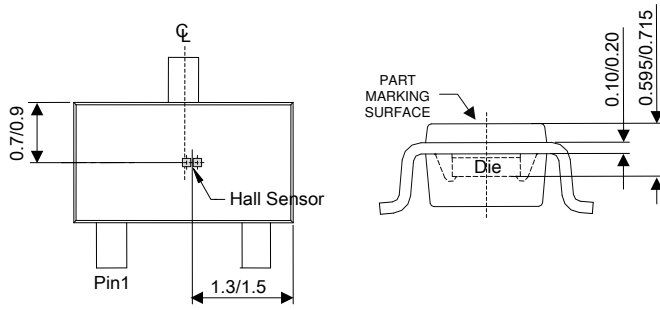

Sensor Location

Package Outline Dimensions (cont.) (All dimensions in mm.)

Please see AP02002 at <http://www.diodes.com/datasheets/ap02002.pdf> for the latest version.

(2) Package Type: SOT553

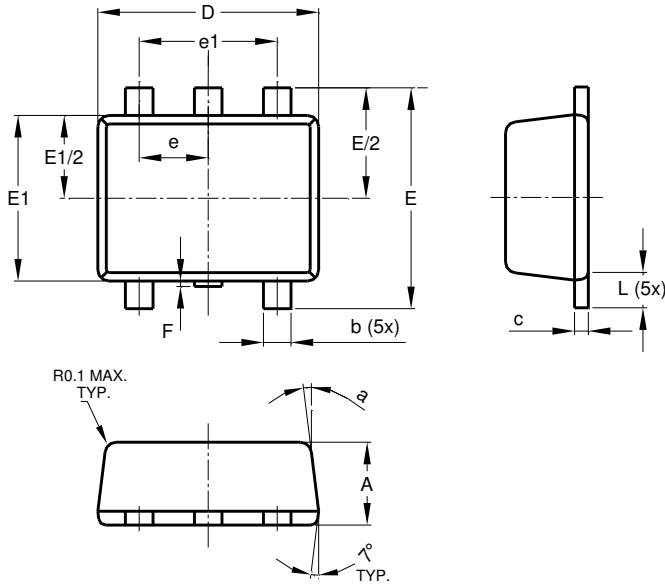

SOT553			
Dim	Min	Max	Typ
A	0.55	0.62	0.60
b	0.15	0.30	0.20
c	0.10	0.18	0.15
D	1.50	1.70	1.60
E	1.55	1.70	1.60
E1	1.10	1.25	1.20
e	0.50 BSC		
e1	1.00 BSC		
F	0.00	0.10	—
L	0.10	0.30	0.20
a	6°	8°	7°
All Dimensions in mm			

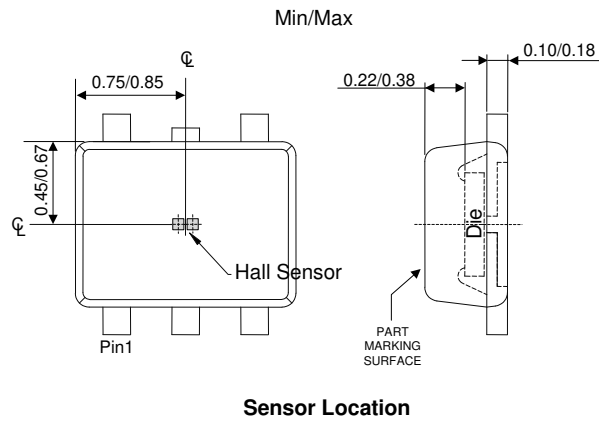

Package Outline Dimensions (cont.) (All dimensions in mm.)

Please see AP02002 at <http://www.diodes.com/datasheets/ap02002.pdf> for the latest version.

(3) Package Type: SIP-3 (Bulk Pack)

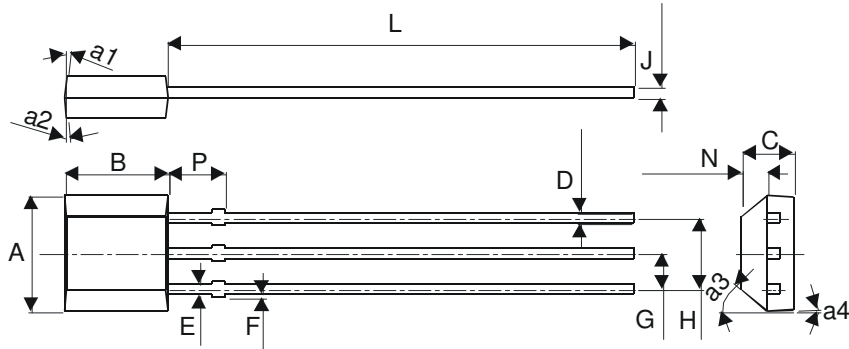

SIP-3 (Bulk Pack)		
Dim	Min	Max
A	3.9	4.3
a1	5° Typ	
a2	5° Typ	
a3	45° Typ	
a4	3° Typ	
B	2.8	3.2
C	1.40	1.60
D	0.33	0.432
E	0.40	0.508
F	0	0.2
G	1.24	1.30
H	2.51	2.57
J	0.35	0.43
L	14.0	15.0
N	0.63	0.84
P	1.55	-
All Dimensions in mm		

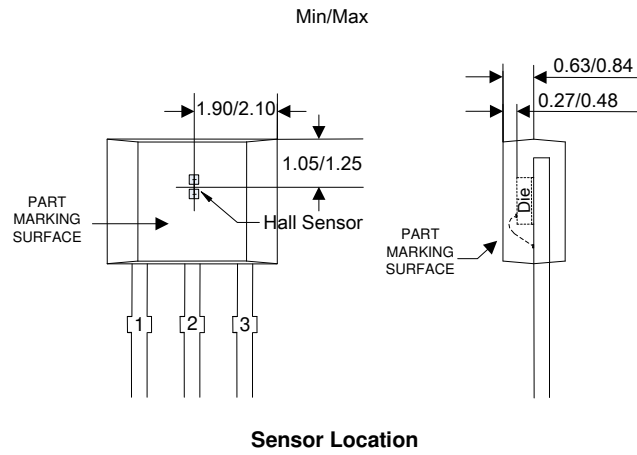

Sensor Location

Package Outline Dimensions (cont.) (All dimensions in mm.)

Please see AP02002 at <http://www.diodes.com/datasheets/ap02002.pdf> for the latest version.

(4) Package Type: SIP-3 (Ammo Pack)

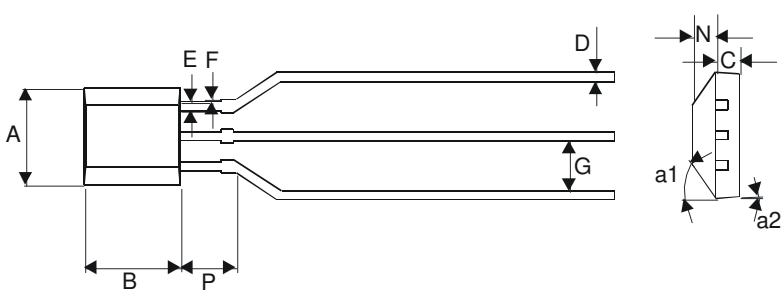

SIP-3 (Ammo Pack)		
Dim	Min	Max
A	3.9	4.3
a1	45° Typ	
a2	3° Typ	
B	2.8	3.2
C	1.40	1.60
D	0.35	0.41
E	0.43	0.48
F	0	0.2
G	2.4	2.9
N	0.63	0.84
P	1.55	-
All Dimensions in mm		

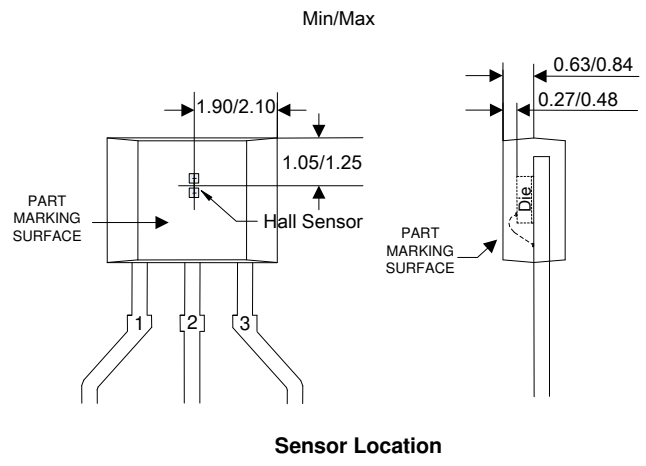

Suggested Pad Layout

Please see AP02001 at <http://www.diodes.com/datasheets/ap02001.pdf> for the latest version.

(1) Package Type: SC59

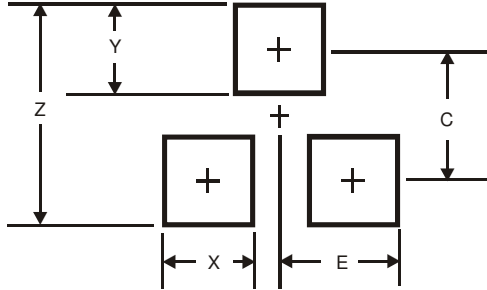

Dimensions	Value (in mm)
Z	3.4
X	0.8
Y	1.0
C	2.4
E	1.35

(2) Package Type: SOT553

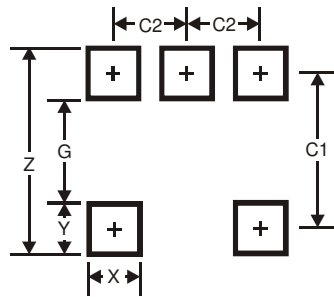

Dimensions	Value (in mm)
Z	2.2
G	1.2
X	0.375
Y	0.5
C1	1.7
C2	0.5

IMPORTANT NOTICE

DIODES INCORPORATED MAKES NO WARRANTY OF ANY KIND, EXPRESS OR IMPLIED, WITH REGARDS TO THIS DOCUMENT, INCLUDING, BUT NOT LIMITED TO, THE IMPLIED WARRANTIES OF MERCHANTABILITY AND FITNESS FOR A PARTICULAR PURPOSE (AND THEIR EQUIVALENTS UNDER THE LAWS OF ANY JURISDICTION).

Diodes Incorporated and its subsidiaries reserve the right to make modifications, enhancements, improvements, corrections or other changes without further notice to this document and any product described herein. Diodes Incorporated does not assume any liability arising out of the application or use of this document or any product described herein; neither does Diodes Incorporated convey any license under its patent or trademark rights, nor the rights of others. Any Customer or user of this document or products described herein in such applications shall assume all risks of such use and will agree to hold Diodes Incorporated and all the companies whose products are represented on Diodes Incorporated website, harmless against all damages.

Diodes Incorporated does not warrant or accept any liability whatsoever in respect of any products purchased through unauthorized sales channel. Should Customers purchase or use Diodes Incorporated products for any unintended or unauthorized application, Customers shall indemnify and hold Diodes Incorporated and its representatives harmless against all claims, damages, expenses, and attorney fees arising out of, directly or indirectly, any claim of personal injury or death associated with such unintended or unauthorized application.

Products described herein may be covered by one or more United States, international or foreign patents pending. Product names and markings noted herein may also be covered by one or more United States, international or foreign trademarks.

This document is written in English but may be translated into multiple languages for reference. Only the English version of this document is the final and determinative format released by Diodes Incorporated.

LIFE SUPPORT

Diodes Incorporated products are specifically not authorized for use as critical components in life support devices or systems without the express written approval of the Chief Executive Officer of Diodes Incorporated. As used herein:

A. Life support devices or systems are devices or systems which:

1. are intended to implant into the body, or
2. support or sustain life and whose failure to perform when properly used in accordance with instructions for use provided in the labeling can be reasonably expected to result in significant injury to the user.

B. A critical component is any component in a life support device or system whose failure to perform can be reasonably expected to cause the failure of the life support device or to affect its safety or effectiveness.

Customers represent that they have all necessary expertise in the safety and regulatory ramifications of their life support devices or systems, and acknowledge and agree that they are solely responsible for all legal, regulatory and safety-related requirements concerning their products and any use of Diodes Incorporated products in such safety-critical, life support devices or systems, notwithstanding any devices- or systems-related information or support that may be provided by Diodes Incorporated. Further, Customers must fully indemnify Diodes Incorporated and its representatives against any damages arising out of the use of Diodes Incorporated products in such safety-critical, life support devices or systems.

Copyright © 2015, Diodes Incorporated

www.diodes.com