



Chipsmall Limited consists of a professional team with an average of over 10 year of expertise in the distribution of electronic components. Based in Hongkong, we have already established firm and mutual-benefit business relationships with customers from,Europe,America and south Asia,supplying obsolete and hard-to-find components to meet their specific needs.

With the principle of “Quality Parts,Customers Priority,Honest Operation,and Considerate Service”,our business mainly focus on the distribution of electronic components. Line cards we deal with include Microchip,ALPS,ROHM,Xilinx,Pulse,ON,Everlight and Freescale. Main products comprise IC,Modules,Potentiometer,IC Socket,Relay,Connector.Our parts cover such applications as commercial,industrial, and automotives areas.

We are looking forward to setting up business relationship with you and hope to provide you with the best service and solution. Let us make a better world for our industry!



Contact us

Tel: +86-755-8981 8866 Fax: +86-755-8427 6832

Email & Skype: info@chipsmall.com Web: www.chipsmall.com

Address: A1208, Overseas Decoration Building, #122 Zhenhua RD., Futian, Shenzhen, China



Description

The AH9249 is an ultra-sensitive Hall-effect switch with digital latched output, mainly designed for battery-operation, hand-held equipments.

Special CMOS process is used for low-voltage and low-power requirement. A chopper stabilized amplifier improves stability of magnetic switch points. A sleep-awake logic controls the IC in sleep time or awake time. This function will reduce the average operating current of the IC. During the awake time, the output is changed with the magnetic flux density. During the sleep time, the output is latched in its previous state and the current consumption will reduce to some μA .

The IC switching behaviour is omnipolar, either north or south pole sufficient strength will turn the output on. If the magnetic flux density is larger than operating point (B_{OP}), the output will be turned on; if it is less than releasing point (B_{RP}), the output will be turned off.

The AH9249 is available in TO-92S-3, SOT-23-3 and DFN-2x2-3 packages which are optimized for most applications.

Features

- Micropower Operation
- 2.5V to 5.5V Power Supply
- Switching for Both Poles of a Magnet (Omnipolar)
- Stabilized Chopper
- Superior Temperature Stability
- Digital Output Signal
- Built-in Pull-up Resistor
- ESD Rating: 4000V (Human Body Model)
600V (Machine Model)
- **Totally Lead-Free & Fully RoHS Compliant (Notes 1 & 2)**
- **Halogen and Antimony Free. "Green" Device (Note 3)**

- Notes:
1. No purposely added lead. Fully EU Directive 2002/95/EC (RoHS) & 2011/65/EU (RoHS 2) compliant.
 2. See http://www.diodes.com/quality/lead_free.html for more information about Diodes Incorporated's definitions of Halogen- and Antimony-free, "Green" and Lead-free.
 3. Halogen- and Antimony-free "Green" products are defined as those which contain <900ppm bromine, <900ppm chlorine (<1500ppm total Br + Cl) and <1000ppm antimony compounds.

Pin Assignments

(Front View)

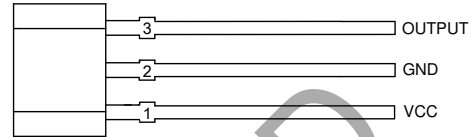

TO-92S-3

(Top View)

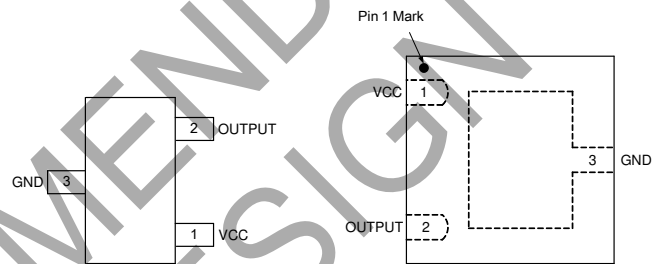

SOT-23-3

DFN-2x2-3

Applications

- Cover Switch in Notebook PC/PDA
- Handheld Wireless Application Awake Switch
- Magnet Switch in Low Duty Cycle Applications

Typical Applications Circuit

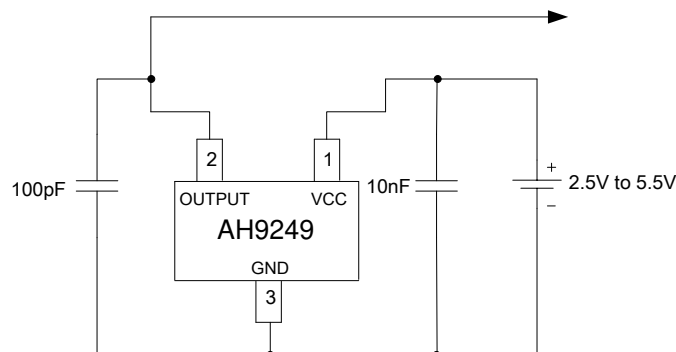

Pin Descriptions

Pin Number			Pin Name	Function
TO-92S-3	SOT-23-3	DFN-2x2-3		
1	1	1	VCC	Power supply pin
2	3	3	GND	Ground pin
3	2	2	OUTPUT	Output pin

Functional Block Diagram

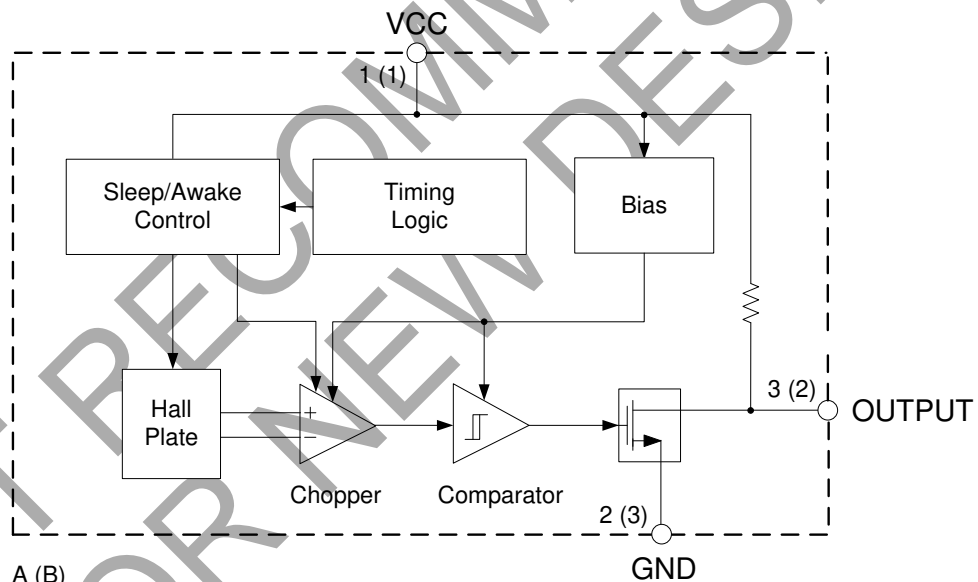

A (B)
A for TO-92S-3
B for SOT-23-3 and DFN-2x2-3

Absolute Maximum Ratings (@ $T_A=+25^\circ\text{C}$, Note 4)

Symbol	Parameter	Rating	Unit
V_{CC}	Supply Voltage	7	V
I_{CC}	Supply Current (Fault)	6	mA
V_{OUT}	Output Voltage	7	V
I_{OUT}	Output Current	2	mA
B	Magnetic Flux Density	Unlimited	Gauss
P_D	Power Dissipation	TO-92S-3	400
		SOT-23-3	230
		DFN-2x2-3	230
T_{STG}	Storage Temperature	-55 to +150	$^\circ\text{C}$
T_J	Junction Temperature	+150	$^\circ\text{C}$
—	ESD (Human Body Model) (Note 5)	4000	V
—	ESD (Machine Model) (Note 5)	600	

Notes: 4. Stresses greater than those listed under "Absolute Maximum Ratings" may cause permanent damage to the device. These are stress ratings only, and functional operation of the device at these or any other conditions beyond those indicated under "Recommended Operating Conditions" is not implied. Exposure to "Absolute Maximum Ratings" for extended periods may affect device reliability..
5. Electronic semiconductor products are sensitive to Electro Static Discharge (ESD). Always observe Electro Static Discharge control procedures whenever handling semiconductor products.

Recommended Operating Conditions

Symbol	Parameter	Min	Max	Unit
V_{CC}	Supply Voltage	2.5	5.5	V
T_{OP}	Operating Temperature	-40	+85	$^\circ\text{C}$

Electrical Characteristics (@ $T_A=+25^\circ\text{C}$, $V_{CC}=3\text{V}$, unless otherwise specified.)

Symbol	Parameter	Conditions	Min	Typ	Max	Unit
V_{CC}	Supply Voltage	Operating	2.5	3	5.5	V
I_{AW}	Supply Current	Awake	—	2	4	mA
I_{SL}		Sleep	—	6	10	μA
I_{AVG}		Average	—	10	15	μA
I_{OUT}	Output Current	—	—	—	1.0	mA
I_{LEAK}	Output Leakage Current	$B < B_{RP} $	—	<0.1	1	μA
V_{SAT}	Saturation Voltage	$I_{OUT} = 1.0\text{mA}$	—	—	0.4	V
t_{AW}	Awake Mode Time	Operating	—	150	—	μs
t_{SL}	Sleep Mode Time	Operating	—	90	120	ms
D	Duty Cycle	—	—	0.15	—	%
f_C	Chopper Frequency	—	—	15	—	kHz

Magnetic Characteristics (@ $T_A=+25^{\circ}\text{C}$, $V_{CC}=3\text{V}$, unless otherwise specified. Note 6)

Symbol	Parameter	Conditions	Min	Typ	Max	Unit
B_{OPS}	Operating Point	South pole to branded side $B > B_{OPS}, V_{OUT} = \text{low}$ (output on)	—	30	55	Gauss
B_{OPN}		North pole to branded side $B > B_{OPN}, V_{OUT} = \text{low}$ (output on)	-55	-30	—	Gauss
B_{RPS}	Releasing Point	South pole to branded side $B < B_{RPS}, V_{OUT} = \text{high}$ (output off)	5	20	—	Gauss
B_{RPN}		North pole to branded side $B < B_{RPN}, V_{OUT} = \text{high}$ (output off)	—	-20	-5	Gauss
B_{HYS}	Hysteresis	$ B_{OPX} - B_{RPX} $ (Note 7)	—	10	—	Gauss

- Notes: 6. The specifications stated here are guaranteed by design. 1 Gauss=0.1mT
7. B_{OPX} =operating point (output turns on); B_{RPX} =releasing point (output turns off)

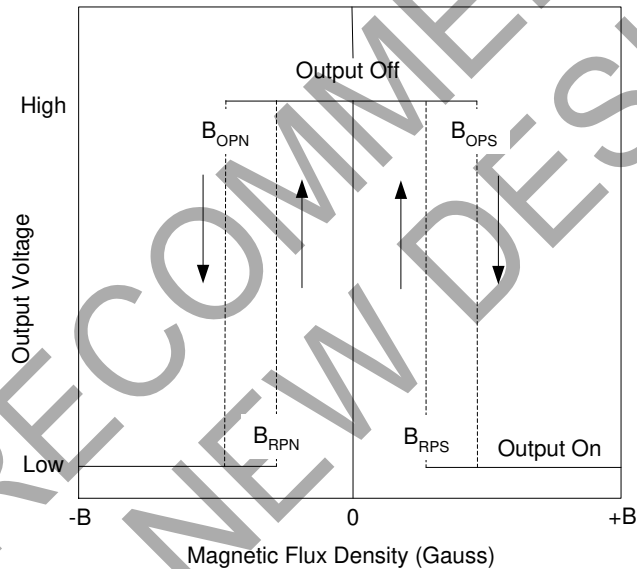

Output Voltage vs. Magnetic Flux Density

Test Conditions

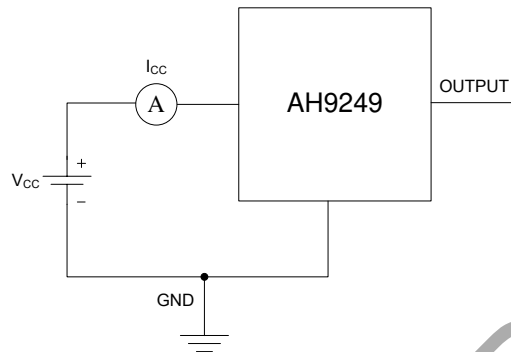

Average Supply Current (Note 8, Note 9)

Note 8: I_{CC} represents the average supply current. OUTPUT is open during measurement.
 Note 9: The device is put under magnetic field with $B < B_{RP}$.

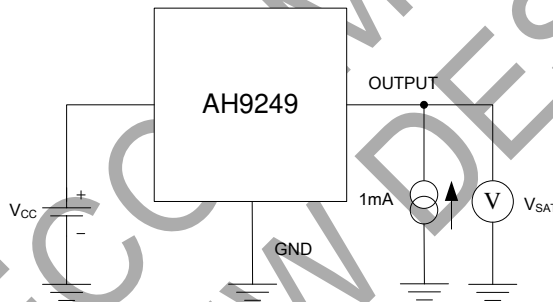

Output Saturation Voltage (Note 10, Note 11)

Note 10: The output saturation voltage V_{SAT} is measured at $V_{CC}=2.5V$ and $V_{CC}=5.5V$.
 Note 11: The device is put under magnetic field with $B > B_{OP}$.

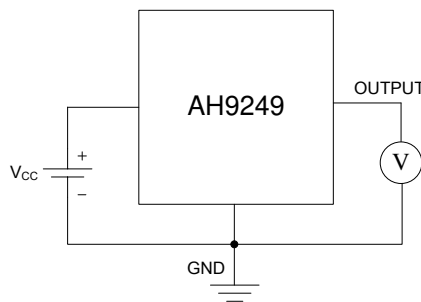

Magnetic Thresholds (Note 12, Note 13)

Note 12: B_{OP} is determined by putting the device under magnetic field swept from $B_{RP}(\min)$ to $B_{OP}(\max)$ until the output is switched on.
 Note 13: B_{RP} is determined by putting the device under magnetic field swept from $B_{OP}(\max)$ to $B_{RP}(\min)$ until the output is switched off.

Performance Characteristics

B_{OP}/B_{RP} vs. Supply Voltage

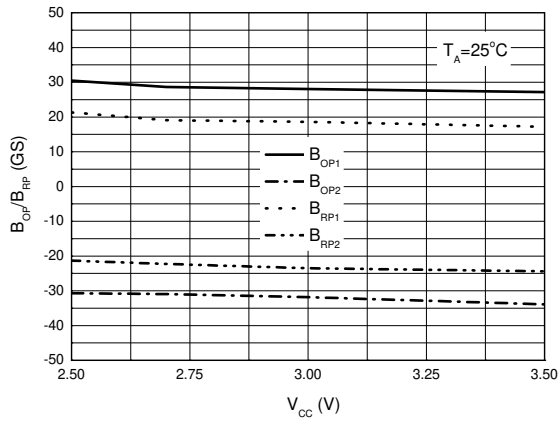

B_{OP}/B_{RP} vs. Ambient Temperature

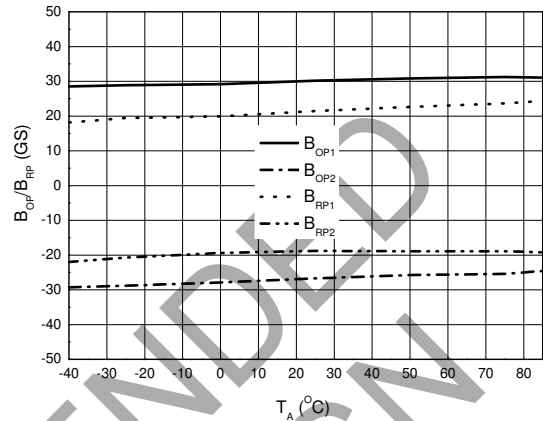

Average Supply Current vs. Supply Voltage

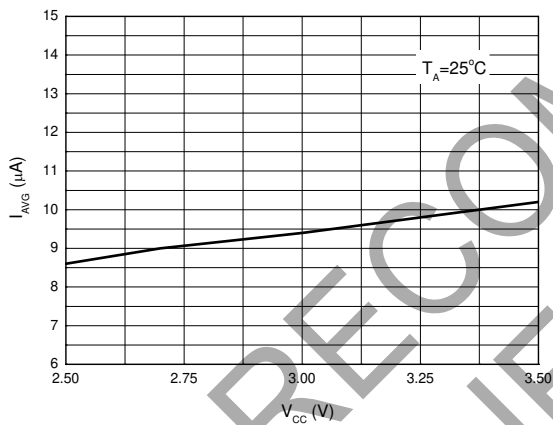

Awake Mode Time vs. Supply Voltage

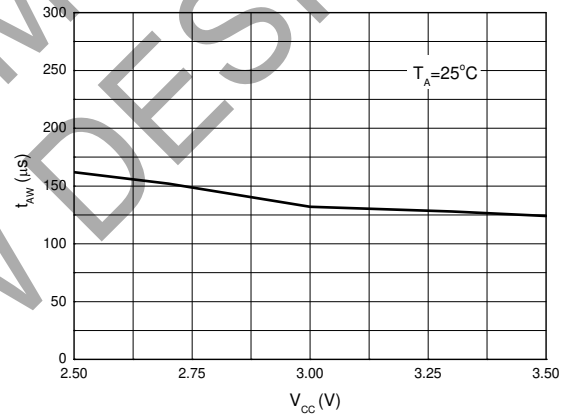

Sleep Mode Time vs. Supply Voltage

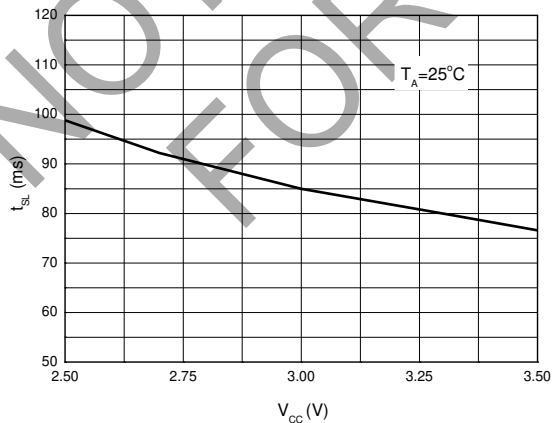

Power Dissipation vs. Ambient Temperature

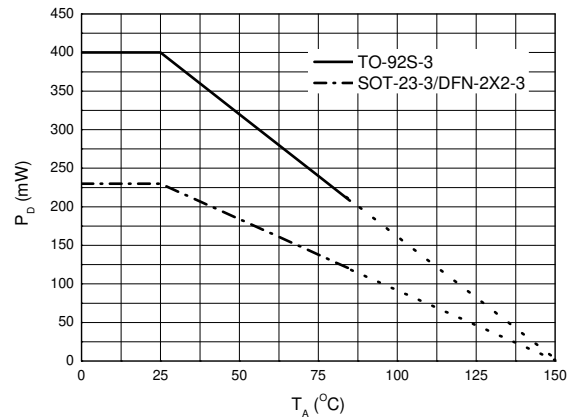

Ordering Information

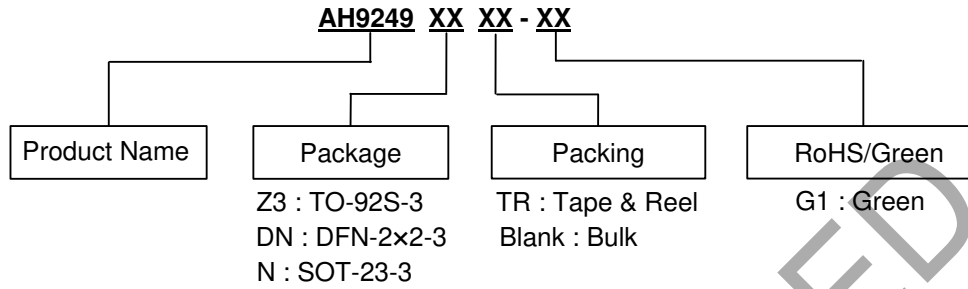

Device	Status(Note 14)	Package Code	Packaging	Bulk	7" Tape and Reel
				Quantity	Quantity
AH9249Z3-G1	NRND	Z3	TO-92S-3	1000/Bulk	NA
AH9249DNTR-G1	NRND	DN	DFN-2X2-3	NA	3000/Tape & Reel
AH9249NTR-G1	NRND	N	SOT-23-3	NA	3000/Tape & Reel

Note 14: NRND = Not Recommended for New Design.

NOT RECOMMENDED FOR NEW DESIGN

Marking Information

(1) Package Type: TO-92S-3

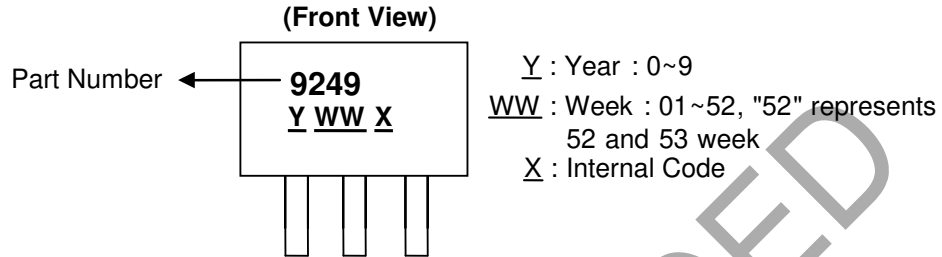

Part Number	Package	Identification Code
AH9249	TO-92S-3	9249

(2) Package Type: SOT-23-3

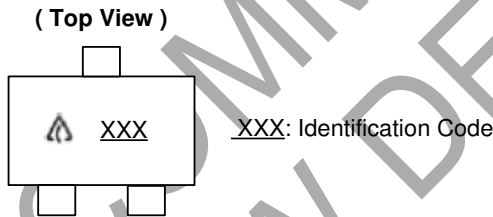

Part Number	Package	Identification Code
AH9249	SOT-23-3	GJ9

(3) Package Type: DFN-2X2-3

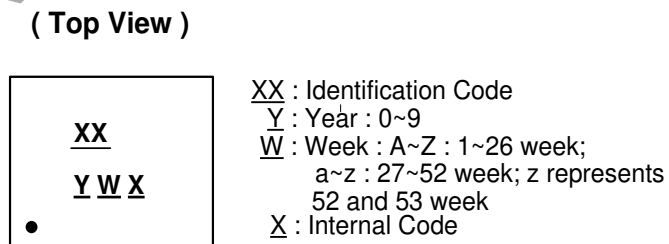

Part Number	Package	Identification Code
AH9249	DFN-2X2-3	JB

Package Outline Dimensions (All dimensions in mm(inch).)

(1) Package Type: TO-92S-3

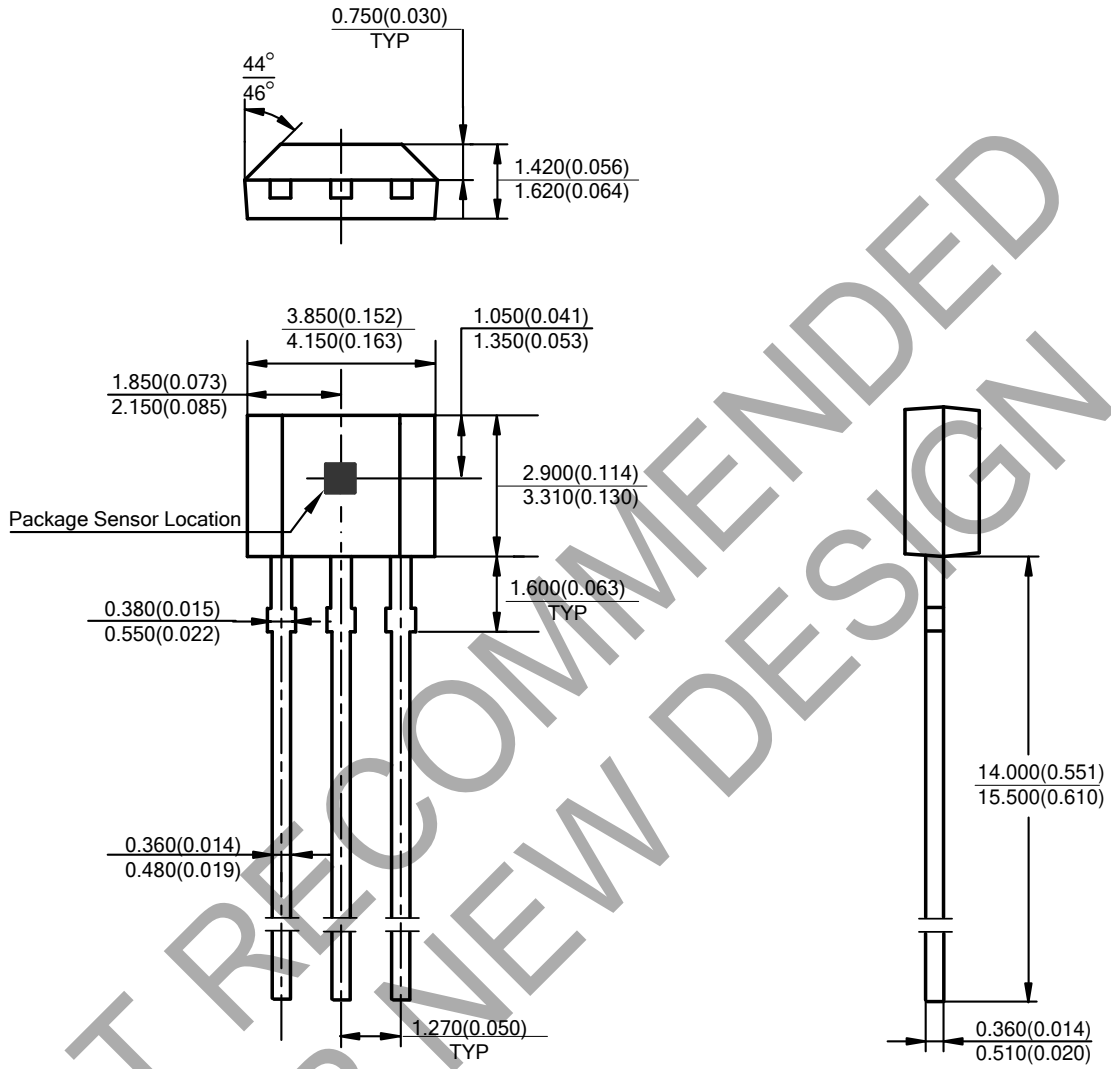

Package Outline Dimensions (cont.) (All dimensions in mm(inch).)

(2) Package Type: SOT-23-3

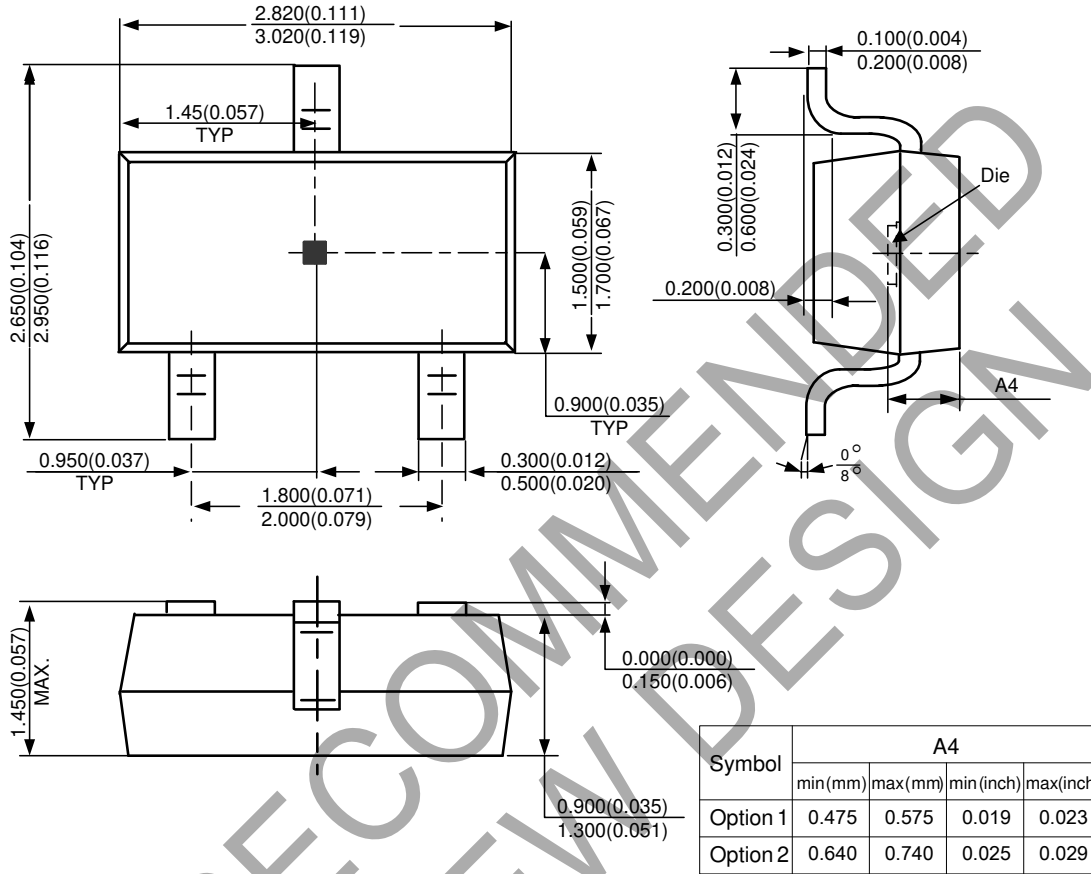

NOT RECOMMENDED FOR NEW DESIGN

Package Outline Dimensions (cont.) (All dimensions in mm(inch).)

(3) Package Type: DFN-2x2-3

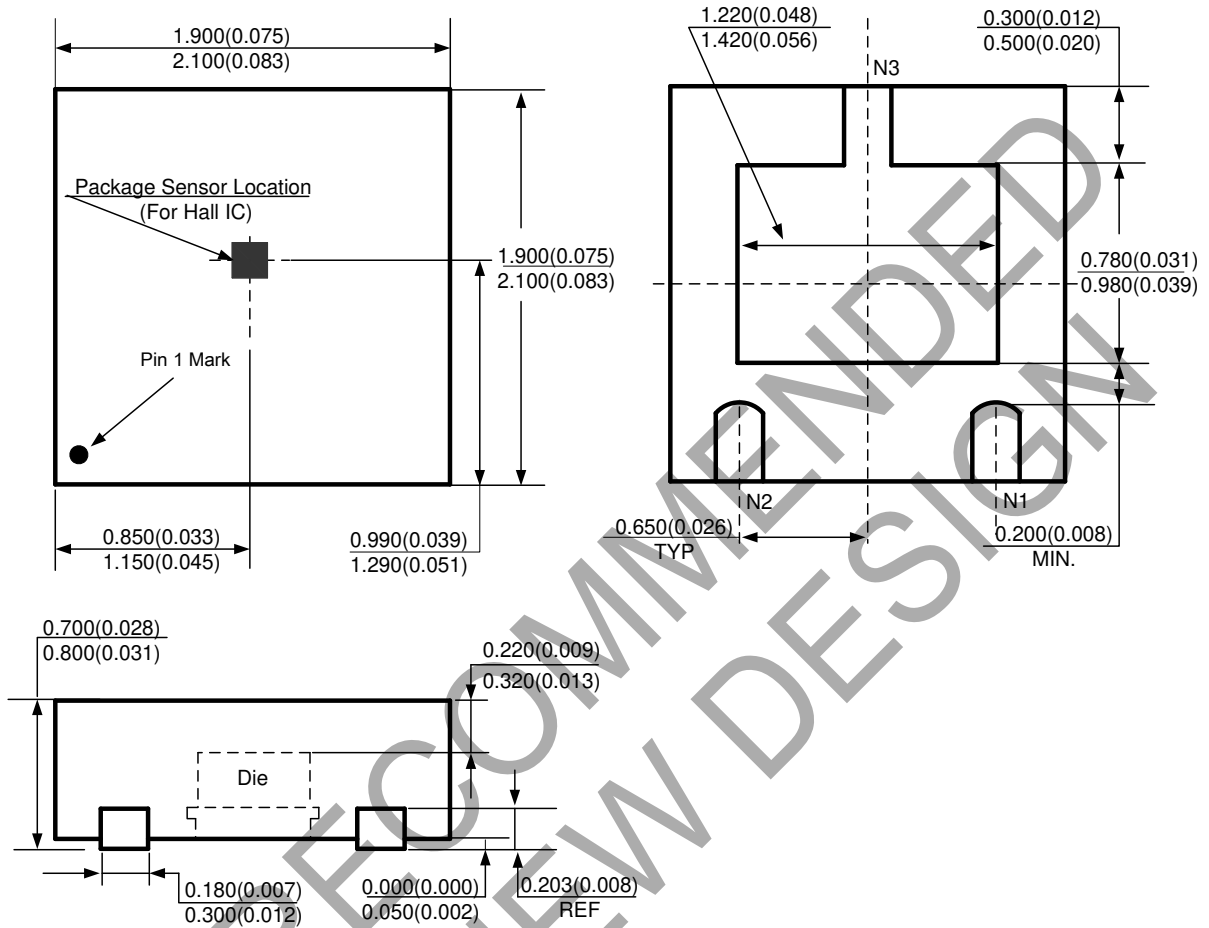

Suggested Pad Layout

(1) Package Type: SOT-23-3

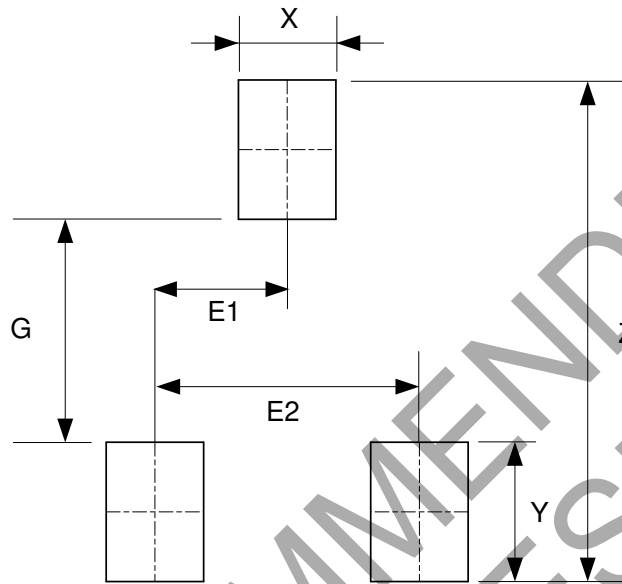

Dimensions	Z (mm)/(inch)	G (mm)/(inch)	X (mm)/(inch)	Y (mm)/(inch)	E1 (mm)/(inch)	E2 (mm)/(inch)
Value	3.600/0.142	1.600/0.063	0.700/0.028	1.000/0.039	0.950/0.037	1.900/0.075

NOT RECOMMENDED FOR NEW DESIGN

Suggested Pad Layout (cont.)

(2) Package Type: DFN-2x2-3

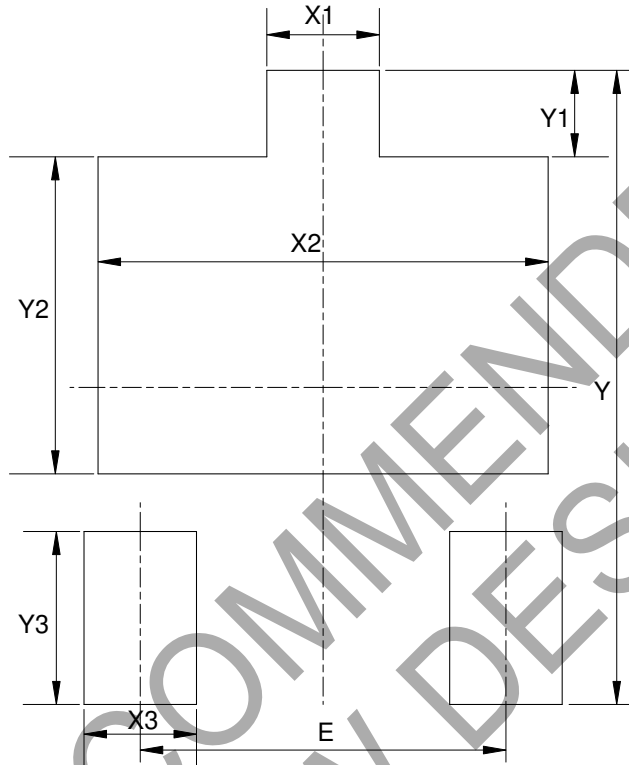

Dimensions	Y (mm)/(inch)	X1=X3 (mm)/(inch)	Y1 (mm)/(inch)	X2 (mm)/(inch)	Y2 (mm)/(inch)	Y3 (mm)/(inch)	E (mm)/(inch)
Value	2.200/0.087	0.400/0.016	0.300/0.012	1.600/0.063	1.100/0.043	0.600/0.024	1.300/0.051

IMPORTANT NOTICE

DIODES INCORPORATED MAKES NO WARRANTY OF ANY KIND, EXPRESS OR IMPLIED, WITH REGARDS TO THIS DOCUMENT, INCLUDING, BUT NOT LIMITED TO, THE IMPLIED WARRANTIES OF MERCHANTABILITY AND FITNESS FOR A PARTICULAR PURPOSE (AND THEIR EQUIVALENTS UNDER THE LAWS OF ANY JURISDICTION).

Diodes Incorporated and its subsidiaries reserve the right to make modifications, enhancements, improvements, corrections or other changes without further notice to this document and any product described herein. Diodes Incorporated does not assume any liability arising out of the application or use of this document or any product described herein; neither does Diodes Incorporated convey any license under its patent or trademark rights, nor the rights of others. Any Customer or user of this document or products described herein in such applications shall assume all risks of such use and will agree to hold Diodes Incorporated and all the companies whose products are represented on Diodes Incorporated website, harmless against all damages.

Diodes Incorporated does not warrant or accept any liability whatsoever in respect of any products purchased through unauthorized sales channel. Should Customers purchase or use Diodes Incorporated products for any unintended or unauthorized application, Customers shall indemnify and hold Diodes Incorporated and its representatives harmless against all claims, damages, expenses, and attorney fees arising out of, directly or indirectly, any claim of personal injury or death associated with such unintended or unauthorized application.

Products described herein may be covered by one or more United States, international or foreign patents pending. Product names and markings noted herein may also be covered by one or more United States, international or foreign trademarks.

This document is written in English but may be translated into multiple languages for reference. Only the English version of this document is the final and determinative format released by Diodes Incorporated.

LIFE SUPPORT

Diodes Incorporated products are specifically not authorized for use as critical components in life support devices or systems without the express written approval of the Chief Executive Officer of Diodes Incorporated. As used herein:

A. Life support devices or systems are devices or systems which:

1. are intended to implant into the body, or
2. support or sustain life and whose failure to perform when properly used in accordance with instructions for use provided in the labeling can be reasonably expected to result in significant injury to the user.

B. A critical component is any component in a life support device or system whose failure to perform can be reasonably expected to cause the failure of the life support device or to affect its safety or effectiveness.

Customers represent that they have all necessary expertise in the safety and regulatory ramifications of their life support devices or systems, and acknowledge and agree that they are solely responsible for all legal, regulatory and safety-related requirements concerning their products and any use of Diodes Incorporated products in such safety-critical, life support devices or systems, notwithstanding any devices- or systems-related information or support that may be provided by Diodes Incorporated. Further, Customers must fully indemnify Diodes Incorporated and its representatives against any damages arising out of the use of Diodes Incorporated products in such safety-critical, life support devices or systems.

Copyright © 2017, Diodes Incorporated

www.diodes.com