



Chipsmall Limited consists of a professional team with an average of over 10 year of expertise in the distribution of electronic components. Based in Hongkong, we have already established firm and mutual-benefit business relationships with customers from,Europe,America and south Asia,supplying obsolete and hard-to-find components to meet their specific needs.

With the principle of “Quality Parts,Customers Priority,Honest Operation,and Considerate Service”,our business mainly focus on the distribution of electronic components. Line cards we deal with include Microchip,ALPS,ROHM,Xilinx,Pulse,ON,Everlight and Freescale. Main products comprise IC,Modules,Potentiometer,IC Socket,Relay,Connector.Our parts cover such applications as commercial,industrial, and automotives areas.

We are looking forward to setting up business relationship with you and hope to provide you with the best service and solution. Let us make a better world for our industry!



Contact us

Tel: +86-755-8981 8866 Fax: +86-755-8427 6832

Email & Skype: info@chipsmall.com Web: www.chipsmall.com

Address: A1208, Overseas Decoration Building, #122 Zhenhua RD., Futian, Shenzhen, China



Single Phase Low Noise Smart Motor Driver

AH9479/80/81

General Description

The AH9479/80/81 is a single chip solution for driving single coil brushless DC motors. It combines a motor driver with a high sensitivity Hall sensor, which simplifies the PCB design and makes the fabrication of small-size motors possible.

The AH9480 has an open-drain tachometer output FG that follows the Hall sensor latching output. The AH9481 has an open-drain rotation detection output RD that is active low when the motor is spinning and goes high when blocked.

When there is no motion about 0.4 second, the IC will automatically detect the locked rotor conditions, and enter protection mode, shutting off the motor driver for 4 seconds. Then, the IC will turn on the motor driver for 0.4 second to detect whether there is rotation condition, if fails, the IC will shut off motor driver for four seconds again. This sequence will be repeated until rotation condition is detected, and the IC enters normal operation. This feature can effectively prevent the IC from overheating and damage due to long-time locked rotor condition. “Soft-switch” is used to reduce the vibration and acoustic noise. Thermal-shutdown protection ensures that the motor driver operates under specified temperature ranges.

The AH9479 is packaged in TO-94, and the AH9480/81 is packaged in TO-95 and MSOP-8.

Features

- Full Bridge Driver
- High Sensitivity Integrated Hall Sensor
- Soft-switching for Low Noise
- Low Supply Voltage: 2.5V
- Locked Rotor Protection and Auto-restart
- Thermal Protection
- Output Over-current Protection
- Short Circuit Protection
- Tachometer Output Signal (AH9480)
- Alarm Output Signal (AH9481)

Applications

- 5V/12V Low Noise BLDC Cooling Fans
- Low Voltage / Low Power BLDC Motors
- Notebook DC Fans / Blowers
- Automotive Low Noise Climate Control Fans
- Micro-motors

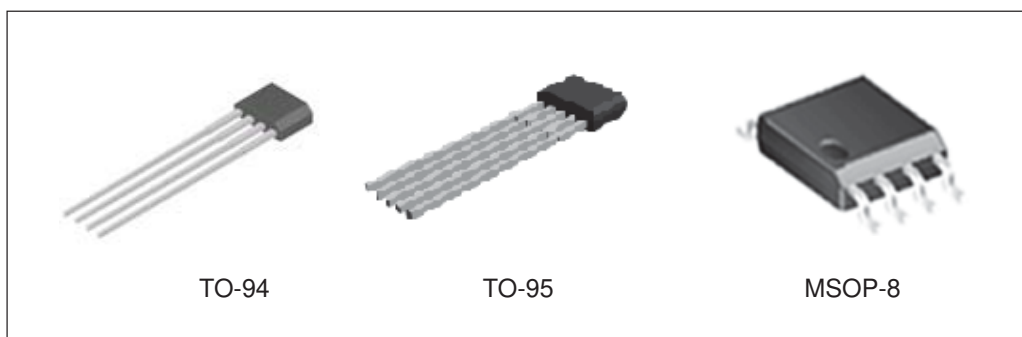

Figure 1. Package Types of AH9479/80/81

Single Phase Low Noise Smart Motor Driver

AH9479/80/81

Pin Configuration

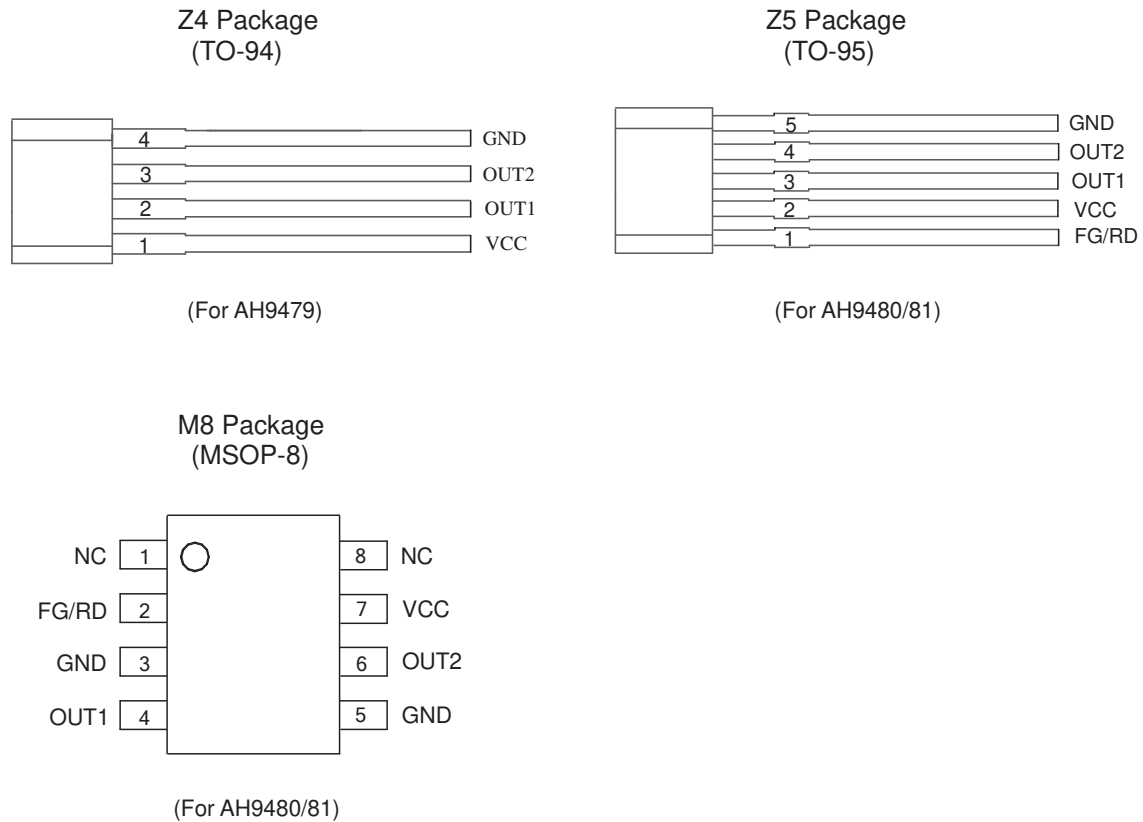
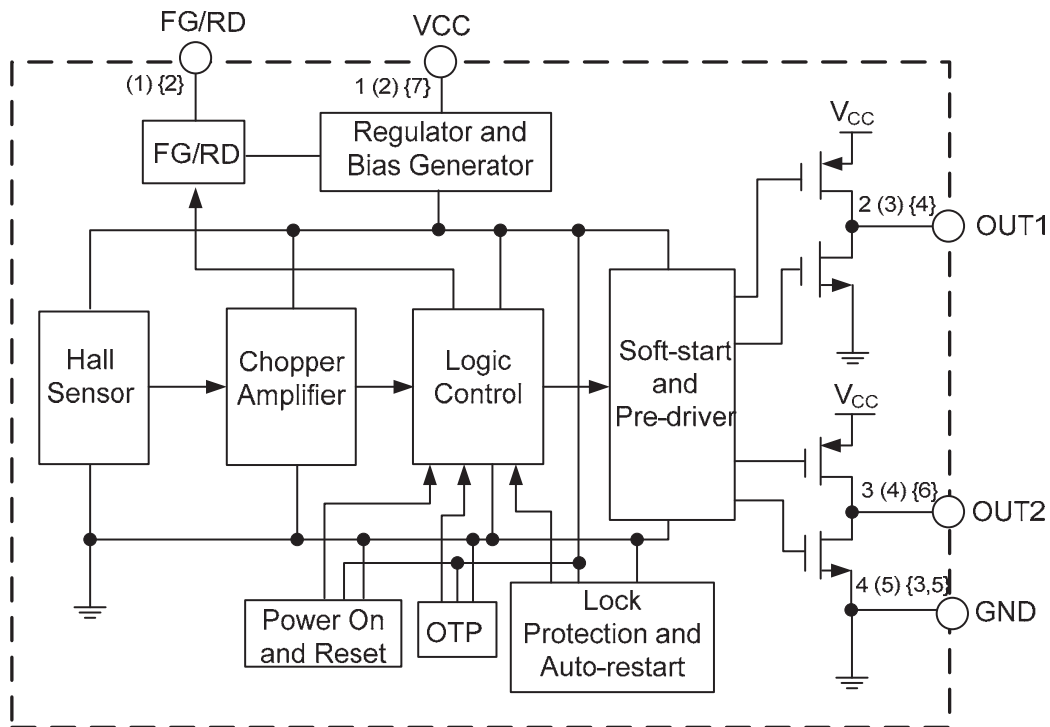

Figure 2. Pin Configuration of AH9479/80/81

Pin Description

| Pin Number | | | Pin Name | Function |
|------------|-------|--------|----------|--|
| TO-94 | TO-95 | MSOP-8 | | |
| | 1 | 2 | FG/RD | Frequency generator (rotation detection) open drain output |
| 1 | 2 | 7 | VCC | Power supply pin |
| 2 | 3 | 4 | OUT1 | Output pin 1 |
| 3 | 4 | 6 | OUT2 | Output pin 2 |
| 4 | 5 | 3, 5 | GND | Ground pin |
| | | 1, 8 | NC | No connection |

Functional Block Diagram



A (B) {C}
A for TO-94
B for TO-95
C for MSOP-8

Figure 3. Functional Block Diagram of AH9479/80/81



Single Phase Low Noise Smart Motor Driver

AH9479/80/81

Ordering Information

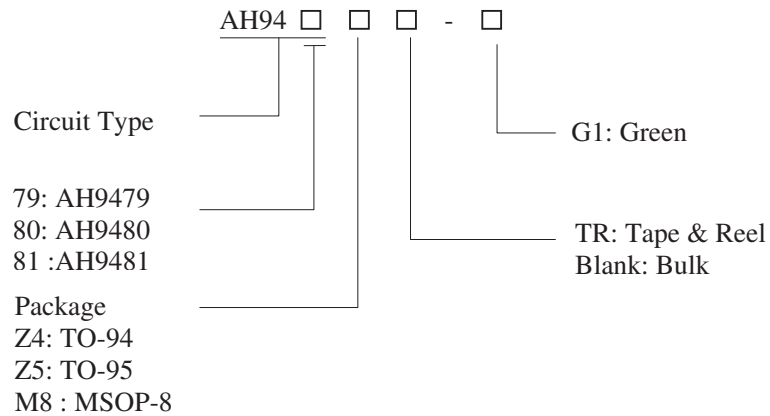

| Package | Temperature Range | Output Signal | Part Number | Marking ID | Packing Type |
|---------|-------------------|---------------|---------------|------------|--------------|
| TO-94 | -40 to 85°C | | AH9479Z4-G1 | 9479Z4-G1 | Bulk |
| TO-95 | | FG | AH9480Z5-G1 | 9480Z5-G1 | Bulk |
| | | RD | AH9481Z5-G1 | 9481Z5-G1 | Bulk |
| MSOP-8 | | FG | AH9480M8TR-G1 | 9480M8-G1 | Tape & Reel |
| | | RD | AH9481M8TR-G1 | 9481M8-G1 | Tape & Reel |

BCD Semiconductor's Pb-free products, as designated with "G1" suffix in the part number, are RoHS compliant and green.

**Single Phase Low Noise Smart Motor Driver****AH9479/80/81****Absolute Maximum Ratings (Note 1)**

| Parameter | Symbol | Value | | Unit |
|---|-----------------|------------|-----|------|
| Supply Voltage | V_{CC} | 18 | | V |
| Peak Output Current | I_{OUT_P} | 500 | | mA |
| Continuous Output Current | I_{OUT_C} | 300 | | mA |
| FG/RD Pull-up Voltage | V_{FG}/V_{RD} | 18 | | V |
| FG/RD Output Current | I_{FG}/I_{RD} | 10 | | mA |
| Power Dissipation | P_D | TO-94 | 550 | mW |
| | | TO-95 | 600 | |
| | | MSOP-8 | 585 | |
| Operating Ambient Temperature | T_A | -40 to 85 | | °C |
| Storage Temperature | T_{STG} | -55 to 150 | | °C |
| Thermal Resistance (Junction to Ambient) | θ_{JA} | TO-94 | 227 | °C/W |
| | | TO-95 | 208 | |
| | | MSOP-8 | 214 | |
| ESD (Human Body Model) | ESD | 6000 | | V |
| ESD (Machine Model) | ESD | 200 | | V |

Note 1: Stresses greater than those listed under “Absolute Maximum Ratings” may cause permanent damage to the device. These are stress ratings only, and functional operation of the device at these or any other conditions beyond those indicated under “Recommended Operating Conditions” is not implied. Exposure to “Absolute Maximum Ratings” for extended periods may affect device reliability.

Recommended Operating Conditions

| Parameter | Symbol | Min | Max | Unit |
|-------------------------------|----------|-----|-----|------|
| Supply Voltage | V_{CC} | 2.5 | 16 | V |
| Operating Ambient Temperature | T_A | -40 | 85 | °C |

**Single Phase Low Noise Smart Motor Driver****AH9479/80/81****Electrical Characteristics** $V_{CC}=12V$, $T_A=25^{\circ}C$, unless otherwise specified.

| Parameter | Symbol | Conditions | Min | Typ | Max | Unit |
|--|---------------|---|-----|------|-----|-------------|
| Supply Voltage | V_{CC} | Operating, $R_{COIL}=100\Omega$ | 2.5 | | 16 | V |
| Supply Current | I_{CC} | | | 4.3 | 12 | mA |
| ON Resistance ($R_{PMOS}+R_{NMOS}=R_S$) | $R_{DSON1,2}$ | $V_{CC}=12V, T_A=25^{\circ}C, I_{OUT}=300mA$ | | 3.3 | | Ω |
| | | $V_{CC}=12V, T_J=125^{\circ}C, I_{OUT}=300mA$ | | 3.3 | | Ω |
| FG/RD Output Low Voltage | V_{OL} | $I_{OL}=5mA$ | | 0.18 | 0.5 | V |
| FG/RD Output Leakage Current | $I_{LEAKAGE}$ | $V_{FG}(V_{RD})=5V$ | | 0.15 | 10 | μA |
| Locked Rotor Period (ON) | t_{ON} | $V_{CC}>7V$ | | 0.4 | | s |
| Locked Rotor Period (OFF) | t_{OFF} | $V_{CC}>7V$ | | 4 | | s |
| Protection Temperature | T_{OTP} | | | 175 | | $^{\circ}C$ |

Magnetic Characteristics $V_{CC}=12V$, $T_A=25^{\circ}C$, unless otherwise specified.

| Parameter | Symbol | Min | Typ | Max | Unit |
|-----------------|-----------|-----|-----|-----|-------|
| Operating Point | B_{OP} | 0 | 20 | 50 | Gauss |
| Releasing Point | B_{RP} | -50 | -20 | 0 | Gauss |
| Hysteresis | B_{HYS} | | 40 | | Gauss |

Test Circuit

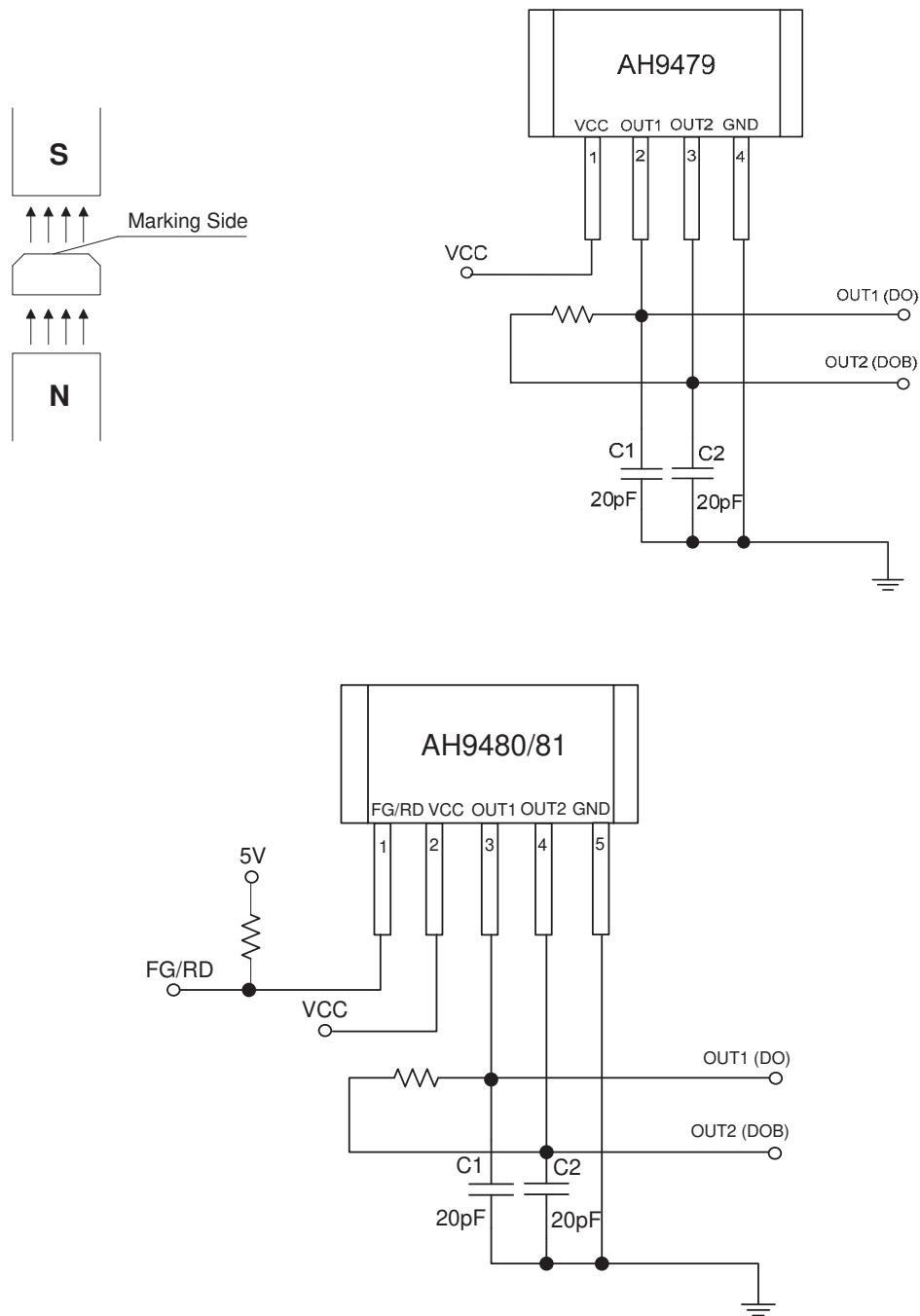

Figure 4. Basic Test Circuit of AH9479/80/81



Hysteresis Characteristics

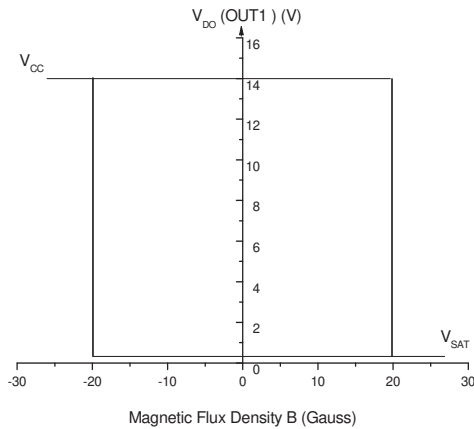

Figure 5. V_{DO} vs. Magnetic Flux Density

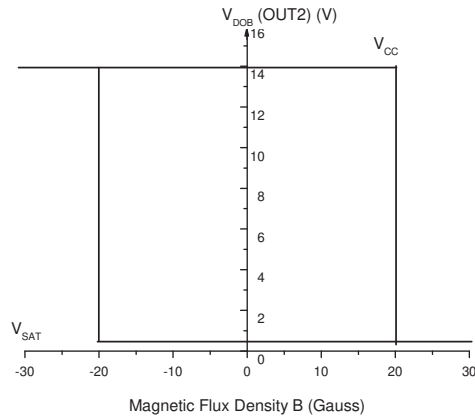

Figure 6. V_{DOB} vs. Magnetic Flux Density

Typical Performance Characteristics

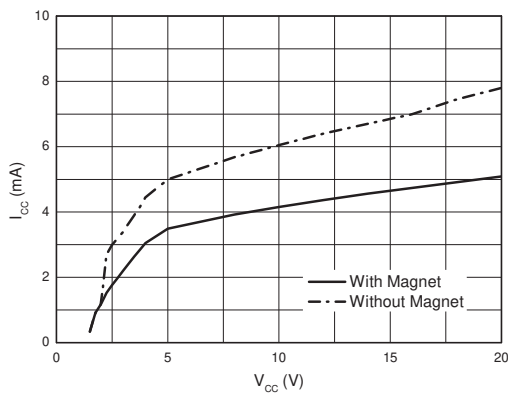

Figure 7. I_{CC} vs. V_{CC}

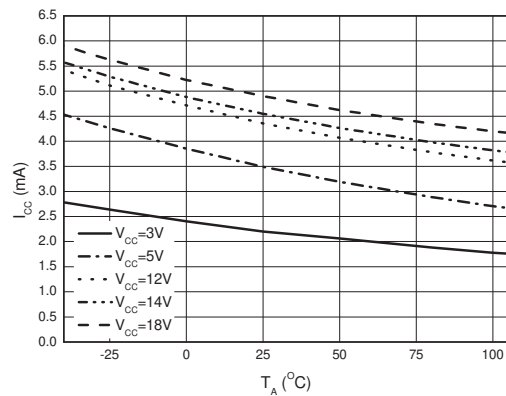

Figure 8. I_{CC} vs. T_A



Typical Performance Characteristics (Continued)

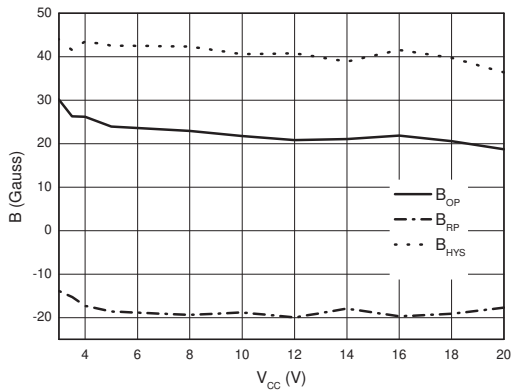

Figure 9. B_{OP}/B_{RP}/B_{HYS} vs. V_{CC}

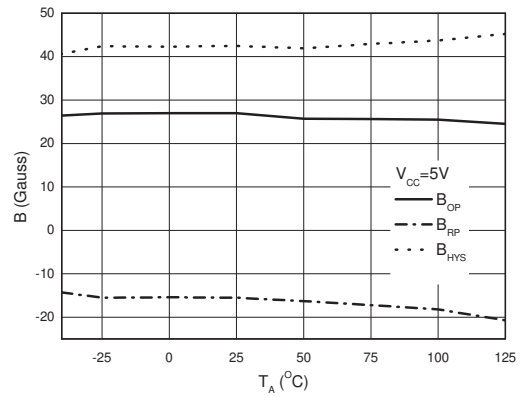

Figure 10. B_{OP}/B_{RP}/B_{HYS} vs. T_A (V_{CC}=5V)

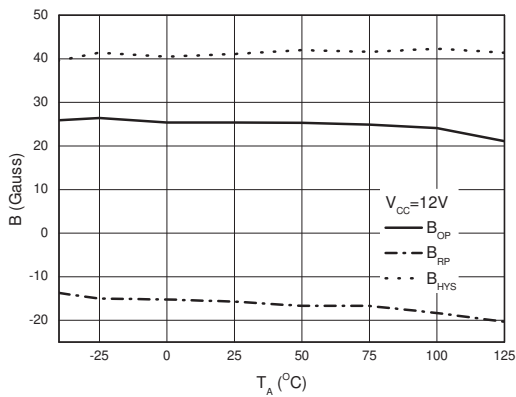

Figure 11. B_{OP}/B_{RP}/B_{HYS} vs. T_A (V_{CC}=12V)

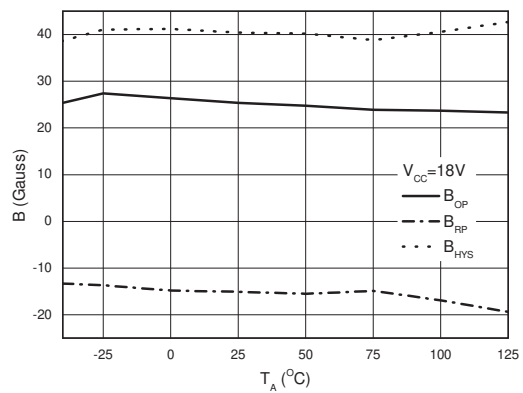

Figure 12. B_{OP}/B_{RP}/B_{HYS} vs. T_A (V_{CC}=18V)



Typical Performance Characteristics (Continued)

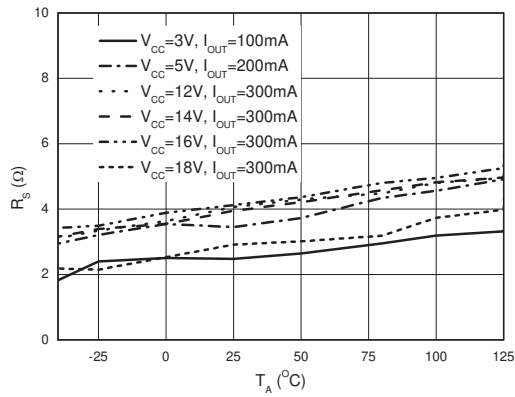

Figure 13. R_S vs. T_A

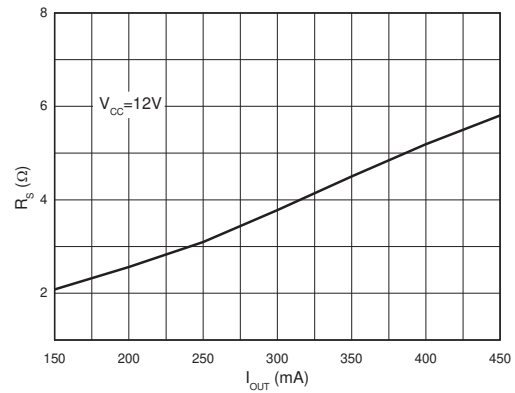

Figure 14. R_S vs. I_{OUT}

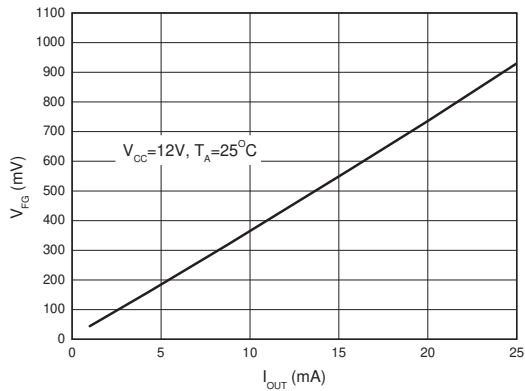

Figure 15. V_{FG} vs. I_{OUT}

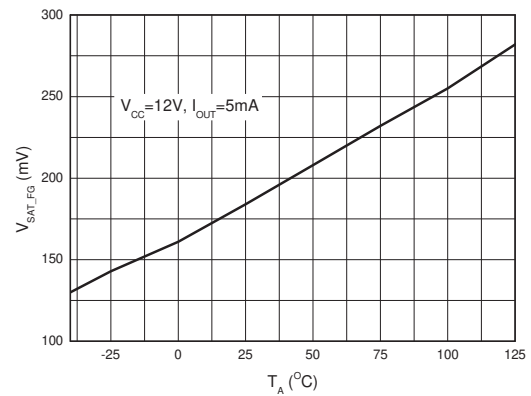

Figure 16. V_{SAT_FG} vs. T_A



Typical Performance Characteristics (Continued)

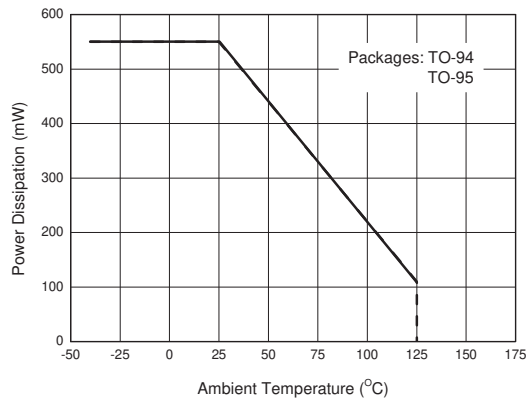

Figure 17. Power Dissipation vs. T_A

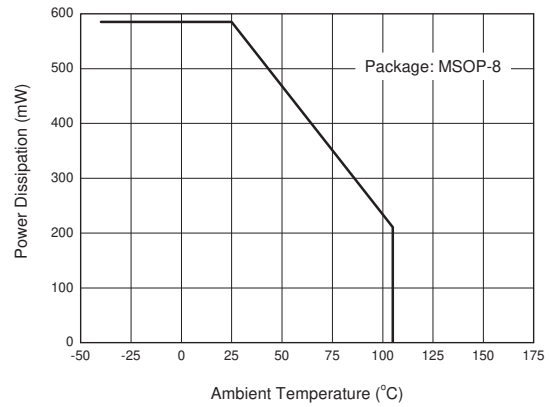
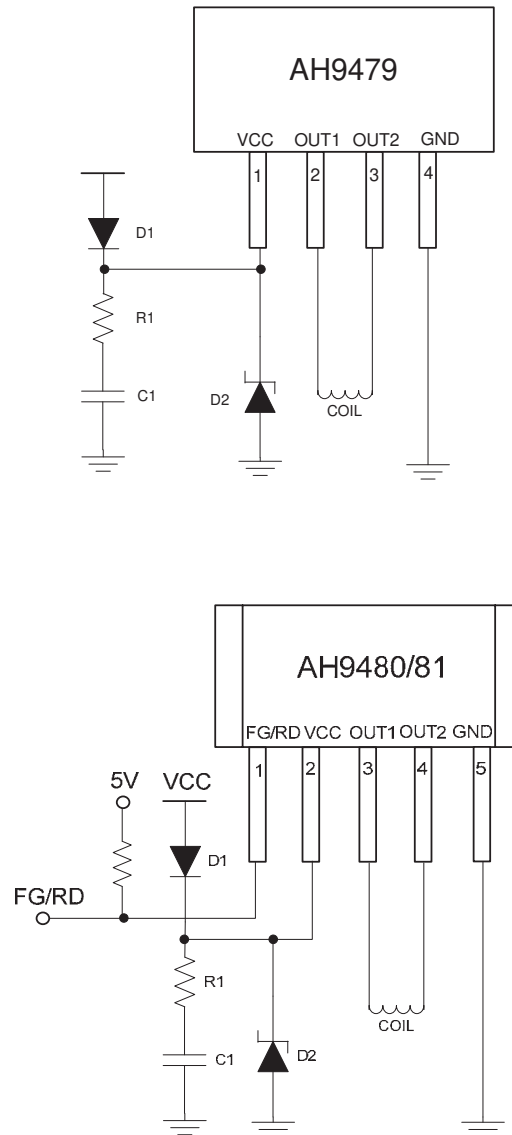

Figure 18. Power Dissipation vs. T_A

Typical Application



Note 2: C1 should be at least larger than 2.2 μ F, R1=0 to 10 Ω .

Figure 19. Typical Application of AH9479/80/81

Single Phase Low Noise Smart Motor Driver

AH9479/80/81

Mechanical Dimensions

TO-94

Unit: mm(inch)

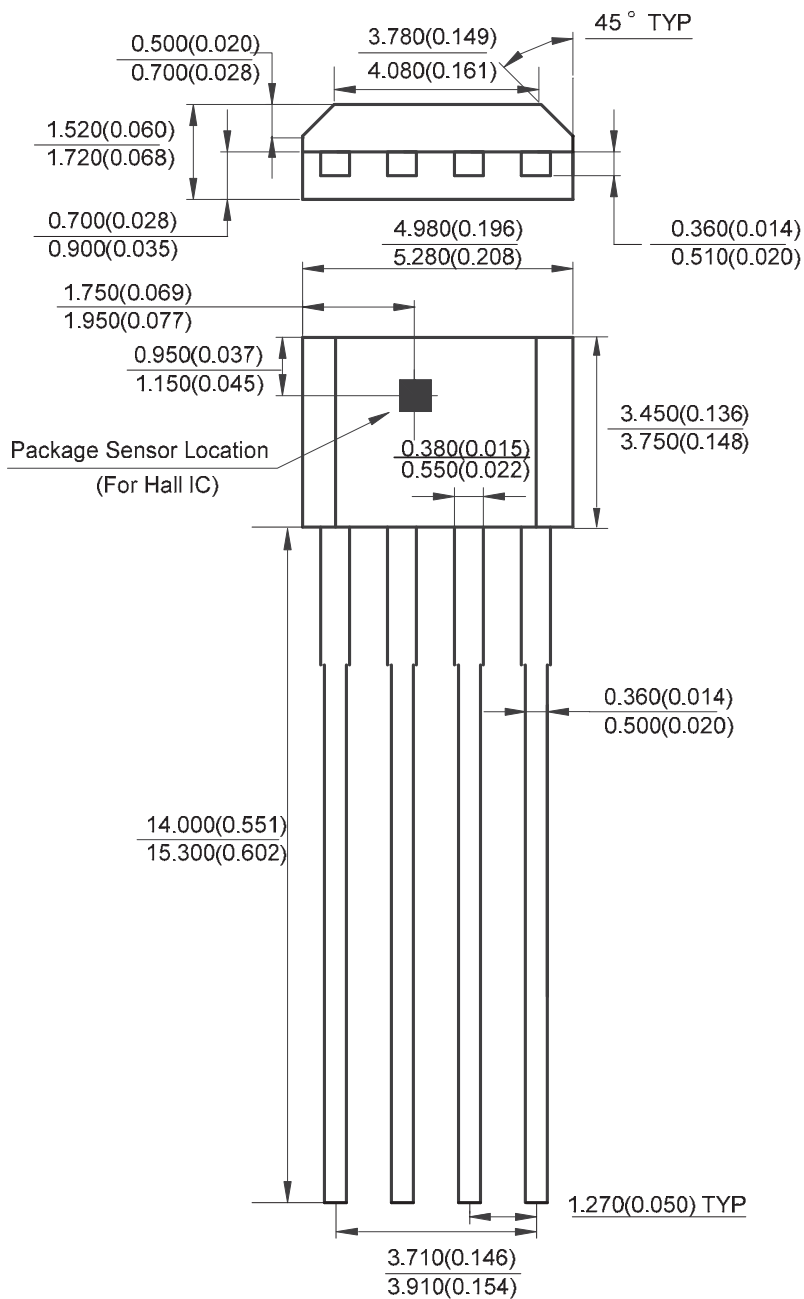



Single Phase Low Noise Smart Motor Driver

AH9479/80/81

Mechanical Dimensions (Continued)

TO-95

Unit: mm(inch)

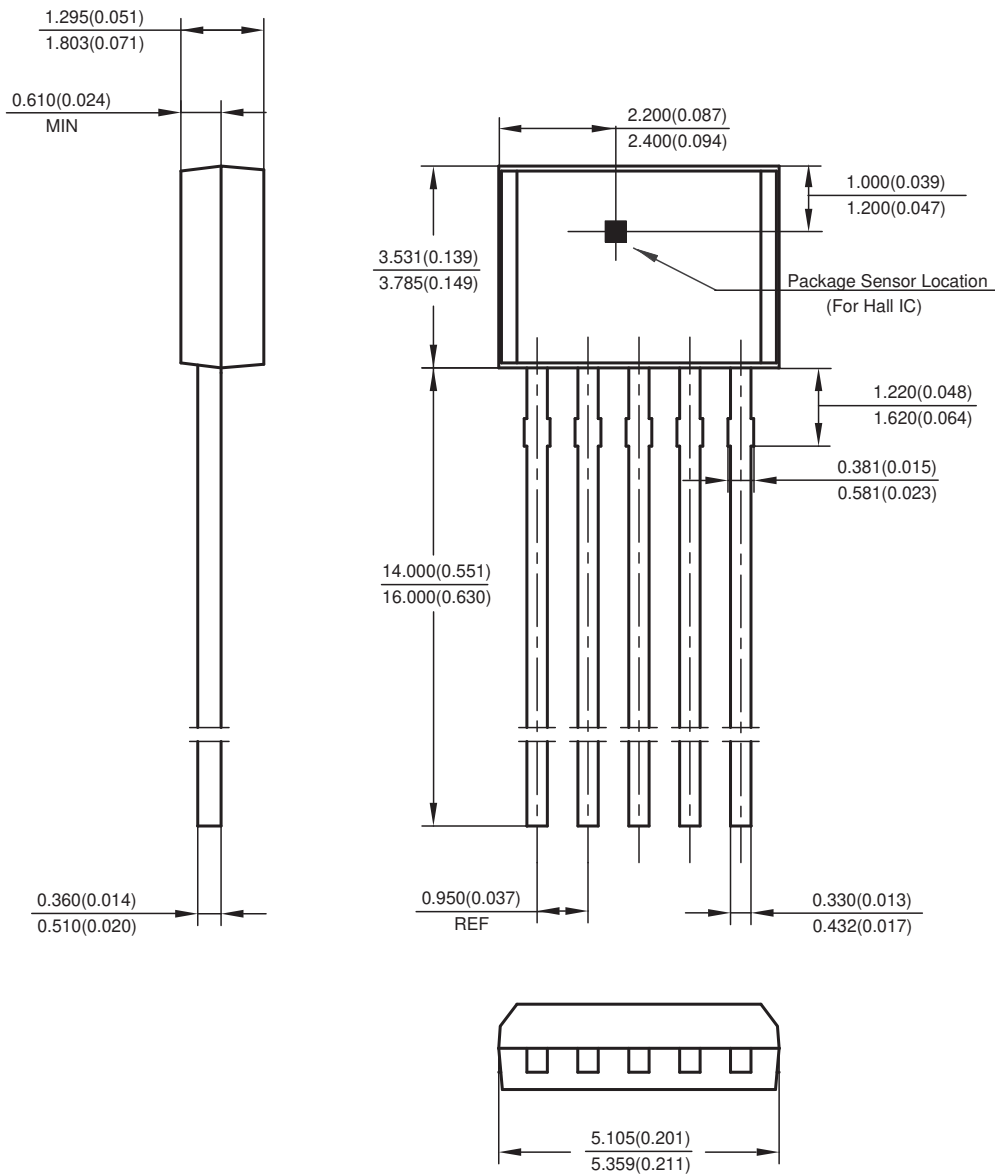

Mechanical Dimensions (Continued)

MSOP-8

Unit: mm(inch)

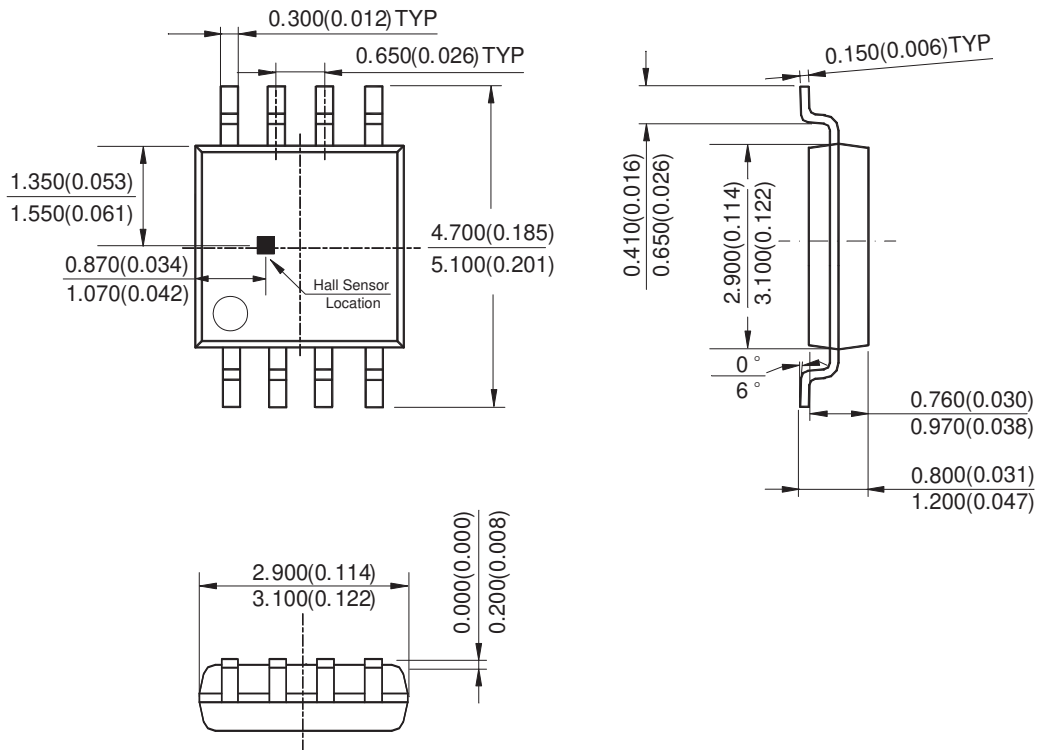

Note: Eject hole , oriented hole and mold mark is optional



BCD Semiconductor Manufacturing Limited

<http://www.bcdsemi.com>

IMPORTANT NOTICE

BCD Semiconductor Manufacturing Limited reserves the right to make changes without further notice to any products or specifications herein. BCD Semiconductor Manufacturing Limited does not assume any responsibility for use of any its products for any particular purpose, nor does BCD Semiconductor Manufacturing Limited assume any liability arising out of the application or use of any its products or circuits. BCD Semiconductor Manufacturing Limited does not convey any license under its patent rights or other rights nor the rights of others.

MAIN SITE

- Headquarters
BCD Semiconductor Manufacturing Limited
No. 1600, Zi Xing Road, Shanghai Zizhu Science-based Industrial Park, 200241, China
Tel: +86-21-24162266, Fax: +86-21-24162277

- Wafer Fab
Shanghai SIM-BCD Semiconductor Manufacturing Co., Ltd.
800 Yi Shan Road, Shanghai 200233, China
Tel: +86-21-6485 1491, Fax: +86-21-5450 0008

REGIONAL SALES OFFICE

Shenzhen Office
Shanghai SIM-BCD Semiconductor Manufacturing Co., Ltd., Shenzhen Office
Unit A Room 1203, Skyworth Bldg., Gaoxin Ave.1.S., Nanshan District, Shenzhen, China
Tel: +86-755-8826 7951
Fax: +86-755-8826 7865

Taiwan Office
BCD Semiconductor (Taiwan) Company Limited
4F, 298-1, Rui Guang Road, Nei-Hu District, Taipei, Taiwan
Tel: +886-2-2656 2808
Fax: +886-2-2656 2806

USA Office
BCD Semiconductor Corp.
30920 Huntwood Ave. Hayward, CA 94544, USA
Tel: +1-510-324-2988
Fax: +1-510-324-2788