



Chipsmall Limited consists of a professional team with an average of over 10 year of expertise in the distribution of electronic components. Based in Hongkong, we have already established firm and mutual-benefit business relationships with customers from,Europe,America and south Asia,supplying obsolete and hard-to-find components to meet their specific needs.

With the principle of "Quality Parts,Customers Priority,Honest Operation,and Considerate Service",our business mainly focus on the distribution of electronic components. Line cards we deal with include Microchip,ALPS,ROHM,Xilinx,Pulse,ON,Everlight and Freescale. Main products comprise IC,Modules,Potentiometer,IC Socket,Relay,Connector.Our parts cover such applications as commercial,industrial, and automotives areas.

We are looking forward to setting up business relationship with you and hope to provide you with the best service and solution. Let us make a better world for our industry!



Contact us

Tel: +86-755-8981 8866 Fax: +86-755-8427 6832

Email & Skype: info@chipsmall.com Web: www.chipsmall.com

Address: A1208, Overseas Decoration Building, #122 Zhenhua RD., Futian, Shenzhen, China



REVISIONS					
REV	ECO	DESCRIPTION	DATE	BY	APPR
01		PRELIMINARY DRAWING	08NOV16	SULLENTOMMY	
02		DESIGN CHANGE	16MAY17	SULLENTOMMY	
03		CHANGE P/N TO AHDC04-24-PM	01JUN17	SULLENTOMMY	
04		REMOVE CORD	15AUG17	SULLENTOMMY	

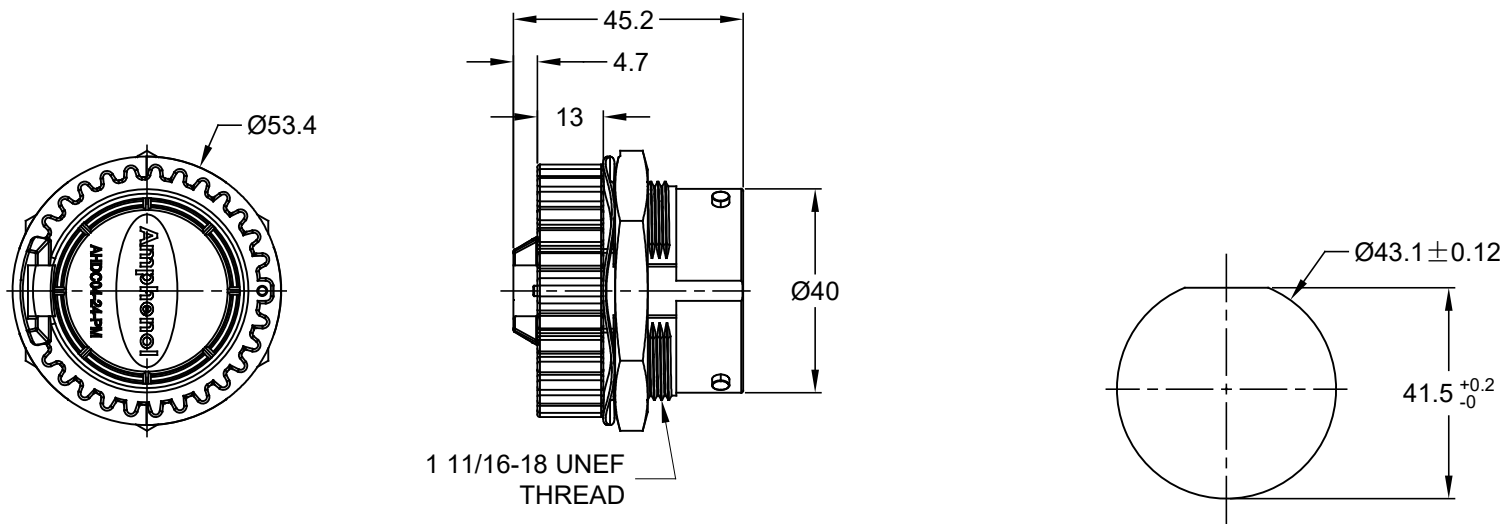

RECOMMENDED PANEL MOUNTING HOLE
RECOMMENDED PANEL THICKNESS: 1.6 TO 4.7MM

NOTES: UNLESS OTHERWISE SPECIFIED

- MATERIAL:
SHELL: THERMOPLASTIC
NUT: THERMOPLASTIC
SEAL: SILICONE RUBBER
LOCK WASHER: STEEL
- COLORS: BLACK
- RoHS COMPLIANT
- COMPATIBLE WITH ALL SIZE 24 AHDP SERIES PLUG.
- ALL DIMENSIONS ARE FOR REFERENCE USE ONLY.

AHDC04-24-PM				
PART NUMBER		DESCRIPTION		ITEM
QUANTITY	MATERIALS LIST			
UNLESS OTHERWISE SPECIFIED 1) All dimensions are in metric(mm). 2) Tolerances are as follows: 1 PL DEC ±0.30 2 PL DEC ±0.15 3 PL DEC ±0.08 Fractions ±1/64 Angles ±1° 3) Note reference =		SIGNATURES DATE		<h1>Amphenol</h1> <p>Sine Systems - www.amphenol-sine.com 44724 Morley Drive Clinton Township, MI 48036</p>
MATERIAL SPECIFICATIONS:		DRAWN: SULLEN.ZHANG 01JUN17		
		CHECKED: ORION.LI 01JUN17		
		ENGINEER:		
PROCESS SPECIFICATIONS:		APPROVAL: TOMMY.XIE 01JUN17		
		CUSTOMER:		
NEXT ASSY:		THIS DRAWING IS SUPPLIED FOR INFORMATION ONLY. DESIGN FEATURES, SPECIFICATIONS AND PERFORMANCE DATA SHOWN HEREON ARE THE PROPERTY OF THE AMPHENOL CORPORATION. NO RIGHTS OF REPRODUCTION ARE IMPLIED. ALL DIMENSIONS ARE SUBJECT TO NORMAL MANUFACTURING VARIATIONS.		SIZE: A TYPE: C- SCALE: NONE
		DWG NO: AHDC04-24-PM		REVISION: 04
		SHEET 1 OF 1		