



Chipsmall Limited consists of a professional team with an average of over 10 year of expertise in the distribution of electronic components. Based in Hongkong, we have already established firm and mutual-benefit business relationships with customers from,Europe,America and south Asia,supplying obsolete and hard-to-find components to meet their specific needs.

With the principle of "Quality Parts,Customers Priority,Honest Operation,and Considerate Service",our business mainly focus on the distribution of electronic components. Line cards we deal with include Microchip,ALPS,ROHM,Xilinx,Pulse,ON,Everlight and Freescale. Main products comprise IC,Modules,Potentiometer,IC Socket,Relay,Connector.Our parts cover such applications as commercial,industrial, and automotives areas.

We are looking forward to setting up business relationship with you and hope to provide you with the best service and solution. Let us make a better world for our industry!



## Contact us

Tel: +86-755-8981 8866 Fax: +86-755-8427 6832

Email & Skype: info@chipsmall.com Web: www.chipsmall.com

Address: A1208, Overseas Decoration Building, #122 Zhenhua RD., Futian, Shenzhen, China



# SMT Air Coil Inductor

AIAC-1812

**RoHS**  
Compliant

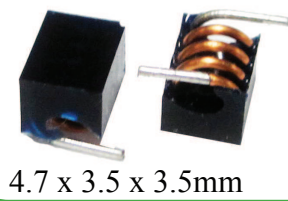

4.7 x 3.5 x 3.5mm

## FEATURES:

- High current design
- Wide Range Frequency Response
- Excellent Q & SRF
- Standard flat cap top suitable for automatic placement.

## APPLICATIONS:

- Widely used in Cordless Phones, High Frequency Communication Equipments, Intercom, CATV,RFID
- Suitable for metal sensors and proximity sensors
- Noise suppression for RF power supply/bias
- I/O filtering, frequency selection for audio devices such as Loudspeakers,Hifi
- Impedance Matching for transceivers
- Improves switch isolation for RF circuit

## STANDARD SPECIFICATIONS:

PARAMETERS	
ABRACON P/N:	AIAC-1812
Operating temperature:	-40 °C ~ +125 °C
Storage temperature:	-25°C to + 60°C

Part Number	Inductance	Tolerance	DCR (Max)	Q(Min)	SRF(Min)	Rated Current (Max)	Inductance Code
Units	nH	%	mΩ		G Hz	A	
Symbol	L	J, K	DCR			IDC	
AIAC-1812-22N	22	K	4.8	100.0	3.20	3.2	22NK
AIAC-1812-27N	27	K	4.6	100.0	2.70	3.5	27NK
AIAC-1812-33N	33	K	5.9	100.0	2.50	3.0	33NK
AIAC-1812-39N	39	J	5.6	100.0	2.10	2.8	39NJ
AIAC-1812-47N	47	J	6.9	100.0	2.10	2.8	47NJ
AIAC-1812-56N	56	J	6.4	100.0	1.50	2.9	56NJ
AIAC-1812-68N	68	J	8.1	100.0	1.50	2.9	68NJ
AIAC-1812-82N	82	J	8.9	100.0	1.30	2.6	82NJ
AIAC-1812-R10	100	J	10.0	100.0	1.20	2.5	R10J
AIAC-1812-R12	120	J	11.1	100.0	1.10	2.2	R12J

## Test Conditions and equipments

Test frequency: 150MHz

Equipment: HP4191A

## PART IDENTIFICATION:

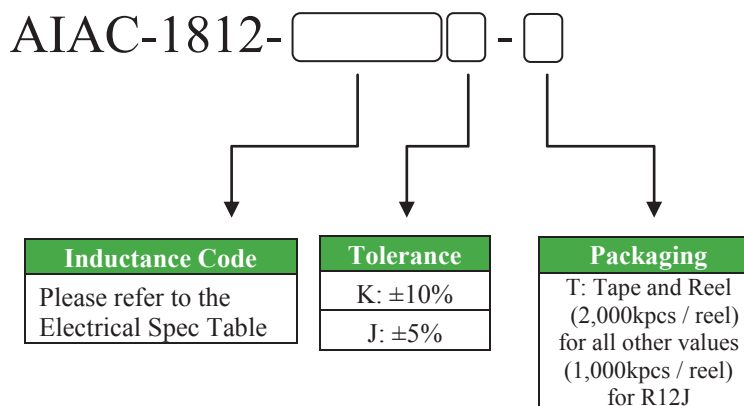

# SMT Air Coil Inductor

AIAC-1812

RoHS  
Compliant

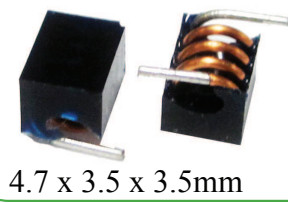

## OUTLINE DRAWING:

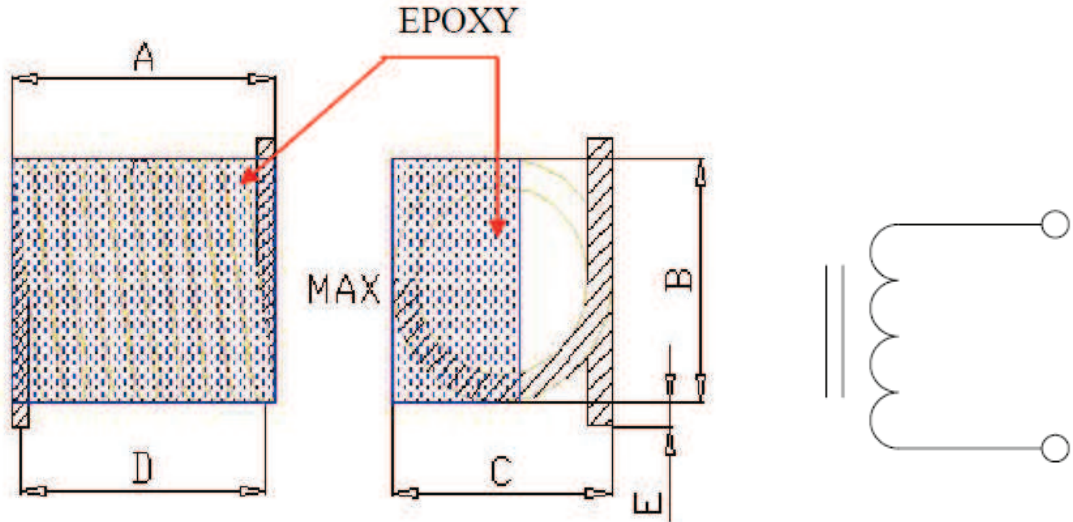

Inductance code	A	B	C	D	E
All others	4.7±0.3	3.5±0.2	3.5±0.2	4.3±0.4	1.0±0.3
R12J only	4.9±0.3	3.8±0.2	3.8±0.2		

### Recommended Landing Pattern

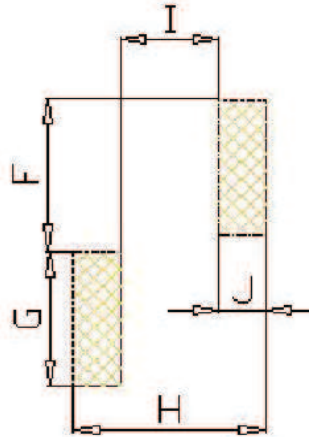

F	G	H	I	J
2.7	5.2	5.8	2.9	1.5

Dimension: inch (mm)

# SMT Air Coil Inductor

AIAC-1812

**RoHS**  
Compliant

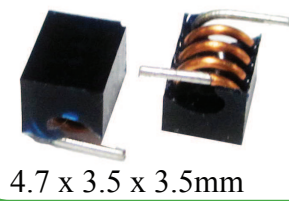

4.7 x 3.5 x 3.5mm

## REFLOW PROFILE:

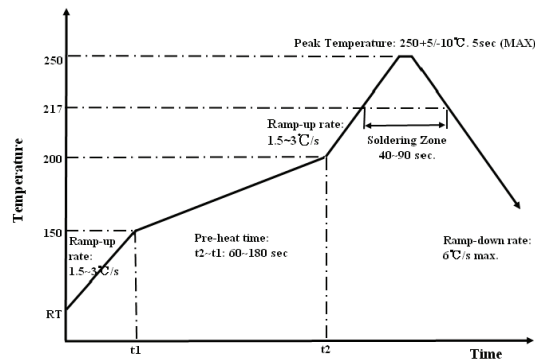

## TAPE & REEL:

**Packing (For R12J only)**  
**T: 1,000pcs / reel**

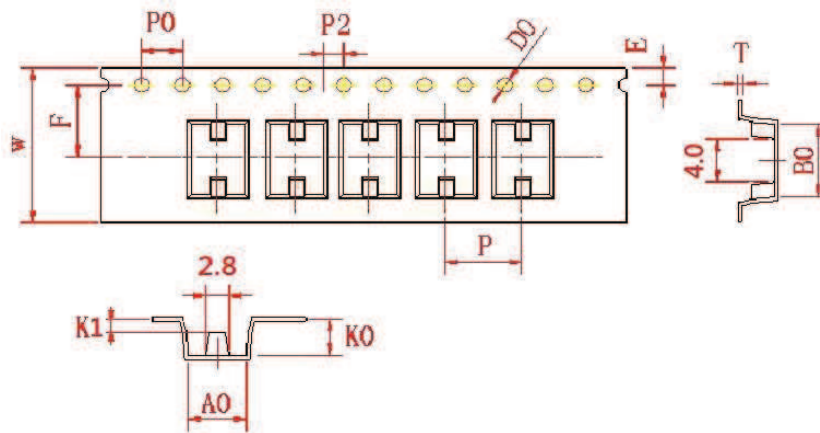

W	A0	B0	K0	K1	P	F	E	D0	P0	P2	T
16±0.3	5.7±0.1	7.1±0.1	4.2±0.1	2.0±0.1	8.0±0.1	7.5±0.1	1.75±0.1	1.5+0.1/-0	4.0±0.1	2.0±0.1	0.4±0.05

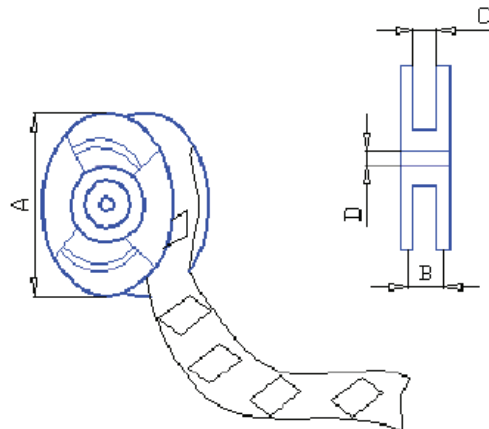

A	330
B	22
C	16
D	13.5

**Dimension: mm**

# SMT Air Coil Inductor

AIAC-1812

RoHS  
Compliant

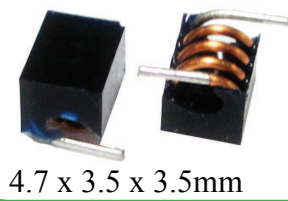

4.7 x 3.5 x 3.5mm

## TAPE & REEL:

Packing (For all part numbers other than R12J)  
T: 2,000pcs / reel

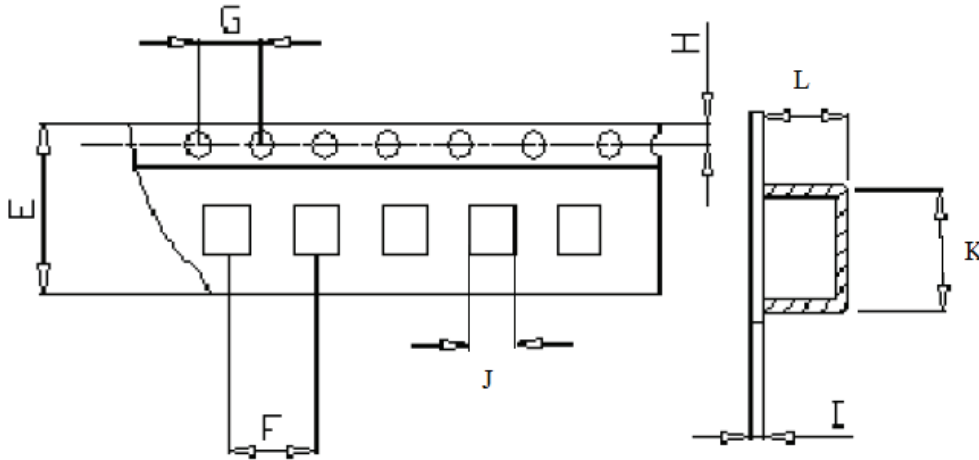

E	F	G	H	I	J max	K max	L max
16	8	4	1.75	0.4	5.70±0.1	7.10±0.1	4.20±0.1

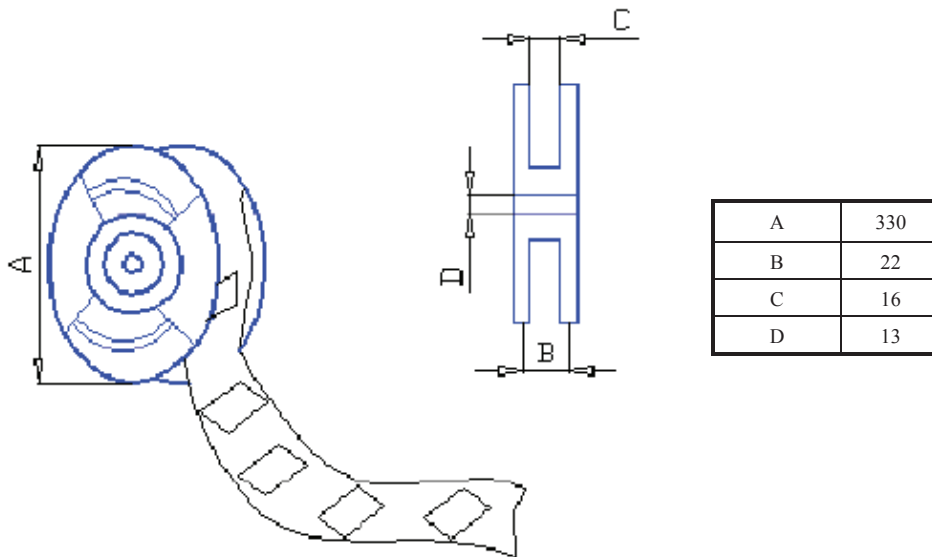

A	330
B	22
C	16
D	13

Dimension: mm

**ATTENTION:** Abracon Corporation's products are COTS – Commercial-Off-The-Shelf products; suitable for Commercial, Industrial and, where designated, Automotive Applications. Abracon's products are not specifically designed for Military, Aviation, Aerospace, Life-dependant Medical applications or any application requiring high reliability where component failure could result in loss of life and/or property. For applications requiring high reliability and/or presenting an extreme operating environment, written consent and authorization from Abracon Corporation is required. Please contact Abracon Corporation for more information.