



Chipsmall Limited consists of a professional team with an average of over 10 year of expertise in the distribution of electronic components. Based in Hongkong, we have already established firm and mutual-benefit business relationships with customers from,Europe,America and south Asia,supplying obsolete and hard-to-find components to meet their specific needs.

With the principle of "Quality Parts,Customers Priority,Honest Operation,and Considerate Service",our business mainly focus on the distribution of electronic components. Line cards we deal with include Microchip,ALPS,ROHM,Xilinx,Pulse,ON,Everlight and Freescale. Main products comprise IC,Modules,Potentiometer,IC Socket,Relay,Connector.Our parts cover such applications as commercial,industrial, and automotives areas.

We are looking forward to setting up business relationship with you and hope to provide you with the best service and solution. Let us make a better world for our industry!



Contact us

Tel: +86-755-8981 8866 Fax: +86-755-8427 6832

Email & Skype: info@chipsmall.com Web: www.chipsmall.com

Address: A1208, Overseas Decoration Building, #122 Zhenhua RD., Futian, Shenzhen, China



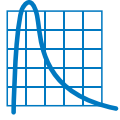

AIT

Active In-car Temperature Sensor



An integrated, low-noise fan draws a greater volume of cabin air across the temperature sensor, providing a faster response as compared to traditional passive sensors. This can result in a more accurate climate control, leading to better cabin comfort. This sensor can also help improve the efficiency of the temperature control system by reducing the on / off cycles of the heating and cooling system.

Applications

- For in cabin vehicle temperature measurement for vehicles that have an automated temperature control system

Features

- Existing field proven design
- Fast Response
- Accuracy maximizes driver/passenger comfort
- Ultra-low noise, high air flow optimised system design
- Coreless Type Motor
- Small size & flexible packaging facilitates installation & service
- Low current consumption
- Long-term stability – even in extreme humidity environments
- Alternate RvT curves available
- Available with/without humidity sensor
- Electronics integrated into one assembly with the temperature sensor.
- Different geometries to meet package requirements

Specifications

R @ 25°C

30.0 kΩ ±1.2%

B (0/50)

3887K ±1%

Operating Temperature Range

-40°C to 85°C

Storage Temperature Range

-40°C to 85°C

Response Time

< 10 seconds (25°C to > 85°C in OIL)

Housing Material

PP-(GF+TD)15

NTC Part Number

TC330S39FB

Weight

29.5 grams/piece

Air Flow Volume

Minimum 1.2 m/s (at 23 ±5°C, 13.5 ±0.1V), inlet

Operating Current

70.0mA Maximum (at 14.0 ±0.1V)

Rated Voltage

12.0V

Minimum Starting Voltage

9.0V MAX

Noise

38.0dB MAX (at 12.0±0.1V)

Connector

YAZAKI 7282-8663

Mating Connector

KET MG651439

Resistance and Temperature Accuracy

Temp. (°C)	Tolerance (%)	R (KOhms)	Tolerance (%)
+60	-0.73/+0.71	7.463	±2.6
+50	-0.59/+0.58	10.810	±2.2
+35	±0.39	19.590	±1.6
+25	±0.27	30.000	±1.2
+15	-0.36/+0.35	47.130	±1.7
0	-0.47/+0.46	97.710	±2.4
-15	-0.58/+0.57	216.100	-3.1/+3.2
-30	-0.69/+0.67	509.600	-4.0/+4.1

Drawing

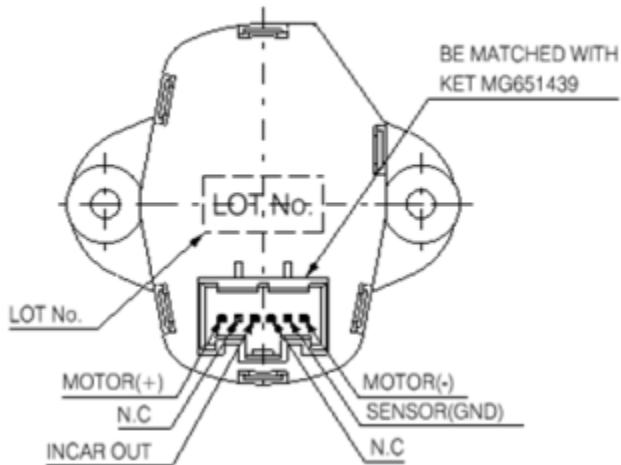
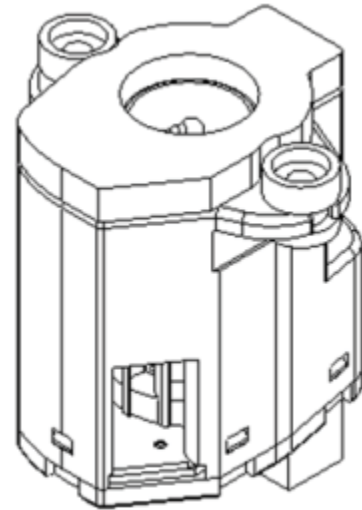
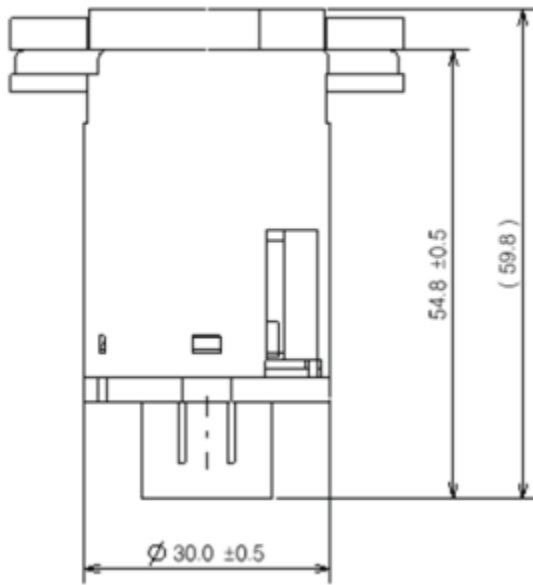
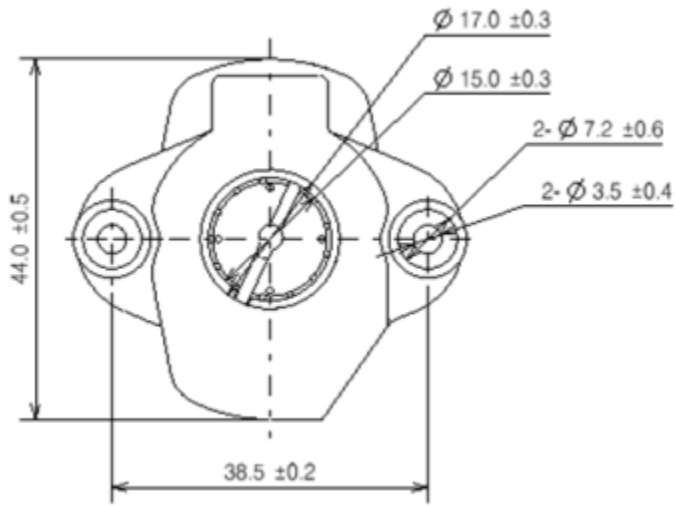

Amphenol
Advanced Sensors

www.amphenol-sensors.com

© 2014 Amphenol Corporation. All Rights Reserved. Specifications are subject to change without notice.
Other company names and product names used in this document are the registered trademarks or
trademarks of their respective owners.

AAS-920-527A-03/2014