



Chipsmall Limited consists of a professional team with an average of over 10 year of expertise in the distribution of electronic components. Based in Hongkong, we have already established firm and mutual-benefit business relationships with customers from,Europe,America and south Asia,supplying obsolete and hard-to-find components to meet their specific needs.

With the principle of “Quality Parts,Customers Priority,Honest Operation,and Considerate Service”,our business mainly focus on the distribution of electronic components. Line cards we deal with include Microchip,ALPS,ROHM,Xilinx,Pulse,ON,Everlight and Freescale. Main products comprise IC,Modules,Potentiometer,IC Socket,Relay,Connector.Our parts cover such applications as commercial,industrial, and automotives areas.

We are looking forward to setting up business relationship with you and hope to provide you with the best service and solution. Let us make a better world for our industry!



Contact us

Tel: +86-755-8981 8866 Fax: +86-755-8427 6832

Email & Skype: info@chipsmall.com Web: www.chipsmall.com

Address: A1208, Overseas Decoration Building, #122 Zhenhua RD., Futian, Shenzhen, China





AK09912

3-axis Electronic Compass

1. Features

- A 3-axis electronic compass IC with high sensitive Hall sensor technology.
- Best adapted to pedestrian city navigation use for cell phone and other portable appliance.
- Functions:
 - 3-axis magnetometer device suitable for compass application
 - Built-in A to D Converter for magnetometer data out
 - 16-bit data out for each 3-axis magnetic component
 - Sensitivity: 0.15 μ T/LSB (typ.)
 - Serial interface
 - I²C bus interface
Standard, Fast and High-speed modes (up to 2.5 MHz) compliant with Philips I2C specification Ver.2.1
 - 4-wire SPI
 - Operation mode
 - Power-down, Single measurement, Continuous measurement, External trigger measurement, Self-test and Fuse ROM access
 - DRDY (Data Ready) function for measurement data ready
 - Magnetic sensor overflow monitor function
 - Built-in oscillator for internal clock source
 - Power on Reset circuit
 - Self test function with internal magnetic source
 - Built-in Noise Suppression Filter (NSF)
 - Built-in temperature sensor
- Operating temperatures:
 - -30°C to +85°C
- Operating supply voltage:
 - Analog power supply +1.7V to +3.6V
 - Digital Interface supply +1.65V to analog power supply voltage
- Current consumption:
 - Power-down: 3 μ A (typ.)
 - Measurement:
 - Average current consumption at 100 Hz repetition rate: 1 mA (typ.)
- Package:
 - AK09912C 14-pin WL-CSP (BGA): 1.6 mm \times 1.6 mm \times 0.5 mm (typ.)

2. Overview

AK09912 is 3-axis electronic compass IC with high sensitive Hall sensor technology.

Small package of AK09912 incorporates magnetic sensors for detecting terrestrial magnetism in the X-axis, Y-axis, and Z-axis, a sensor driving circuit, signal amplifier chain, and an arithmetic circuit for processing the signal from each sensor. Self test function is also incorporated. From its compact foot print and thin package feature, it is suitable for map heading up purpose in GPS-equipped cell phone to realize pedestrian navigation function.

AK09912 has the following features:

- (1) Silicon monolithic Hall-effect magnetic sensor with magnetic concentrator realizes 3-axis magnetometer on a silicon chip. Analog circuit, digital logic, power block and interface block are also integrated on a chip.
- (2) Wide dynamic measurement range and high resolution with lower current consumption.
 - Output data resolution: 16-bit (0.15 μ T/LSB)
 - Measurement range: $\pm 4900 \mu$ T
 - Average current at 100 Hz repetition rate: 1 mA (typ.)
- (3) Digital serial interface
 - I²C bus interface to control AK09912 functions and to read out the measured data by external CPU. A dedicated power supply for I²C bus interface can work in low-voltage apply as low as 1.65V.
 - 4-wire SPI is also supported. A dedicated power supply for SPI can work in low-voltage apply as low as 1.65V.
- (4) DRDY pin and register inform to system that measurement is end and set of data in registers are ready to be read.
- (5) Device is worked by on-chip oscillator so no external clock source is necessary.
- (6) Self test function with internal magnetic source to confirm magnetic sensor operation on end products.
- (7) Built-in NSF (Noise Suppression Filter) keeps magnetic sensor output stable.
- (8) Built-in temperature sensor to monitor the temperature while operation.

3. Table of Contents

1. Features	1
2. Overview.....	2
3. Table of Contents.....	3
4. Circuit Configuration.....	5
4.1. Block Diagram	5
4.2. Block Function	5
4.3. Pin Function	6
5. Overall Characteristics	7
5.1. Absolute Maximum Ratings	7
5.2. Recommended Operating Conditions	7
5.3. Electrical Characteristics	7
5.3.1. DC Characteristics	7
5.3.2. AC Characteristics	8
5.3.3. Analog Circuit Characteristics	9
5.3.4. 4-wire SPI.....	10
5.3.5. I ² C Bus Interface	11
6. Function Explanation.....	14
6.1. Power States.....	14
6.2. Reset Functions.....	14
6.3. Operation Mode	15
6.4. Description of Each Operation Mode	16
6.4.1. Power-down Mode	16
6.4.2. Single Measurement Mode.....	16
6.4.3. Continuous Measurement Mode 1, 2, 3 and 4	17
6.4.4. External Trigger Measurement Mode	20
6.4.5. Self-test Mode	20
6.4.6. Fuse ROM Access Mode	20
6.5. Temperature Sensor	21
6.6. Noise Suppression Filter (NSF).....	21
7. Serial Interface	22
7.1. 4-wire SPI	22
7.1.1. Writing Data.....	22
7.1.2. Reading Data	23
7.2. I ² C Bus Interface.....	24
7.2.1. Data Transfer	24
7.2.2. WRITE Instruction	26
7.2.3. READ Instruction.....	27
7.3. High-speed Mode (Hs-mode)	28
8. Registers	29
8.1. Description of Registers	29
8.2. Register Map	30
8.3. Detailed of Description of Register.....	31
8.3.1. WIA: Who I Am.....	31
8.3.2. RSV: Reserved	31
8.3.3. ST1: Status 1	31
8.3.4. HXL to HZH: Measurement Data	32
8.3.5. TMPS: Temperature Data	33
8.3.6. ST2: Status 2.....	33
8.3.7. CNTL1: Control 1	34
8.3.8. CNTL2: Control 2	34
8.3.9. CNTL3: Control 3	35
8.3.10. TS1, TS2, TS3: Test.....	35
8.3.11. I2CDIS: I ² C Disable.....	36
8.3.12. TS4: Test 4	36
8.3.13. ASAX, ASAY, ASAZ: Sensitivity Adjustment Values	36
9. Example of Recommended External Connection	37

9.1. I ² C Bus Interface.....	37
9.2. 4-wire SPI	38
10. Package.....	39
10.1. Marking	39
10.2. Pin Assignment.....	39
10.3. Outline Dimensions	40
10.4. Recommended Foot Print Pattern.....	40
11. Relationship between the Magnetic Field and Output Code.....	41

4. Circuit Configuration

4.1. Block Diagram

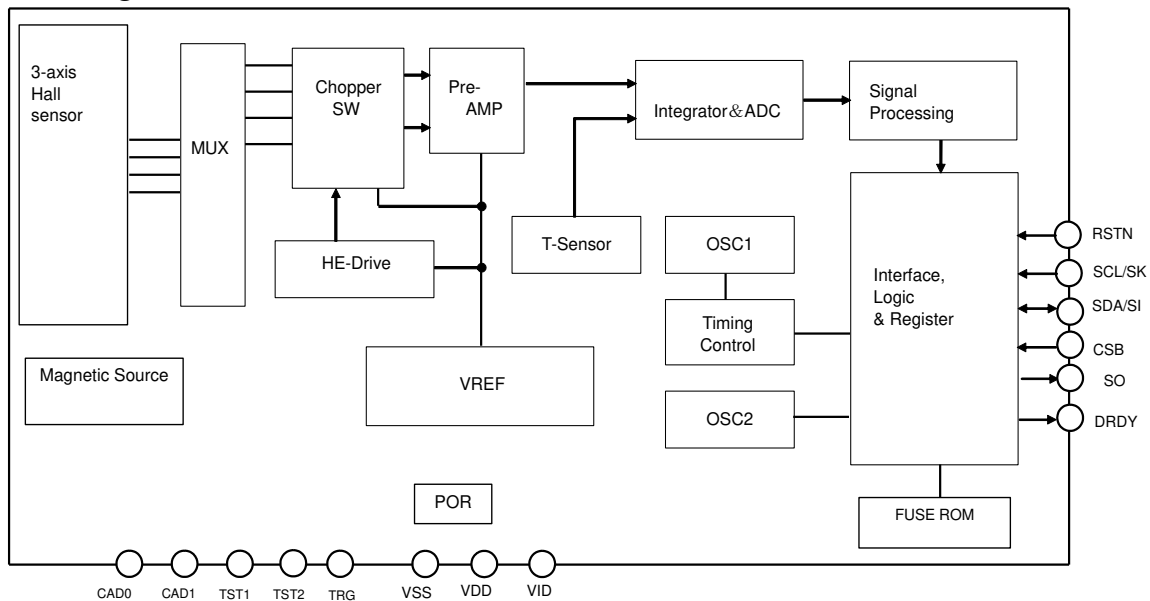

4.2. Block Function

Block	Function
3-axis Hall sensor	Monolithic Hall elements.
MUX	Multiplexer for selecting Hall elements.
Chopper SW	Performs chopping.
HE-Drive	Magnetic sensor drive circuit for constant-current driving of sensor.
Pre-AMP	Fixed-gain differential amplifier used to amplify the magnetic sensor signal.
T-Sensor	Temperature sensor. Generate a voltage in proportion to temperature.
Integrator & ADC	Integrates and amplifies pre-AMP output or T-sensor output and performs analog-to-digital conversion.
OSC1	Generates an operating clock for sensor measurement.
OSC2	Generates an operating periodic clock for sequencer.
POR	Power On Reset circuit. Generates reset signal on rising edge of VDD.
VREF	Generates reference voltage and current.
Interface Logic & Register	Exchanges data with an external CPU. DRDY pin indicates sensor measurement has ended and data is ready to be read. I2C bus interface using two pins, namely, SCL and SDA. Standard, Fast and High-speed modes are supported. The low-voltage specification can be supported by applying 1.65V to the VID pin. 4-wire SPI is also supported by SK, SI, SO and CSB pins. 4-wire SPI works in VID pin voltage down to 1.65 V, too.
Signal Processing	Noise suppression function by the filtering process. Filtering process can be enabled or disabled.
Timing Control	Generates a timing signal required for internal operation from a clock generated by the OSC1.
Magnetic Source	Generates magnetic field for self test of magnetic sensor.
FUSE ROM	Fuse ROM for adjustment.

4.3. Pin Function

Pin No.	Pin name	I/O	Power supply	Type	Function
A1	DRDY	O	VID	CMOS	Data Ready output pin. “H” active. Informs measurement ended and data is ready to be read.
A2	CSB	I	VID	CMOS	Chip select pin for 4-wire SPI. “L” active. Connect to VID when selecting I2C bus interface.
A3	SCL	I	VID	CMOS	When the I2C bus interface is selected (CSB pin is connected to VID). SCL: Control clock input pin Input: Schmitt trigger
	SK				When the 4-wire SPI is selected. SK: Serial clock input pin.
A4	SDA	I/O	VID	CMOS	When the I2C bus interface is selected (CSB pin is connected to VID). SDA: Control data input/output pin Input: Schmitt trigger, Output: Open drain
	SI	I			When the 4-wire SPI is selected. SI: Serial data input pin
B1	VDD	-	-	Power	Positive power supply pin.
B3	TST2	O	VID	CMOS	Test pin. Connect to VSS or keep this pin non-connected.
B4	SO	O	VID	CMOS	When the I2C bus interface is selected (CSB pin is connected to VID) Hi-Z output. Keep this pin electrically non-connected.
					When the 4-wire SPI is selected. Serial data output pin
C1	VSS	-	-	Power	Ground pin
C2	TST1	I	VDD	CMOS	Test pin. Pulled down by 100kΩ internal resistor. Keep this pin electrically non-connected or connect to VSS.
C3	TRG	I	VID	CMOS	External trigger pulse input pin. Enabled only in External trigger measurement mode. Pulled down by 100kΩ internal resistor. When External trigger measurement mode is not in use, keep this pin electrically non-connected or connect to VSS.
C4	VID	-	-	Power	Digital interface positive power supply pin.
D1	CAD0	I	VDD	CMOS	When the I2C bus interface is selected (CSB pin is connected to VID) CAD0:Slave address 0 input pin Connect to VSS or VDD.
					When the 4-wire serial interface is selected. Connect to VSS.
D2	CAD1	I	VDD	CMOS	When the I2C bus interface is selected (CSB pin is connected to VID). CAD1:Slave address 1 input pin Connect to VSS or VDD.
					When the 4-wire serial interface is selected. Connect to VSS.
D4	RSTN	I	VID	CMOS	Reset pin. Resets registers by setting to “L”. Connect to VID when not in use.

5. Overall Characteristics

5.1. Absolute Maximum Ratings

$V_{SS}=0V$

Parameter	Symbol	Min.	Max.	Unit
Power supply voltage (Vdd, Vid)	V+	-0.3	+4.3	V
Input voltage	VIN	-0.3	(V+)+0.3	V
Input current	IIN	-	±10	mA
Storage temperature	Tst	-40	+125	°C

(Note 1) If the device is used in conditions exceeding these values, the device may be destroyed.
Normal operations are not guaranteed in such exceeding conditions.

5.2. Recommended Operating Conditions

$V_{SS}=0V$

Parameter	Remark	Symbol	Min.	Typ.	Max.	Unit
Operating temperature		Ta	-30		+85	°C
Power supply voltage	VDD pin voltage	Vdd	1.7	3.0	3.6	V
	VID pin voltage	Vid	1.65		Vdd	V

5.3. Electrical Characteristics

The following conditions apply unless otherwise noted:

Vdd=1.7V to 3.6V, Vid=1.65V to Vdd, Temperature range=-30 °C to 85 °C

5.3.1. DC Characteristics

Parameter	Symbol	Pin	Condition	Min.	Typ.	Max.	Unit
High level input voltage 1	VIH1	CSB RSTN TRG		70%Vid			V
Low level input voltage 1	VIL1					30%Vid	V
High level input voltage 2	VIH2	SK/SCL SI/SDA		70%Vid		Vid+0.3	V
Low level input voltage 2	VIL2			-0.3V		30%Vid	V
High level input voltage 3	VIH3	CAD0 CAD1 TST1		70%Vdd			V
Low level input voltage 3	VIL3					30%Vdd	V
Input current 1	IIN1	SK/SCL SI/SDA CSB RSTN	Vin=Vss or Vid	-10		+10	μA
		CAD0 CAD1	Vin=Vss or Vdd	-10		+10	
Input current 2	IIN2	TRG	Vin=Vid			100	μA
Input current 3	IIN3	TST1	Vin=Vdd			100	μA
Hysteresis input voltage (Note 2)	VHS	SCL SDA	Vid≥2V	5%Vid			V
			Vid<2V	10%Vid			
High level output voltage 1	VOH1	SO DRDY TST2	IOH≥-100μA	80%Vid			V
Low level output voltage 1	VOL1			IOI≤+100μA			20%Vid
Low level output voltage 2 (Note 3)	VOL2	SDA	IOI≤+3mA Vid≥2V			0.4	V
			IOI≤+3mA Vid<2V			20%Vid	V

Current consumption (Note 4)	IDD1	VDD VID	Power-down mode Vdd=Vid=3.0V		3	6	μA
	IDD2		When magnetic sensor is driven		1.4	2.3	mA
	IDD3		Self-test mode		3.4	5	mA
	IDD4		When temperature sensor is driven		1	1.5	mA
	IDD5		(Note 5)		0.1	5	μA

(Note 2) Schmitt trigger input (reference value for design)

(Note 3) Output is open-drain. Connect a pull-up resistor externally

(Note 4) Without any resistance load

(Note 5) (case 1) Vdd=ON, Vid=ON, RSTN pin="L". (case 2) Vdd=ON, Vid=OFF (0V), RSTN pin="L". (case 3) Vdd=OFF (0V), Vid=ON.

5.3.2. AC Characteristics

Parameter	Symbol	Pin	Condition	Min.	Typ.	Max.	Unit
Power supply rise time (Note 6)	PSUP	VDD VID	Period of time that VDD (VID) changes from 0.2V to Vdd (Vid).			50	ms
POR completion time (Note 6)	PORT		Period of time after PSUP to Power-down mode(Note 7)			100	μs
Power supply turn off voltage (Note 6)	SDV	VDD VID	Turn off voltage to enable POR to restart(Note 7)			0.2	V
Power supply turn on interval (Note 6)	PSINT	VDD VID	Period of time that voltage lower than SDV needed to be kept to enable POR to restart(Note 7)	100			μs
Wait time before mode setting	Twat			100			μs
Wait time of Fuse ROM reading	Twatr		Wait time from Fuse ROM access mode setting to accessible Fuse ROM	100			μs

(Note 6) Reference value for design.

(Note 7) When POR circuit detects the rise of VDD/VID voltage, it resets internal circuits and initializes the registers. After reset, AK09912 transits to Power-down mode.

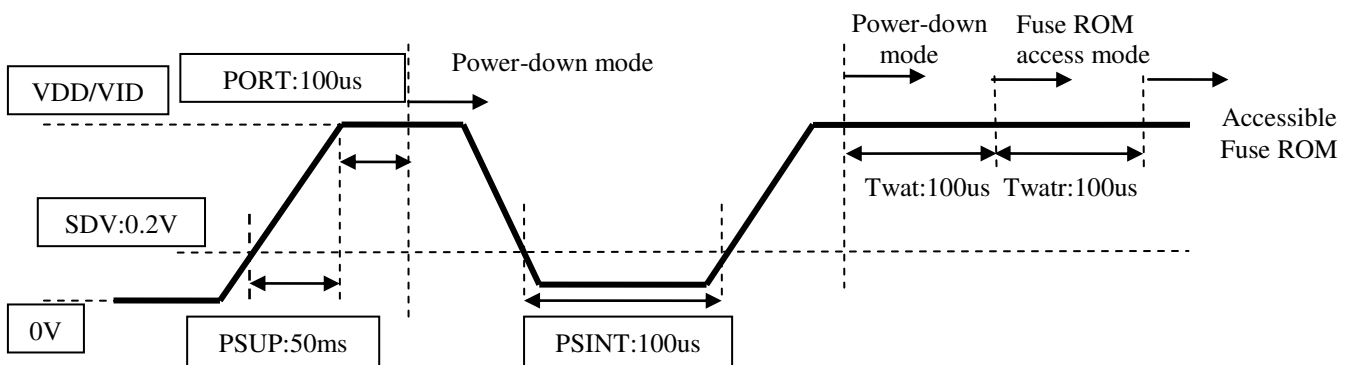

Parameter	Symbol	Pin	Condition	Min.	Typ.	Max.	Unit
Trigger input effective pulse width	tTRIGH	TRG		200			ns
Trigger input effective frequency (Note 8)	tTRIGf	TRG				100	Hz

(Note 8) The value when the period of time from the end of the measurement to the next trigger input is 1.3ms.

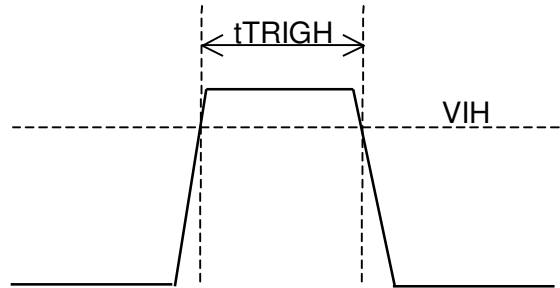

Parameter	Symbol	Pin	Condition	Min.	Typ.	Max.	Unit
Reset input effective pulse width ("L")	tRSTL	RSTN		5			μs

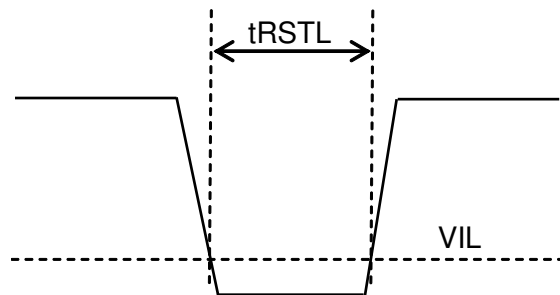

5.3.3. Analog Circuit Characteristics

Parameter	Symbol	Condition	Min.	Typ.	Max.	Unit
Measurement data output bit	DBIT		-	16	-	bit
Time for measurement	TSM	Single measurement mode		7.2	8.5	ms
Magnetic sensor sensitivity (Note 9)	BSE	Tc = 25 °C	0.1425	0.15	0.1575	μT/LSB
Magnetic sensor measurement range (Note 10)	BRG	Tc = 25 °C	±4912			μT
Magnetic sensor initial offset (Note 11)		Tc = 25 °C	-2000		+2000	LSB

(Note 9) Value after sensitivity is adjusted using sensitivity fine adjustment data stored in Fuse ROM.

(Note 10) Reference value for design

(Note 11) Value of measurement data register on shipment without applying magnetic field on purpose.

5.3.4. 4-wire SPI

4-wire SPI is compliant with mode 3 (SPI-mode3).

Parameter	Symbol	Condition	Min.	Typ.	Max.	Unit
CSB setup time	Tcs		50			ns
Data setup time	Ts		50			ns
Data hold time	Th		50			ns
SK high time	Twh	Vid≥2.5V	100			ns
		2.5V>Vid≥1.65V	150			ns
SK low time	Twl	Vid≥2.5V	100			ns
		2.5V>Vid≥1.65V	150			ns
SK setup time	Tsd		50			ns
SK to SO delay time (Note 12)	Tdd				50	ns
CSB to SO delay time (Note 12)	Tcd				50	ns
SK rise time (Note 13)	Tr				100	ns
SK fall time (Note 13)	Tf				100	ns
CSB high time	Tch		150			ns

(Note 12) SO load capacitance:20pF

(Note 13) Reference value for design.

[4-wire SPI]

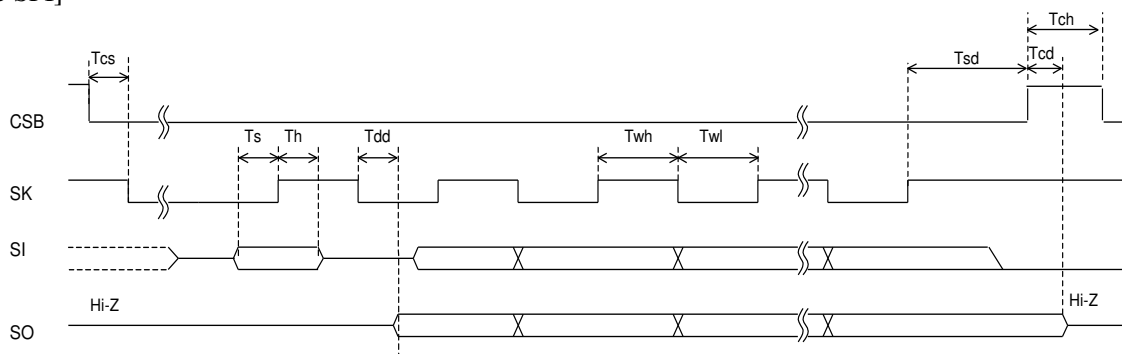

[Rise time and fall time]

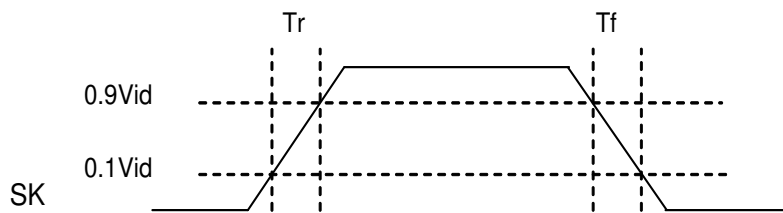

5.3.5. I²C Bus Interface

CSB pin = "H"

I²C bus interface is compliant with Standard mode and Fast mode. Standard/Fast mode is selected automatically by fSCL.

□ Standard mode

$f_{SCL} \leq 100\text{kHz}$

Symbol	Parameter	Min.	Typ.	Max.	Unit
fSCL	SCL clock frequency			100	kHz
tHIGH	SCL clock "High" time	4.0			μs
tLOW	SCL clock "Low" time	4.7			μs
tR	SDA and SCL rise time			1.0	μs
tF	SDA and SCL fall time			0.3	μs
tHD:STA	Start Condition hold time	4.0			μs
tSU:STA	Start Condition setup time	4.7			μs
tHD:DAT	SDA hold time (vs. SCL falling edge)	0			μs
tSU:DAT	SDA setup time (vs. SCL rising edge)	250			ns
tSU:STO	Stop Condition setup time	4.0			μs
tBUF	Bus free time	4.7			μs

□ Fast mode

$100\text{Hz} \leq f_{SCL} \leq 400\text{kHz}$

Symbol	Parameter	Min.	Typ.	Max.	Unit
fSCL	SCL clock frequency			400	kHz
tHIGH	SCL clock "High" time	0.6			μs
tLOW	SCL clock "Low" time	1.3			μs
tR	SDA and SCL rise time			0.3	μs
tF	SDA and SCL fall time			0.3	μs
tHD:STA	Start Condition hold time	0.6			μs
tSU:STA	Start Condition setup time	0.6			μs
tHD:DAT	SDA hold time (vs. SCL falling edge)	0			μs
tSU:DAT	SDA setup time (vs. SCL rising edge)	100			ns
tSU:STO	Stop Condition setup time	0.6			μs
tBUF	Bus free time	1.3			μs
tSP	Noise suppression pulse width			50	ns

[I²C bus interface timing]

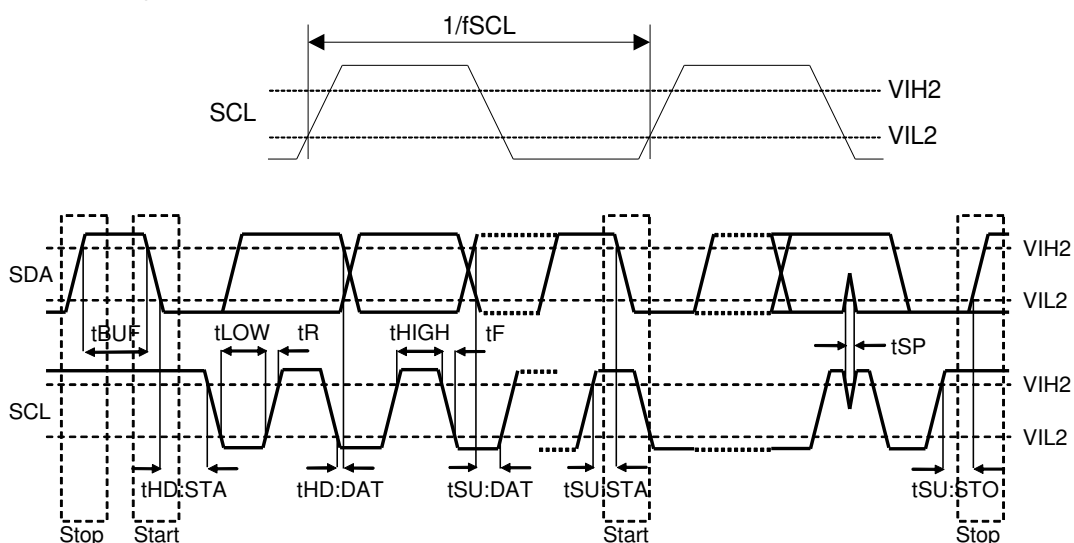

- High-speed mode (Hs-mode)
 - $C_b \leq 100\text{pF}$ (C_b : load capacitance)
 - $f\text{SCLH} \leq 2.5\text{MHz}$

Symbol	Parameter	Min.	Typ.	Max.	Unit
fSCLH	SCLH clock frequency			2.5	MHz
tHIGH	SCLH clock "High" time	110			ns
tLOW	SCLH clock "Low" time	220			ns
tR_CL	SCLH rise time	10		40	ns
tR_CL1	SCLH rise time after a repeated START condition and after an acknowledge bit	10		80	ns
tR_DA	SDAH rise time	10		80	ns
tF_CL	SCLH fall time	-		40	ns
tF_DA	SDAH fall time	-		80	ns
tHD:STA	Start Condition hold time	160			ns
tSU:STA	Start Condition setup time	160			ns
tHD:DAT	SDAH hold time (vs. SCLH falling edge)	0			ns
tSU:DAT	SDAH setup time (vs. SCLH rising edge)	10			ns
tSU:STO	Stop Condition setup time	160			ns
tSP	Noise suppression pulse width			10	ns

- $C_b \leq 400\text{pF}$
- $f\text{SCLH} \leq 1.7\text{MHz}$

Symbol	Parameter	Min.	Typ.	Max.	Unit
fSCLH	SCLH clock frequency			1.7	MHz
tHIGH	SCLH clock "High" time	120			ns
tLOW	SCLH clock "Low" time	320			ns
tR_CL	SCLH rise time	20		80	ns
tR_CL1	SCLH rise time after a repeated START condition and after an acknowledge bit	20		160	ns
tR_DA	SDAH rise time	20		160	ns
tF_CL	SCLH fall time	-		80	ns
tF_DA	SDAH fall time	-		160	ns
tHD:STA	Start Condition hold time	160			ns
tSU:STA	Start Condition setup time	160			ns
tHD:DAT	SDAH hold time (vs. SCLH falling edge)	0			ns
tSU:DAT	SDAH setup time (vs. SCLH rising edge)	10			ns
tSU:STO	Stop Condition setup time	160			ns
tSP	Noise suppression pulse width			10	ns

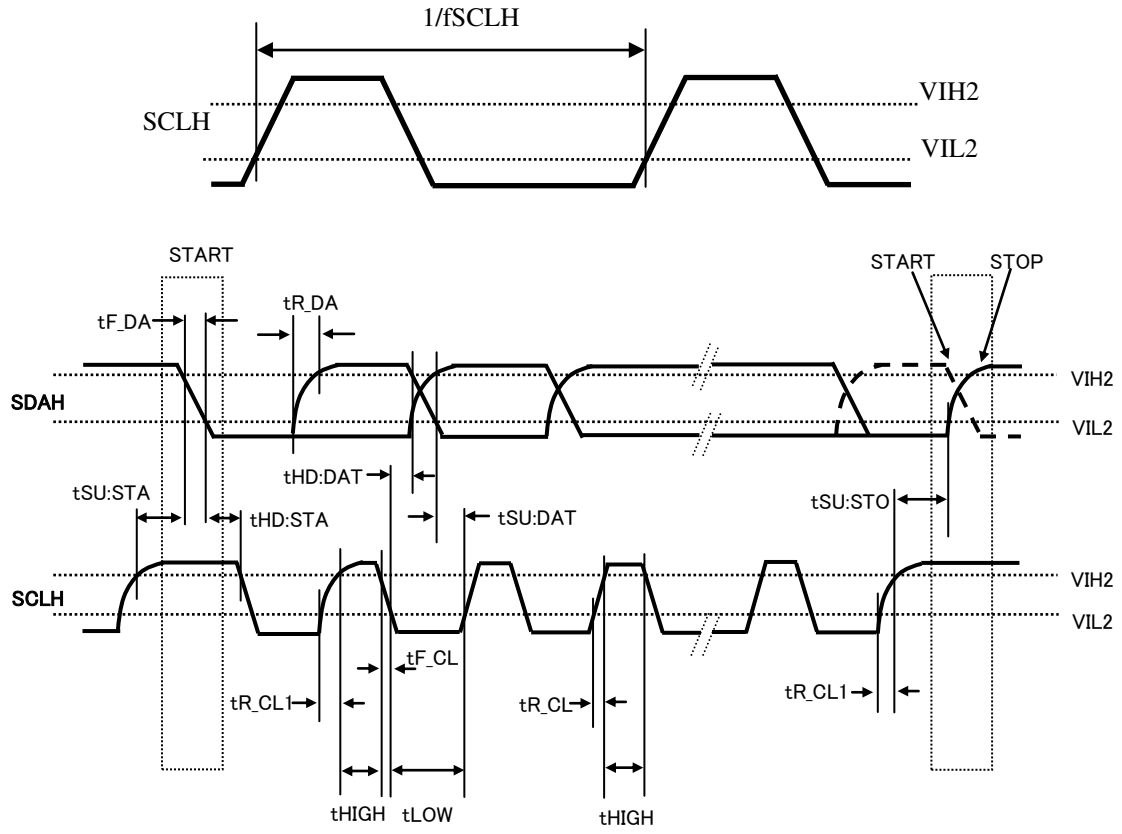

6. Function Explanation

6.1. Power States

When VDD and VID are turned on from Vdd=OFF (0V) and Vid=OFF (0V), all registers in AK09912 are initialized by POR circuit and AK09912 transits to Power-down mode.

All the states in the table below can be set, although the transition from state 2 to state 3 and the transition from state 3 to state 2 are prohibited.

Table 6.1 Power state

State	VDD	VID	Power state
1	OFF (0V)	OFF (0V)	OFF (0V). It doesn't affect external interface. Digital input pins other than SCL and SDA pin should be fixed to "L" (0V).
2	OFF (0V)	1.65V to 3.6V	OFF (0V) It doesn't affect external interface.
3	1.7V to 3.6V	OFF (0V)	OFF(0V) It doesn't affect external interface. Digital input pins other than SCL and SDA pin should be fixed to "L" (0V).
4	1.7V to 3.6V	1.65V to Vdd	ON

6.2. Reset Functions

When the power state is ON, always keep $Vid \leq Vdd$.

Power-on reset (POR) works until Vdd reaches to the operation effective voltage (about 1.1V: reference value for design) on power-on sequence. After POR is deactivated, all registers are initialized and transits to power down mode.

When Vdd=1.7 to 3.6V, POR circuit and VID monitor circuit are active. When Vid=0V, AK09912 is in reset status and it consumes the current of reset state (IDD5).

AK09912 has four types of reset;

- (1) Power on reset (POR)
When Vdd rise is detected, POR circuit operates, and AK09912 is reset.
- (2) VID monitor
When VID is turned OFF (0V), AK09912 is reset.
- (3) Reset pin (RSTN)
AK09912 is reset by Reset pin. When Reset pin is not used, connect to VID.
- (4) Soft reset
AK09912 is reset by setting SRST bit. When AK09912 is reset, all registers (without ASAX, ASAY and ASAZ) are initialized and AK09912 transits to Power-down mode.

6.3. Operation Mode

AK09912 has following nine operation modes:

- (1) Power-down mode
- (2) Single measurement mode
- (3) Continuous measurement mode 1
- (4) Continuous measurement mode 2
- (5) Continuous measurement mode 3
- (6) Continuous measurement mode 4
- (7) External trigger measurement mode
- (8) Self-test mode
- (9) Fuse ROM access mode

By setting CNTL2 register MODE[4:0] bits, the operation set for each mode is started.

A transition from one mode to another is shown below.

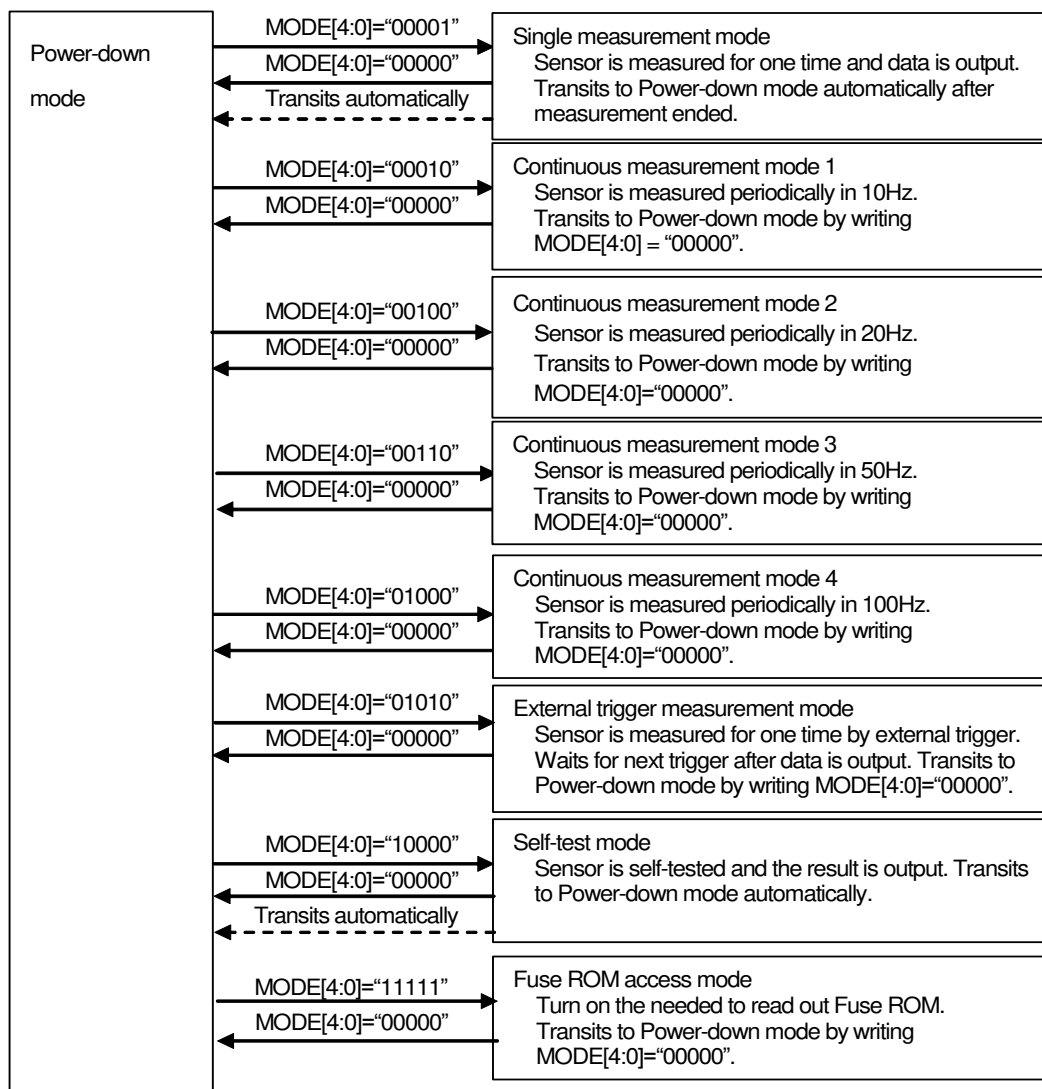

Figure 6.1 Operation mode

When power is turned ON, AK09912 is in Power-down mode. When a specified value is set to MODE[4:0], AK09912 transits to the specified mode and starts operation. When user wants to change operation mode, transit to power-down mode first and then transit to other modes. After Power-down mode is set, at least 100 μ s (T_{wat}) is needed before setting another mode.

6.4. Description of Each Operation Mode

6.4.1. Power-down Mode

Power to almost all internal circuits is turned off. All registers are accessible in Power-down mode. Data stored in read/write registers are remained. They can be reset by soft reset.

6.4.2. Single Measurement Mode

When Single measurement mode (MODE[4:0]="00001") is set, magnetic sensor measurement is started. After magnetic sensor measurement and signal processing is finished, measurement magnetic data is stored to measurement data registers (HXL to HZH), then AK09912 transits to Power-down mode automatically. On transition to Power-down mode, MODE[4:0] turns to "00000". When temperature sensor is enabled (TEM="1"), temperature sensor measurement is started together with magnetic sensor measurement and measurement temperature data is stored to measurement data registers (TMPS). At the same time, DRDY bit in ST1 register turns to "1". This is called "Data Ready". When any of measurement data register (HXL to TMPS) or ST2 register is read, DRDY bit turns to "0". It remains "1" on transition from Power-down mode to another mode. DRDY pin is in the same state as DRDY bit. (Figure 6.2)

When sensor is measuring (Measurement period), measurement data registers (HXL to TMPS) keep the previous data. Therefore, it is possible to read out data even in measurement period. Data read out in measurement period are previous data. (Figure 6.3)

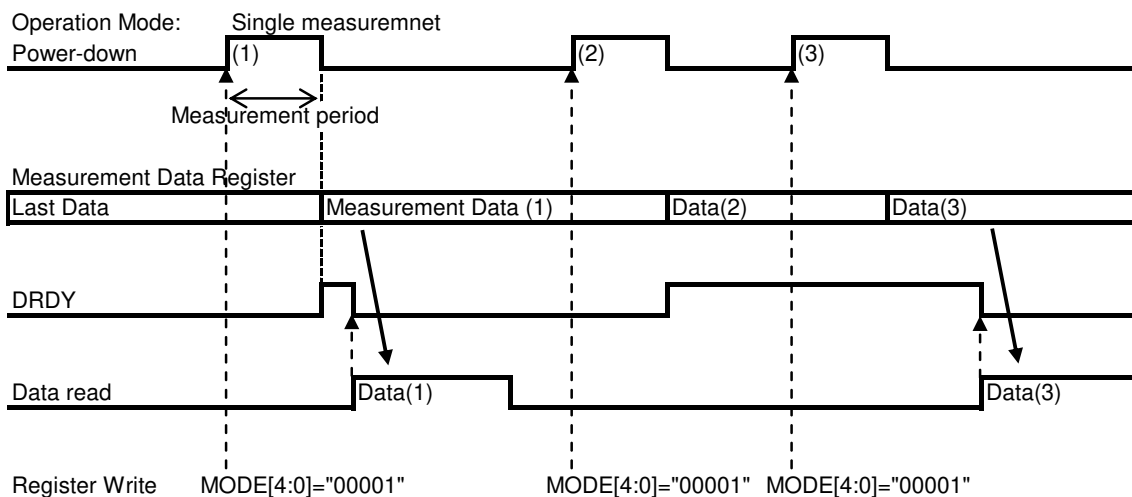

Figure 6.2 Single measurement mode when data is read out of measurement period

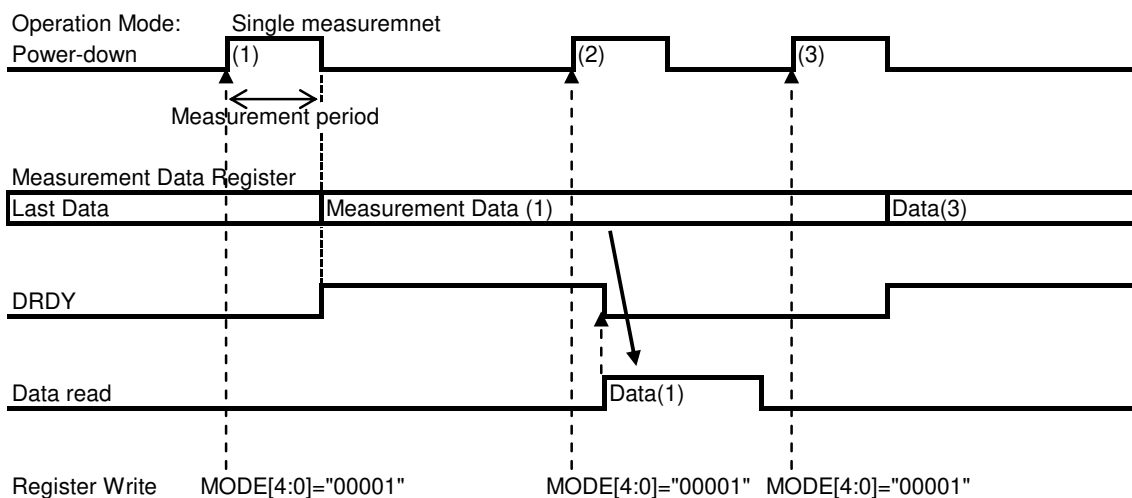

Figure 6.3 Single measurement mode when data read started during measurement period

6.4.3. Continuous Measurement Mode 1, 2, 3 and 4

When Continuous measurement mode 1 (MODE[4:0]="00010"), 2 (MODE[4:0]="00100"), 3 (MODE[4:0]="00110") or 4 (MODE[4:0]="01000") is set, magnetic sensor measurement is started periodically at 10 Hz, 20 Hz, 50 Hz or 100 Hz respectively. After magnetic sensor measurement and signal processing is finished, measurement magnetic data is stored to measurement data registers (HXL to HZH) and all circuits except for the minimum circuit required for counting cycle length are turned off (PD). When the next measurement timing comes, AK09912 wakes up automatically from PD and starts measurement again. When temperature sensor is enabled (TEM = "1"), temperature sensor measurement is started together with magnetic sensor measurement, and measurement temperature data is stored to measurement data registers (TMPS).

Continuous measurement mode ends when Power-down mode (MODE[4:0]="00000") is set. It repeats measurement until Power-down mode is set.

When Continuous measurement mode 1 (MODE[4:0]="00010"), 2 (MODE[4:0]="00100"), 3 (MODE[4:0]="00110") or 4 (MODE[4:0]="01000") is set again while AK09912 is already in Continuous measurement mode, a new measurement starts. ST1, ST2 and measurement data registers (HXL to TMPS) will not be initialized by this.

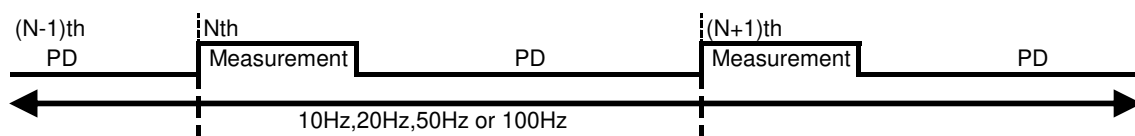

Figure 6.4 Continuous measurement mode

6.4.3.1. Data Ready

When measurement data is stored and ready to be read, DRDY bit in ST1 register turns to "1". This is called "Data Ready". DRDY pin is in the same state as DRDY bit. When measurement is performed correctly, AK09912 becomes Data Ready on transition to PD after measurement.

6.4.3.2. Normal Read Sequence

(1) Check Data Ready or not by any of the following method.

- Polling DRDY bit of ST1 register
- Monitor DRDY pin

When Data Ready, proceed to the next step.

(2) Read ST1 register (not needed when polling ST1)

- DRDY: Shows Data Ready or not. Not when “0”, Data Ready when “1”.
- DOR: Shows if any data has been skipped before the current data or not. There are no skipped data when “0”, there are skipped data when “1”.

(3) Read measurement data

When any of measurement data register (HXL to TMPS) or ST2 register is read, AK09912 judges that data reading is started. When data reading is started, DRDY bit and DOR bit turns to “0”.

(4) Read ST2 register (required)

- HOFL: Shows if magnetic sensor is overflowed or not. “0” means not overflowed, “1” means overflowed.

When ST2 register is read, AK09912 judges that data reading is finished. Stored measurement data is protected during data reading and data is not updated. By reading ST2 register, this protection is released. It is required to read ST2 register after data reading.

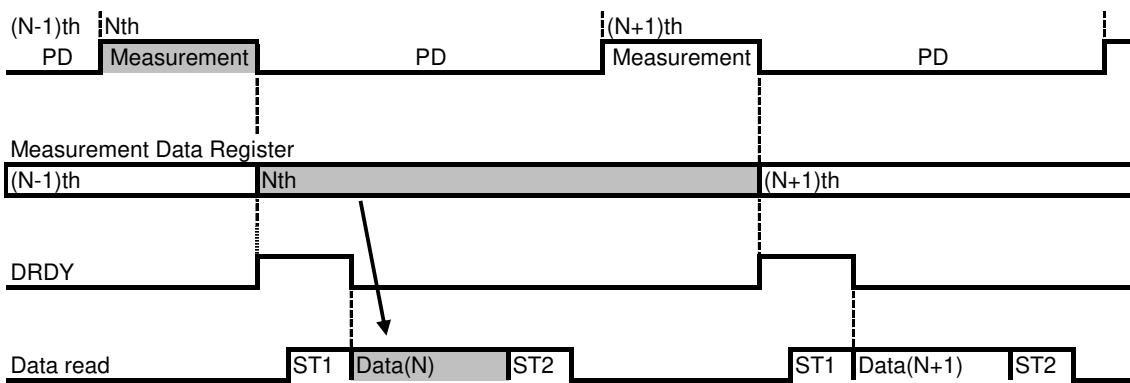

Figure 6.5 Normal read sequence

6.4.3.3. Data Read Start during Measurement

When sensor is measuring (Measurement period), measurement data registers (HXL to TMPS) keep the previous data. Therefore, it is possible to read out data even in measurement period. If data is started to be read during measurement period, previous data is read.

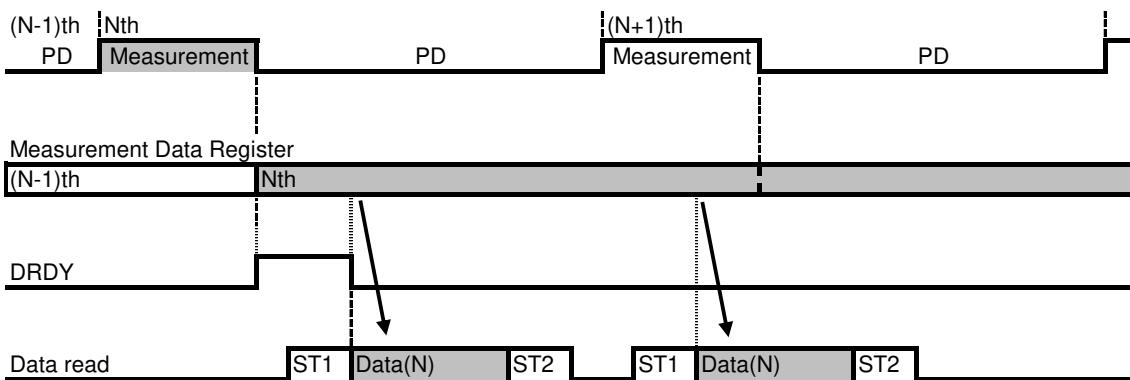

Figure 6.6 Data read start during measurement

6.4.3.4. Data Skip

When Nth data was not read before (N+1)th measurement ends, Data Ready remains until data is read. In this case, a set of measurement data is skipped so that DOR bit turns to “1”.

When data reading started after Nth measurement ended and did not finish reading before (N+1)th measurement ended, Nth measurement data is protected to keep correct data. In this case, a set of measurement data is skipped and not stored so that DOR bit turns to “1”.

In both case, DOR bit turns to “0” at the next start of data reading.

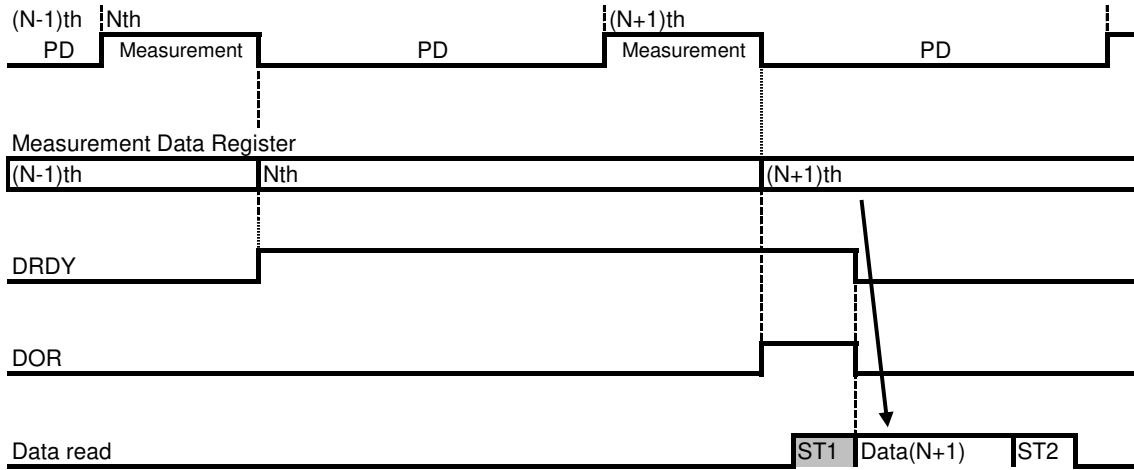

Figure 6.7 Data Skip: When data is not read

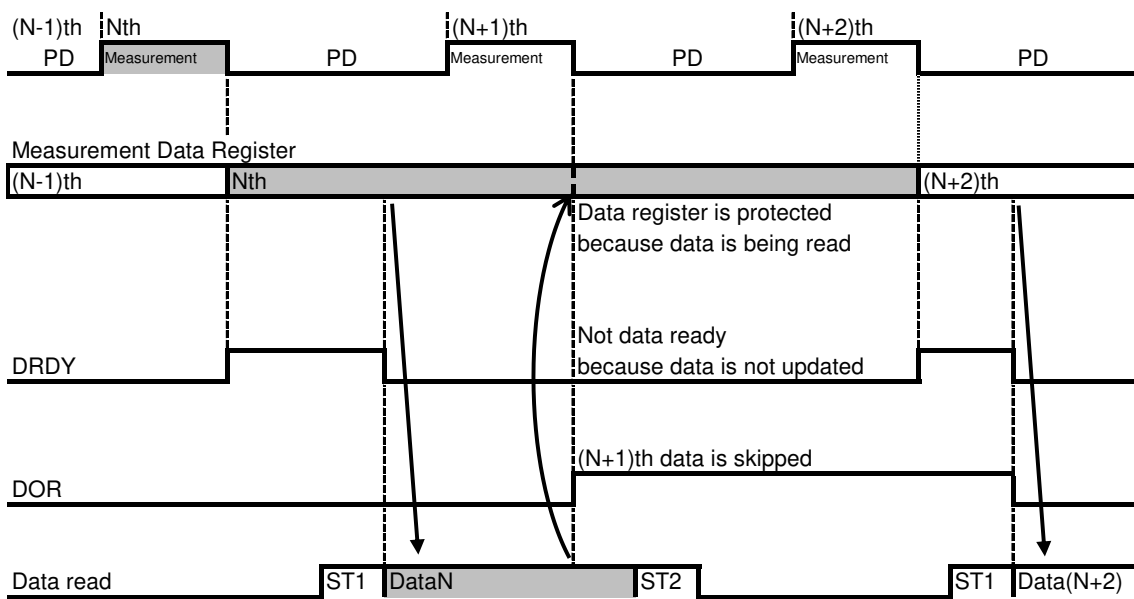

Figure 6.8 Data Skip: When data read has not been finished before the next measurement end

6.4.3.5. End Operation

Set Power-down mode (MODE[4:0]=“0000”) to end Continuous measurement mode.

6.4.3.6. Magnetic Sensor Overflow

AK09912 has the limitation for measurement range that the sum of absolute values of each axis should be smaller than 4912 μT .

$$|X|+|Y|+|Z| < 4912 \mu\text{T}$$

When the magnetic field exceeded this limitation, data stored at measurement data are not correct. This is called Magnetic Sensor Overflow.

When magnetic sensor overflow occurs, HOFL bit turns to "1". When the next measurement starts, it returns to "0".

6.4.4. External Trigger Measurement Mode

When External trigger measurement mode (MODE[4:0]="01010") is set, AK09912 waits for trigger input. When a pulse is input from TRG pin, magnetic sensor measurement is started on the rising edge of TRG pin. After magnetic sensor measurement and signal processing is finished, measurement magnetic data is stored to measurement data registers (HXL to HZH) and all circuits except for the minimum circuit required for trigger input waiting are turned off (PD state). When the next pulse is input, AK09912 wakes up automatically from PD and starts measurement again.

When temperature sensor is enabled (TEM="1"), temperature sensor measurement is started together with magnetic sensor measurement, and measurement temperature data is stored to measurement data registers (TMPS).

When power-down mode (MODE[4:0]="00000") is set, External trigger measurement mode ends. AK09912 keeps waiting for the trigger input until the Power-down mode is set.

When External trigger measurement mode (MODE[4:0]="01010") is set again while AK09912 is already in External trigger measurement mode, it starts to wait for the trigger input again. The trigger input is ignored while sensor is measuring.

Data read sequence and functions of read-only registers in External trigger measurement mode are the same as Continuous measurement mode.

6.4.5. Self-test Mode

Self-test mode is used to check if the magnetic sensor is working normally.

When Self-test mode (MODE[4:0]="10000") is set, magnetic field is generated by the internal magnetic source and magnetic sensor is measured. Measurement data is stored to measurement data registers (HXL to HZH), then AK09912 transits to Power-down mode automatically. (Temperature sensor is not measured.)

Data read sequence and functions of read-only registers in Self-test mode are the same as Single measurement mode.

6.4.5.1. Self-test Sequence

- (1) Set Power-down mode. (MODE[4:0]="00000")
- (2) Set Self-test mode. (MODE[4:0]="10000")
- (3) Check Data Ready or not by any of the following method.
 - Polling DRDY bit of ST1 register
 - Monitor DRDY pin

When Data Ready, proceed to the next step.

- (4) Read measurement data (HXL to HZH)

6.4.5.2. Self-test Judgment

When measurement data read by the above sequence is in the range of following table after sensitivity adjustment (refer to 8.3.13), AK09912 is working normally.

	HX[15:0]	HY[15:0]	HZ[15:0]
Criteria	$-200 \leq \text{HX} \leq +200$	$-200 \leq \text{HY} \leq +200$	$-1600 \leq \text{HZ} \leq -400$

6.4.6. Fuse ROM Access Mode

Fuse ROM access mode is used to read Fuse ROM data. Sensitivity adjustment data for each axis is stored in Fuse ROM. Set Fuse ROM Access mode (MODE[4:0]="11111") before reading Fuse ROM data. When Fuse ROM Access mode is set, circuits required for reading Fuse ROM are turned on. However, it needs 100 μs (T_{watr}) to read Fuse ROM after mode setting.

After reading Fuse ROM data, set Power-down mode (MODE[4:0]="00000") before the transition to another mode.

6.5. Temperature Sensor

In Single measurement mode, Continuous measurement mode 1, 2, 3, 4, or External trigger measurement mode is set, AK09912 can measure temperature sensor together with magnetic sensor. When temperature sensor is enabled (TEM = "1"), temperature sensor measurement is started together with magnetic sensor measurement. In Continuous measurement mode 1, 2, 3 or 4, temperature sensor measurement is started at every 8 measurements of magnetic sensor measurement. In Single measurement mode or External trigger measurement mode, temperature sensor measurement is started at every measurement of magnetic sensor measurement. When user wants to change temperature sensor measurement enables or disables, set to Power-down mode is required before change temperature sensor measurement. Default TEM register is "disable" (TEM="0").

6.6. Noise Suppression Filter (NSF)

In Single measurement mode, Continuous measurement mode 1, 2, 3, 4 or External trigger measurement mode, output from the magnetic sensor can be filtered to suppress the noise. This filter name is Noise Suppression Filter (NSF). There are three optional filter extents. When NSF[1:0] = "00", NSF is "disable" and output magnetic data is not filtered. When NSF[1:0] = "01", NSF extent is "Low" and output magnetic data is filtered mildly. When NSF[1:0] = "10", NSF extent is "Middle" and output magnetic data is filtered moderately. When NSF[1:0] = "11", NSF extent is "High" and output magnetic data is filtered strongly.

NSF register can be changed in Power-down mode only.

Default NSF register is "disable" (NSF[1:0] = "00").

7. Serial Interface

AK09912 supports I²C bus interface and 4-wire SPI. A selection is made by CSB pin. When used as 3-wire SPI, set SI pin and SO pin wired-OR externally.

CSB pin="L": 4-wire SPI
 CSB pin="H": I2C bus interface

7.1. 4-wire SPI

The 4-wire SPI consists of four digital signal lines: SK, SI, SO, and CSB, and is provided in 16bit protocol. Data consists of Read/Write control bit (R/W), register address (7-bit) and control data (8-bit). To read out all axes measurement data (X, Y, Z), an option to read out more than one byte data using automatic increment command is available. (Sequential read operation)

CSB pin is low active. Input data is taken in on the rising edge of SK pin, and output data is changed on the falling edge of SK pin. (SPI-mode3)

Communication starts when CSB pin transits to "L" and stops when CSB pin transits to "H". SK pin must be "H" during CSB pin is in transition. Also, it is prohibited to change SI pin during CSB pin is "H" and SK pin is "H".

7.1.1. Writing Data

Input 16 bits data on SI pin in synchronous with the 16-bit serial clock input on SK pin. Out of 16 bits input data, the first 8 bits specify the R/W control bit (R/W="0" when writing) and register address (7-bit), and the latter 8 bits are control data (8-bit). When any of addresses listed on Table 8.1 is input, AK09912 recognizes that it is selected and takes in latter 8 bits as setting data.

If the number of clock pulses is less than 16, no data is written. If the number of clock pulses is more than 16, data after the 16th clock pulse on SI pin are ignored.

It is not compliant with serial write operation for multiple addresses.

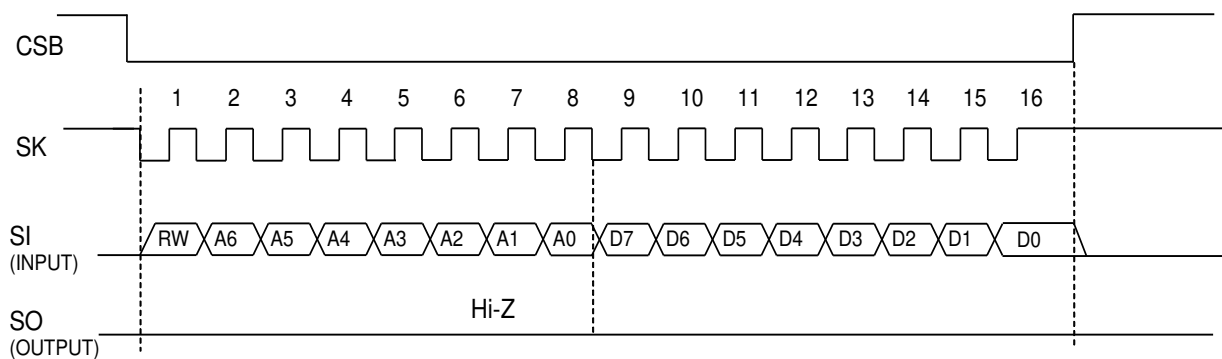

Figure 7.1 4-wire SPI Writing Data

7.1.2. Reading Data

Input the R/W control bit (R/W="1") and 7-bit register address on SI pin in synchronous with the first 8 bits of the 16 bits of a serial clock input on SK pin. Then AK09912 outputs the data held in the specified register with MSB first from SO pin.

When clocks are input continuously after one byte of data is read, the address is incremented and data in the next address is output. Accordingly, after the falling edge of the 15th clock and CSB pin is "L", the data in the next address is output on SO pin. When CSB pin is driven "L" to "H", SO pin is placed in the high-impedance state.

AK09912 has two incrimination lines; 00H to 18H and 30H to 32H. For example, data is read as follows: 00H → 01H → 02H → 03H → 10H → 11H ... → 18H → 00H → 01H ..., 30H → 31H → 32H → 30H ..., or 60H → 61H → 62H → 60H

...

33H to 35H and 37H are reserved addresses. Do not access to those addresses.

When specified address is other than 00H to 18H, 30H to 37H and 60H to 62H, AK09912 recognizes that it is not selected and keeps SO pin in high-impedance state. Therefore, user can use other addresses for other devices.

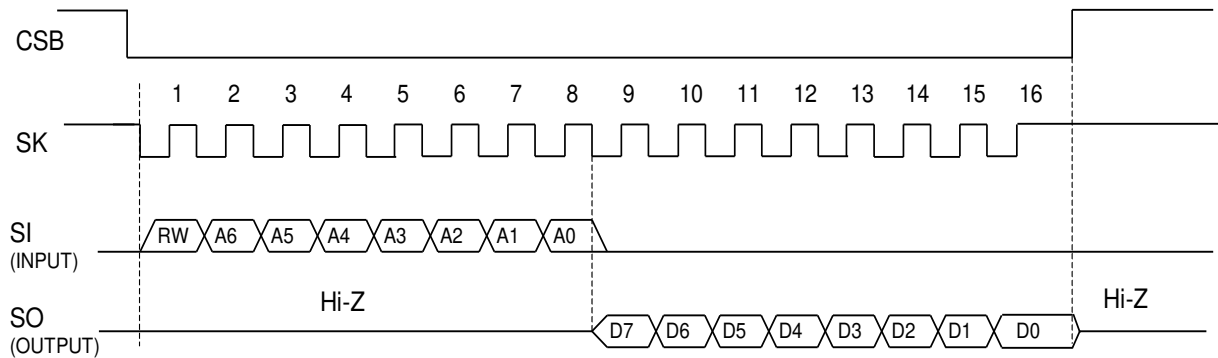

Figure 7.2 4-wire SPI Reading Data

7.2. I²C Bus Interface

The I²C bus interface of AK09912 supports the Standard mode (100 kHz max.), the Fast mode (400 kHz max.) and High-speed mode (Hs-mode, 2.5 MHz max.).

7.2.1. Data Transfer

To access AK09912 on the bus, generate a start condition first.

Next, transmit a one-byte slave address including a device address. At this time, AK09912 compares the slave address with its own address. If these addresses match, AK09912 generates an acknowledgement, and then executes READ or WRITE instruction. At the end of instruction execution, generate a stop condition.

7.2.1.1. Change of Data

A change of data on the SDA line must be made during “Low” period of the clock on the SCL line. When the clock signal on the SCL line is “High”, the state of the SDA line must be stable. (Data on the SDA line can be changed only when the clock signal on the SCL line is “Low”.)

During the SCL line is “High”, the state of data on the SDA line is changed only when a start condition or a stop condition is generated.

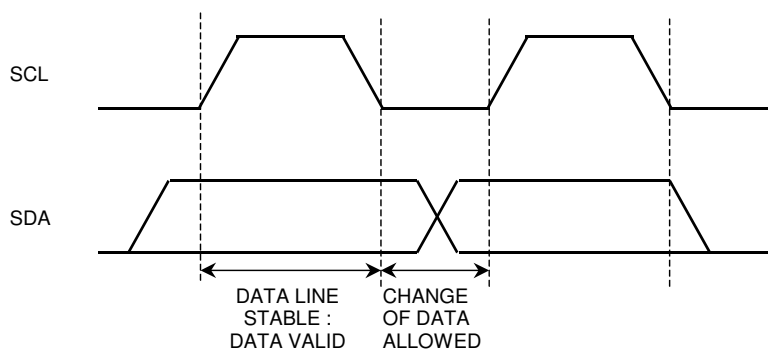

Figure 7.3 Data Change

7.2.1.2. Start/Stop Condition

If the SDA line is driven to “Low” from “High” when the SCL line is “High”, a start condition is generated. Every instruction starts with a start condition.

If the SDA line is driven to “High” from “Low” when the SCL line is “High”, a stop condition is generated. Every instruction stops with a stop condition.

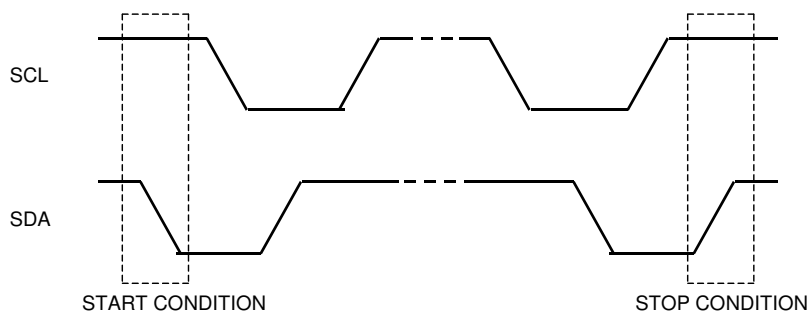

Figure 7.4 Start and Stop Condition

7.2.1.3. Acknowledge

The IC that is transmitting data releases the SDA line (in the “High” state) after sending 1-byte data. The IC that receives the data drives the SDA line to “Low” on the next clock pulse. This operation is referred as acknowledge. With this operation, whether data has been transferred successfully can be checked. AK09912 generates an acknowledge after reception of a start condition and slave address. When a WRITE instruction is executed, AK09912 generates an acknowledge after every byte is received. When a READ instruction is executed, AK09912 generates an acknowledge then transfers the data stored at the specified address. Next, AK09912 releases the SDA line then monitors the SDA line. If a master IC generates an acknowledge instead of a stop condition, AK09912 transmits the 8-bit data stored at the next address. If no acknowledge is generated, AK09912 stops data transmission.

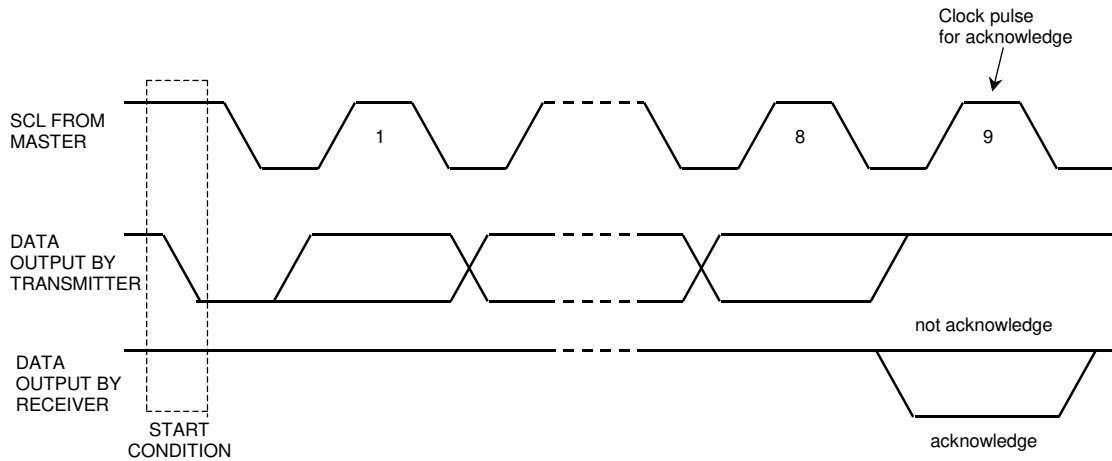

Figure 7.5 Generation of Acknowledge

7.2.1.4. Slave Address

The slave address of AK09912 can be selected from the following list by setting CAD0/1 pin. When CAD pin is fixed to VSS, the corresponding slave address bit is “0”. When CAD pin is fixed to VDD, the corresponding slave address bit is “1”.

Table 7.1 Slave Address and CAD0/1 pin

CAD1	CAD0	Slave Address
0	0	0CH
0	1	0DH
1	0	0EH
1	1	0FH

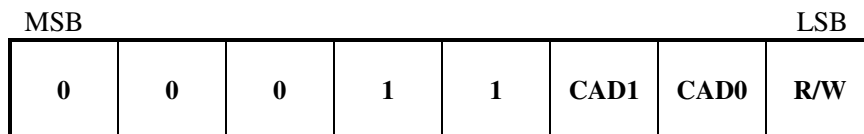

Figure 7.6 Slave Address

The first byte including a slave address is transmitted after a start condition, and an IC to be accessed is selected from the ICs on the bus according to the slave address. When a slave address is transferred, the IC whose device address matches the transferred slave address generates an acknowledge then executes an instruction. The 8th bit (least significant bit) of the first byte is a R/W bit. When the R/W bit is set to “1”, READ instruction is executed. When the R/W bit is set to “0”, WRITE instruction is executed.