



Chipsmall Limited consists of a professional team with an average of over 10 year of expertise in the distribution of electronic components. Based in Hongkong, we have already established firm and mutual-benefit business relationships with customers from,Europe,America and south Asia,supplying obsolete and hard-to-find components to meet their specific needs.

With the principle of "Quality Parts,Customers Priority,Honest Operation,and Considerate Service",our business mainly focus on the distribution of electronic components. Line cards we deal with include Microchip,ALPS,ROHM,Xilinx,Pulse,ON,Everlight and Freescale. Main products comprise IC,Modules,Potentiometer,IC Socket,Relay,Connector.Our parts cover such applications as commercial,industrial, and automotives areas.

We are looking forward to setting up business relationship with you and hope to provide you with the best service and solution. Let us make a better world for our industry!



Contact us

Tel: +86-755-8981 8866 Fax: +86-755-8427 6832

Email & Skype: info@chipsmall.com Web: www.chipsmall.com

Address: A1208, Overseas Decoration Building, #122 Zhenhua RD., Futian, Shenzhen, China





AK2346B

Two-way Radio Audio Processor

1. Features

- Audio processing
 - TX and RX amplifier
 - Pre/De-emphasis circuit
 - Compressor and Expander with no external components
 - Scrambler and De-scrambler in frequency inversion type
 - Limiter with level adjuster
 - Splatter filter for wide and narrow band
 - Digital controlled amplifier for microphone, modulator and demodulator sensitivity
- 1200/2400bps MSK MODEM with frame detection
- Wide range operation voltage: 1.9V to 5.5V, temperature: -30 to 75 °C
- Oscillator circuit for 3.6864MHz crystal
- Serial control interface operation
- Compact plastic packaging, 24-pin SSOP

2. Description

AK2346B includes audio filter, limiter, splatter filter, COMPANDOR, scrambler, MSK MODEM, which is highly integrated two-way radio baseband functions for FRS and LMR.

Audio high-pass filter shows a high attenuation in magnitude response characteristics under 250Hz that supports to eliminate a subaudio tone clearly.

TX limiter for deviation control has a limiting level adjuster by applying a DC voltage via external components. Splatter filter has the magnitude response for narrowband($f_c=2.55\text{kHz}$) and wideband(3.0kHz) to meet various regulatory agencies in the world wide.

COMPANDOR is no adjustment type because it includes all parametric components inside the chip. Scrambler circuit is composed of frequency inversion circuit by double balanced mixer that has 3.388kHz carrier clock.

MSK MODEM for data communication can be chosen either 2400bps or 1200bps. 2400bps data rate provides a high speed data transmission and 1200bps supports a low BER(bit error rate) performance that is suitable for under weak electrical field condition application.

There are four signal level adjusters for microphone, modulator and demodulator sensitivity by digital controlled amplifier (volume).

- Pin Assignment

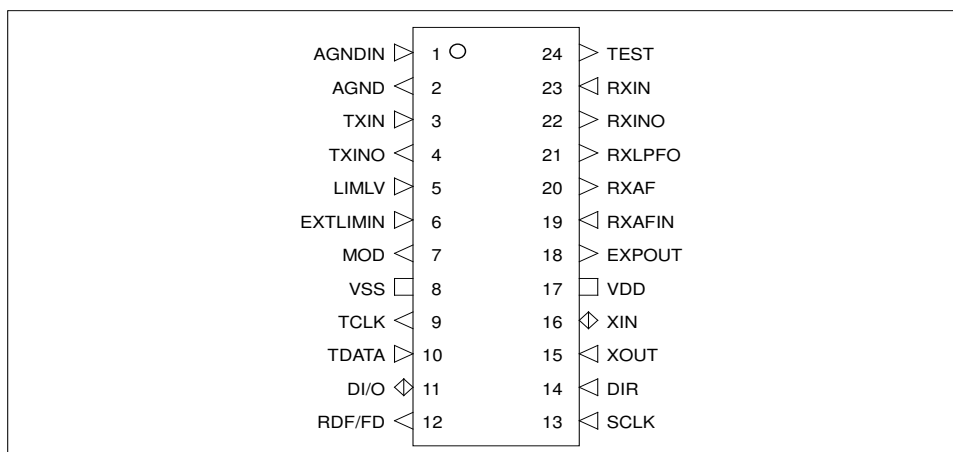

3. Contents

1. Features.....	1
2. Description.....	1
3. Contents	2
4. Block Diagram	3
5. Circuit Configuration	4
6. Pin/Function.....	5
7. Absolute Maximum Ratings	7
8. Recommended Operating Conditions.....	7
9. Digital DC characteristics.....	7
10. Power Consumption.....	8
11. Analog characteristics.....	9
12. Level Diagram.....	14
13. Serial Interface Configuration	15
14. Digital AC timing	20
15. MSK MODEM Description	23
16. Recommended External Application Circuits	26
17. Packaging	30
18. Important Notice.....	31

4. Block Diagram

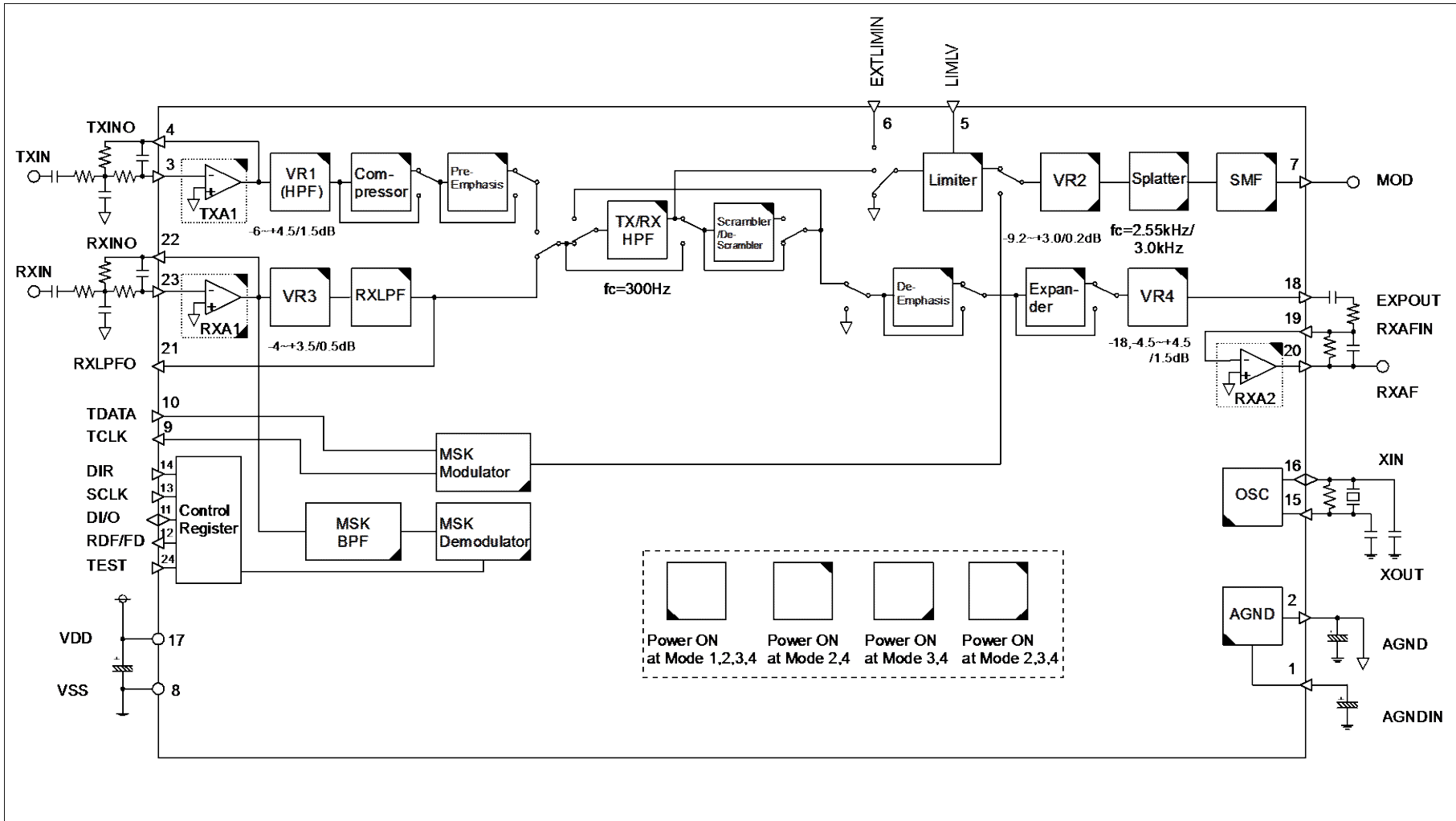

5. Circuit Configuration

Block	Description
TXA1	The operational amplifier for transmit audio gain adjustment and for the filter to eliminate aliasing noise by the SCF (switched capacitor filter) in the following stage. Please select an external resistor and capacitor to set the gain less than 30dB and the cut-off frequency to about 10kHz.
VR1 (HPF)	Digitally controlled amplifier (volume) for transmit audio signal level which is adjustable in 1.5dB steps over a -6.0dB to +4.5dB range by setting VR12 to VR10 register.
Compressor	The circuit to compress transmits audio signal level by 1/2 in dB scale. Standard cross-point is -10dBx. TC register sets OFF/ON to the circuit.
Pre-emphasis	The circuit to emphasis the high-frequency component of transmit audio signal to improve S/N ratio of the modulation signal.
TX/RXHPF	The High-pass filter to eliminate the low-frequency component less than 250Hz for transmit and receive audio signal.
Scrambler/Descrambler	Scramble/De-scramble circuit to inverse transmit and receive audio spectrum by 3.388kHz carrier signal. EM and PCONT register can set scramble/De-scramble or Emphasis circuit. Both circuits do not use simultaneously.
Limiter	An amplitude limiting circuit to suppress the frequency deviation of the modulation signal. The limitation level can be adjusted by applying a DC voltage to the LIMLV pin. If the LIMLV pin is open, the limitation level is applied to a predetermined level.
Splatter	The circuit to eliminate the high frequency component higher than 3kHz included in the limiter output signal or the MSK modulator signal. The cut-off frequency can be selected by SPL register.
VR2	Digitally controlled amplifier (volume) for MOD output level which is adjustable in 0.2dB steps over a -3.2dB to +3.0dB range by setting VR25 to VR20 register. VR25 is a -6/0dB coarse bit.
SMF	The smoothing filter to eliminate the high frequency and clock component caused in SCF circuits.
RXA1	The operational amplifier for receives audio gain adjustment and for the filter to eliminate aliasing noise by the SCF in the following stage. Please select an external resistor and capacitor to set the gain less than 20dB and the cut-off frequency to about 40kHz.
VR3	Digitally controlled amplifier (volume) for receive audio signal level which is adjustable in 0.5dB steps over a -4.0dB to +3.5dB range by setting VR33 to VR30 register.
RXLPF	The Low-pass filter to eliminate the high frequency component higher than 3kHz for receive audio signal.
De-emphasis	The circuit to de-emphasis the emphasized signal by pre-emphasis circuit.
Expander	The circuit to expand the receive audio signal level to double in dB scale compressed by compressor. Standard cross-point is -10dBx. TC register sets OFF/ON to the circuit.
VR4	Digitally controlled amplifier (volume) for EXPOUT output level which is adjustable in 1.5dB, steps over a -18dB and -4.5dB to +4.5dB range by setting VR42 to VR40 register.
RXA2	The operational amplifier used on smoothing filter to eliminate clock component included in EXPOUT output signal. Please set the gain to 0dB and the cut-off frequency to about 20kHz by external resistor and capacitor.
MSK Modulator	The circuit to generate a MSK signal according to the received digital data from TDATA pin.
MSK BPF	The Band-pass filter to eliminate the low and high frequency component for received MSK signal.
MSK Demodulator	The circuit to reproduce the 1200/2400bps receive clock and data from MSK signal at RXIN pin.

Block	Description
AGND	The circuit to generate the reference voltage (1/2VDD) for internal analog signal.
OSC	The circuit to oscillate the 3.6864MHz reference clock with an external crystal oscillator and resistor and capacitors.
Control Register	The control register controls the status of internal switches and digitally controlled amplifiers of IC by serial data that consists of 3 address bits and 8 data bits. At the start up a power-on-reset circuit works and "Reset" data are set to the control register. (Refer to the control register map) The data buffer stores 8 bits of the MSK received data to smooth the signal interface with microprocessor.

6. Pin/Function

Package Pin No	Signal		Function
	Name	Type	
1	AGNDIN	I	Analog ground input pin. Connect the capacitor to stabilize the analog ground level. This pin also has reset function for the registers. Connecting to the low level, "Reset" data are set to the control register.
2	AGND	O	Analog ground output pin. Connect the capacitor to stabilize the analog ground level.
3	TXIN	I	Transmit audio signal input pin. This is the inverting input pin for TXA1. It composes a microphone amplifier with an external resistor and capacitor.
4	TXINO	O	TXA1 feedback output pin.
5	LIMLV	I	Limit level adjuster pin. A limit level can be adjusted by applying a DC voltage to this pin. If it is open, the level is fixed to a predetermined level.
6	EXTLIMIN	I	External signal input pin pre-limiter circuit. This pin is available for external tone signal.
7	MOD	O	The modulated transmit signal output pin. Load impedance larger than 10kΩ can be drive.
8	VSS	PWR	Negative power supply pin. Normally supply 0V to this pin.
9	TCLK	O	Clock output pin for MSK transmission data. Setting the register named TXSW2 to "0" puts out 1.2/2.4kHz clock. If the register is set to "1", it goes to High level.
10	TDATA	I	MSK transmission data input pin. Data are latched synchronizing with the TCLK rising edge.
11	DI/O	I/O	Serial data input and output pin. Input for register setting data and output for MSK receive data.
12	RDF/FD	O	MSK signal received flag and frame detection signal output pin. This pin puts out two types of signal that depends on the status of register named FSL. In case FSL equal "1", it is received flag mode (RDF). So the pin puts out low level after 8 bits of MSK receive signal have been written to the internal register. In case FSL equal "0", it is frame detection mode (FD). So the low pulse is put out after a frame pattern is detected.

Package	Signal		Function	
	Pin No	Name		Type
	13	SCLK	I	Clock input pin for serial data I/O.
	14	DIR	I	Serial data I/O control pin.
	15	XOUT	I	Crystal oscillator connecting input pin.
	16	XIN	I/O	Crystal oscillator connecting input and output pin. To connect a 3.6864MHz crystal oscillator between this pin and XOUT pin generates the reference clock internally. In case of externally supplied clock operation, connect to this pin. For more information, please refer to external application circuits.
	17	VDD	PWR	Positive power supply pin. Normally connect to 1.9V to 5.5V noiseless power-supply. Also this pin must be decoupled to VSS pin by 0.1uF capacitor mounted close to the device pins.
	18	EXPOUT	O	Expander and VR4 output pin.
	19	RXAFIN	I	Receive audio signal input pin. This is the inverting input of RXA2. It composes a smoothing filter by external resistor and capacitor.
	20	RXAF	O	Receive audio signal output pin. This is the output pin of RXA2. Load impedance more than 10kΩ can be driven.
	21	RXLPFO	O	Receive LPF output pin. This is a monitor pin for tone signal. 57.6kHz sampling-clock is included, so please eliminate this signal component by LPF externally. Load impedance more than 10kΩ can be driven.
	22	RXINO	O	RXA1 feedback output pin.
	23	RXIN	I	Demodulated audio signal input pin. This is the inverting input of RXA1. It composes a pre-filter with external resistor and capacitor.
	24	TEST	I	Test register control input pin. When this pin set to high level, test register is controllable. Please set to low level or open for normal operation.

7. Absolute Maximum Ratings

Parameter	Symbol	Min.	Max.	Units
Power Supply Voltage	VDD	-0.3	6.5	V
Ground Level	VSS	0	0	V
Input Voltage	V _{IN}	-0.3	VDD+0.3	V
Input Current (Except power supply pin)	I _{IN}	-10	+10	mA
Storage Temperature	T _{stg}	-55	130	°C

Note : All voltages with respect to the VSS pin.

Caution : Exceeding these maximum ratings can result in damage to the device.
Normal operation cannot be guaranteed under this extreme.

8. Recommended Operating Conditions

Parameter	Symbol	Condition	Min.	Typ.	Max.	Units
Operating Temperature	T _a		-30		75	°C
Power Supply Voltage	VDD		1.9	3.0	5.5	V
Analog Reference Voltage	AGND			1/2VDD		V
Output Load Resistance	R _{L1}	MOD, RXAF, RXLPFO	10			kΩ
	R _{L2}	TXINO, RXINO, EXPOUT	30			
Output Load Capacitance	C _{L1}	MOD, RXAF, RXLPFO			50	pF
	C _{L2}	TXINO, RXINO, EXPOUT			15	
Master Clock Frequency	F _{CK}	XIN, XOUT		3.6864		MHz

Note : All voltages with respect to the VSS pin.

9. Digital DC characteristics

Parameter	Symbol	Condition	Min.	Typ.	Max.	Units
High level input voltage	V _{IH1}	TDATA, DI/O	0.7VDD			V
	V _{IH2}	SCLK, DIR	0.8VDD			
Low level input voltage	V _{IL1}	TDATA, DI/O			0.3VDD	V
	V _{IL2}	SCLK, DIR			0.2VDD	
High level input current	I _{IH}	V _{IH} =VDD TDATA, DI/O, SCLK, DIR			10	μA
Low level input current	I _{IL}	V _{IL} =0V TDATA, DI/O, SCLK, DIR	-10			μA
High level output voltage	V _{OH}	I _{OH} =+0.2mA TCLK, RDF/FD, DI/O	VDD-0.4		VDD	V
Low level output voltage	V _{OL}	I _{OL} =-0.4mA TCLK, RDF/FD, DI/O	0.0		0.4	V

10. Power Consumption

Parameter	Symbol	Condition	Min.	Typ.	Max.	Units
Current Consumption	IDD0	Mode 0 OSC:OFF, Audio: OFF, MODEM:OFF		0.1	0.3	mA
	IDD1	Mode 1 OSC:ON , Audio: OFF, MODEM:OFF		0.9	1.7	
	IDD2	Mode 2 OSC:ON , Audio: ON , MODEM:OFF		5.5	7.6	
	IDD3	Mode 3 OSC:ON , Audio: OFF, MODEM:ON		2.2	3.4	
	IDD4	Mode 4 OSC:ON , Audio: ON , MODEM:ON		6.1	8.4	

11. Analog characteristics

For the following conditions unless otherwise specified: f=1kHz, Emphasis: on, COMPANDOR: on, Scrambler: off, VR1=VR2=VR3=VR4=0dB with the external circuit shown in example page.26 to 29. "dBx" is standardized unit for 1.9V to 5.5V operation, 0dBx=-5+20log(VDD/2)dBm, 0dBm=0.775Vrms.

1) TX Audio System

Parameter	Condition	Min.	Typ.	Max.	Units	Notes
Standard Input Level	@TXINO		-10		dBx	
Absolute Gain	TXINO to MOD	-1.5	0	+1.5	dB	
Limit Level	EXTLIMIN to MOD	-8.6	-7.6	-6.6	dBx	
	Without external R adjustment			-6.6		
Compressor Linearity	TXINO to MOD	-20.0	-17.0	-14.0	dB	
	TXINO=-44dBx TXINO=-50dBx Relative value to 0dB for MOD level of -10dBx TXINO.	-24.0	-20.0	-16.0		
Compressor Distortion	TXINO to MOD TXINO=-10dBx 30kHz Low-pass filtering			-35	dB	
Noise Level with no signal input	TXINO to MOD C-Message filtering			-36.5	dBm	
VR1 Attenuation Error	TXINO to MOD -6.0 dB to 4.5dB, 1.5dB/step	-1.5		+1.5	dB	
VR2 ATT Error (VR24,23,22,21,20)	TXINO to MOD -3.2dB to +3.0dB, 0.2dB/step	-0.2		+0.2	dB	
VR2 ATT Error (VR25=0)	TXINO to MOD Relative error for -6/0dB	-6.4	-6	-5.6	dB	

2) RX Audio System

Parameter	Condition	Min.	Typ.	Max.	Units	Notes
Standard Input Level	@RXINO		-10		dBx	
Absolute Gain	RXINO to RXLPFO	-1.5	0	+1.5	dB	
	RXINO to RXAF	-1.5	0	+1.5	dB	
Expander Linearity	RXINO to RXAF	-33.0 -45.0	-30.0 -40.0	-27.0	dB	
	RXINO=-25dBx RXINO=-30dBx Relative value to 0dB for RXAF level of -10dBx RXINO			-35.0		
Expander Distortion	RXINO to RXAF RXINO=-5dBx 30kHz Low-pass filtering			-35	dB	
Noise Level with no signal input	RXINO to RXAF C-Message Filtering			-70	dBm	
VR3 Attenuation Error	RXINO to RXAF -4.0dB to +3.5dB, 0.5dB/step	-0.5		+0.5	dB	
VR4 Attenuation Error	RXINO to RXAF -4.5 to +4.5dB, 1.5dB/step	-1.5		+1.5	dB	
VR4 ATT Error (VR42,41,40=0,0,0)	RXINO to RXAF Relative error for -18/0dB	-20	-18	-16	dB	

- Audio path frequency response (Emphasis:off)

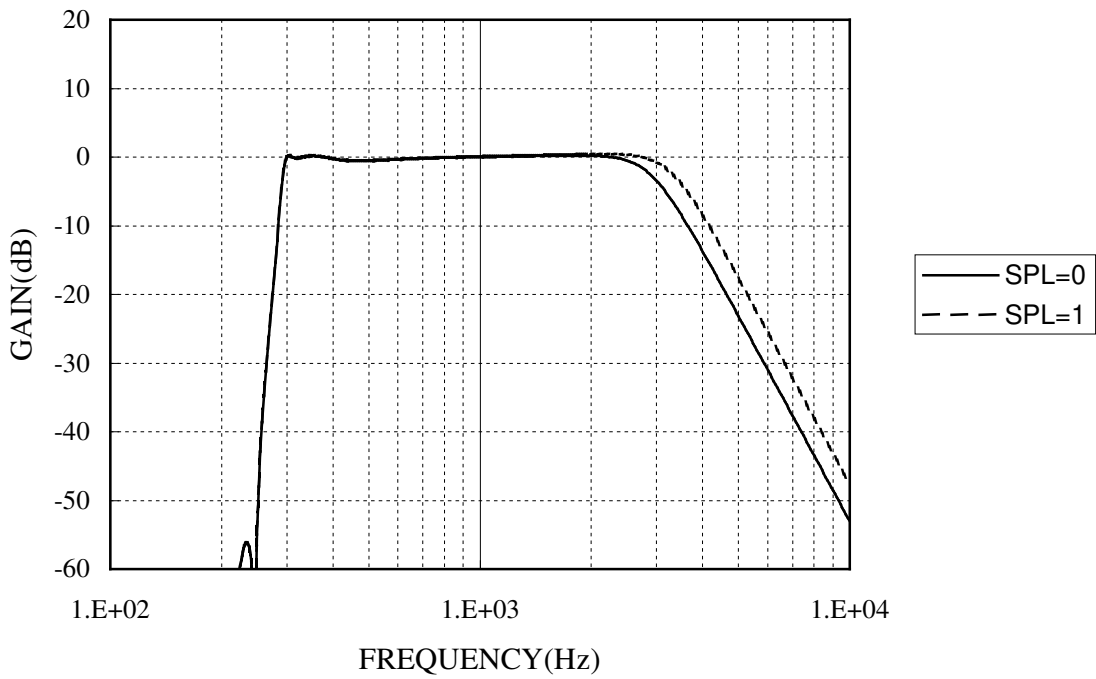

Figure 1: TX overall response without pre-emphasis.

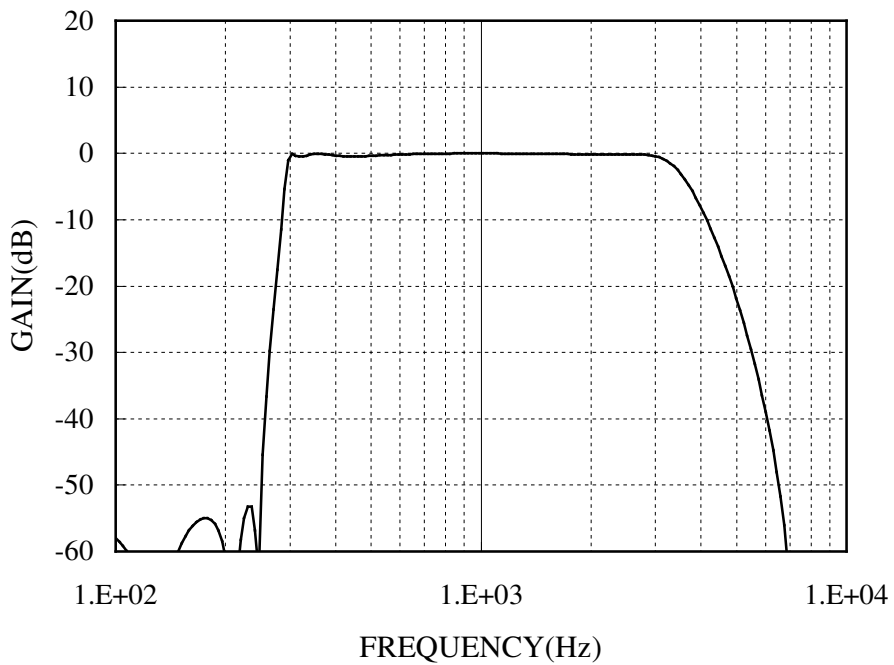

Figure 2: RX overall response without de-emphasis.

- Audio path frequency response (Emphasis:on)

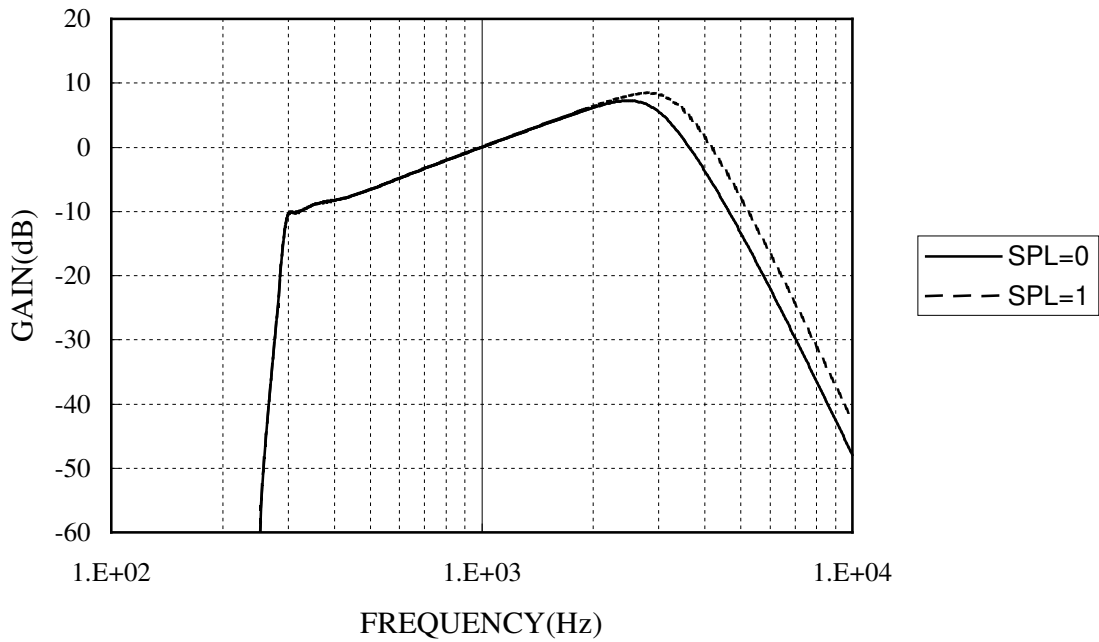

Figure 3: TX overall response with pre-emphasis.

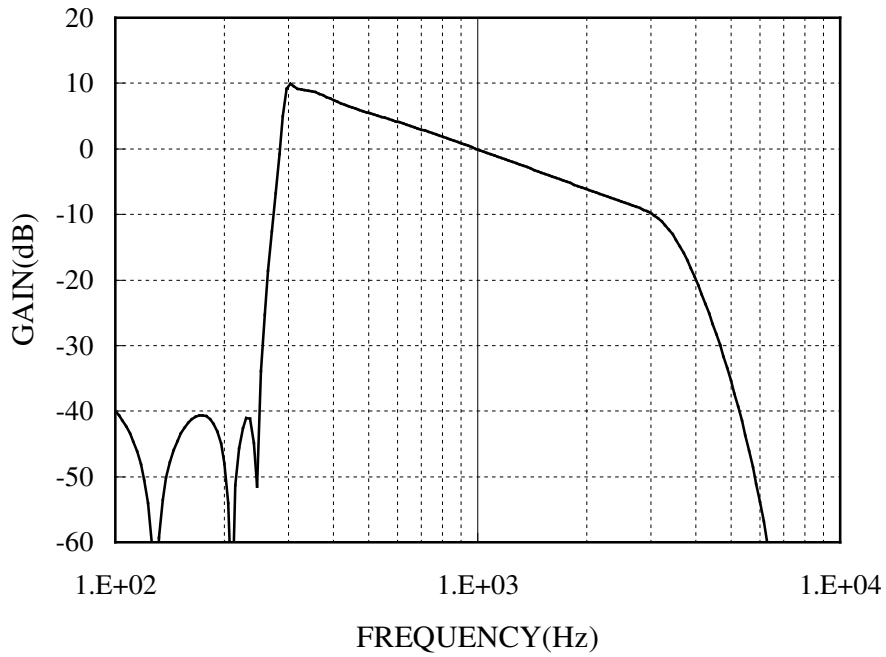

Figure 4: RX overall response with de-emphasis.

4) Scrambler Characteristics (Scrambler: **on**, Emphasis: off, COMPANDOR: off)

Parameter	Condition	Min.	Typ.	Max.	Units	Notes
Carrier Frequency			3.388		kHz	
Modulated Output Level	TXINO to MOD, RXINO to RXAF Input level 1.0kHz -10dBx Measuring-freq. 2.388kHz	-12	-10	-8	dBx	
High Frequency Rejection Level	TXINO to MOD, RXINO to RXAF Input level 1.0kHz -10dBx Measuring-freq. 4.388kHz			-50	dBx	
Carrier Signal Leakage Level	TXINO to MOD, RXINO to RXAF Input level No signal Measuring-freq. 3.388kHz			-50	dBx	
Original Signal Leakage Level	TXINO to MOD, RXINO to RXAF Input level 1.0kHz -10dBx Measuring-freq. 1.0kHz			-50	dBx	

5) MSK MODEM Characteristics

Parameter	Condition	Min.	Typ.	Max.	Units	Notes
TX Signal Level	@MOD 1.2kHz signal out	-12	-11	-10	dBx	
TX Signal Distortion	@MOD 1.2kHz signal out			-32	dB	
RX Signal Level	@RXINO 1.2kHz signal out	-17	-11	-1	dBx	

12. Level Diagram

1) TX audio system : $TXRX=0$

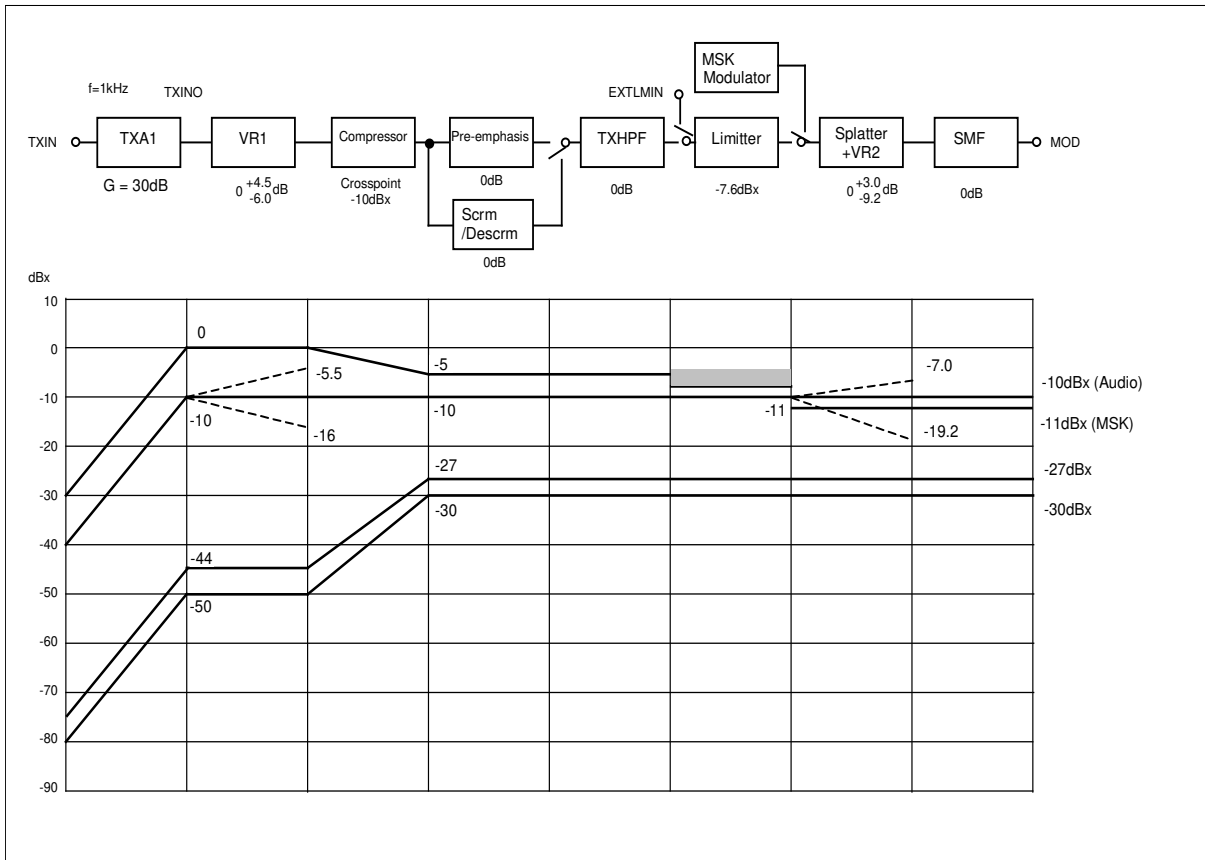

2) RX audio system : $TXRX=1$

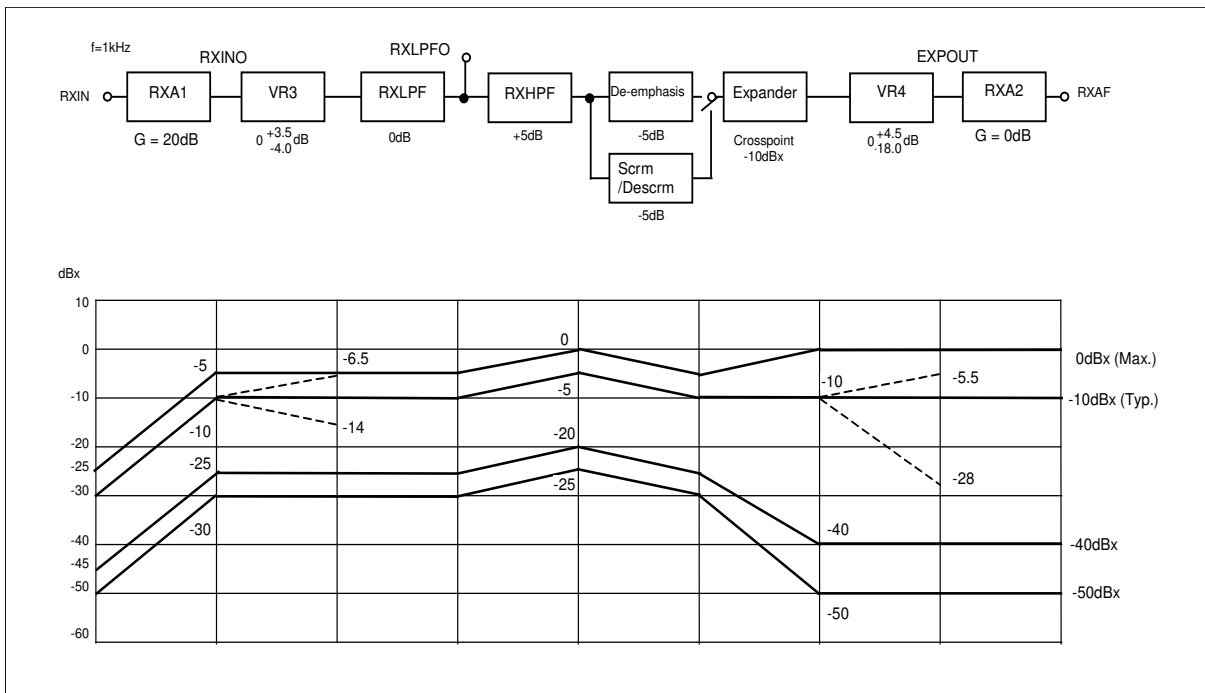

“dBx” is standardized unit for 1.9V to 5.5V operation, $0dBx = -5 + 20\log(VDD/2)dBm$, $0dBm = 0.775Vrms$.

13. Serial Interface Configuration

1) Register Configuration

Address			Function	Data							
A2	A1	A0		D7	D6	D5	D4	D3	D2	D1	D0
0	0	0	Control register 1	BS3	BS2	BS1	TXRX	TXSW2	TXSW1	RXSW	FSL
0	0	1	Control register 2	-	-	TC	EM	PCONT	SPL	MSKSL	FCLN
0	1	0	Volume register 1	-	-	-	-	-	VR12	VR11	VR10
0	1	1	Volume register 2	-	-	VR25	VR24	VR23	VR22	VR21	VR20
1	0	0	Volume register 3	-	VR33	VR32	VR31	VR30	VR42	VR41	VR40
1	0	1	MODEM register 1	Lower 8 bit of MODEM Flame pattern							
1	1	0	MODEM register 2	Upper 8 bit of MODEM Flame pattern							
1	1	1	Test register	TST7	TST6	TST5	TST4	TST3	TST2	TST1	TST0
-	-	-	MODEM register 3	MODEM Receive data							

2) Register Map

2.1) Control Register 1

Address			Data							
A2	A1	A0	D7	D6	D5	D4	D3	D2	D1	D0
0	0	0	BS3	BS2	BS1	TXRX	TXSW2	TXSW1	RXSW	FSL
Reset			0	0	0	1	1	1	1	1

2.1.1) Operation mode setting

BS3	BS2	BS1	Mode	OSC, AGND	TX, RX, Audio	MODEM
0	0	0	Mode0	OFF	OFF	OFF
0	0	1	Mode1	ON	OFF	OFF
0	1	0	Mode2	ON	ON	OFF
0	1	1	Mode3	ON	OFF	ON
1	0/1	0/1	Mode4	ON	ON	ON

2.1.2) TX, RX Setting

Data	Function	Operation		Notes
		0	1	
TXRX	TX, RX Switch	TX Operation Note 1	RX Operation Note 2	Note 3
RXSW	RX Audio	Mute	Active	Note 4
FSL	RDF/FD Switch	FD enable	RDF enable	

2.1.3) TX audio path setting

TXSW2	TXSW1	Operation		Notes
0	0	External Tone Operation (EXTLIMIN --- Limiter --- Splatter)		
0	1	MODEM Operation (MSK Modulator --- Splatter)		
1	0	Audio Operation (HPF --- Limiter --- Splatter)		
1	1	Mute (AGND --- Limiter --- Splatter)		

Note 1: TXIN to EXPOUT path is available by setting TXRX=0 and RXSW=1 in register.

However, Scrambler/Descrambler circuit does not work properly on this setting, so please set PCONT=1 (disable). To set RXSW=0 makes EXPOUT pin mute in operation.

Note 2: RXIN to MOD path is available by setting TXRX=1 and TXSW2/TXSW1=1/0 in register.

However, Scrambler/Descrambler circuit does not work properly on this setting, so please set PCONT=1 (disable). To set TXSW2/TXSW1=1/1 makes MOD pin mute in operation.

Note 3: Please set a gain level properly in each circuit block according to level diagram in page 14.

Note 4: RXLPFO pin does not be controlled by setting RXSW=0. It is normally active in RX mode.

2.2) Control Register 2

Address			Data							
A2	A1	A0	D7	D6	D5	D4	D3	D2	D1	D0
0	0	1	-	-	TC	EM	PCONT	SPL	MSKSL	FCLN
Reset			-	-	1	1	1	1	0	0

Data	Function	Operation		Notes
		0	1	
TC	COMPANDOR	OFF (disable)	ON (enable)	
SPL	Splatter cut-off frequency	2.55kHz	3.0kHz	
MSKSL	MODEM data rate	2400bps	1200bps	
FCLN	MODEM flame detect	ON (enable)	OFF (disable)	

EM	PCONT	Operation		Notes
1	1	Emphasis : ON (enable)	Scrambler : OFF(disable)	
0	1	Emphasis : OFF(disable)	Scrambler : OFF(disable)	
0/1	0	Emphasis : OFF(disable)	Scrambler : ON (enable)	

2.3) Volume Register 1

Address			Data							
A2	A1	A0	D7	D6	D5	D4	D3	D2	D1	D0
0	1	0	-	-	-	-	-	VR12	VR11	VR10
Reset			-	-	-	-	-	1	0	0

VR12	VR11	VR10	VR1 Gain (dB)
0	0	0	-6.0
0	0	1	-4.5
0	1	0	-3.0
0	1	1	-1.5
1	0	0	0.0
1	0	1	+1.5
1	1	0	+3.0
1	1	1	+4.5

2.4) Volume Register 2

Address			Data							
A2	A1	A0	D7	D6	D5	D4	D3	D2	D1	D0
0	1	1	-	-	VR25	VR24	VR23	VR22	VR21	VR20
Reset			-	-	1	1	0	0	0	0

VR25	VR2 Gain (dB)
0	-6.0
1	0.0

VR24	VR23	VR22	VR21	VR20	VR2 Gain (dB)
0	0	0	0	0	-3.2
0	0	0	0	1	-3.0
0	0	0	1	0	-2.8
0	0	0	1	1	-2.6
0	0	1	0	0	-2.4
0	0	1	0	1	-2.2
0	0	1	1	0	-2.0
0	0	1	1	1	-1.8
0	1	0	0	0	-1.6
0	1	0	0	1	-1.4
0	1	0	1	0	-1.2
0	1	0	1	1	-1.0
0	1	1	0	0	-0.8
0	1	1	0	1	-0.6
0	1	1	1	0	-0.4
0	1	1	1	1	-0.2
1	0	0	0	0	0.0
1	0	0	0	1	+0.2
1	0	0	1	0	+0.4
1	0	0	1	1	+0.6
1	0	1	0	0	+0.8
1	0	1	0	1	+1.0
1	0	1	1	0	+1.2
1	0	1	1	1	+1.4
1	1	0	0	0	+1.6
1	1	0	0	1	+1.8
1	1	0	1	0	+2.0
1	1	0	1	1	+2.2
1	1	1	0	0	+2.4
1	1	1	0	1	+2.6
1	1	1	1	0	+2.8
1	1	1	1	1	+3.0

2.5) Volume Register 3

Address			Data							
A2	A1	A0	D7	D6	D5	D4	D3	D2	D1	D0
1	0	0	-	VR33	VR32	VR31	VR30	VR42	VR41	VR40
Reset			-	1	0	0	0	1	0	0

VR33	VR32	VR31	VR30	VR3 Gain (dB)
0	0	0	0	-4.0
0	0	0	1	-3.5
0	0	1	0	-3.0
0	0	1	1	-2.5
0	1	0	0	-2.0
0	1	0	1	-1.5
0	1	1	0	-1.0
0	1	1	1	-0.5
1	0	0	0	0.0
1	0	0	1	+0.5
1	0	1	0	+1.0
1	0	1	1	+1.5
1	1	0	0	+2.0
1	1	0	1	+2.5
1	1	1	0	+3.0
1	1	1	1	+3.5

VR42	VR41	VR40	VR4 Gain (dB)
0	0	0	-18.0
0	0	1	-4.5
0	1	0	-3.0
0	1	1	-1.5
1	0	0	0.0
1	0	1	+1.5
1	1	0	+3.0
1	1	1	+4.5

2.6) MODEM Register 1,2 (Reset : Low Power Radio)

Address			Data							
A2	A1	A0	D7	D6	D5	D4	D3	D2	D1	D0
1	0	1	F07	F06	F05	F04	F03	F02	F01	F00
Reset			1	0	1	0	1	0	0	0
1	1	0	F15	F14	F13	F12	F11	F10	F09	F08
Reset			0	0	0	1	1	0	1	1

2.7) Test Register

Address			Data							
A2	A1	A0	D7	D6	D5	D4	D3	D2	D1	D0
1	1	1	TST7	TST6	TST5	TST4	TST3	TST2	TST1	TST0
Reset			1	1	1	1	1	1	1	1

Data	Function	Operation		Notes
		0	1	
TST7..0	Test Mode	Test mode	Normal mode	

2.8) MODEM Register 3

Address			Data							
A2	A1	A0	D7	D6	D5	D4	D3	D2	D1	D0
-	-	-	RD7	RD6	RD5	RD4	RD3	RD2	RD1	RD0

Data	Function	MODEM Receive data		Notes
		0	1	
RD7...0	MSKSL="0"	2.4kHz	1.2kHz	RD7 is the first received data.
	MSKSL="1"	1.8kHz	1.2kHz	

14. Digital AC timing

1) Serial Interface Timing

Parameter	Symbol	Min.	Typ.	Max.	Units
Master clock frequency	fclk		3.6864		MHz
Clock pulse width 1	ta	500			ns
Clock pulse width 2	tb	500			ns
DI/O Set up time	tc	100			ns
DI/O Hold time	td	100			ns
DIR Set up time	te	100			ns
DIR Hold time	tf	100			ns
DIR Falling to SCLK Falling time	tg	100			ns
SCLK Input rising time	th			250	ns
SCLK Input falling time	ti			250	ns

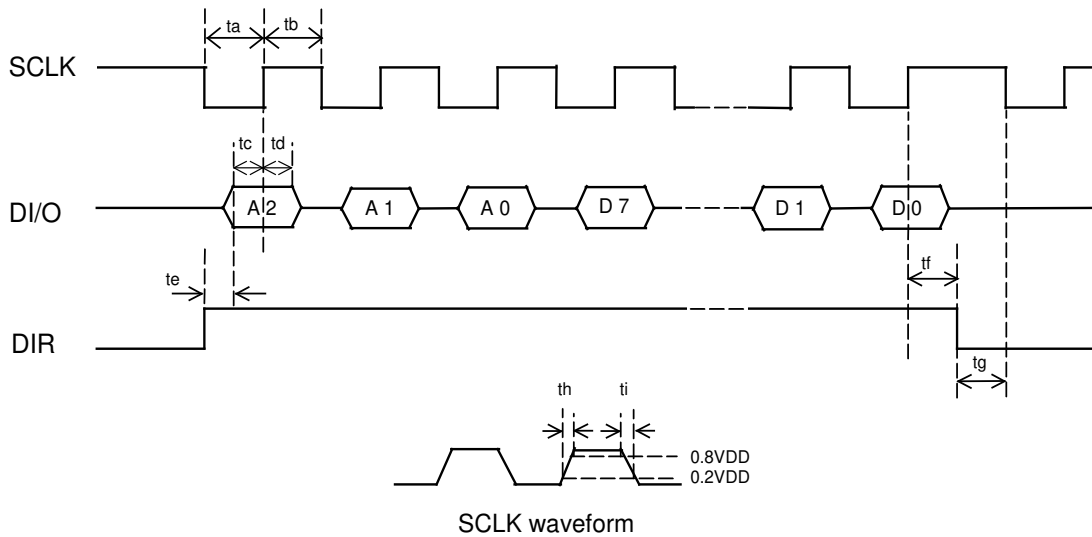

2) MSK Modulator Timing

Parameter	Symbol	Min.	Typ.	Max.	Units
TXSW2 Falling to TCLK Rising MSKSL="0" MSKSL="1"	T1		208.3 416.7		us
TCLK Period MSKSL="0" MSKSL="1"	T2		416.7 833.3		us
TXSW2 Rising to TXSW1 Falling	T3	2			ms
TDATA Set up time	TS	1			us
TDATA Hold time	TH	1			
TDATA Hold time2	TH2	2			

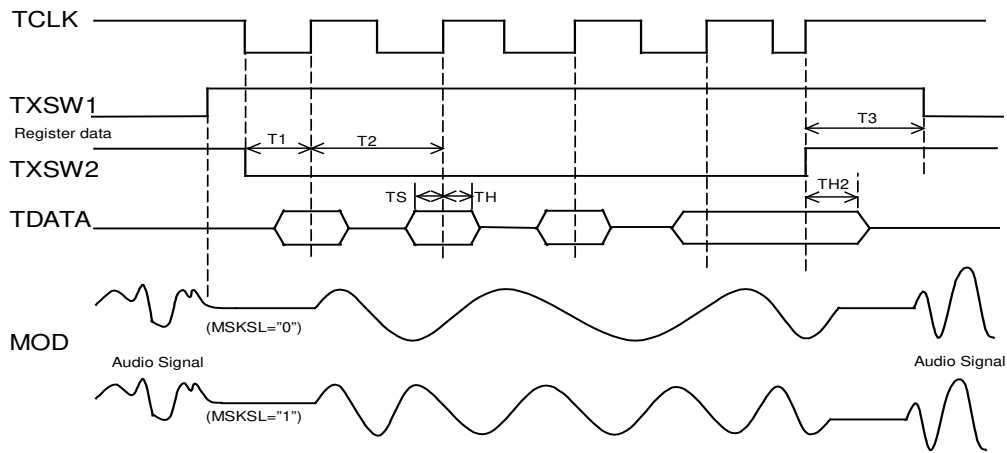

Note: The timing of setting the internal registers TXSW1 and TXSW2 is synchronized with the falling edge of DIR pin.

3) MSK Demodulator Timing

Parameter	Symbol	Min.	Typ.	Max.	Units
RCLK Period and FD pulse width MSKSL="0" MSKSL="1"	T		416.7 833.3		us
RDF Falling to SCLK Falling time	tj	100			ns
SCLK Rising to RDF Falling time	tk	600			

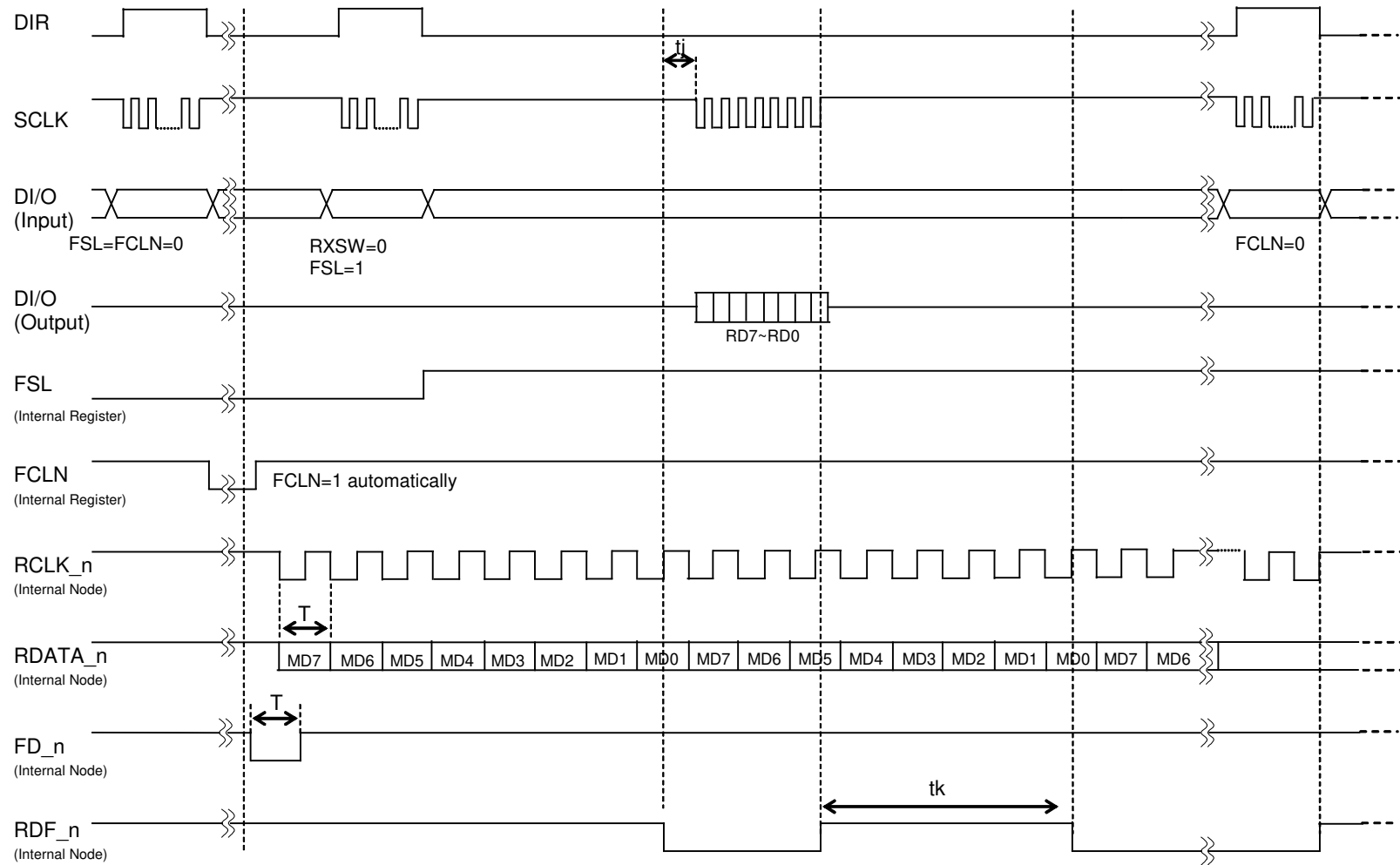

15. MSK MODEM Description

- 1) MSK Modulator control flow
 MSK data transmitter, Modulator interfaces with TCLK, TDATA and MOD pins and also TXRX, TXSW2 and TXSW1 register as below.

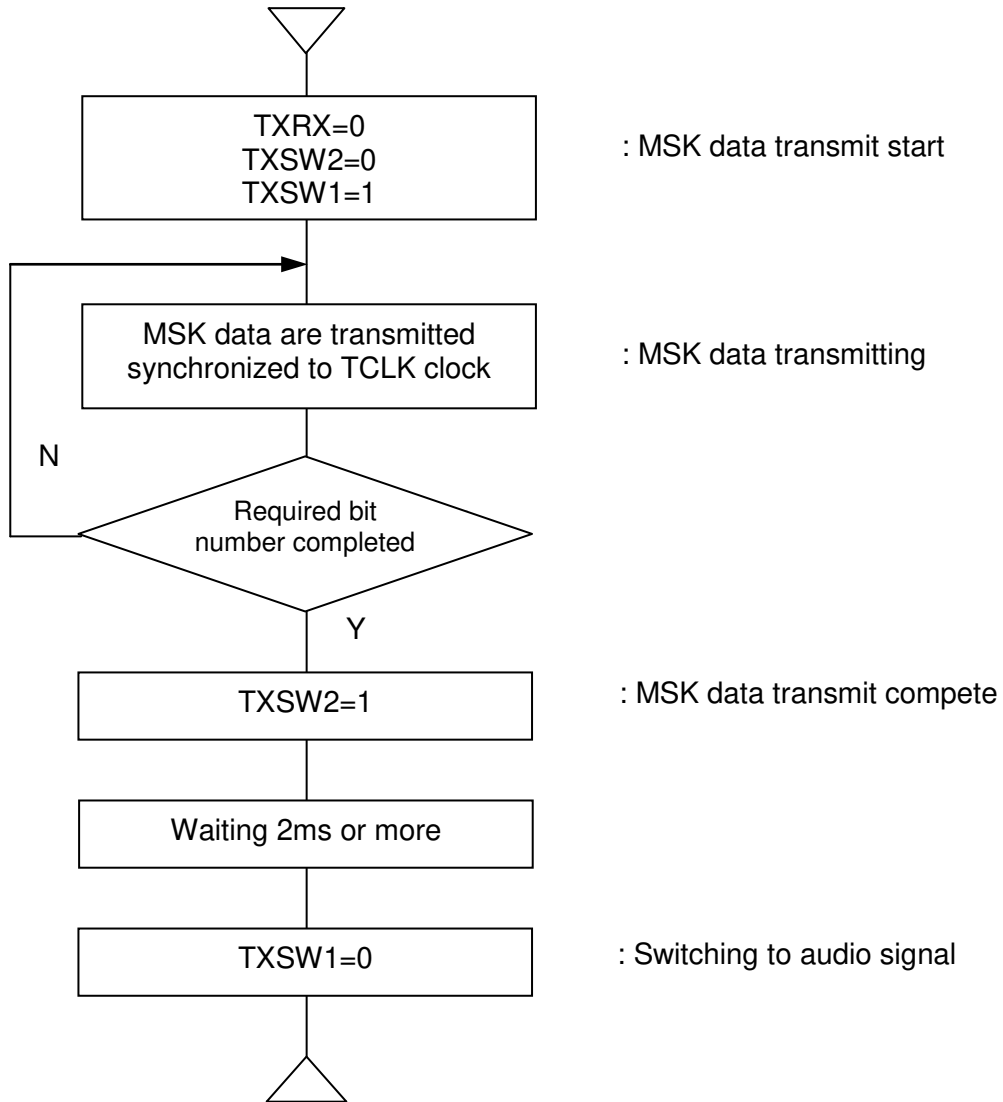

- (1) Setting TXRX=0, TXSW2=0 and TXSW1=1, MSK data transmit is provided.
- (2) A 1200/2400Hz clock is put out from TCLK pin. Synchronizing with the rising edge of TCLK, AK2346B reads the MSK transmit data from TDATA pin and puts out them to MOD pin.
- (3) After transmitting the necessary bit number, please set TXSW2=1
- (4) Afterwards, before switching to audio signal mode, please wait for at least 2ms after setting TXSW2=1 to complete sending the MSK data final data bit transmit. Then set TXSW1=1.

2) MSK Demodulator control flow

MSK data receiver, Demodulator interfaces with RXIN, RDF/FD, SCLK, DI/O and DIR pins and also FCLN, FSL, and RXSW registers as below.

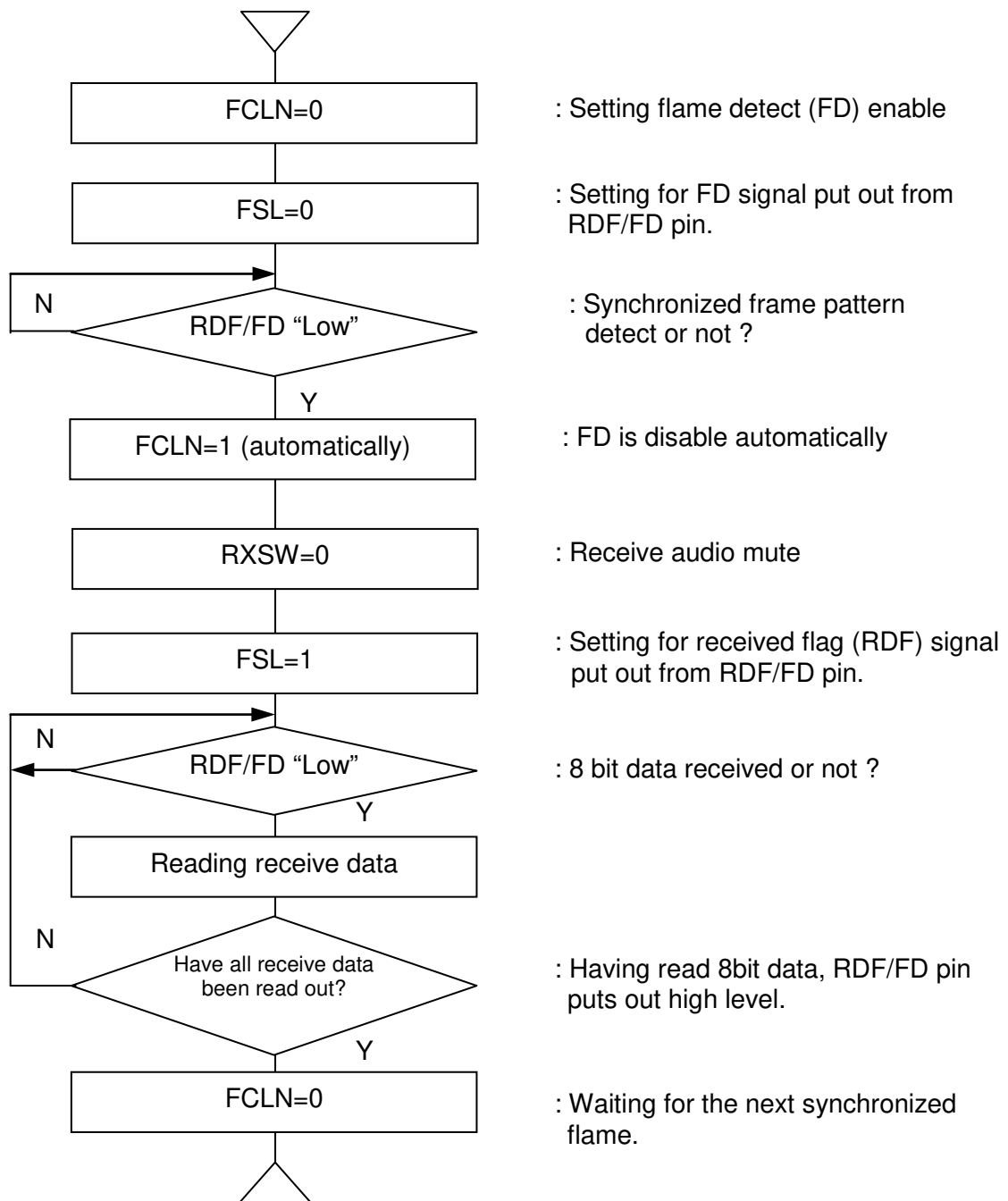

- (1) Setting FCLN=0 and FSL=0 for flame detect mode and also SCLK pin sets high level and DIR pin sets low level, RDF/FD pin puts out high level and wait for synchronized frame.
- (2) After a synchronized frame is detected, RDF/FD pin works as frame detect (FD) mode. FD goes to low level during the period of time "T", then FCLN is sets to "1" automatically.
- (3) Monitoring low level of RDF/FD pin, set RXSW=0 for audio signal mute. Then set FSL=1 for received flag (RDF), signal put out from RDF/FD pin.

- (4) After 8 bit received data (MD7...0) have been entered to the internal buffer from node RDATA, RDF/FD pin goes to low level as RDF mode.
- (5) After CPU detects this low level at RDF/FD pin, please puts in 8 clock to SCLK pin. Then modulated data (RD7...0) put out from DI/O pin synchronized with falling edge of SCLK clock.
- (6) After 8 clock have been put into SCLK pin completely, RDF/FD pin goes to high level that shows all modulated data coming from DI/O pin.
- (7) By repeating the steps (4), (5), (6), the data come out from DI/O pin continuously.
- (8) After the necessary data have been read, DIR pin sets to high level and FCLN=0. Then internal node RCLK and RDATA are set to "1" for initializing and system waits for the next synchronization frame data.

This frame detection circuit does not have reset function. In case of stopping the sequence during the steps (1) to (8), please set again from the first step (1). Especially, when RDF/FD pin goes out low level on frame detecting, FCLN register is sets to "1" automatically as written in (2). If you set FCLN=0 during this operation, the date set "0" is ignored. So please set the data again after RDF/FD pin puts out high level.

When frame detection is not used, please set FCLN=1 and FSL=1 from the beginning. In that case, monitoring the low level put out from RDF/FD pin, then puts 8 clock into the SCLK pin as written in step (4). In this sequence, please program the frame detecting operation by microprocessor.