

Chipsmall Limited consists of a professional team with an average of over 10 year of expertise in the distribution of electronic components. Based in Hongkong, we have already established firm and mutual-benefit business relationships with customers from,Europe,America and south Asia,supplying obsolete and hard-to-find components to meet their specific needs.

With the principle of “Quality Parts,Customers Priority,Honest Operation,and Considerate Service”,our business mainly focus on the distribution of electronic components. Line cards we deal with include Microchip,ALPS,ROHM,Xilinx,Pulse,ON,Everlight and Freescale. Main products comprise IC,Modules,Potentiometer,IC Socket,Relay,Connector.Our parts cover such applications as commercial,industrial, and automotives areas.

We are looking forward to setting up business relationship with you and hope to provide you with the best service and solution. Let us make a better world for our industry!



Contact us

Tel: +86-755-8981 8866 Fax: +86-755-8427 6832

Email & Skype: info@chipsmall.com Web: www.chipsmall.com

Address: A1208, Overseas Decoration Building, #122 Zhenhua RD., Futian, Shenzhen, China



AK2347B

Two-way Radio Audio & Sub-Audio Processor

1. Features

- Audio processing
 - TX and RX amplifier
 - Pre/De-emphasis circuit
 - Compressor and Expander with no external components
 - Scrambler and De-scrambler in frequency inversion type (3.388kHz or 3.290kHz)
 - Limiter with level adjuster
 - Splatter filter for wide and narrow band
 - Digital controlled amplifier for microphone, modulator and demodulator sensitivity
- Sub-Audio filter with level adjuster for CTCSS and DCS
- Low power supply operation: 2.7 to 3.3V
- Wide range operating for temperature: -40 to 85 °C
- Oscillator circuit for 3.6864MHz and 3.579545MHz crystal
- Serial control interface operation
- Compact plastic packaging, 24-pin SSOP

2. Description

AK2347B includes audio filter, limiter, splatter filter, compandor, scrambler, which is highly integrated two-way radio baseband functions for FRS and LMR.

Audio high-pass filter shows a high attenuation in magnitude response characteristics under 250Hz that supports to eliminate a subaudio tone clearly.

TX limiter for deviation control has a limiting level adjuster by applying a DC voltage via external components. Splatter filter has the magnitude response for narrowband($f_c=2.55\text{kHz}$) and wideband(3.0kHz) to meet various regulatory agencies in the world wide.

Compandor is no adjustment type because it includes all parametric components inside the chip. Scrambler circuit is composed of frequency inversion circuit by double balanced mixer that has 3.388kHz and 3.290kHz carrier clock.

Sub-Audio filter with level adjuster is available for pre- or post-filter for CTCSS and DCS.

There are four signal level adjusters for microphone, modulator and demodulator sensitivity by digital controlled amplifier (volume).

- Pin Assignment (Top view)

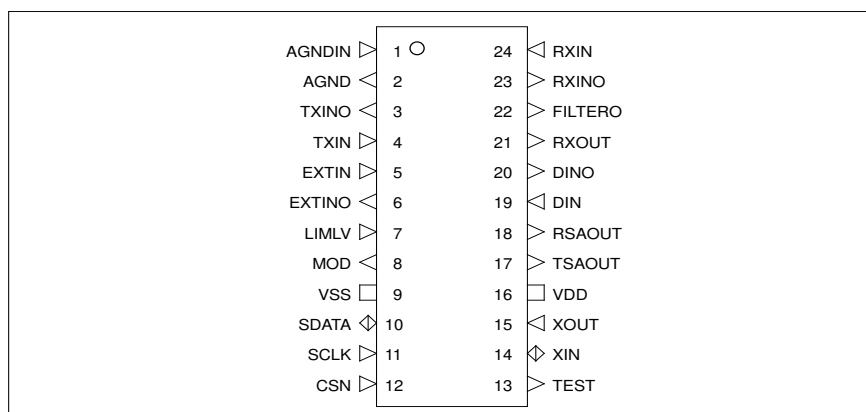

3. Contents

1. Features	1
2. Description	1
3. Contents	2
4. Block Diagram	3
5. Block Functions	4
6. Pin Functions	5
7. Absolute Maximum Ratings	7
8. Recommended Operating Conditions	7
9. Digital DC Characteristics	7
10. Clock Input Characteristics	8
11. Current Consumption	8
12. Analog Characteristics	9
13. Level Diagram	15
14. Digital AC Timing	16
15. Register Function Description	18
16. Recommended External Application Circuits	28
17. Packaging	33
18. Important Notice	34

4. Block Diagram

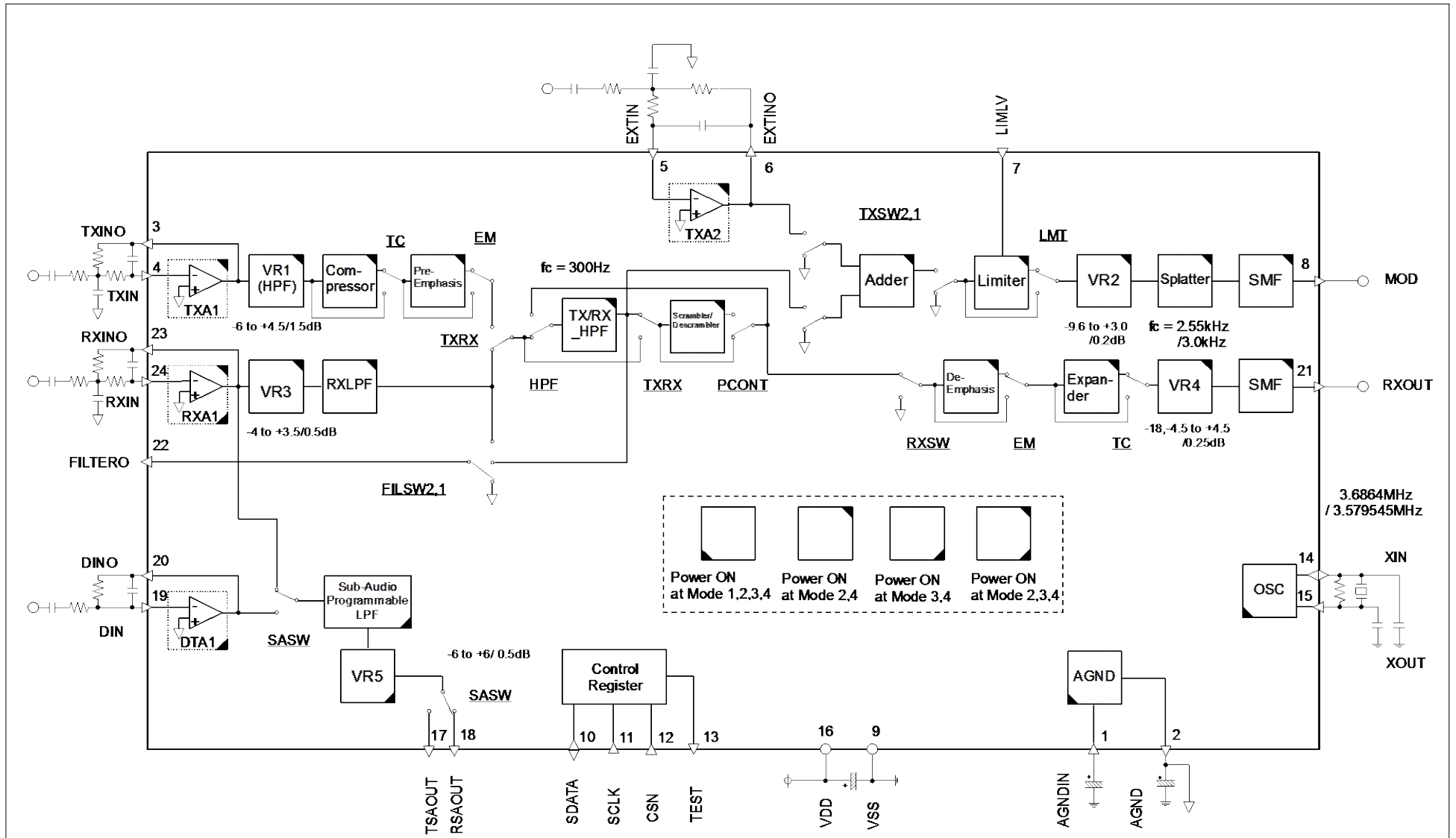

5. Block Functions

Block	Function
TXA1	Operational amplifier for gain adjustment of transmit audio signal and for the filter for preventing aliasing noise of the SCF circuit in the subsequent stage. Use external resistors and capacitors to set the gain to 30dB or less and the cut-off frequency to around 10kHz.
VR1 (HPF)	This circuit controls the volume for adjusting the input level of transmit audio signal. Setting registers: VR12 to VR10, adjustment range: -6.0dB to +4.5dB in 1.5dB steps
Compressor	This circuit compresses the amplitude of transmit audio signal by 1/2 in dB scale. Cross-point: -10dBx. This circuit is turned on and off by the TC register.
Pre-emphasis	This circuit emphasizes the high-frequency component of transmit audio signal to improve the S/N ratio of the modulation signal.
TX/RX_HP	High-pass filter to eliminate low-frequency components lower than 250Hz which are included in transmit and receive audio signals. This circuit is turned on and off by the HPF register.
Scrambler/Descrambler	This circuit inverts the spectrum distribution of transmit and receive audio signals with respect to the carrier frequency. The carrier frequency is 3.388kHz or 3.290kHz. The Scrambler/Descrambler or emphasis circuit can be selected using the EM and PCONT registers. These circuits cannot be used at the same time.
TXA2	Operational amplifier for gain adjustment of external tone signal. Use external resistors and capacitors to set the gain to 0dB or less and the cut-off frequency to around 10kHz.
Adder	This circuit adds together the audio signal and external tone input signal. This circuit is controlled by the TXSW2 and TXSW1 register.
Limiter	Amplitude limiting circuit to suppress frequency deviation in the modulation signal. The limit level can be adjusted by applying a DC voltage to the LIMLV pin. When the pin is left open, the level predetermined within the device is output. This circuit is turned on and off by the LMT register.
VR2	This circuit controls the volume for adjusting the output level on the MOD pin. Setting registers: VR25 to VR20, adjustment range: -3.2dB to +3.0dB in 0.2dB steps. For coarse adjustment, switching between -6.4dB and 0dB is possible.
Splatter	Low-pass filter to eliminate high-frequency components higher than 3kHz which are included in the limiter output signal. The cut-off frequency can be adjusted with the SPL register.
SMF	Smoothing filter to eliminate the high-frequency and clock components generated in the SCF circuit.
RXA1	Operational amplifier for gain adjustment of the receive demodulation signal and for the filter for preventing aliasing noise in the SCF circuit in the subsequent stage. Use external resistors and capacitors to set the gain to 20dB or less and the cut-off frequency to around 40kHz.
VR3	This circuit controls the volume for adjusting the input level of the receive demodulation signal. Setting registers: VR33 to VR30, adjustment range: -4.0dB to +3.5dB in 0.5dB steps
RXLPF	Low-pass filter to eliminate high-frequency components higher than 3kHz which are included in the receive demodulation signal.
De-emphasis	This circuit restores the original state of the signal of which high-frequency component has been emphasized by the Pre-emphasis.
Expander	This circuit expands the signal compressed twice by the Compressor in dB scale to restore the original signal state. Cross-point: -10dBx. The Expander is turned on and off with the TC register.
VR4	This circuit controls the volume for adjusting the RX output level. Setting registers: VR45 to VR40 Adjustment range: -18.0dB, -4.5dB to +4.5dB in 0.25dB steps

Block	Function
DTA1	Operational amplifier for gain adjustment of the Sub-Audio LPF input signal and for the filter for preventing aliasing noise in the SCF circuit in the subsequent stage. Use external resistors and capacitors to set the gain to 0dB or less and the cut-off frequency to around 10kHz.
Sub-Audio Programmable LPF	Low-pass filter to eliminate components of the DAT1 signal in the transmit operation and of RXA1 signal in the receive. This circuit is controlled by the SASW register for transmit or receive and by the SA5 to SA0 for cut-off frequency.
VR5	This circuit controls the volume for adjusting the output level from the Sub-Audio LPF signal. Setting registers: VR54 to VR50, adjustment range: -6.0dB to +6.0dB in 0.5dB steps
AGND	This circuit generates the reference voltage (1/2VDD) for internal analog signals.
OSC	This circuit generates a 3.6864MHz or 3.579545MHz reference clock signal from an external resistor and crystal oscillator. This circuit is controlled by the MCKSL register.
Control Register	Control registers set the switch status and volume for level adjustment inside the IC according to the serial input data consisting of 1-bit instruction and 4-bit address and 8-bit data. At power-up, the registers are set to the power-down values by the power-on reset circuit. This circuit has a software reset named RSTN register. (See the description of the registers)

6. Pin Functions

Pin number	Pin name	Pin type	Power-down status	Function
1	AGNDIN	AI	*3)	Analog ground input pin This pin is connected to a capacitor to stabilize the analog ground level.
2	AGND	AO	*3)	Analog ground output pin This pin is connected to a capacitor to stabilize the analog ground level.
3	TXINO	AO	Z	Output pin of TXA1 *1)
4	TXIN	AI	Z	Transmit audio signal input pin This pin is the inverting input pin of TXA1. This pin, with resistors and capacitors externally connected, forms a microphone amplifier.
5	EXTIN	AI	Z	External input pin This pin is the inverting input pin of TXA2. This pin, with resistors and capacitors externally connected, forms an amplifier. An external signal such as a tone signal other than the audio signal can be input.
6	EXTINO	AO	*3)	Output pin of TXA2 *1)
7	LIMLV	AI	*4)	Limit level adjustment pin The limit level can be adjusted by applying a DC voltage to this pin. When this pin is left open, the limit level predetermined within the device is set.
8	MOD	AO	Z	Modulated transmit signal output pin *2)
9	VSS	PWR	-	Negative power supply pin Normally, apply 0V.
10	SDATA	DB	Z	Serial data input and output control pin

Pin number	Pin name	Pin type	Power-down status	Function
11	SCLK	DI	Z	Serial data clock input pin
12	CSN	DI	Z	Serial data chip select input This signal is active low.
13	TEST	DO	L	Output pin for testing This pin is assigned to test pin for pre-delivery inspection in factory. Do not connect anything in normal operation.
14	XIN	DB	*5)	Pin for connecting a crystal oscillator A reference clock used within this IC is generated by connecting a 3.6864MHz or 3.579545MHz oscillator between this pin and the adjacent XOUT pin. For detailed information about the connection method and the method for supplying an external clock, see "Recommended External Application Circuits".
15	XOUT	DI	*5)	Pin for connecting a crystal oscillator
16	VDD	PWR	-	Positive power supply pin Connect this pin to a power supply ranging from 2.7V to 3.3V with less noise. Connect a bypass capacitor of 0.1μF or higher between this pin and the VSS pin.
17	TSAOUT	AO	Z	Transmit Sub-Audio signal output pin *2)
18	RSAOUT	AO	Z	Receive Sub-Audio signal output pin *2)
19	DIN	AI	Z	Data input pin This pin is the inverting input pin of DTA1. This pin, with resistors and capacitors externally connected, forms an amplifier. An external signal such as a tone signal through CPU port can be input.
20	DINO	AO	Z	Output pin of DTA1 *1)
21	RXOUT	AO	Z	Receive audio signal output pin *2)
22	FILTERO	AO	Z	RXLPF or TX/RX_HPFP block output pin This pin can be used as a monitor pin for a signal such as a tone signal. The output signal on this pin includes a 57.6kHz sampling-clock component. So, perform waveform processing externally as required. *2)
23	RXINO	AO	Z	Output pin of RXA1 *1)
24	RXIN	AI	Z	Demodulated receive signal input pin Inverting input pin of RXA1. This pin, with resistors and capacitors externally connected, forms a pre-filter.

Note) A: Analog, D: Digital, PWR: Power, I: Input, O: Output, B: Bi-directional, Z: High-Z, L: Low

*1) Output load requirement: [load impedance] > 30kΩ, [load capacitance] < 50pF

*2) Output load requirement: [load impedance] > 10kΩ, [load capacitance] < 50pF

*3) AGND (=1/2VDD) level

*4) AGND + 0.256(VDD-AGND) level

*5) When XOUT pin is set to low level, XIN pin goes to High-Z.
When XOUT pin is set to high level, XIN pin outputs low level.

7. Absolute Maximum Ratings

Parameter	Symbol	Min.	Max.	Units
Power Supply Voltage	VDD	-0.3	4.6	V
Ground Level	VSS	0	0	V
Input Voltage	V _{IN}	-0.3	VDD+0.3	V
Input Current (Except power supply pin)	I _{IN}	-10	+10	mA
Storage Temperature	T _{stg}	-55	130	°C

Note) All voltages are relative to the VSS pin.

Caution) If the device is used in conditions exceeding these values, the device may be destroyed. Normal operations are not guaranteed in such extreme conditions.

8. Recommended Operating Conditions

Parameter	Symbol	Condition	Min.	Typ.	Max.	Units
Operating Temperature	T _a		-40		85	°C
Power Supply Voltage	VDD		2.7	3.0	3.3	V
Analog Reference Voltage	AGND			1/2VDD		V

Note) All voltages are relative to the VSS pin.

9. Digital DC Characteristics

Parameter	Symbol	Condition	Min.	Typ.	Max.	Units
High level input voltage	V _{IH1}	SDATA	0.7VDD			V
	V _{IH2}	SCLK, CSN	0.8VDD			
Low level input voltage	V _{IL1}	SDATA			0.3VDD	V
	V _{IL2}	SCLK, CSN			0.2VDD	
High level input current	I _{IH}	V _{IH} =VDD SDATA, SCLK, CSN			10	μA
Low level input current	I _{IL}	V _{IL} =0V SDATA, SCLK, CSN	-10			μA
High level output voltage	V _{OH}	I _{OH} =+0.2mA SDATA	VDD-0.4		VDD	V
Low level output voltage	V _{OL}	I _{OL} =-0.4mA SDATA	0.0		0.4	V

10. Clock Input Characteristics

Parameter	Symbol	Condition	Min.	Typ.	Max.	Units	Remarks
Master Clock Frequency	MCK	XIN, XOUT		3.6864 3.579545		MHz	
High level input voltage	V_{MCK1_IH}	XIN	1.5			V	*1)
Low level input voltage	V_{MCK1_IL}	XIN			0.4	V	*1)
Input amplitude	V_{MCK2}	XIN	0.2		1.0	V_{PP}	*2)

*1) When directly connects to XIN pin, refer to “Recommended External Application” 7) Oscillator circuit Fig. 7.

*2) When connects to XIN pin via capacitor, refer to “Recommended External Application” 7) Oscillator circuit Fig. 8.

11. Current Consumption

Parameter	Symbol	Condition	Min.	Typ.	Max.	Units
Current Consumption	IDD0	Mode 0 OSC:OFF, Audio: OFF, Sub-Audio: OFF		0.08	0.14	mA
	IDD1	Mode 1 OSC: ON , Audio: OFF, Sub-Audio: OFF		0.7	1.0	
	IDD2	Mode 2 OSC: ON , Audio: ON , Sub-Audio: OFF		4.5	5.8	
	IDD3	Mode 3 OSC: ON , Audio: OFF, Sub-Audio: ON		1.6	2.1	
	IDD4	Mode 4 OSC: ON , Audio: ON , Sub-Audio: ON		5.3	6.7	

12. Analog Characteristics

Unless otherwise specified, the following apply: MCK=3.6864MHz, f=1kHz, Emphasis: on, Compandor: on, Scrambler: off, VR1=VR2=VR3=VR4=0dB, HPF=LMT=1 with the external circuit shown in page.28 to 32.

“dBx” is a standardized notation to match the operating voltage and is defined by equation $0dBx = -5 + 20\log(VDD/2)dBm$. $0dBm = 0.775V_{rms}$.

1) TX Audio system characteristics

Parameter	Condition	Min.	Typ.	Max.	Units	Remarks
Standard input level	@TXINO, EXTINO		-10		dBx	
Absolute gain	TXINO to MOD	-1.5	0	+1.5	dB	
	EXTIN to MOD	-1.5	0	+1.5	dB	
Distortion	EXTIN to MOD, EXTINO=-3dBx When LMT is set to 0 30kHz Low-pass filtering			-35	dB	
Limit level	EXTIN to MOD					
	Without external R adjustment With external R adjustment	-8.6	-7.6	-6.6 -6.6	dBx	
Compressor linearity	TXINO to MOD					
	TXINO=-44dBx TXINO=-50dBx Relative value to 0dB for MOD level of -10dBx TXINO.	-20.0 -24.0	-17.0 -20.0	-14.0 -16.0	dB	
Compressor distortion	TXINO to MOD TXINO=-10dBx 30kHz Low-pass filtering			-35	dB	
Noise level with no signal input	TXINO to MOD C-Message filtering			-36.5	dBm	
VR1 Attenuation error	TXINO to MOD -6.0 dB to 4.5dB, 1.5dB/step	-1.5		+1.5	dB	
VR2 ATT error (VR24,23,22,21,20)	TXINO to MOD -3.2dB to +3.0dB, 0.2dB/step	-0.2		+0.2	dB	
VR2 ATT error (VR25=0)	TXINO to MOD Relative value when -6.4/0dB is set	-6.8	-6.4	-6.0	dB	

2) RX Audio system characteristics

Parameter	Condition	Min.	Typ.	Max.	Units	Remarks
Standard Input Level	@RXINO		-10		dBx	
Absolute gain	RXINO to FILTERO	-1.5	0	+1.5	dB	
	RXINO to RXOUT	-1.5	0	+1.5	dB	
Expander linearity	RXINO to RXOUT					
	RXINO=-25dBx RXINO=-30dBx Relative value to 0dB for RXOUT level of -10dBx RXINO	-33.0 -45.0	-30.0 -40.0	-27.0 -35.0	dB	
Expander distortion	RXINO to RXOUT RXINO=-5dBx 30kHz Low-pass filtering			-35	dB	
Noise level with no signal input	RXINO to RXOUT C-Message Filtering			-70	dBm	

Parameter	Condition	Min.	Typ.	Max.	Units	Remarks
VR3 Attenuation error	RXIN0 to RXOUT -4.0dB to +3.5dB, 0.5dB/step	-0.5		+0.5	dB	
VR4 Attenuation error	RXIN0 to RXOUT -4.5 to +4.5dB, 1.5dB/step	-0.25		+0.25	dB	
VR4 ATT error (VR45...40=0,0,0,0,0,0)	RXIN0 to RXOUT Relative value when -18/0dB is set	-20	-18	-16	dB	

3) Audio Filter Characteristics

3.1) Emphasis: **on**, Compandor: off, Scrambler: off

Parameter	Condition	Min.	Typ.	Max.	Units	Remarks	
TX overall characteristics	TXINO to MOD	250Hz		-57	-40	dB	
		300Hz	-12.5		-9.5		SPL=0 fc=2.55 K
	2.5kHz	+6.0		+9.0	dB		
	3.0kHz	+4.5		+8.5			
	6.0kHz		-23	-18			
	Relative value to gain at 1kHz	300Hz	-12.5		-9.5		SPL=1 fc=3.0K
		2.5kHz	+6.0		+9.0	dB	
		3.0kHz	+7.0		+10.5		
6.0kHz			-17	-12			
RX overall characteristics	RXINO to RXAF	250Hz		-38	-26		
		300Hz	+8.5		+11.5	dB	
	Relative value to gain at 1kHz	3.0kHz	-11.5		-8.5		
		6.0kHz		-52	-40		

3.2) Emphasis: **off**, Compandor: off, Scrambler: off target values)

(Design

Parameter	Condition	Min.	Typ.	Max.	Units	Remarks	
TX overall characteristics	TXINO to MOD	250Hz		-50	-38	dB	
		300Hz to 2.0kHz	-1.0		+1.0		SPL=0 fc=2.55 K
	2.5kHz	-1.5		+1.0	dB		
	3.0kHz	-4.0		-1.0			
	6.0kHz		-32	-28			
	Relative value to gain at 1kHz	300Hz to 2.5kHz	-1.0		+1.0		SPL=1 fc=3.0K
		3.0kHz	-1.5		+1.0	dB	
		6.0kHz		-26	-22		
RX overall characteristics	RXINO to RXAF	250Hz		-49	-38		
		300Hz	-1.5		+1.0	dB	
	Relative value to gain at 1kHz	350Hz to 3.0kHz	-1.0		+1.0		
		6.0kHz		-38	-28		

- Audio path frequency response for TX

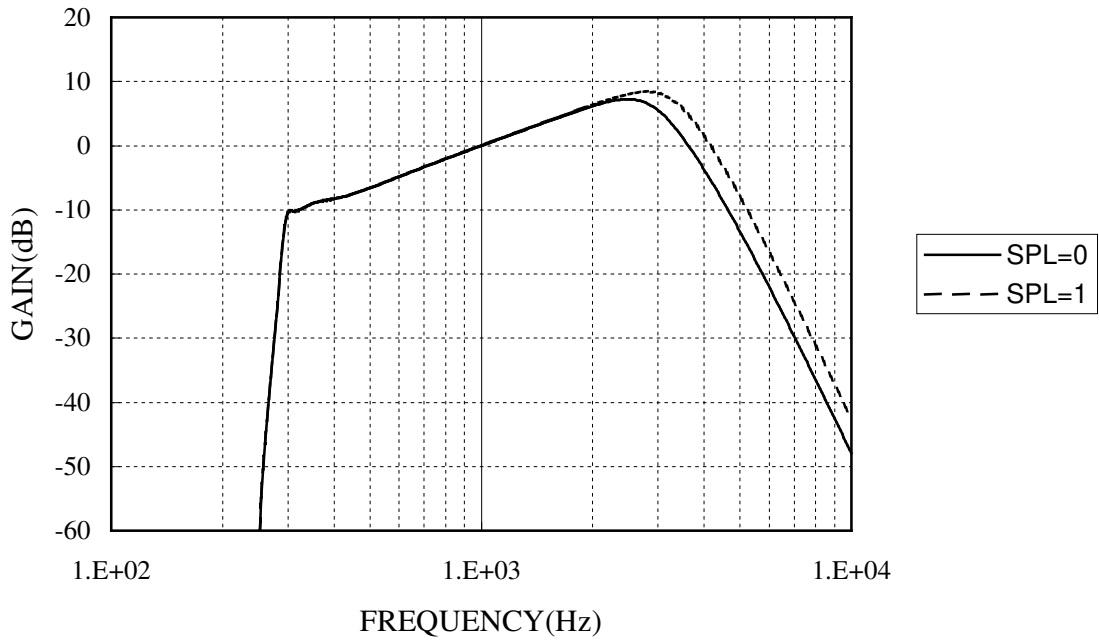

Figure 1: TX overall response with pre-emphasis.

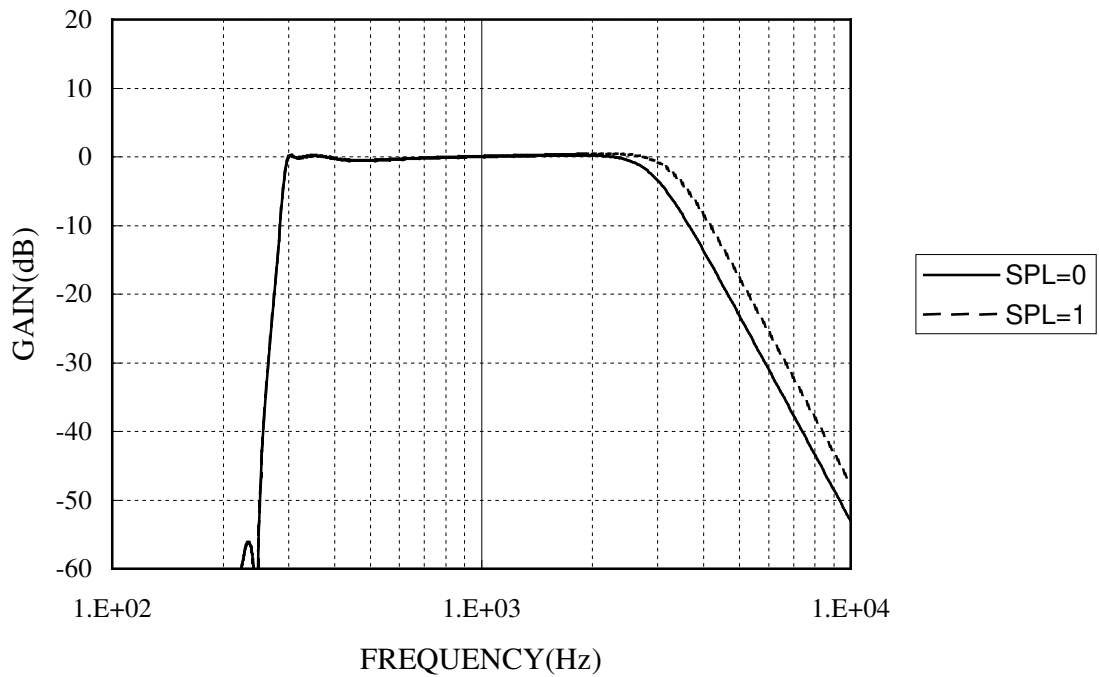

Figure 2: TX overall response without pre-emphasis.

- Audio path frequency response for RX

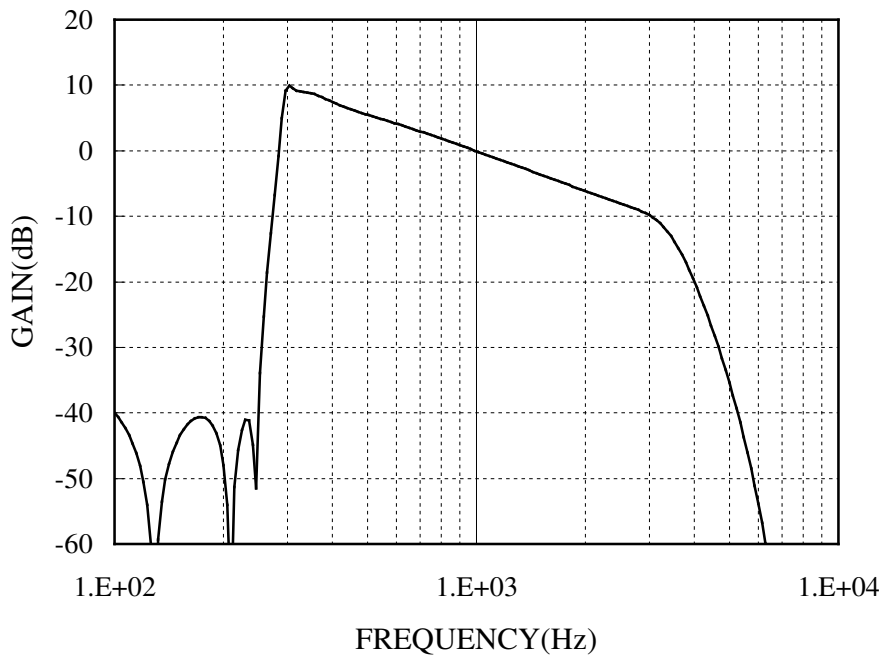

Figure 3: RX overall response with de-emphasis.

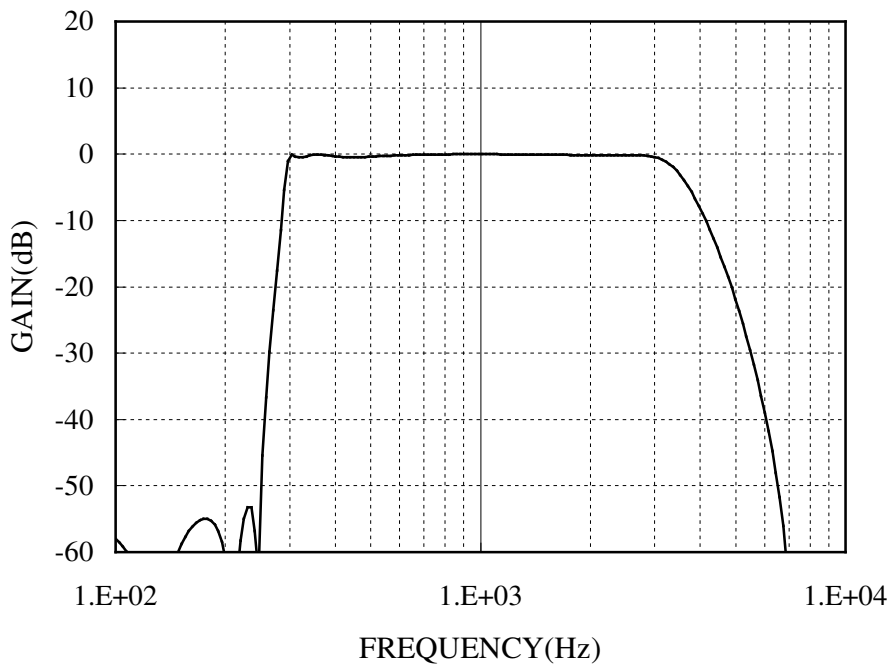

Figure 4: RX overall response without de-emphasis.

4) Scrambler Characteristics

4.1) Scrambler: **on**, Emphasis: off, Compondor: off, MCKSL=1, SCSL=0/1...3.388kHz
 MCKSL=0, SCSL=0 ...3.290kHz

Parameter	Condition	Min.	Typ.	Max.	Units	Remarks
Carrier frequency			3.388 3.290		kHz	
Modulated output	TXINO to MOD, RXINO to RXOUT Input level 1.0kHz -10dBx Measuring-freq. 2.388kHz (3.388kHz) Measuring-freq. 2.290kHz (3.290kHz)	-12	-10	-8	dBx	
High frequency rejection	TXINO to MOD, RXINO to RXOUT Input level 1.0kHz -10dBx Measuring-freq. 4.388kHz (3.388kHz) Measuring-freq. 4.290kHz (3.290kHz)			-50	dBx	
Carrier signal leakage	TXINO to MOD, RXINO to RXOUT Input level No signal Measuring-freq. 3.388kHz Measuring-freq. 3.290kHz			-50	dBx	
Original signal leakage	TXINO to MOD, RXINO to RXOUT Input level 1.0kHz -10dBx Measuring-freq. 1.0kHz			-50	dBx	

4.2) Scrambler: **on**, Emphasis: off, Compondor: off, MCKSL=0, SCSL=1 (Design target values)

Parameter	Condition	Min.	Typ.	Max.	Units	Remarks
Carrier frequency			3.390		kHz	
Modulated output	TXINO to MOD, RXINO to RXOUT Input level 1.0kHz -10dBx Measuring-freq. 2.390kHz	-12	-10	-8	dBx	
High frequency rejection	TXINO to MOD, RXINO to RXOUT Input level 1.0kHz -10dBx Measuring-freq. 4.390kHz			-50	dBx	
Carrier signal leakage	TXINO to MOD, RXINO to RXOUT Input level No signal Measuring-freq. 3.390kHz			-50	dBx	
Original signal leakage	TXINO to MOD, RXINO to RXOUT Input level 1.0kHz -10dBx Measuring-freq. 1.0kHz			-25	dBx	

5) Sub-Audio filter Characteristics

Unless otherwise specified, the following apply: MCKSL=1, SA5=1, SA4=1, SA3=0, SA2=0, SA1=0, SA0=1($f_c=260.9\text{Hz}$), VR5=0dB, 250.3Hz sinusoidal wave.

5.1) Analog characteristics

Parameter	Condition	Min.	Typ.	Max.	Units	Remarks
Standard input level	@ TSAOUT		-10		dBx	
Transmit CTCSS signal gain	DINO to TSAOUT	-2	0	+2	dB	
Transmit CTCSS signal distortion	DINO to TSAOUT 250.3Hz, Duty50%, 585mVp-p(@3V)rectangular wave 30kHz Low-pass filtering		-37	-32	dB	
Standard input level	@ RSAOUT		-10		dBx	
Receive CTCSS signal gain	RXINO to RSAOUT	-2	0	+2	dB	
Receive CTCSS signal distortion	RXINO to RSAOUT RXINO=-10dBx input 30kHz Low-pass filtering		-37	-32	dB	
VR5 Attenuation error	RXINO to RSAOUT -6.0 to +6.0dB, 0.5dB/step	-0.5		+0.5	dB	

5.2) Filter characteristics

Parameter	Condition	Min.	Typ.	Max.	Units	Remarks
Overall characteristics @ $f_c=260.9\text{Hz}$	DINO to TSAOUT	50~240Hz	-1.0	+1.0	dB	
	Relative value to	250Hz	-1.5	+1.0		
	gain at 100Hz	300Hz		-38		

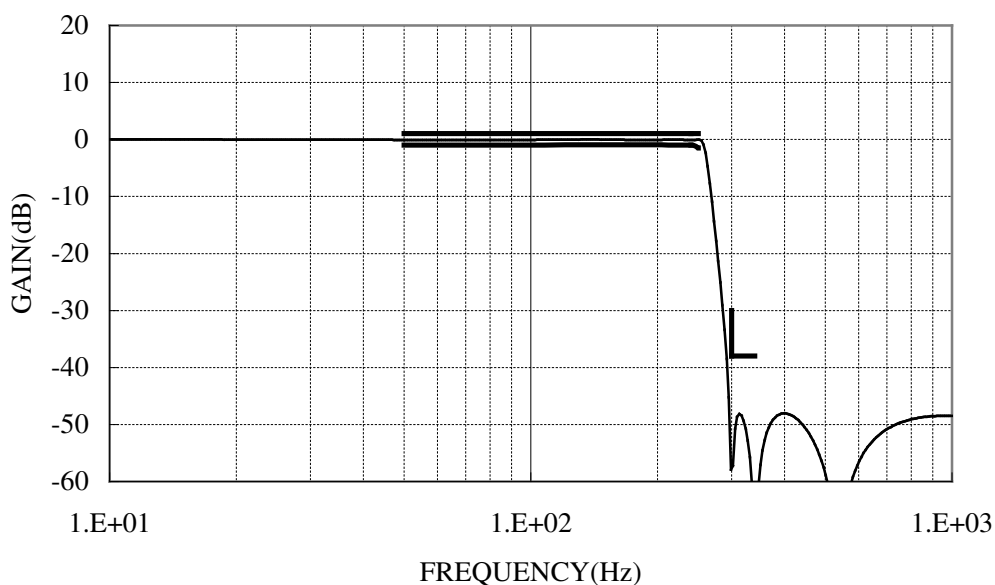
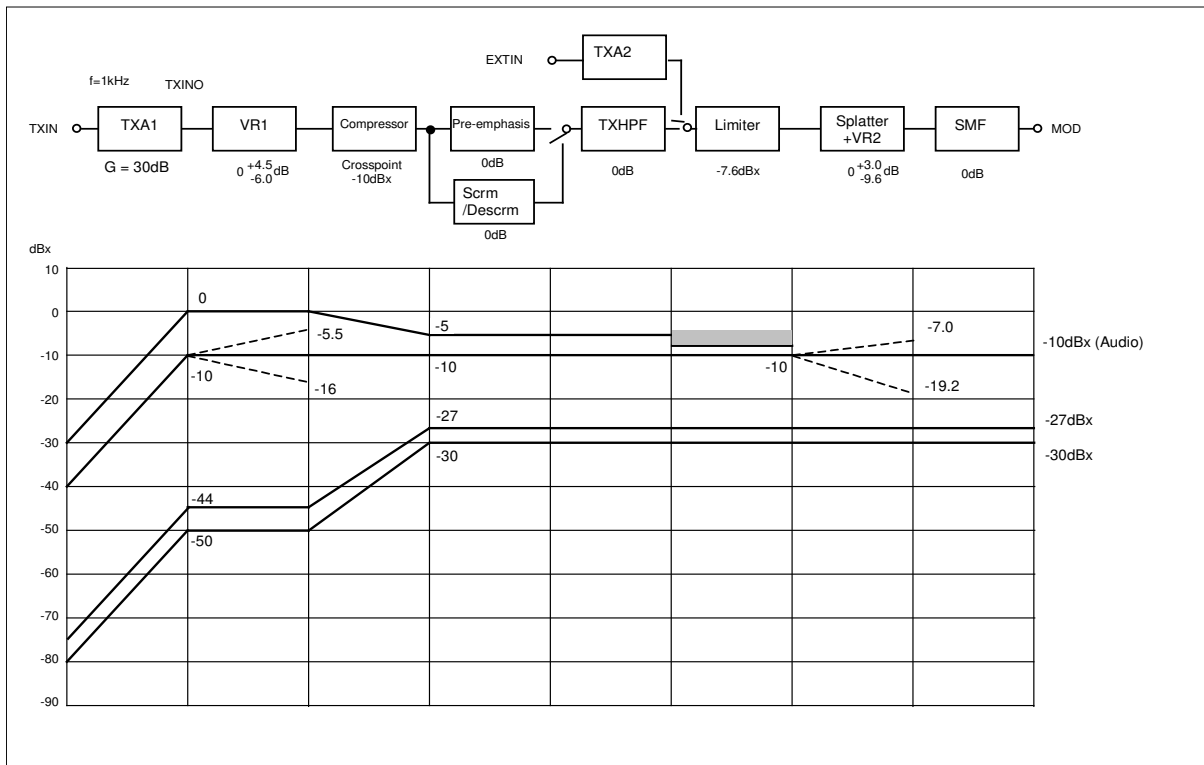

Fig.5 Sub-Audio response characteristics

13. Level Diagram

1) TX system: TXRX=0



2) RX system: TXRX=1

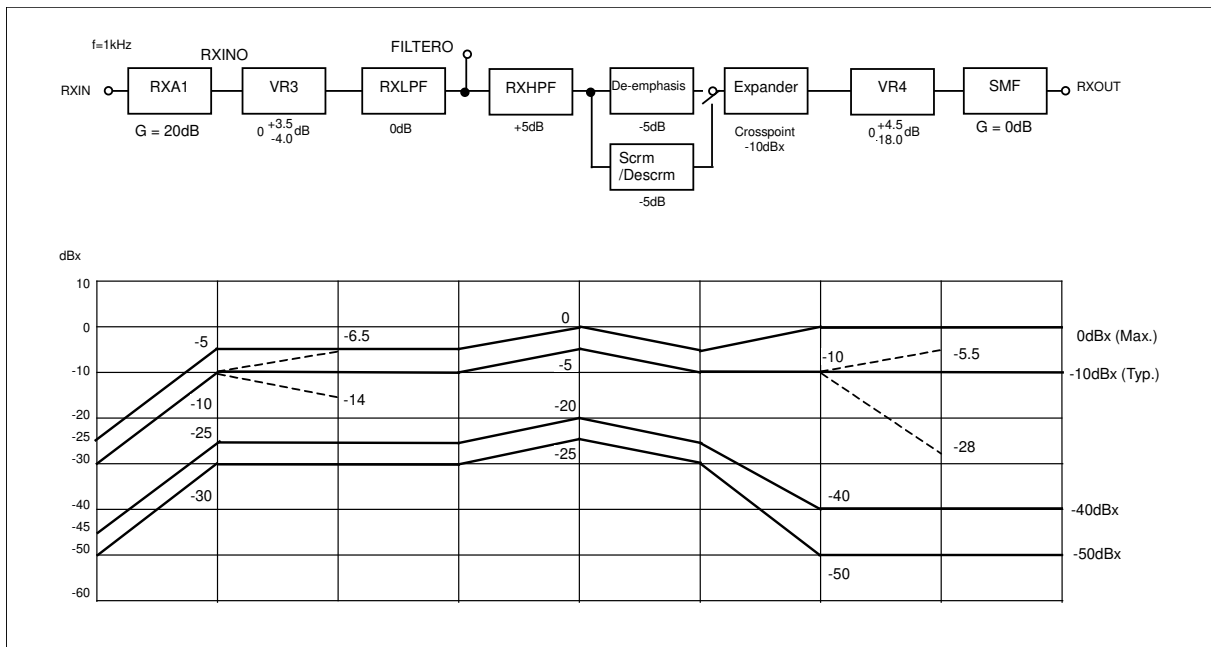

Note) dBx is a standardized notation to match the operating voltage and is defined by equation $0dBx = -5 + 20\log(VDD/2)dBm$.

14. Digital AC Timing

1) Serial Interface Timing

AK2347B is connected to a CPU by three-wired interface through CSN, SCLK and SDATA pins, which can make reading and writing data for control registers. Serial data named SDATA is consist of 1-bit read and write instruction(R/W), 4-bit address (A3 to A0) and 8-bit data(D7 to D0) in one frame.

Write mode

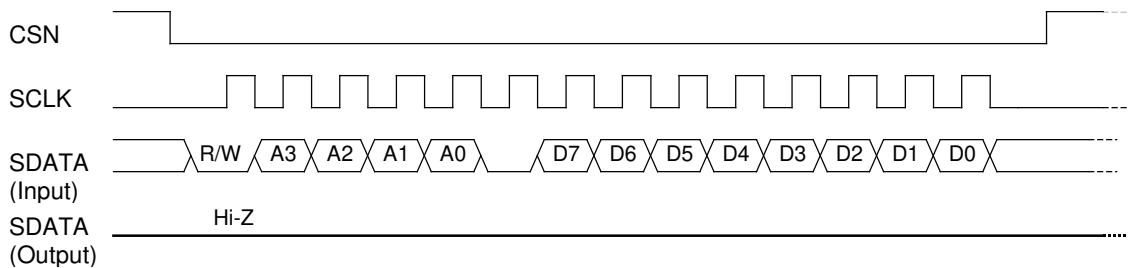

Read mode

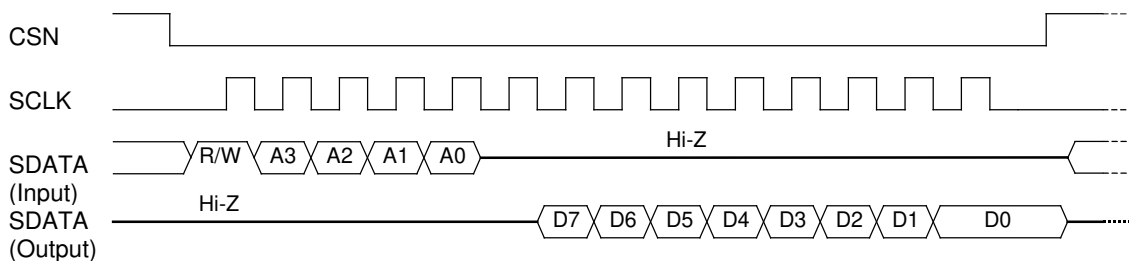

R/W : Instruction bit controls to write data to AK2347B or read back from it. When set to low, AK2347B is in write mode. When set to high, AK2347B is in read mode.

A3 to A0: Register address to be accessed.

D7 to D0: Write or read data to be accessed.

- (1) CSN(Chip select) is normally selected high for disable. When CSN is set to low, serial interface becomes active.
- (2) In write mode, instruction, address and data input from SDATA pin are synchronized and latched with the rising edge of 14 iterations of SCLK clock. Set to low between address A0 and data D7. In read mode, instruction and address are synchronized and latched with the rising edge of 5 iterations of SCLK clock. And the register data are output from SDATA pin synchronized with the falling edge of 9 iterations of SCLK clock. The data between address A0 and data D7 is unstable. A CPU port to SDATA pin is fixed to High-Z during the interval that SDATA outputs the read data.
- (3) AK2347B assumes that write and read is set by 14 iterations SCLK clock while CSN sets to Low. If SCLK iterations are less or more than 14 clocks, serial data would not set properly.

2) Detail Timing Chart

Write mode

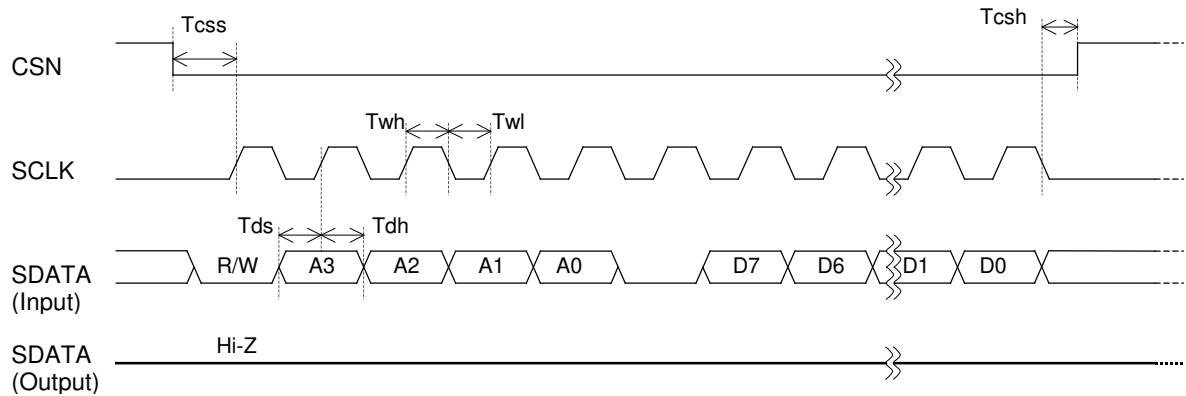

Read mode

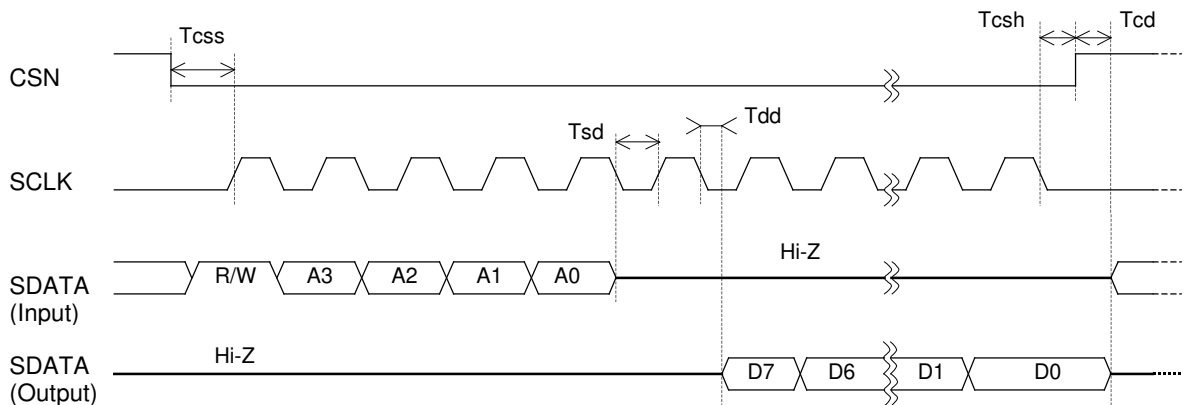

Rising and falling time

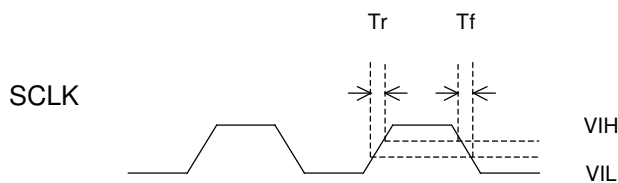

Parameter	Symbol	Condition	Min.	Typ.	Max.	Unit
CSN setup time	T_{css}		100			ns
SDATA setup time	T_{ds}		100			ns
SDATA hold time	T_{dh}		100			ns
SCLK high time	T_{wh}		500			ns
SCLK low time	T_{wl}		500			ns
CSN hold time	T_{csh}		100			ns
SDATA Hi-Z setup time	T_{sd}		500			ns
SCLK to SDATA delay time	T_{dd}	20pF load			500	ns
CSN to SDATA delay time	T_{cd}	20pF load		100		ns
SCLK rising time	T_r				100	ns
SCLK falling time	T_f				100	ns

Note) In digital input timing, rising time is relative to V_{IH} and falling time is relative to V_{IL} .
 In digital output timing, rising time is relative to V_{OH} and falling time is relative to V_{OL} .

15. Register Function Description

1) Register configuration

Address				Function	Data							
A3	A2	A1	A0		D7	D6	D5	D4	D3	D2	D1	D0
0	0	0	0	Control register 1	BS3	BS2	BS1	TXRX	TXSW2	TXSW1	RXSW	MCKSL
0	0	0	1	Control register 2	TC	EM	PCONT	SPL	SCSL	LMT	HPF	SASW
0	0	1	0	Volume register 1	VR54	VR53	VR52	VR51	VR50	VR12	VR11	VR10
0	0	1	1	Volume register 2	FILSW2	FILSW1	VR25	VR24	VR23	VR22	VR21	VR20
0	1	0	0	Volume register 3	–	–	–	–	VR33	VR32	VR31	VR30
0	1	0	1	Volume register 4	–	–	VR45	VR44	VR43	VR42	VR41	VR40
0	1	1	0	Sub-Audio frequency	–	–	SA5	SA4	SA3	SA2	SA1	SA0
0	1	1	1	Software-reset & Revision register	–	–	–	RSTN	REVNUM[3:0]			
1	0/1	0/1	0/1	Reserved	X	X	X	X	X	X	X	X

Note1) The mark “–” means that a write to those bits does not have any influence on the LSI operation and read back the writing data.

Note2) All registers except address 0111 are write and readable registers.

Caution) Never access the mark “X” test register and unlisted bits of VR33 to VR30, VR45 to VR40 and SA5 to SA1. If an access is made to these addresses inadvertently, the LSI operation is not guaranteed.

2) Descriptions of registers

2.1) Control register 1

Address				Data							
A3	A2	A1	A0	D7	D6	D5	D4	D3	D2	D1	D0
0	0	0	0	BS3	BS2	BS1	TXRX	TXSW2	TXSW1	RXSW	MCKSL
When power-down				0	0	0	1	1	1	1	1

2.1.1) Operation mode setting

BS3	BS2	BS1	Mode name	OSC and AGND system	TX and RX audio system	Sub-Audio system
0	0	0	Mode 0 (Power-down)	OFF	OFF	OFF
0	0	1	Mode 1 (standby)	ON	OFF	OFF
0	1	0	Mode 2	ON	ON	OFF
0	1	1	Mode 3	ON	OFF	ON
1	0/1	0/1	Mode 4	ON	ON	ON

2.1.2) TX and RX setting

Data	Item	Function		Remarks
		0	1	
TXRX	TX-RX switch	TX operation *1)	RX operation *2)	*3)
RXSW	RX audio mute	Mute	Normal operation	*4)
MCKSL	Master clock frequency	3.579545MHz	3.6864MHz	

2.1.3) TX path setting

TXSW2	TXSW1	Function	Remarks
1	1	Mute (AGND → Limiter → Splatter)	
0	1	Audio system operation (HPF → Limiter → Splatter)	
1	0	External signal operation (EXTIN pin → Limiter → Splatter)	
0	0	Audio signal and external signal added together (HPF+EXTIN pin → Adder → Limiter → Splatter)	

*1) When TXRX is set to 0 and RXSW is set to 1, the signal input from the TXIN pin can be output to the RXOUT pin. In this case, because use of the Scrambler/Descrambler is inhibited, be sure to set PCONT to 1.

When RXSW is set to 0, the RXOUT pin output is muted.

*2) When TXRX is set to 1 and TXSW2 and TXSW1 are set to 0 and 1 respectively, the signal input from the RXIN pin can be output to the MOD pin. In this case, because use of the Scrambler/Descrambler is inhibited, be sure to set PCONT to 1. When TXSW2 and TXSW1 are set to 1 and 1 respectively, the MOD pin output is muted.

*3) Set the gain level for each circuit block properly according to the level diagrams on page 15.

*4) If RXSW is set to 0, the FILTERO pin output is not muted.

2.2) Control register 2

Address				Data							
A3	A2	A1	A0	D7	D6	D5	D4	D3	D2	D1	D0
0	0	0	1	TC	EM	PCONT	SPL	SCSL	LMT	HPF	SASW
When power-down				1	1	1	1	0	1	1	1

Data	Item	Function		Remarks
		0	1	
TC	Compandpr	OFF (Bypass)	ON (Active)	
SPL	Splatter Cut-off frequency	2.55kHz	3.0kHz	
SCSL	Scrambler carrier frequency MCKSL is set to 0	3.290kHz	3.390kHz	
	MCKSL is set to 1	3.388kHz	3.388kHz	
LMT	Limiter	OFF (Bypass)	ON (Active)	
HPF	TX/RX HPF	OFF (Bypass)	ON (Active)	
SASW	Sub-Audio operation	DIN pin → TSAOUT pin	RXIN pin → RSAOUT pin	

EM	PCONT	Function	Remarks
1	1	Emphasis: ON (Active), Scrambler/Descrambler: OFF (Bypass)	
0	1	Emphasis: OFF (Bypass), Scrambler/Descrambler: OFF (Bypass)	
0/1	0	Emphasis: OFF (Bypass), Scrambler/Descrambler: ON (Active)	

2.3) Volume Register 1

Address				Data							
A3	A2	A1	A0	D7	D6	D5	D4	D3	D2	D1	D0
0	0	1	0	VR54	VR53	VR52	VR51	VR50	VR12	VR11	VR10
When power-down				0	1	1	0	0	1	0	0

VR54	VR53	VR52	VR51	VR50	VR5 gain (dB)
0	0	0	0	0	-6.0
0	0	0	0	1	-5.5
0	0	0	1	0	-5.0
0	0	0	1	1	-4.5
0	0	1	0	0	-4.0
0	0	1	0	1	-3.5
0	0	1	1	0	-3.0
0	0	1	1	1	-2.5
0	1	0	0	0	-2.0
0	1	0	0	1	-1.5
0	1	0	1	0	-1.0
0	1	0	1	1	-0.5
0	1	1	0	0	0.0
0	1	1	0	1	+0.5
0	1	1	1	0	+1.0
0	1	1	1	1	+1.5
1	0	0	0	0	+2.0
1	0	0	0	1	+2.5
1	0	0	1	0	+3.0
1	0	0	1	1	+3.5
1	0	1	0	0	+4.0
1	0	1	0	1	+4.5
1	0	1	1	0	+5.0
1	0	1	1	1	+5.5
1	1	0	0	0	+6.0

VR12	VR11	VR10	VR1 gain (dB)
0	0	0	-6.0
0	0	1	-4.5
0	1	0	-3.0
0	1	1	-1.5
1	0	0	0.0
1	0	1	+1.5
1	1	0	+3.0
1	1	1	+4.5

2.4) Volume Register 2

Address				Data							
A3	A2	A1	A0	D7	D6	D5	D4	D3	D2	D1	D0
0	0	1	1	FILSW2	FILSW1	VR25	VR24	VR23	VR22	VR21	VR20
When power-down				1	1	1	1	0	0	0	0

FILSW2	FILSW1	Function	Remarks
1	1	FILTERO pin output is muted.	
0	1	RXLPF circuit signal is output on FILTERO pin.	
0/1	0	TX/RX_HPF circuit signal is output on FILTERO pin.	

VR25	VR2 gain (dB)
0	-6.4
1	0.0

VR24	VR23	VR22	VR21	VR20	VR2 gain (dB)
0	0	0	0	0	-3.2
0	0	0	0	1	-3.0
0	0	0	1	0	-2.8
0	0	0	1	1	-2.6
0	0	1	0	0	-2.4
0	0	1	0	1	-2.2
0	0	1	1	0	-2.0
0	0	1	1	1	-1.8
0	1	0	0	0	-1.6
0	1	0	0	1	-1.4
0	1	0	1	0	-1.2
0	1	0	1	1	-1.0
0	1	1	0	0	-0.8
0	1	1	0	1	-0.6
0	1	1	1	0	-0.4
0	1	1	1	1	-0.2
1	0	0	0	0	0.0
1	0	0	0	1	+0.2
1	0	0	1	0	+0.4
1	0	0	1	1	+0.6
1	0	1	0	0	+0.8
1	0	1	0	1	+1.0
1	0	1	1	0	+1.2
1	0	1	1	1	+1.4
1	1	0	0	0	+1.6
1	1	0	0	1	+1.8
1	1	0	1	0	+2.0
1	1	0	1	1	+2.2
1	1	1	0	0	+2.4
1	1	1	0	1	+2.6
1	1	1	1	0	+2.8
1	1	1	1	1	+3.0

2.5) Volume Register 3

Address				Data							
A3	A2	A1	A0	D7	D6	D5	D4	D3	D2	D1	D0
0	1	0	0	-	-	-	-	VR33	VR32	VR31	VR30
When power-down				-	-	-	-	1	0	0	0

VR33	VR32	VR31	VR30	VR3 gain (dB)
0	0	0	0	-4.0
0	0	0	1	-3.5
0	0	1	0	-3.0
0	0	1	1	-2.5
0	1	0	0	-2.0
0	1	0	1	-1.5
0	1	1	0	-1.0
0	1	1	1	-0.5
1	0	0	0	0.0
1	0	0	1	+0.5
1	0	1	0	+1.0
1	0	1	1	+1.5
1	1	0	0	+2.0
1	1	0	1	+2.5
1	1	1	0	+3.0
1	1	1	1	+3.5

2.6) Volume Register 4

Address				Data							
A3	A2	A1	A0	D7	D6	D5	D4	D3	D2	D1	D0
0	1	0	1	-	-	VR45	VR44	VR43	VR42	VR41	VR40
When power-down				-	-	0	1	0	0	1	1

VR45	VR44	VR43	VR42	VR41	VR40	VR4 gain (dB)
0	0	0	0	0	0	-18.0
0	0	0	0	0	1	-4.50
0	0	0	0	1	0	-4.25
0	0	0	0	1	1	-4.00
0	0	0	1	0	0	-3.75
0	0	0	1	0	1	-3.50
0	0	0	1	1	0	-3.25
0	0	0	1	1	1	-3.00
0	0	1	0	0	0	-2.75
0	0	1	0	0	1	-2.50
0	0	1	0	1	0	-2.25
0	0	1	0	1	1	-2.00
0	0	1	1	0	0	-1.75
0	0	1	1	0	1	-1.50
0	0	1	1	1	0	-1.25
0	0	1	1	1	1	-1.00
0	1	0	0	0	0	-0.75
0	1	0	0	0	1	-0.50
0	1	0	0	1	0	-0.25
0	1	0	0	1	1	0.00
0	1	0	1	0	0	+0.25
0	1	0	1	0	1	+0.50
0	1	0	1	1	0	+0.75
0	1	0	1	1	1	+1.00
0	1	1	0	0	0	+1.25
0	1	1	0	0	1	+1.50
0	1	1	0	1	0	+1.75
0	1	1	0	1	1	+2.00
0	1	1	1	0	0	+2.25
0	1	1	1	0	1	+2.50
0	1	1	1	1	0	+2.75
0	1	1	1	1	1	+3.00
1	0	0	0	0	0	+3.25
1	0	0	0	0	1	+3.50
1	0	0	0	1	0	+3.75
1	0	0	0	1	1	+4.00
1	0	0	1	0	0	+4.25
1	0	0	1	0	1	+4.50

2.7) Sub-Audio LPF frequency

Address				Data							
A3	A2	A1	A0	D7	D6	D5	D4	D3	D2	D1	D0
0	1	1	0	-	-	SA5	SA4	SA3	SA2	SA1	SA0
When power-down				-	-	1	1	0	0	0	1

SA5	SA4	SA3	SA2	SA1	SA0	Divide *1)	MCKSL=0(3.579545M)		MCKSL=1(3.6864MHz)	
							Cut-off Frequency (Hz)	Target CTCSS (Hz)	Cut-off Frequency (Hz)	Target CTCSS (Hz)
0	0	0	0	0	0	640	59.4	-	61.1	-
0	0	0	0	0	1	630	60.3	-	62.1	-
0	0	0	0	1	0	620	61.3	-	63.1	-
0	0	0	0	1	1	610	62.3	-	64.1	-
0	0	0	1	0	0	600	63.3	-	65.2	-
0	0	0	1	0	1	590	64.4	-	66.3	-
0	0	0	1	1	0	580	65.5	-	67.5	-
0	0	0	1	1	1	570	66.7	-	68.6	-
0	0	1	0	0	0	560	67.8	-	69.9	-
0	0	1	0	0	1	550	69.1	-	71.1	-
0	0	1	0	1	0	540	70.3	-	72.5	67.0
0	0	1	0	1	1	530	71.7	67.0	73.8	-
0	0	1	1	0	0	520	73.1	-	75.2	69.3
0	0	1	1	0	1	510	74.5	69.3	76.7	71.9
0	0	1	1	1	0	500	76.0	-	78.3	-
0	0	1	1	1	1	490	77.6	71.9	79.8	74.4
0	1	0	0	0	0	480	79.2	-	81.5	-
0	1	0	0	0	1	470	80.6	74.4	83.3	77.0
0	1	0	0	1	0	460	82.6	77.0	85.1	79.7
0	1	0	0	1	1	450	84.4	-	87.0	-
0	1	0	1	0	0	440	86.3	79.7	89.0	82.5
0	1	0	1	0	1	430	88.4	82.5	91.0	85.4
0	1	0	1	1	0	420	90.4	-	93.2	-
0	1	0	1	1	1	410	92.7	85.4	95.5	88.5
0	1	1	0	0	0	400	95.0	88.5	97.8	91.5
0	1	1	0	0	1	390	97.4	91.5	100.3	-
0	1	1	0	1	0	380	100.0	-	103.0	94.8
0	1	1	0	1	1	370	102.7	94.8	105.8	97.4
0	1	1	1	0	0	360	105.6	97.4	108.7	100.0
0	1	1	1	0	1	350	108.6	100.0	111.8	103.5
0	1	1	1	1	0	340	111.8	103.5	115.1	107.2
0	1	1	1	1	1	330	115.1	107.2	118.6	110.9