



Chipsmall Limited consists of a professional team with an average of over 10 year of expertise in the distribution of electronic components. Based in Hongkong, we have already established firm and mutual-benefit business relationships with customers from,Europe,America and south Asia,supplying obsolete and hard-to-find components to meet their specific needs.

With the principle of "Quality Parts,Customers Priority,Honest Operation,and Considerate Service",our business mainly focus on the distribution of electronic components. Line cards we deal with include Microchip,ALPS,ROHM,Xilinx,Pulse,ON,Everlight and Freescale. Main products comprise IC,Modules,Potentiometer,IC Socket,Relay,Connector.Our parts cover such applications as commercial,industrial, and automotives areas.

We are looking forward to setting up business relationship with you and hope to provide you with the best service and solution. Let us make a better world for our industry!



Contact us

Tel: +86-755-8981 8866 Fax: +86-755-8427 6832

Email & Skype: info@chipsmall.com Web: www.chipsmall.com

Address: A1208, Overseas Decoration Building, #122 Zhenhua RD., Futian, Shenzhen, China





AK4127

192kHz / 24Bit High Performance Asynchronous SRC

GENERAL DESCRIPTION

The AK4127 is a stereo digital sample rate converter (SRC). The input sample rate ranges from 8kHz to 216kHz. The output sample rate is from 8kHz to 216kHz. The system can take very simple configuration because the AK4127 has an internal PLL and does not need any master clock at slave mode. The AK4127 is suitable for the application interfacing to different sample rates such as high-end Car Audio and DVD recorder.

FEATURES

1. SRC

- Asynchronous Sample Rate Converter
- Input Sample Rate Range (fsi): 8kHz ~ 216kHz
- Output Sample Rate (fso): 8kHz ~ 216kHz
- Input to Output Sample Rate Ratio: 1/6 to 6
- THD+N: -130dB
- Dynamic Range: 140dB (A-weighted)
- I/F format: MSB justified, LSB justified, I²S compatible and TDM
- PLL for Internal Operation Clock
- Clock for Master mode: 128/192/256/384/512/768fsi, 128/256/384/512/768fso
- SRC Bypass mode (Master/Slave)
- Soft Mute Function

2. Power Supply

- AVDD, DVDD: 3.0 ~ 3.6V (typ. 3.3V)

3. Ta = -40 ~ 85°C

4. Package: 30pin VSOP

5. AK4124/5 Pin-compatible

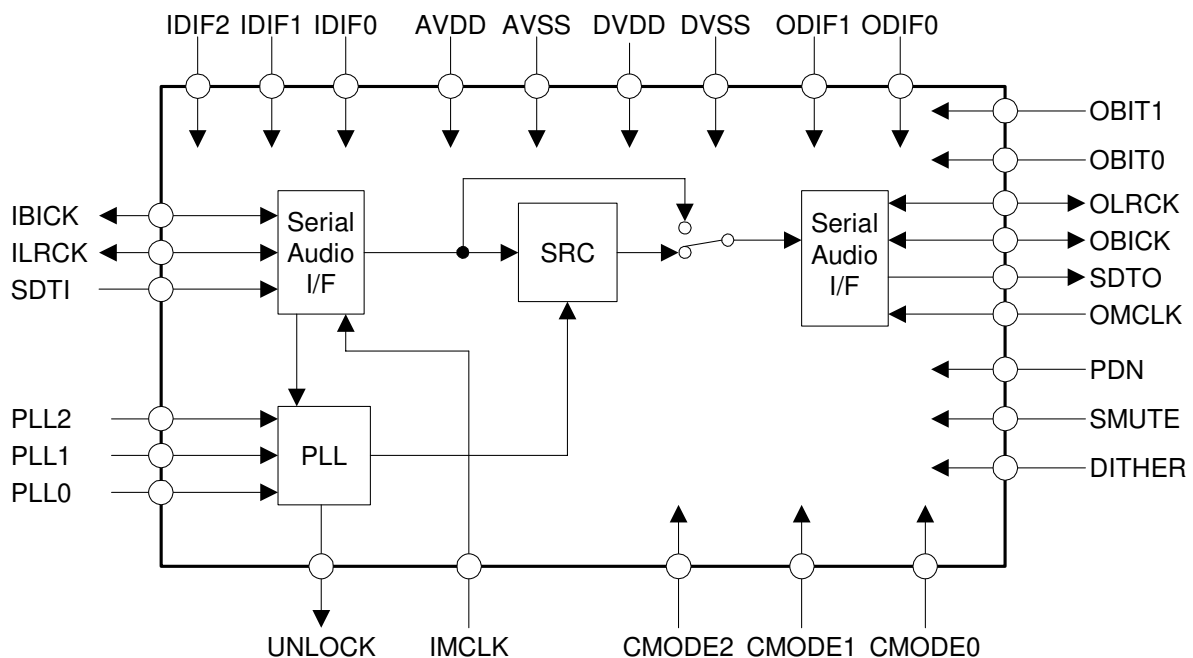

TABLE OF CONTENTS

GENERAL DESCRIPTION.....	1
FEATURES	1
■ Ordering Guide	3
■ Pin Layout	3
■ Compatibility with AK4125	4
PIN/FUNCTION	5
■ Handling of Unused pins.....	6
ABSOLUTE MAXIMUM RATINGS	6
RECOMMENDED OPERATING CONDITIONS	6
SRC CHARACTERISTICS	7
FILTER CHARACTERISTICS	8
DC CHARACTERISTICS	9
SWITCHING CHARACTERISTICS	9
■ Timing Diagram	11
OPERATION OVERVIEW	13
■ System Clock & Audio Interface Format for Input PORT.....	13
■ System Clock & Audio Interface Format for Output PORT	15
■ Cascade TDM Mode	18
■ Soft Mute Operation.....	19
■ Dither	20
■ System Reset	20
■ Internal Reset Function for Clock Change	21
■ Sequence of Changing Clocks	21
■ UNLOCK pin.....	21
■ PLL Loop Filter.....	22
SYSTEM DESIGN.....	23
PACKAGE	27
■ Material & Lead finish	27
MARKING	28
REVISION HISTORY	28
■ Sequence of changing clocks	28
IMPORTANT NOTICE	29

■ Ordering Guide

AK4127VF
AKD4127

-40 ~ +85°C 30pin VSOP (0.65mm pitch)
Evaluation Board for AK4127

■ Pin Layout

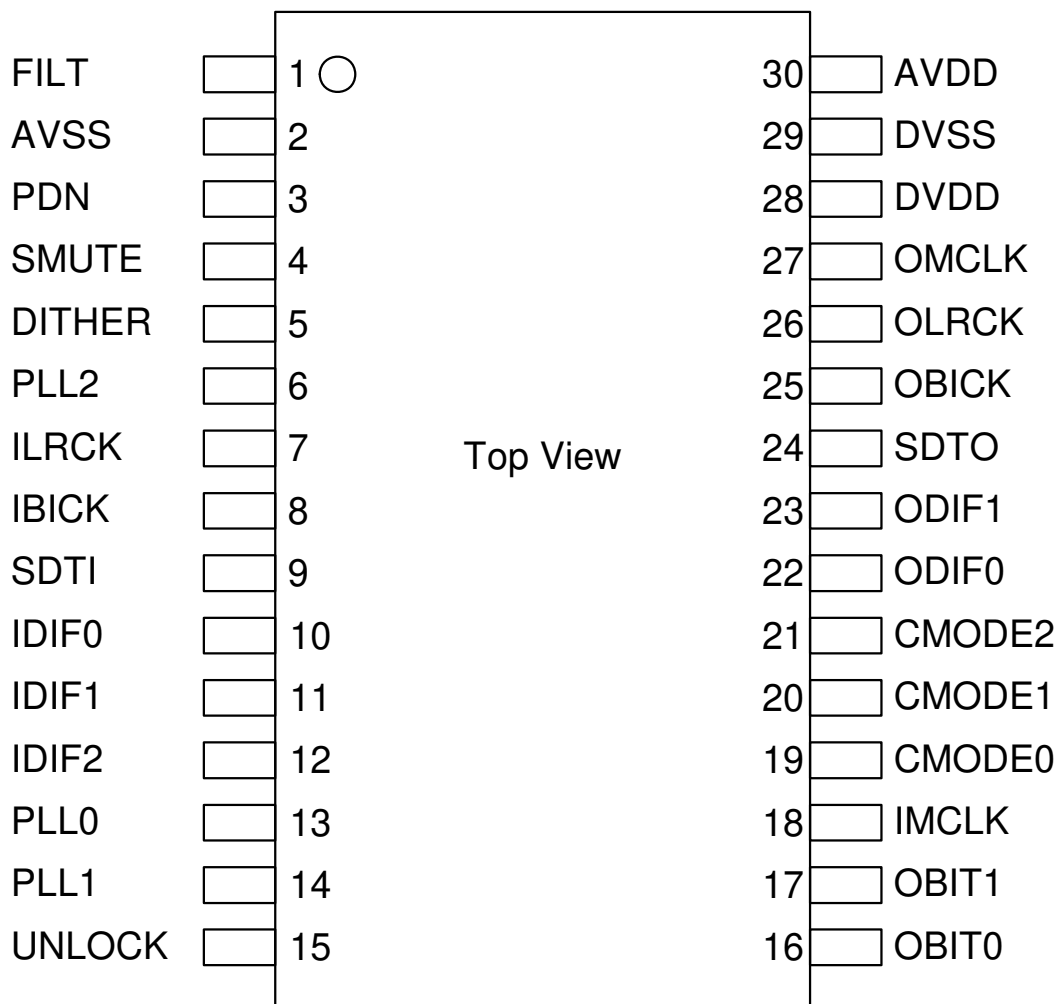

■ **Compatibility with AK4125**

Item	AK4125	AK4127
TDM Mode	-	X
Slave Mode at Bypass Mode	-	X
OMCLK pin	OMCLK	Normal Mode: OMCLK TDM Mode: TDMIN
OMCLK=192fso for Output PORT (at Master Mode)	X	-

(-: Not available, X: Available)

PIN/FUNCTION			
No.	Pin Name	I/O	Function
1	FILT	O	PLL Loop Filter Pin, Hi-Z when PDN pin = "L".
2	AVSS	-	Analog Ground Pin
3	PDN	I	Power-Down Mode Pin "H": Power up, "L": Power down reset and initializes the control register.
4	SMUTE	I	Soft Mute Pin "H" : Soft Mute, "L" : Normal Operation
5	DITHER	I	Dither Enable Pin "H" : Dither ON, "L" : Dither OFF
6	PLL2	I	PLL Mode Select 2 Pin
7	ILRCK	I/O	Input Channel Clock Pin, Output "L" when PDN = "L" and master mode.
8	IBICK	I/O	Audio Serial Data Clock Pin, Output "L" when PDN = "L" and master mode.
9	SDTI	I	Audio Serial Data Input Pin
10	IDIF0	I	Audio Interface Format 0 Pin for Input PORT
11	IDIF1	I	Audio Interface Format 1 Pin for Input PORT
12	IDIF2	I	Audio Interface Format 2 Pin for Input PORT
13	PLL0	I	PLL Mode Select 0 Pin
14	PLL1	I	PLL Mode Select 1 Pin
15	UNLOCK	O	Unlock Status Pin, Output "H" when PDN = "L"
16	OBIT0	I	Bit Length Select 0 Pin for Output Data
17	OBIT1	I	Bit Length Select 1 Pin for Output Data
18	IMCLK	I	Master Clock Input Pin for Input PORT
19	CMODE0	I	Clock Mode Select 0 Pin
20	CMODE1	I	Clock Mode Select 1 Pin
21	CMODE2	I	Clock Mode Select 2 Pin
22	ODIF0	I	Audio Interface Format 0 Pin for Output PORT
23	ODIF1	I	Audio Interface Format 1 Pin for Output PORT
24	SDTO	O	Audio Serial Data Output Pin for Output PORT, Output "L" when PDN pin = "L"
25	OBICK	I/O	Audio Serial Data Clock Pin for Output PORT Output "L" when PDN = "L" and master mode.
26	OLRCK	I/O	Output Channel Clock Pin for Output PORT Output "L" when PDN = "L" and master mode.
27	OMCLK	I	Master Clock/TDM Data Input Pin for Output PORT OMCLK: Master Clock Input Pin (except for PLL2/1/0 pin = "L/H/H") TDMIN: TDM Data Input Pin (PLL2/1/0 pin = "L/H/H")
28	DVDD	-	Digital Power Supply Pin, 3.0 ~ 3.6V
29	DVSS	-	Digital Ground Pin
30	AVDD	-	Analog Power Supply Pin, 3.0 ~ 3.6V

Note: All input pins must not be left floating.

■ Handling of Unused pins

The unused digital I/O pins should be processed appropriately as below.

Classification	Pin Name	Setting
Analog	FILT	This pin should be open.
Digital	SMUTE, DITHER	These pins should be connected to DVSS.
	IMCLK, OMCLK	These pins should be connected to DVSS in slave mode.
	UNLOCK	This pin should be open.

ABSOLUTE MAXIMUM RATINGS

(AVSS=DVSS=0V; Note 1)

Parameter		Symbol	min	max	Units
Power Supplies:	Analog	AVDD	-0.3	4.6	V
	Digital	DVDD	-0.3	4.6	V
	AVSS – DVSS (Note 2)	ΔGND	-	0.3	V
Input Current, Any Pin Except Supplies		IIN	-	±10	mA
Digital Input Voltage (Note 3)		VIND	-0.3	DVDD+0.3	V
Ambient Temperature (Power applied)		Ta	-40	85	°C
Storage Temperature		Tstg	-65	150	°C

Note 1. All voltages with respect to ground.

Note 2. AVSS, BVSS and DVSS must be connected to the same ground.

Note 3. PND, SMUTE, DITHER, PLL2, ILRCK, IBICK, SDTI, IDIF0, IDIF1, IDIF2, PLL0, PLL1, OBIT0, OBIT1, IMCLK, CMODE0, CMODE1, CMODE2, ODIF0, ODIF1, OBICK, OLRCK and OMCLK

WARNING: Operation at or beyond these limits may result in permanent damage to the device.
Normal operation is not guaranteed at these extremes.

RECOMMENDED OPERATING CONDITIONS

(AVSS=DVSS=0V; Note 1)

Parameter		Symbol	min	typ	max	Units
Power Supplies (Note 4)	Analog	AVDD	3.0	3.3	3.6	V
	Digital	DVDD	3.0	3.3	AVDD	V

Note 4. The power up sequence between AVDD and DVDD is not important.

WARNING: AKM assumes no responsibility for the usage beyond the conditions in this datasheet.

SRC CHARACTERISTICS

(Ta=25°C; AVDD=DVDD=3.3V; AVSS=DVSS=0V; data = 24bit; measurement bandwidth = 20Hz ~ FSO/2; unless otherwise specified.)

Parameter	Symbol	min	typ	max	Units
SRC Characteristics:					
Resolution				24	Bits
Input Sample Rate	FSI	8		216	kHz
Output Sample Rate	FSO	8		216	kHz
THD+N (Input = 1kHz, 0dBFS, Note 5)					
FSO/FSI = 44.1kHz/48kHz		-	-130	-	dB
FSO/FSI = 48kHz/44.1kHz		-	-124	-	dB
FSO/FSI = 48kHz/192kHz		-	-133	-	dB
FSO/FSI = 192kHz/48kHz		-	-124	-	dB
Worst Case (FSO/FSI = 32kHz/176.4kHz)		-	-	-91	dB
Dynamic Range (Input = 1kHz, -60dBFS, Note 5)					
FSO/FSI = 44.1kHz/48kHz		-	136	-	dB
FSO/FSI = 48kHz/44.1kHz		-	136	-	dB
FSO/FSI = 48kHz/192kHz		-	136	-	dB
FSO/FSI = 192kHz/48kHz		-	132	-	dB
Worst Case (FSO/FSI = 48kHz/32kHz)		132	-	-	dB
Dynamic Range (Input = 1kHz, -60dBFS, A-weighted, Note 5)					
FSO/FSI = 44.1kHz/48kHz		-	140	-	dB
Ratio between Input and Output Sample Rate	FSO/FSI	1/6		6	-

Note 5. Measured by Audio Precision System Two Cascade

FILTER CHARACTERISTICS

(Ta=25°C; AVDD=DVDD=3.0 ~ 3.6V)

Parameter		Symbol	min	typ	max	Units
Digital Filter						
Passband -0.01dB	0.985 ≤ FSO/FSI ≤ 6.000	PB	0		0.4583FSI	kHz
	0.905 ≤ FSO/FSI < 0.985	PB	0		0.4167FSI	kHz
	0.714 ≤ FSO/FSI < 0.905	PB	0		0.3195FSI	kHz
	0.656 ≤ FSO/FSI < 0.714	PB	0		0.2852FSI	kHz
	0.536 ≤ FSO/FSI < 0.656	PB	0		0.2182FSI	kHz
	0.492 ≤ FSO/FSI < 0.536	PB	0		0.2177FSI	kHz
	0.452 ≤ FSO/FSI < 0.492	PB	0		0.1948FSI	kHz
	0.357 ≤ FSO/FSI < 0.452	PB	0		0.1458FSI	kHz
	0.324 ≤ FSO/FSI < 0.357	PB	0		0.1302FSI	kHz
	0.246 ≤ FSO/FSI < 0.324	PB	0		0.0917FSI	kHz
	0.226 ≤ FSO/FSI < 0.246	PB	0		0.0826FSI	kHz
	0.1667 ≤ FSO/FSI < 0.226	PB	0		0.0583FSI	kHz
Stopband	0.985 ≤ FSO/FSI ≤ 6.000	SB	0.5417FSI			kHz
	0.905 ≤ FSO/FSI < 0.985	SB	0.5021FSI			kHz
	0.714 ≤ FSO/FSI < 0.905	SB	0.3965FSI			kHz
	0.656 ≤ FSO/FSI < 0.714	SB	0.3643FSI			kHz
	0.536 ≤ FSO/FSI < 0.656	SB	0.2974FSI			kHz
	0.492 ≤ FSO/FSI < 0.536	SB	0.2813FSI			kHz
	0.452 ≤ FSO/FSI < 0.492	SB	0.2604FSI			kHz
	0.357 ≤ FSO/FSI < 0.452	SB	0.2116FSI			kHz
	0.324 ≤ FSO/FSI < 0.357	SB	0.1969FSI			kHz
	0.246 ≤ FSO/FSI < 0.324	SB	0.1573FSI			kHz
	0.226 ≤ FSO/FSI < 0.246	SB	0.1471FSI			kHz
	0.1667 ≤ FSO/FSI < 0.226	SB	0.1020FSI			kHz
Passband Ripple		PR			±0.01	dB
Stopband Attenuation	0.985 ≤ FSO/FSI ≤ 6.000	SA	121.2			dB
	0.905 ≤ FSO/FSI < 0.985	SA	121.4			dB
	0.714 ≤ FSO/FSI < 0.905	SA	115.3			dB
	0.656 ≤ FSO/FSI < 0.714	SA	116.9			dB
	0.536 ≤ FSO/FSI < 0.656	SA	114.6			dB
	0.492 ≤ FSO/FSI < 0.536	SA	100.2			dB
	0.452 ≤ FSO/FSI < 0.492	SA	103.3			dB
	0.357 ≤ FSO/FSI < 0.452	SA	102.0			dB
	0.324 ≤ FSO/FSI < 0.357	SA	103.6			dB
	0.246 ≤ FSO/FSI < 0.324	SA	104.0			dB
0.226 ≤ FSO/FSI < 0.246	SA	103.3			dB	
0.1667 ≤ FSO/FSI < 0.226	SA	73.2			dB	
Group Delay	(Note 6)	GD	-	56	-	1/fs

Note 6. This delay is the a period from the rising edge of ILRCK, just after the data is input, to the rising edge of OLRCK, just after the data is output, when there is no phase difference between ILRCK and OLRCK.

DC CHARACTERISTICS

(Ta=25°C; AVDD= DVDD=3.0 ~ 3.6V)

Parameter	Symbol	min	typ	max	Units
High-Level Input Voltage	VIH	70%DVDD	-	-	V
Low-Level Input Voltage	VIL	-	-	30%DVDD	V
High-Level Output Voltage (Iout=-400μA)	VOH	DVDD-0.4	-	-	V
Low-Level Output Voltage (Iout=400μA)	VOL	-	-	0.4	V
Input Leakage Current	Iin	-	-	±10	μA
Power Supplies					
Power Supply Current					
Normal operation (PDN pin = "H")					
FSI=FSO=48kHz at Slave Mode: AVDD=DVDD=3.3V			15		mA
FSI=FSO=192kHz at Master Mode: AVDD=DVDD=3.3V			65		mA
: AVDD=DVDD=3.6V				100	mA
Power down (PDN pin = "L") (Note 7)					
AVDD+DVDD			10	100	μA

Note 7. All digital input pins are held DVSS.

SWITCHING CHARACTERISTICS

(Ta=25°C; AVDD=DVDD=3.0 ~ 3.6V; CL=20pF)

Parameter	Symbol	min	typ	max	Units
Master Clock Timing					
Frequency	fCLK	1.024		41.472	MHz
Pulse Width Low	tCLKL	0.4/fCLK			ns
Pulse Width High	tCLKH	0.4/fCLK			ns
LRCK for Input data (ILRCK)					
Frequency	fs	8		216	kHz
Duty Cycle	Duty	48	50	52	%
	Duty		50		%
LRCK for Output data (OLRCK)					
Frequency	fs	8		216	kHz
Duty Cycle	Duty	48	50	52	%
	Duty		50		%
LRCK for TDM Mode (OLRCK)					
Frequency	fs	8		48	kHz
"H" time	tLRH	1/256fs			ns
"L" time	tLRL	1/256fs			ns
Audio Interface Timing					
Input PORT (Slave mode)					
IBICK Period (8kHz ~ 54kHz)	tBCK	1/256fs			ns
(54kHz ~ 108kHz)	tBCK	1/128fs			ns
(108kHz ~ 216kHz)	tBCK	1/64fs			ns
IBICK Pulse Width Low	tBCKL	27			ns
Pulse Width High	tBCKH	27			ns
ILRCK Edge to IBICK "↑" (Note 8)	tLRB	15			ns
IBICK "↑" to ILRCK Edge (Note 8)	tBLR	15			ns
SDTI Hold Time from IBICK "↑"	tSDH	15			ns
SDTI Setup Time to IBICK "↑"	tSDS	15			ns

Input PORT (Master mode)					
IBICK Frequency	fBCK		64fs		Hz
IBICK Duty	dBCK		50		%
IBICK “↓” to ILRCK	tMBLR	-20		20	ns
SDTI Hold Time from IBICK “↑”	tSDH	15			ns
SDTI Setup Time to IBICK “↑”	tSDS	15			ns
Output PORT (Slave mode)					
OBICK Period (8kHz ~ 54kHz)	tBCK	1/256fs			ns
(54kHz ~ 108kHz)	tBCK	1/128fs			ns
(108kHz ~ 216kHz)	tBCK	1/64fs			ns
OBICK Pulse Width Low	tBCKL	27			ns
Pulse Width High	tBCKH	27			ns
OLRCK Edge to OBICK “↑” (Note 8)	tLRB	20			ns
OBICK “↑” to OLRCK Edge (Note 8)	tBLR	20			ns
OLRCK to SDTO (MSB) (Except I ² S mode)	tLRS			20	ns
OBICK “↓” to SDTO	tBSD			20	ns
Output PORT (TDM slave mode)					
OBICK Period	tBCK	81			ns
OBICK Pulse Width Low	tBCKL	32			ns
Pulse Width High	tBCKH	32			ns
OLRCK Edge to BICK “↑” (Note 8)	tLRB	20			ns
OBICK “↑” to LRCK Edge (Note 8)	tBLR	20			ns
OBICK “↓” to SDTO	tBSD			20	ns
TDMIN Hold Time	tSDH	20			ns
TDMIN Setup Time	tSDS	10			ns
Output PORT (Master mode)					
OBICK Frequency	fBCK		64fs		Hz
OBICK Duty	dBCK		50		%
OBICK “↓” to OLRCK	tMBLR	-20		20	ns
OBICK “↓” to SDTO	tBSD	-20		20	ns
Reset Timing					
PDN Pulse Width (Note 9)	tPD	150			ns

Note 8. BICK rising edge must not occur at the same time as LRCK edge.

Note 9. The AK4127 can be reset by bringing the PDN pin = “L”.

■ Timing Diagram

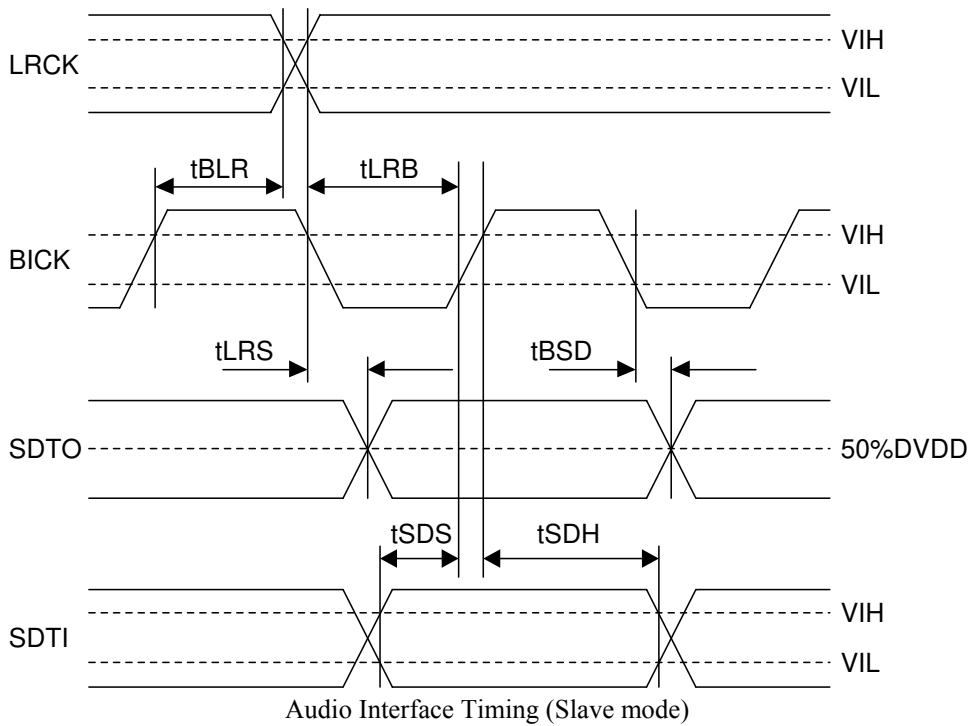
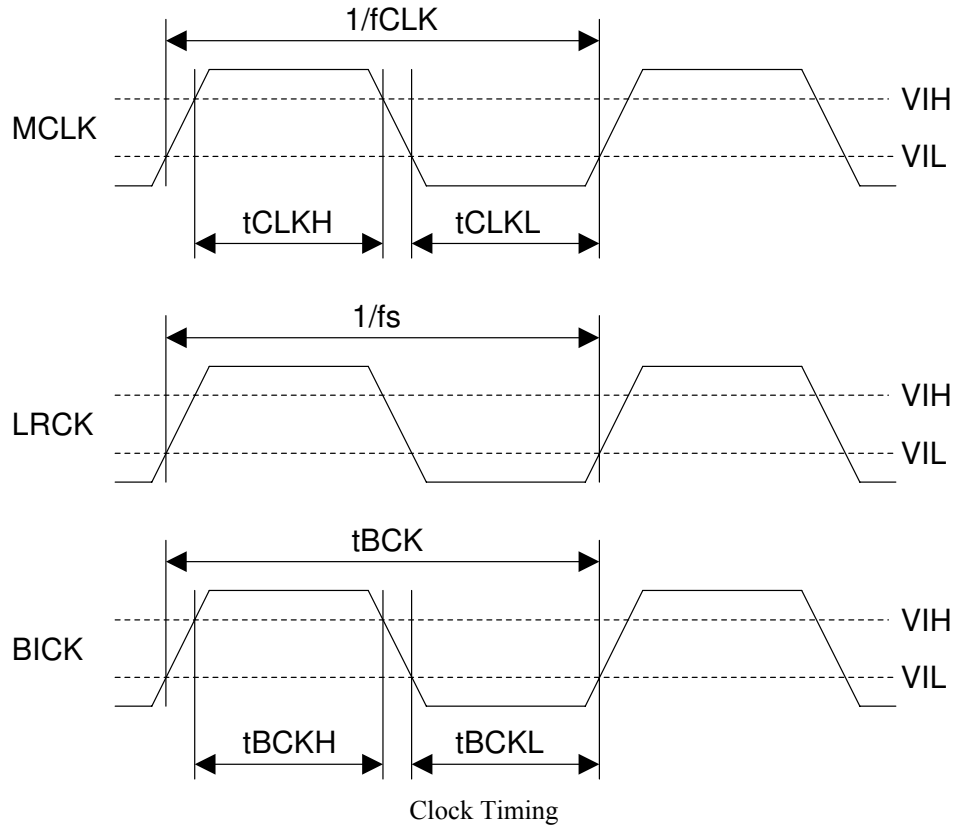

Note : BICK shows IBICK and OBICK, LRCK shows ILRCK and OLRCK.

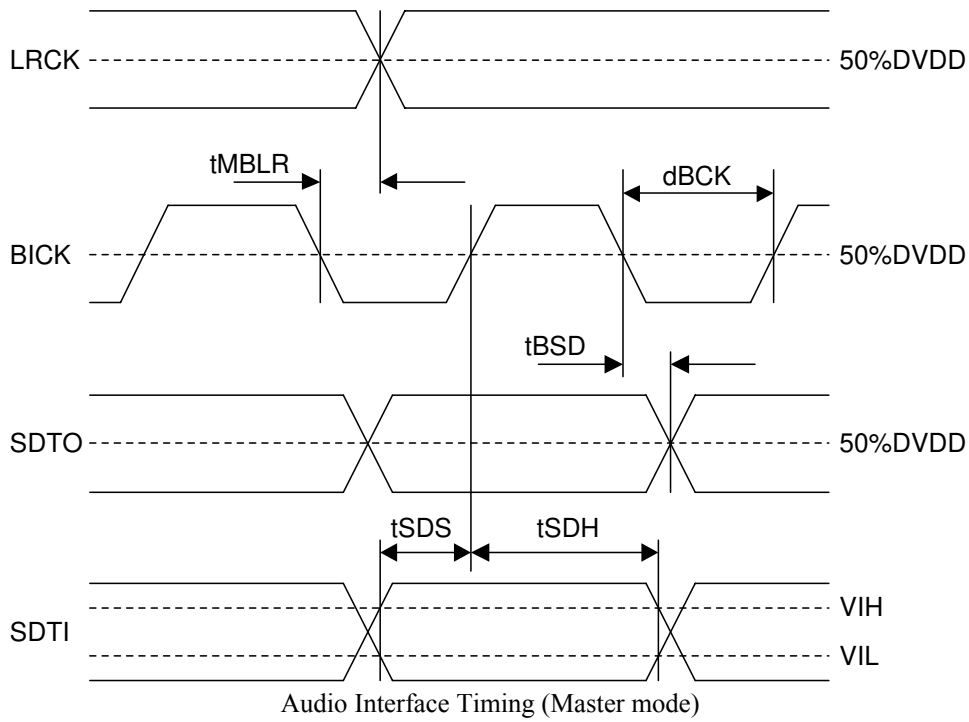

Note : BICK shows IBICK and OBICK, LRCK shows ILRCK and OLRCK.

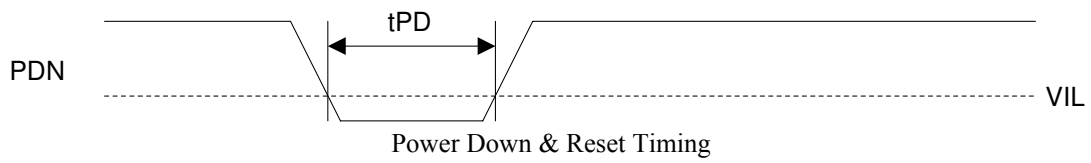

OPERATION OVERVIEW

■ System Clock & Audio Interface Format for Input PORT

The input port works in master mode or slave mode. An internal system clock is created by the internal PLL using ILRCK (Mode 0 ~ 3 of Table 2) or IBICK (Mode 4 ~ 7 of Table 2) in slave mode. The MCLK is not needed in slave mode. And an internal system clock is created by IMCLK (Mode 8 ~ 15 of Table 2) in master mode. The PLL2-0 pins and IDIF2-0 pins select the master/slave and PLL mode. The PLL2-0 pins and IDIF2-0 pins should be controlled when the PDN pin = "L". When the PLL2-0 pin = "L/H/H", setting the output port slave (CMODE2-0pin = "H/L/L" or "H/H/L") enables the TDM mode at the output port.

The IDIF2-0 pins select the audio interface format for the input port. The audio data is MSB first, 2's compliment format. The SDTI is latched on the rising edge of IBICK. Select the audio interface format when the PDN pin = "L". When in BYPASS mode, both IBICK and OBICK are fixed to 64fs.

Mode	IDIF2	IDIF1	IDIF0	SDTI Format	ILRCK	IBICK	IBICK Freq	Master / Slave
0	L	L	L	16bit, LSB justified	Input	Input	≥ 32fsi	Slave
1	L	L	H	20bit, LSB justified			≥ 40fsi	
2	L	H	L	24/20bit, MSB justified			≥ 48fsi	
3	L	H	H	24/16bit, I ² S Compatible			≥ 48fsi or 32fsi	
4	H	L	L	24bit, LSB justified			≥ 48fsi	
5	H	L	H	24bit, MSB justified	Output	Output	64fs	Master
6	H	H	L	24bit, I ² S Compatible			64fs	
7	H	H	H	Reserved				

Table 1. Input Audio Interface Format (Input PORT)

Mode	Master / Slave	PLL2	PLL1	PLL0	ILRCK Freq	IBICK Freq	IMCLK	SMUTE (Note 14)
0	Slave IMCLK = DVSS IBICK = Input ILRCK = Input	L	L	L	8k ~ 96kHz	Depending on IDIF2-0 (Note 11)	Not needed. (Note 13)	Manual
1		L	L	H	8k ~ 216kHz			
2		L	H	L	16k ~ 216kHz (Note 10)			
3		L	H	H	8k ~ 216kHz (Note 11)	32fsi (Note 12)	Not needed. (Note 13)	Manual
4		H	L	L		64fsi		
5		H	L	H		128fsi		
6		H	H	L		64fsi		
7	H	H	H	64fsi	64fsi	Semi-Auto		
8	Master IMCLK = Input IBICK = Output ILRCK = Output	L	L	L	8k ~ 216kHz	64fsi	128fsi	Manual
9		L	L	H	8k ~ 108kHz		256fsi	
10		L	H	L	8k ~ 54kHz		512fsi	Semi-Auto
11		L	H	H	8k ~ 216kHz		128fsi	
12		H	L	L	8k ~ 216kHz		192fsi	Manual
13		H	L	H	8k ~ 108kHz		384fsi	
14		H	H	L	8k ~ 54kHz		768fsi	
15		H	H	H	8k ~ 216kHz		192fsi	

Table 2. PLL Setting (Input PORT)

Note 10. PLL lock rage is changed by the value of R and C connected FILT pin. Refer to "PLL Loop Filter".

Note 11. The IBCIK must be continuous except when the clocks are changed.

Note 12. IBCIK = 32fsi is supported only 16bit LSB justified and I²S Compatible.

Note 13. Fixed to DVSS.

Note 14. Refer to "Soft Mute Operation" for Manual mode and Semi-Auto mode.

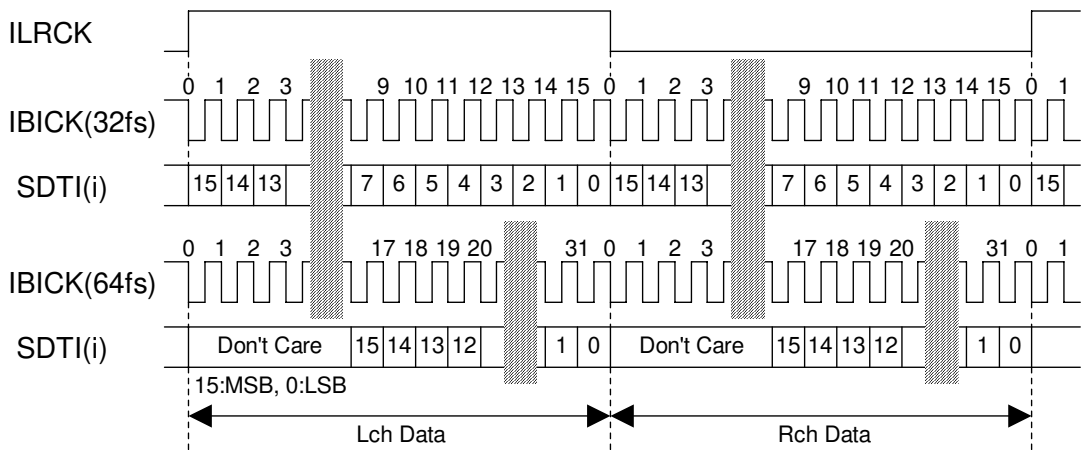

Figure 1. Mode 0 Timing

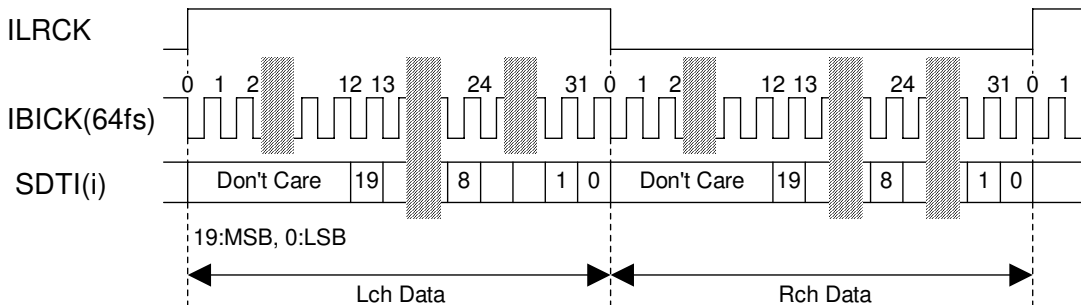

Figure 2. Mode 1 Timing

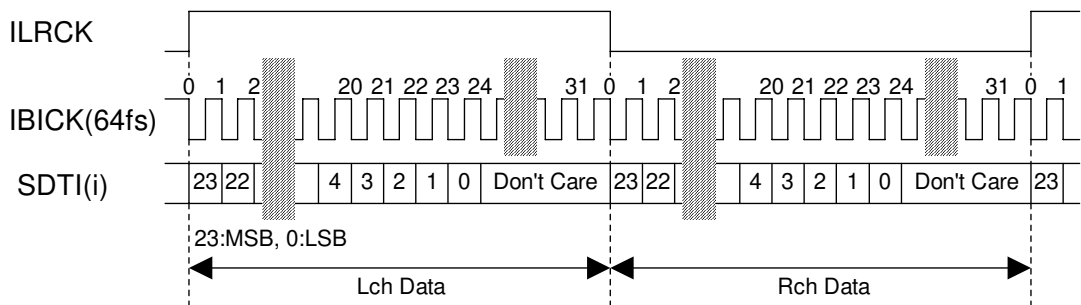

Figure 3. Mode 2,5 Timing (24bit MSB)

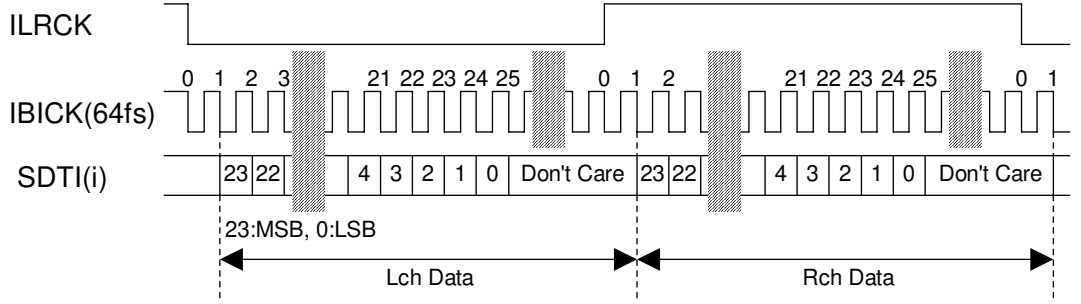

Figure 4. Mode 3, 6 Timing (24bit I²S)

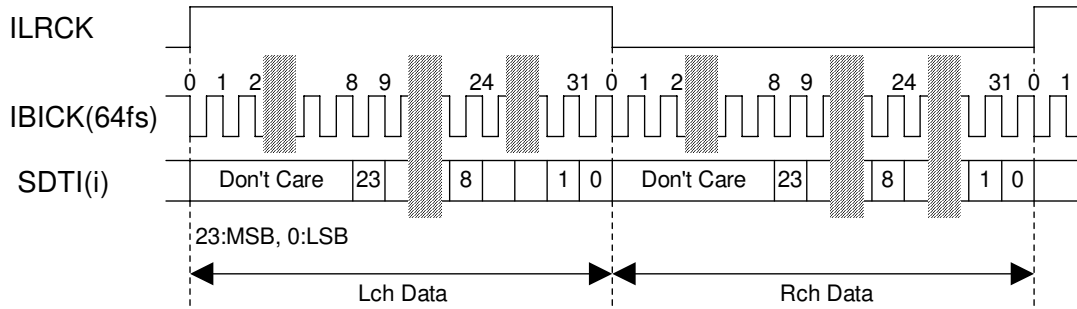

Figure 5. Mode 4 Timing

■ System Clock & Audio Interface Format for Output PORT

The output port works in master mode or slave mode. The MCLK is not needed in slave mode. The CMODE2-0 pins select the master/slave and bypass mode. The CMODE2-0 pins should be controlled when the PDN pin = “L”.

The ODIF1-0 pins and OBIT1-0 pins select the audio interface format for the output port. The audio data is MSB first, 2’s compliment format. The SDTO is clocked out on the falling edge of OBICK. Select the audio interface format when the PDN pin = “L”.

When in BYPASS mode, both IBICK and OBICK are fixed to 64fs. When the PLL2-0 pin= “L/H/H”, setting the output port slave (CMODE2-0pin = “H/L/L” or “H/H/L”) enables the TDM mode at the output port. The OMCLK pin changes to TDMIN pin for TDM data input in TDM mode.

Mode	CMODE 2	CMODE 1	CMODE0	Master / Slave	OMCLK	fso
0	L	L	L	Master	256fso	8k ~ 108kHz
1	L	L	H	Master	384fso	8k ~ 108kHz
2	L	H	L	Master	512fso	8k ~ 54kHz
3	L	H	H	Master	768fso	8k ~ 54kHz
4	H	L	L	Slave	Not used. Set to DVSS. (Note 15)	8k ~ 216kHz
5	H	L	H	Master	128fso	8k ~ 216kHz
6	H	H	L	Slave (Bypass)	Not used. Set to DVSS. (Note 15)	8k ~ 216kHz
7	H	H	H	Master (Bypass)	Not used. Set to DVSS.	8k ~ 216kHz

Note 15. Changed to TDMIN pin when PLL2-0 pins = “L/H/H”.

Table 3. Master/Slave Control (Output PORT)

Mode	ODIF1	ODIF0	SDTO Format
0	L	L	LSB justified
1	L	H	(Reserved)
2	H	L	MSB justified
3	H	H	I ² S Compatible

Table 4. Output Audio Interface Format 1 (Output PORT)

Mode	Master / Slave	OBIT1	OBIT0	SDTO	OLRCK	OBICK	OBICK Frequency	
							MSB justified, I ² S	LSB justified
0	Slave CMODE2-0 = “HLL” or “HHL”	L	L	16bit	Input	Input	≥ 32fso	64fso
1		L	H	18bit			≥ 36fso	
2		H	L	20bit			≥ 40fso	
3		H	H	24bit			≥ 48fso	
4	Master Except CMODE2-0 = “HLL” or “HHL”	L	L	16bit	Output	Output	64fso	
5		L	H	18bit				
6		H	L	20bit				
7		H	H	24bit				

Table 5. Output Audio Interface Format 2 (Output PORT)

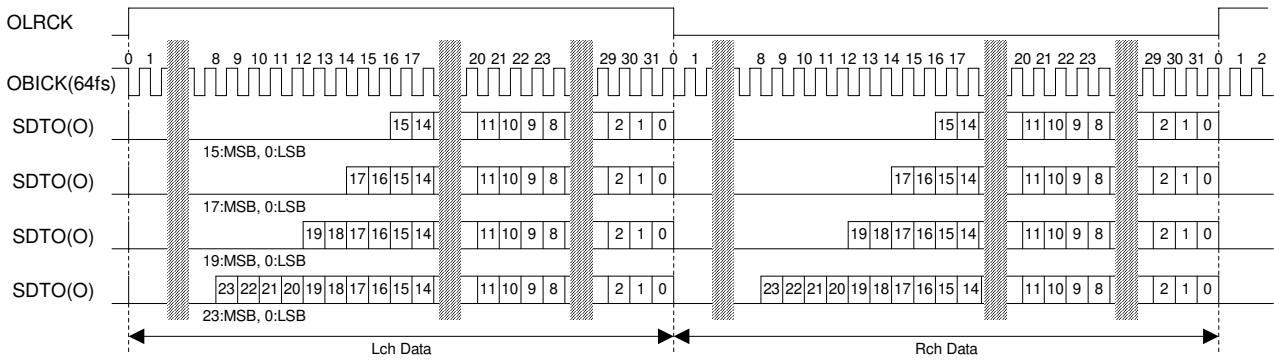

Figure 6. Normal Mode LSB Timing

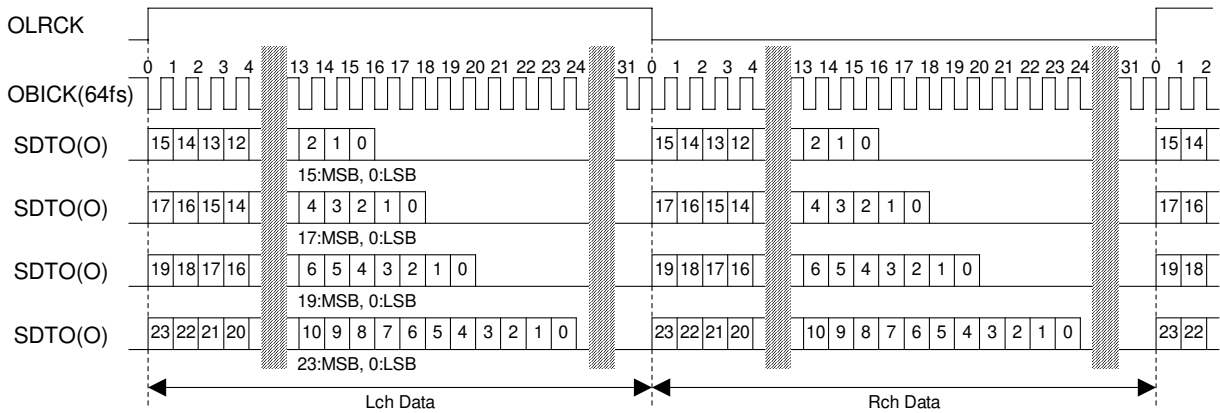

Figure 7. Normal Mode MSB Timing

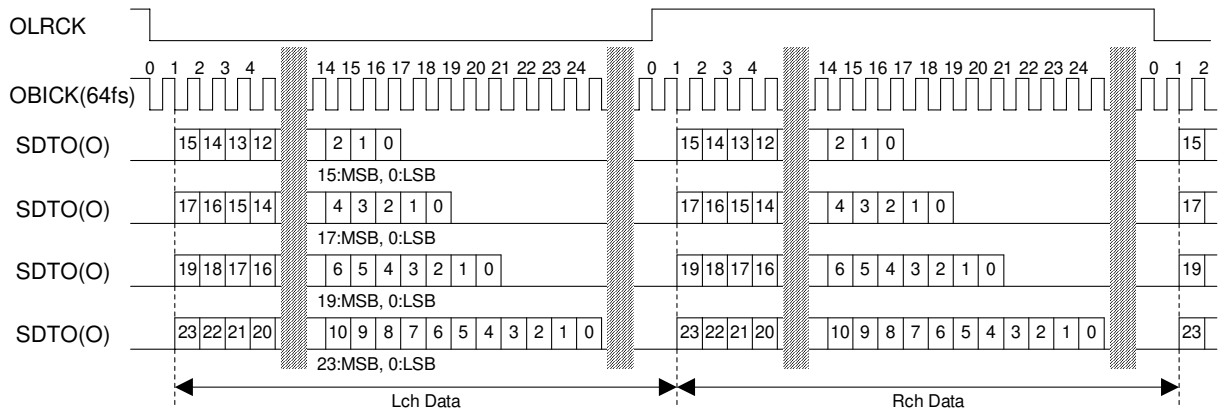

Figure 8. Normal Mode I²S Compatible Timing

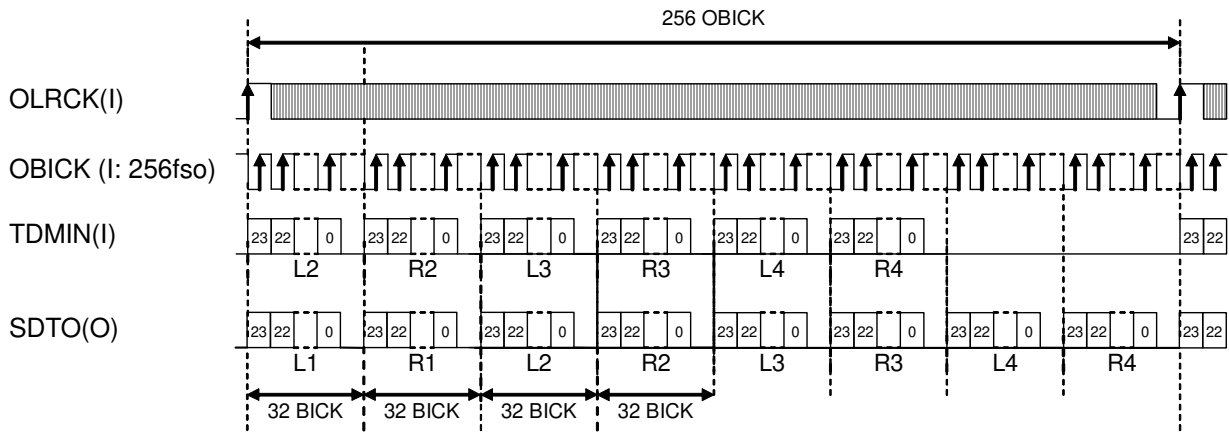

Figure 9. TDM mode MSB Timing

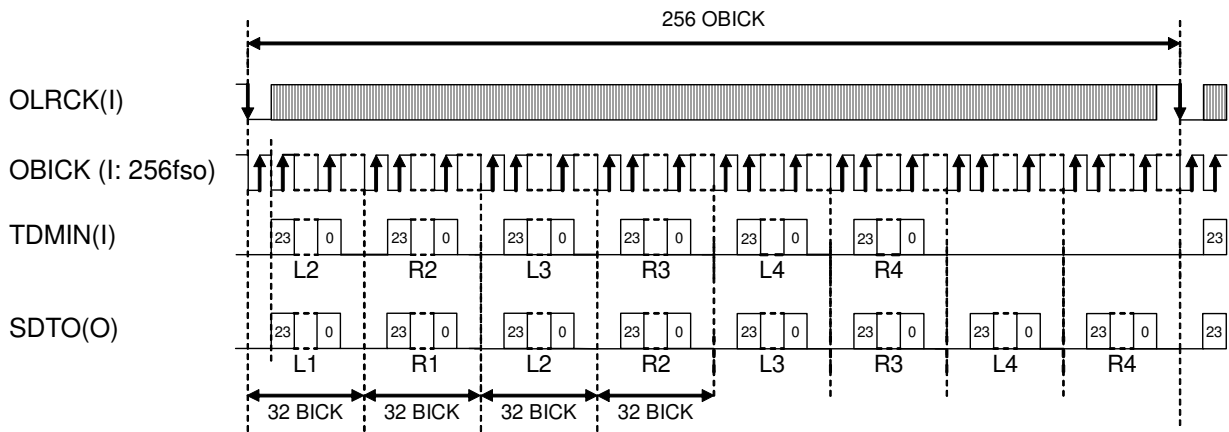

Figure 10. TDM mode I²S Compatible Timing

■ Cascade TDM Mode

The AK4127 supports cascading connection of up to four devices (8channels) in a daisy chain configuration at TDM mode. In this mode, the SDTO pin of device #N is connected to TDMIN pin of device #(N+1). The device can output up to 8ch TDM data multiplexed with TDMIN data. Figure 11 shows a connection example of a daisy chain.

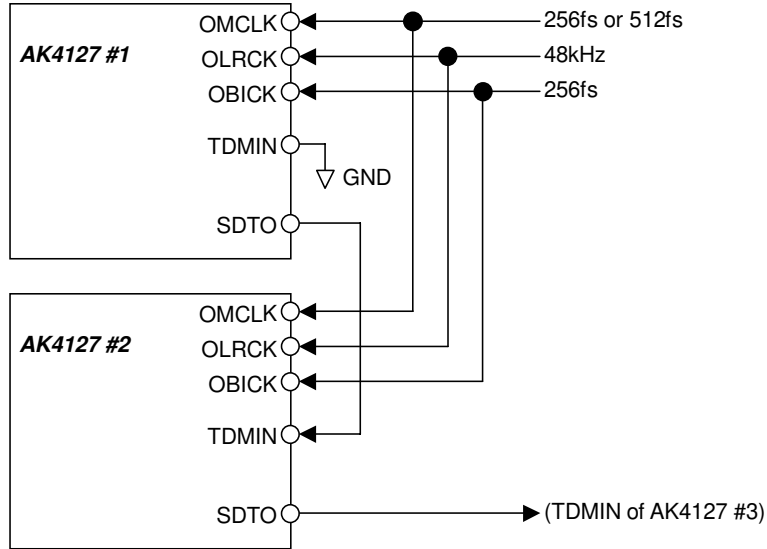

Figure 11. Cascade TDM Connection Diagram

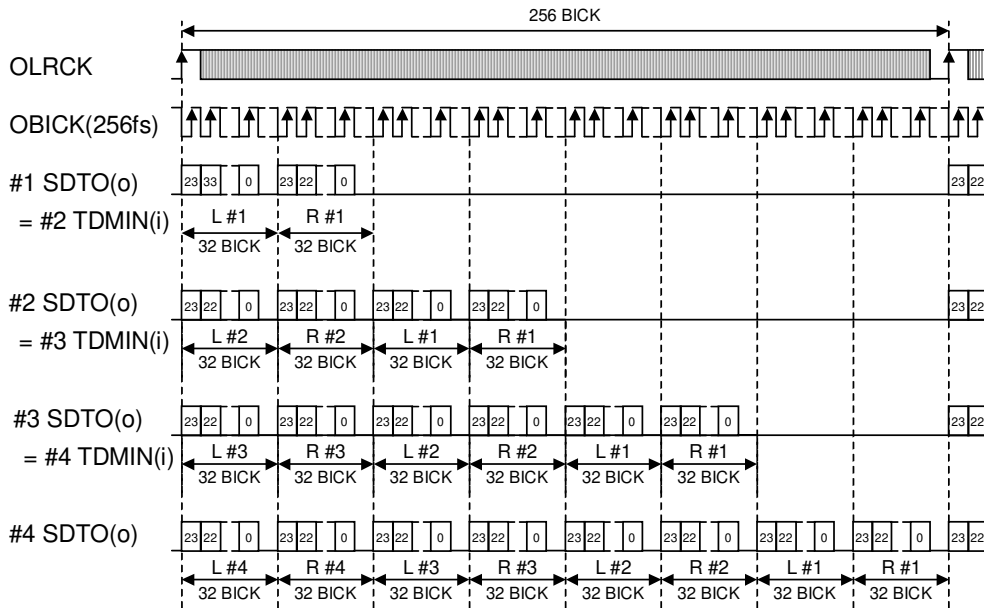

Figure 12. Cascade TDM Timing (4devices)

■ Soft Mute Operation

1. Manual mode

Soft mute operation is performed in the digital domain of the SRC output. Soft mute can be controlled by the SMUTE pin. When the SMUTE pin changes to “H”, the SRC output data is attenuated by $-\infty$ within 1024 OLRCK cycles. When the SMUTE pin changes to “L” the mute is cancelled and the output attenuation gradually changes to 0dB during 1024 OLRCK cycles. If the soft mute is cancelled before mute state after starting of the operation, the attenuation is discontinued and returned to 0dB by the same cycles. The soft mute is effective for changing the signal source.

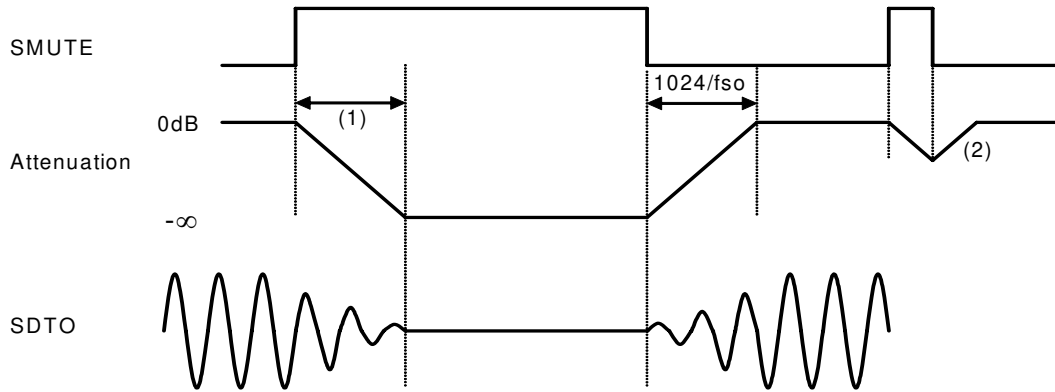

Figure 13. Soft Mute Function (Manual Mode)

- (1) The output data is attenuated by $-\infty$ during 1024 OLRCK cycles ($1024/f_{so}$).
- (2) If the soft mute is cancelled before attenuating to $-\infty$ after starting the operation, the attenuation is discontinued and returned to 0dB by the same number of clock cycles.

2. Semi-Auto mode

The soft mute is cancelled automatically by the setting of PLL2-0 pins (Table 2), after the AK4127 detects the rising edge (PDN pin = “L” → “H”) and the mute is continued during $4410/f_{so}=100ms@f_{so}=44.1kHz$. After PDN pin = “L” → “H” and when SMUTE pin is “H”, the mute is not cancelled.

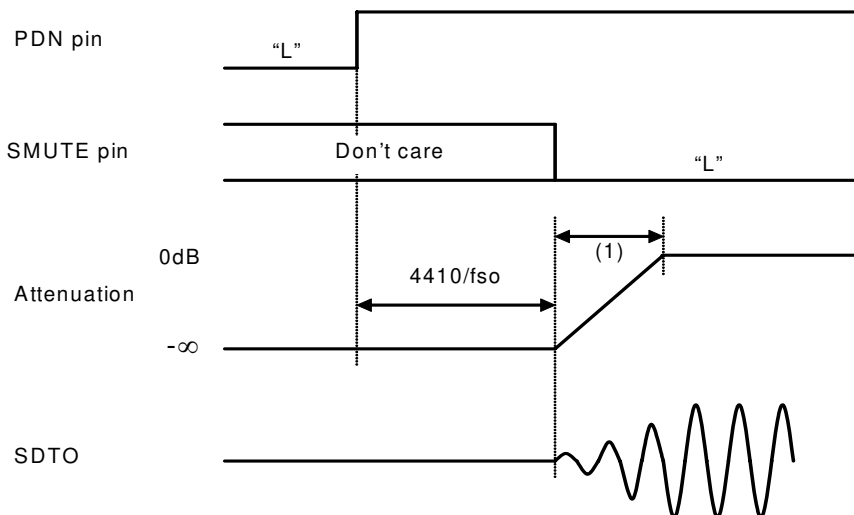

Figure 14. Soft Mute Function (Semi-Auto Mode)

- (1) The output data is returned to 0dB during 1024 OLRCK cycles ($1024/f_{so}$).

■ Dither

The AK4127 has a dither circuit. The dither circuit adds the dither to the LSB of the output data, which is the value of the OBIT1-0 pins, by DITHER pin = “H” regardless of the SRC mode or the SRC bypass mode.

■ System Reset

Bringing the PDN pin = “L” sets the AK4127 power-down mode and initializes the digital filter. The AK4127 should be reset once by bringing the PDN pin = “L” when power-up. When the PDN pin = “L”, the SDTO output is “L”. The SDTO valid time is 100ms. Until the output data becomes valid, the SDTO pin outputs “L”. The SDTO valid time is 100ms. Until the output data becomes valid, the SDTO pin outputs “L”.

Case 1

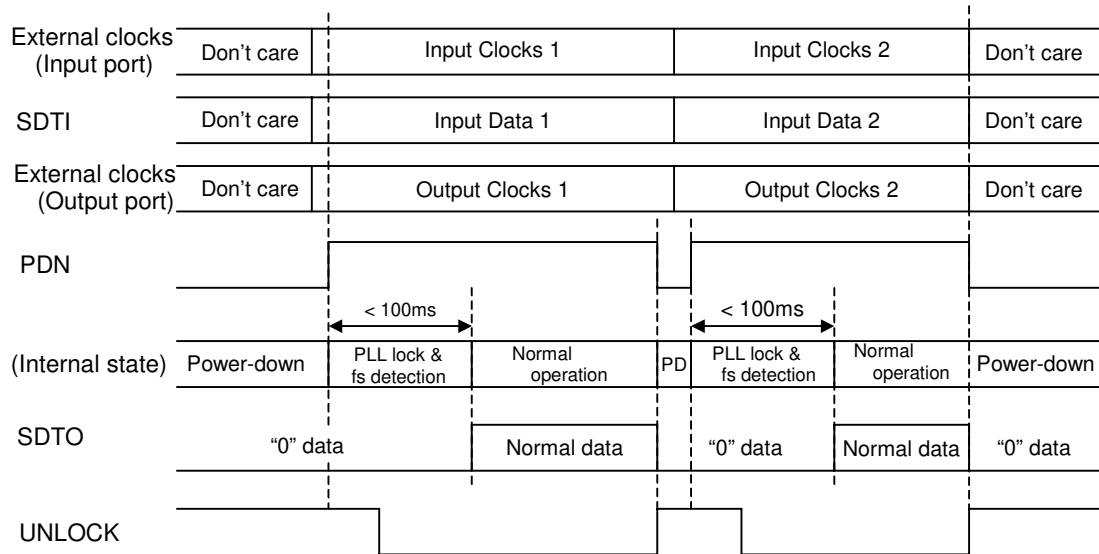

Figure 15. System Reset

Case 2

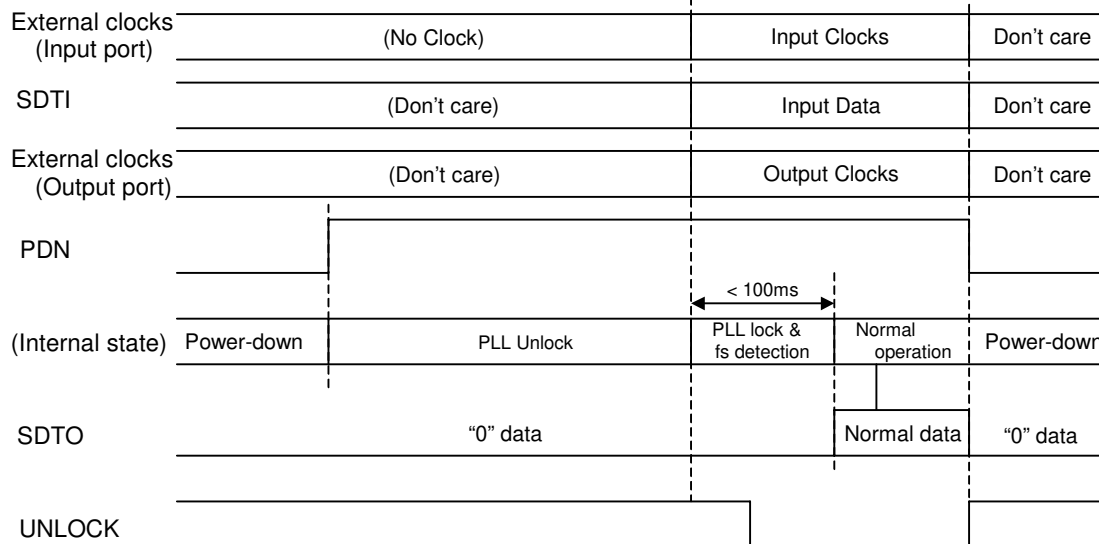

Figure 16. System Reset 2

■ Internal Reset Function for Clock Change

The AK4127 is reset automatically when the output clock is stopped. If the output clock is started again, normal data is output within 100ms.

■ Sequence of Changing Clocks

The change sequence of the clock supplied to AK4127 is shown in Figure 17.

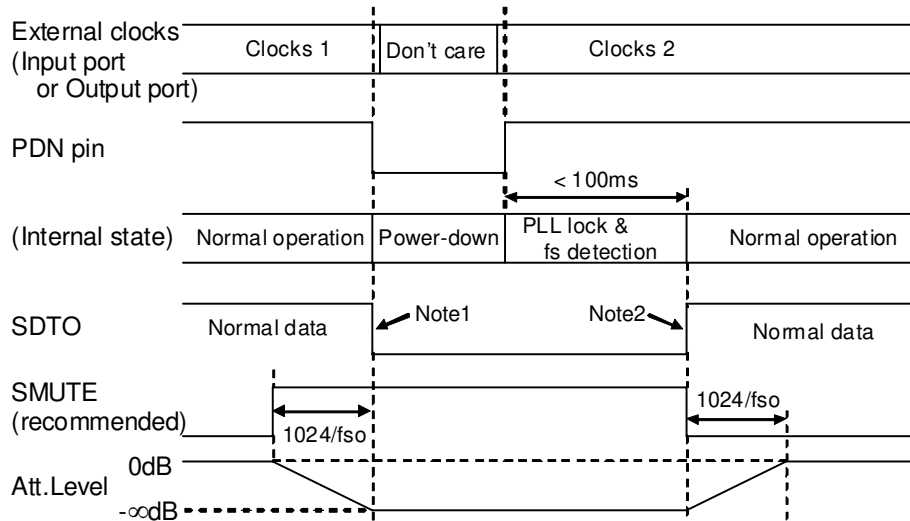

Figure 17. Sequence of Changing Clocks

Note 1. The data on SDTO may cause a clicking noise. To prevent this, set “0” to the SDTI from GD before the PDN pin changes to “L”. It makes the data on SDTO remain as “0”. SMUTE can also remove this clicking noise.

Note 2. The data on SDTO may cause a clicking noise. To prevent this, set SDTI to “0” for $1024/f_{so} + 100\text{ms}$ or more from the timing PDN pin changes to “H” while the SMUTE pin = “H”.

Note 3. When the PDN pin is not used for this clock change, a distorted signal may output for about 10ms ~ 100ms (typ) after changing clocks.

■ UNLOCK pin

The UNLOCK pin outputs “L” when the internal PLL is locked. When the internal PLL is unlocked, the UNLOCK pin outputs “H” and the SDTO = “0”. When the PDN pin = “L”, the UNLOCK pin outputs “H”.

■ PLL Loop Filter

The C1 and R should be connected in series and attached between the FILT pin and AVSS in parallel with C2. Please be careful the noise onto the FILT pin. When using IBICK, the value of external element is not dependent on the IBICK input frequency.

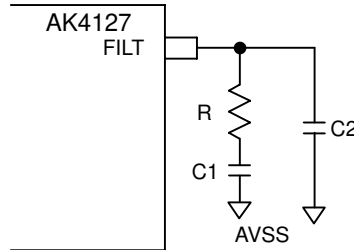

Figure 18. PLL Loop Filter

[Input PORT in slave mode]

1. When using ILRCK

PLL2	PLL1	PLL0	ILRCK	R [Ω]	C1 [μ F]	C2 [nF]
L	L	L	8k ~ 96kHz	$1.8k \pm 5\%$	$0.68 \pm 30\%$	$0.68 \pm 30\%$
L	L	H	8k ~ 216kHz	$1k \pm 5\%$	$1.0 \pm 30\%$	$2.2 \pm 30\%$
			16k ~ 216kHz	$1.5k \pm 5\%$	$0.68 \pm 30\%$	$0.68 \pm 30\%$
L	H	L	8k ~ 216kHz	$1k \pm 5\%$	$1.0 \pm 30\%$	$2.2 \pm 30\%$
			16k ~ 216kHz	$1.5k \pm 5\%$	$0.68 \pm 30\%$	$0.68 \pm 30\%$
L	H	H	8k ~ 216kHz	$1k \pm 5\%$	$1.0 \pm 30\%$	$2.2 \pm 30\%$
			16k ~ 216kHz	$1.5k \pm 5\%$	$0.68 \pm 30\%$	$0.68 \pm 30\%$

Table 6. PLL Loop Filter (ILRCK Mode)

- Note. Smaller value can be selected for the capacitors (C1, C2) in case of ILRCK range from 16kHz to 216kHz..

2. When using IBICK

PLL2	PLL1	PLL0	ILRCK	R [Ω]	C1 [μ F]	C2 [nF]
H	*	*	8k ~ 216kHz	$470 \pm 5\%$	$0.22 \pm 30\%$	$1.0 \pm 30\%$

Table 7. PLL Loop Filter (IBICK Mode, *: Don't care)

Note. The IBICK must be continuous except when the clocks are changed.

Note. IBICK = 32fsi is supported only 16bit LSB justified and I²S Compatible.

[Input PORT in master mode]

- When IMCLK is 256fs, 384fs, 512fs or 768fs, any external parts shown in [Figure 18](#) are not required.
- When IMCLK is 128fs or 192fs, the external parts shown in [Table 7](#) are required.

SYSTEM DESIGN

Figure 19 and Figure 20 show the system connection diagrams. The evaluation board demonstrates application circuits, the optimum layout, power supply arrangements and measurement results.

- Input PORT: Slave Mode, IBICK lock mode (64fsi), 24bit MSB justified
- Output PORT: Slave mode, 24bit MSB justified
- Dither = OFF

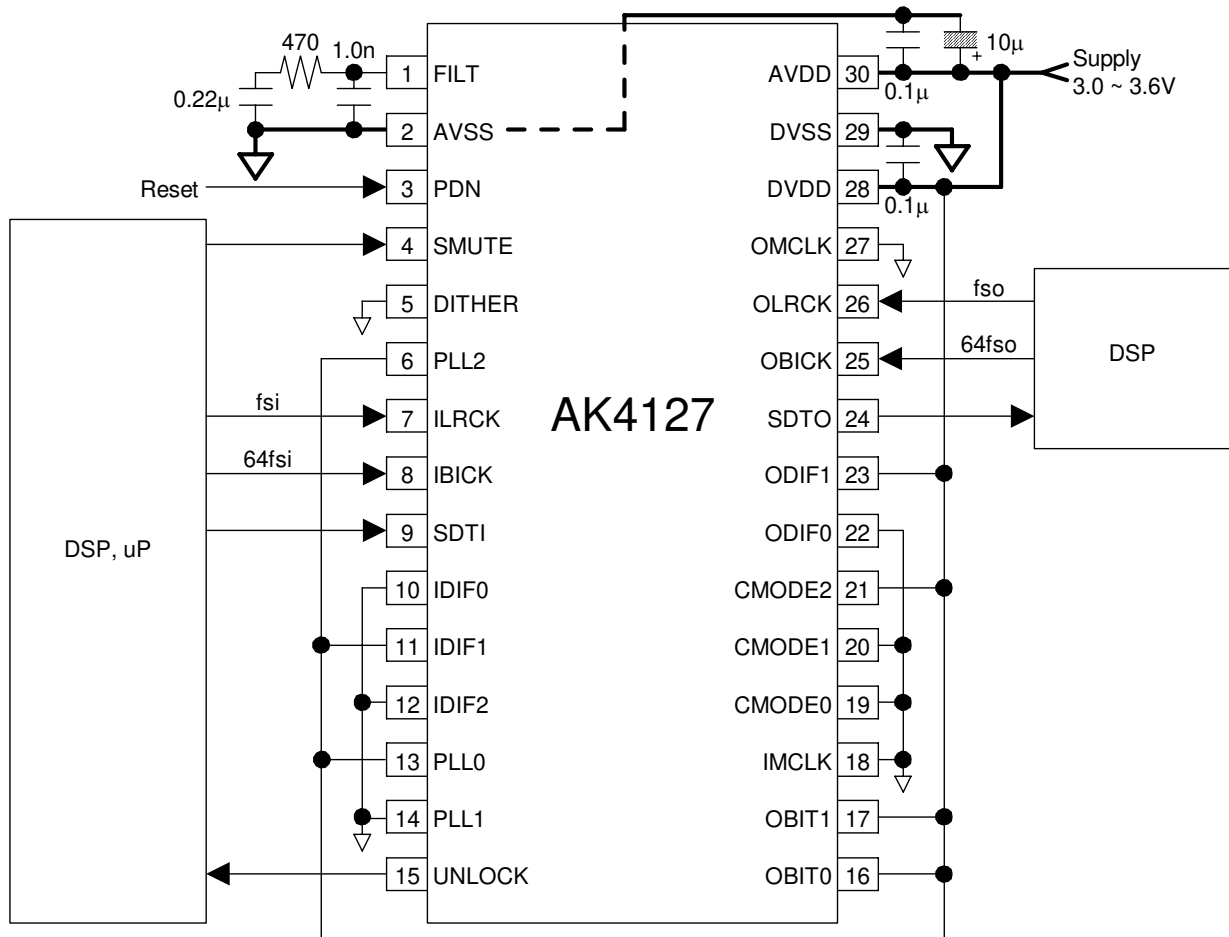

Note:

- AVSS and DVSS of the AK4127 must be distributed separately from the ground of external digital devices (MPU, DSP etc.).
- All digital input pins must not be left floating.

Figure 19. Typical Connection Diagram (Slave mode)

- Input PORT: Slave Mode, IBICK lock mode (64fsi), 24bit MSB justified
- Output PORT: Master mode, 24bit MSB justified
- Dither = OFF

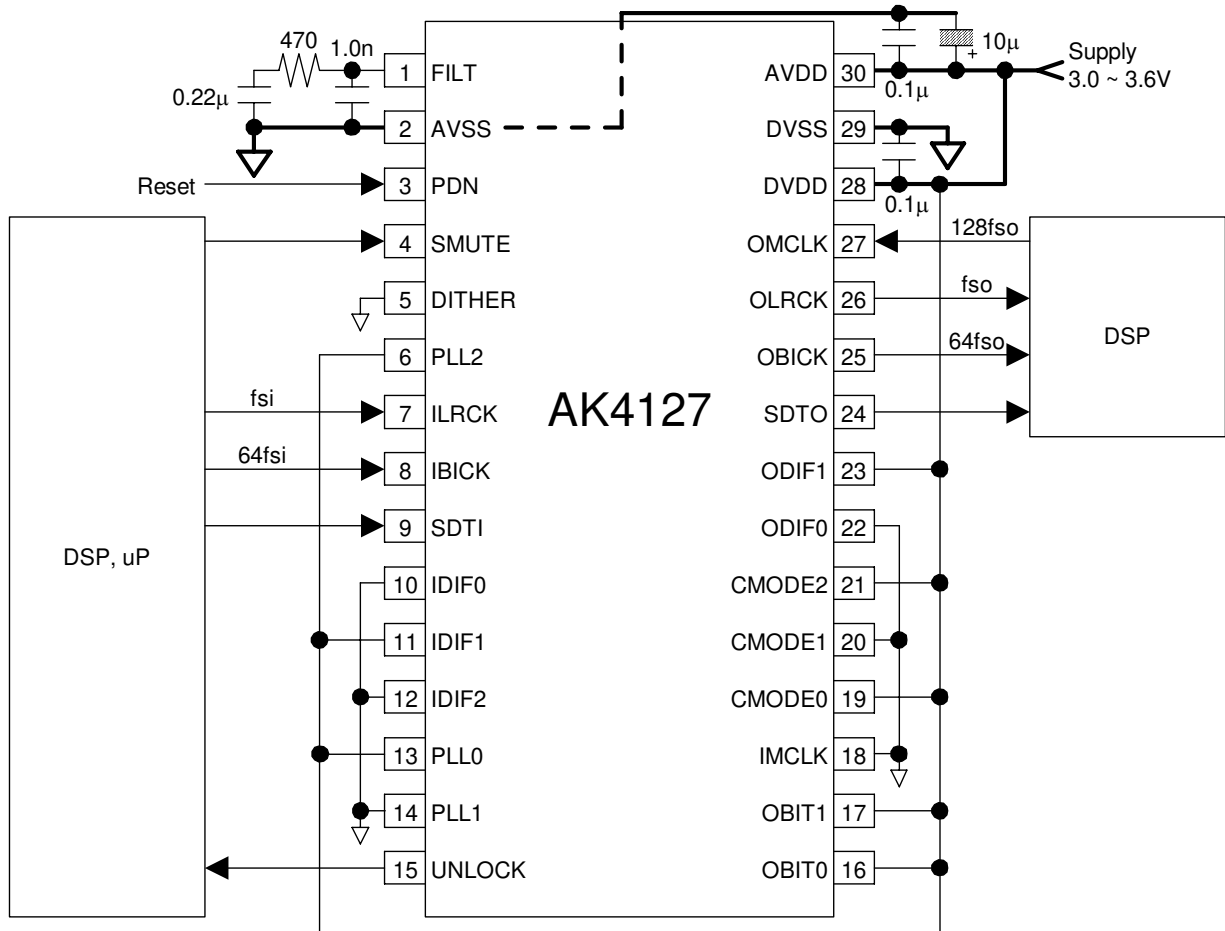

Note:

- AVSS and DVSS of the AK4127 must be distributed separately from the ground of external digital devices (MPU, DSP etc.).
- All digital input pins must not be left floating.

Figure 20. Typical Connection Diagram (Master mode)

1. Grounding and Power Supply Decoupling

The AK4127 requires careful attention to power supply and grounding arrangements. Alternatively if AVDD and DVDD are supplied separately, the power up sequence is not important. Decoupling capacitors should be as near to the AK4127 as possible, with the small value ceramic capacitor being the nearest.

2. Jitter Tolerance

Figure 21 shows the jitter tolerance to ILRCK and IBICK. The jitter quantity is defined by the jitter frequency and the jitter amplitude shown in Figure 21. When the jitter amplitude is 0.01U_{ipp} or less, the AK4127 operates normally regardless of the jitter frequency.

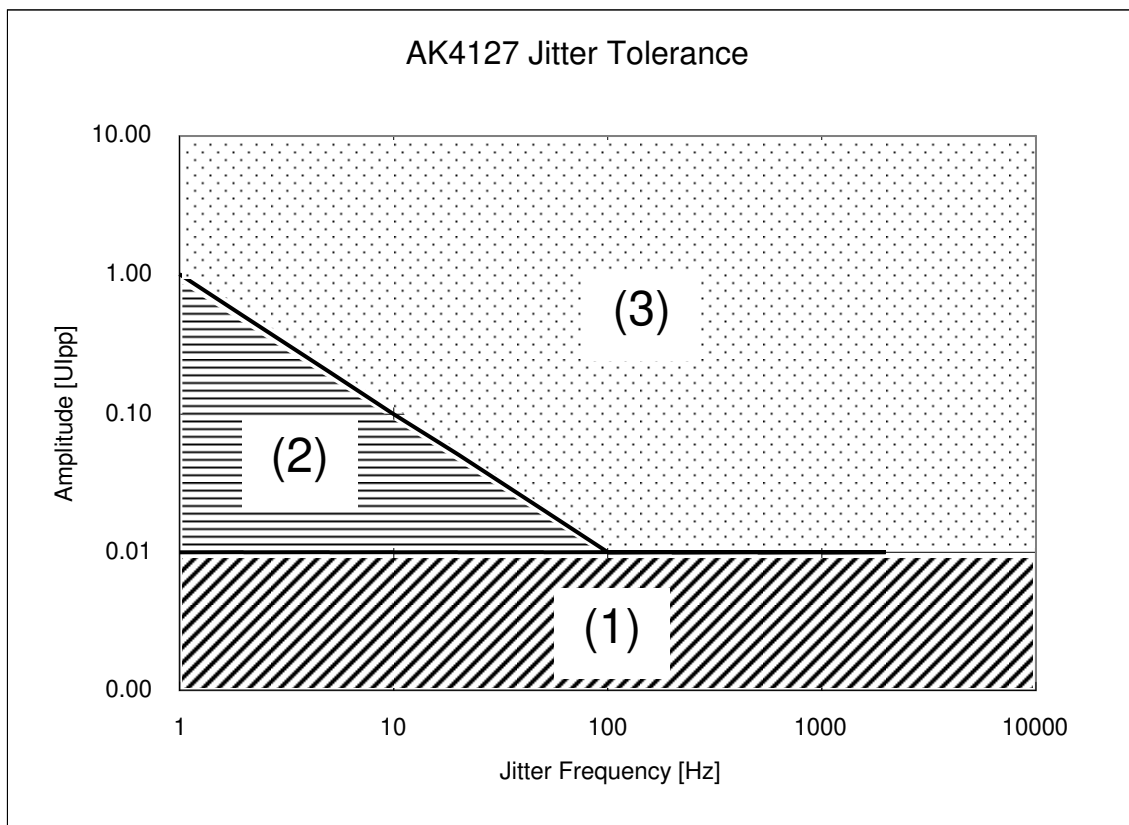

- (1) Normal operation
- (2) There is a possibility that the distortion degrades. (It may degrade up to about -50dB.)
- (3) There is a possibility that the output data is lost.

Note:

- When PLL2-0 = "L/*/*" (*: Don't care), the jitter amplitude is for ILRCK and 1UI (Unit Interval) is one cycle of ILRCK. When FSI = 48kHz, 1UI is 1/48kHz = 20.8μs.
- When PLL2-0 = "H/*/*" (*: Don't care), the jitter amplitude is for IBICK and 1UI (Unit Interval) is one cycle of IBICK. When FSI = 48kHz, 1UI is 1/(64 x 48kHz) = 326ns.

Figure 21. Jitter Tolerance

Tracking to the Input Sampling Frequency

When the ILRCK is generated by an external PLL, it may take time to settle after changing the input sampling frequency because the response of an external PLL to the frequency change is slow. The AK4127 operates normally up to 23%/sec speed but outputs incorrect data at the speed of the frequency change over 23%/sec.