



Chipsmall Limited consists of a professional team with an average of over 10 year of expertise in the distribution of electronic components. Based in Hongkong, we have already established firm and mutual-benefit business relationships with customers from,Europe,America and south Asia,supplying obsolete and hard-to-find components to meet their specific needs.

With the principle of “Quality Parts,Customers Priority,Honest Operation,and Considerate Service”,our business mainly focus on the distribution of electronic components. Line cards we deal with include Microchip,ALPS,ROHM,Xilinx,Pulse,ON,Everlight and Freescale. Main products comprise IC,Modules,Potentiometer,IC Socket,Relay,Connector.Our parts cover such applications as commercial,industrial, and automotives areas.

We are looking forward to setting up business relationship with you and hope to provide you with the best service and solution. Let us make a better world for our industry!



Contact us

Tel: +86-755-8981 8866 Fax: +86-755-8427 6832

Email & Skype: info@chipsmall.com Web: www.chipsmall.com

Address: A1208, Overseas Decoration Building, #122 Zhenhua RD., Futian, Shenzhen, China





AK4376

Low-Power Advanced 32-bit DAC with HP

1. General Description

The AK4376 is stereo advanced 32-bit high sound quality audio DAC with a built-in ground-referenced headphone amplifier. An internal circuit newly developed 32-bit digital filters for better sound quality, achieving low distortion characteristics and wide dynamic range. The sampling frequency supports up to 384 kHz. The AK4376 is available in a 36-pin CSP package, utilizing less board space than competitive offerings.

2. Features

1. Stereo High Sound Quality Low Power Advanced 32-bit DAC
 - 4 types of Digital Filter for Sound Color Selection
 - 2 types of Operation Mode (High Performance Mode / Low Power Mode)
2. Ground-referenced Class-G Stereo Headphone-Amp
 - Output Power: 25 mW @ 32Ω, THD+N < -60 dB
40 mW @ 16Ω, THD+N < -60 dB
 - THD+N: -106 dB
 - S/N: 125 dB
 - Output Noise Level: -125 dBV (Analog Volume ≤ -14 dB)
 - Analog Volume: +6 to -20 dB & Mute, 2 dB Step
 - Ground Loop Noise Cancellation
3. Digital Audio interface
 - Master/Slave mode
 - Sampling Frequency:
 - Slave Mode: 8 k, 11.025 k, 12 k, 16 k, 22.05 k, 24 k, 32 k, 44.1 k, 48 k, 64 k, 88.2 k, 96 k, 128 k, 176.4 k, 192 kHz, 256 k, 352.8 k, 384 kHz
 - Master Mode: 8 k, 11.025 k, 12 k, 16 k, 22.05 k, 24 k, 32 k, 44.1 k, 48 k, 64 k, 88.2 k, 96 k, 176.4 k, 192 kHz
 - Interface Format: 32/24/16-bit I²S/MSB justified
4. Power Management
5. PLL
6. X'tal Oscillator
7. μP I/F: I²C (400 kHz)
8. Ta = -40 to 85°C
9. Power Supply:
 - AVDD (DAC, PLL): 1.7 to 1.9 V
 - CVDD (HP-Amp, Charge Pump): 1.7 to 1.9 V
 - LVDD (LDO2 for Digital Core): 1.7 to 1.9 V (built-in LDO)
 - TVDD (Audio I/F): 1.65 to 3.6 V
10. Package: 36-pin CSP (2.74 x 2.56 mm, 0.4 mm pitch)

3. Block Diagram and Functions

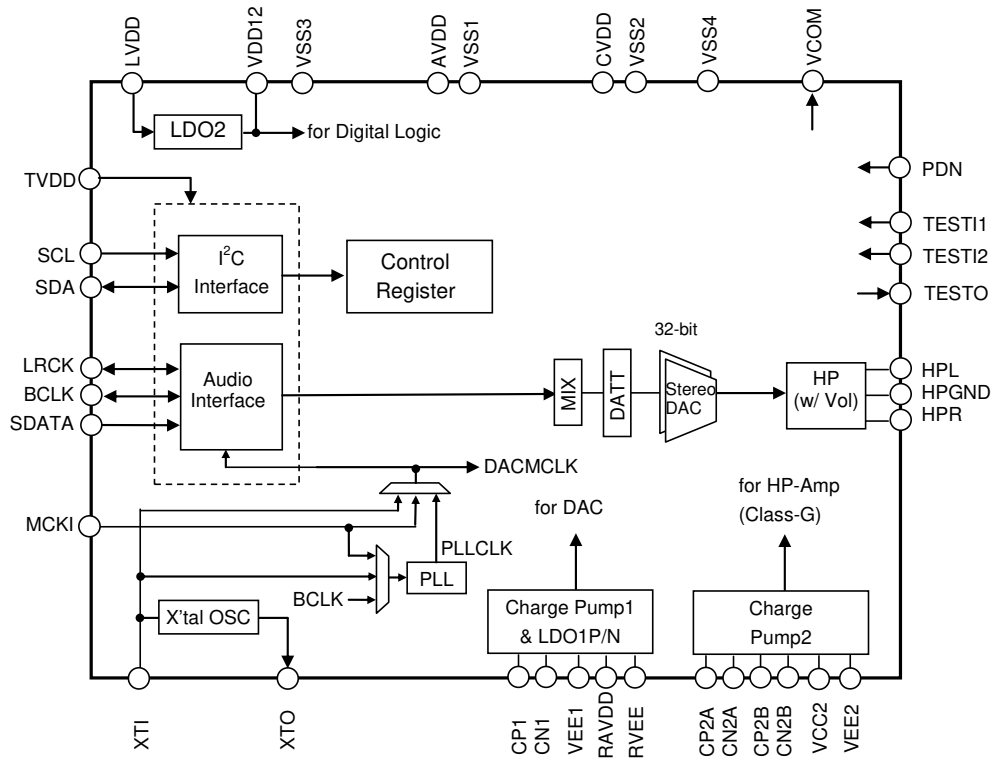
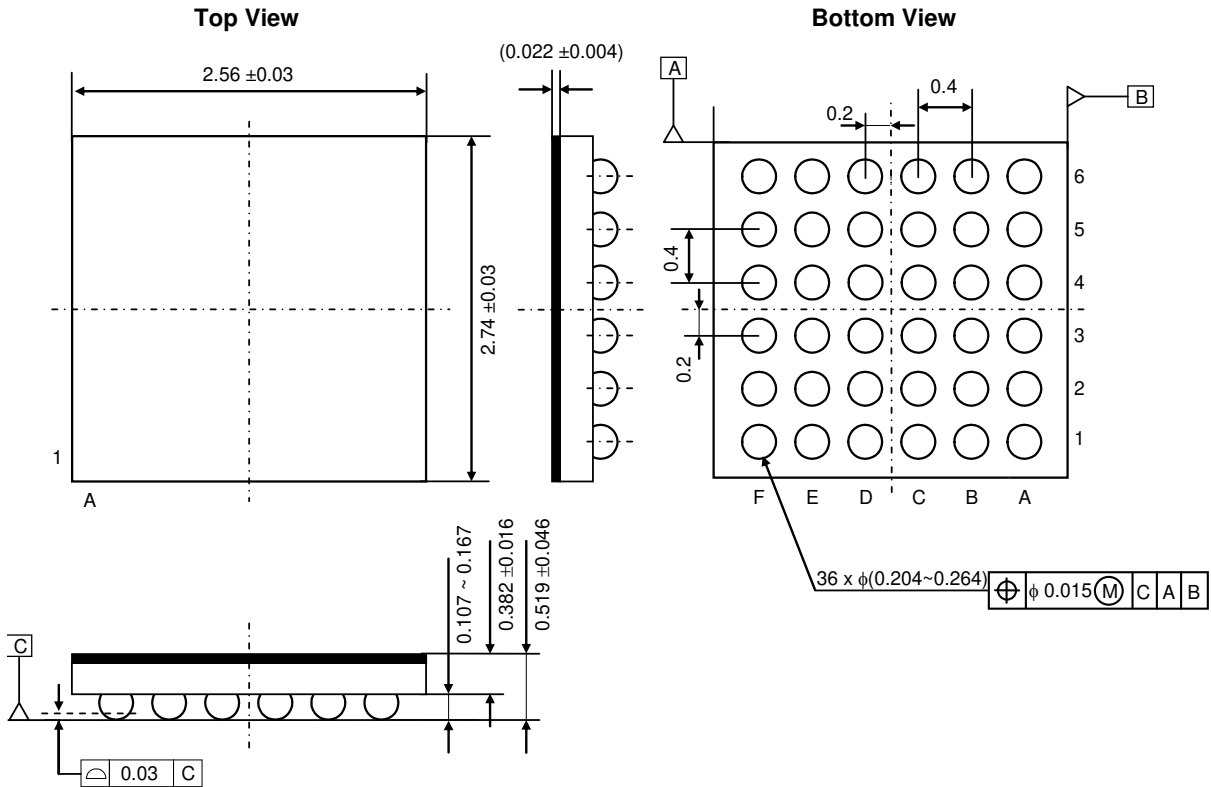

Figure 1. Block Diagram

4. Package

■ **Outline Dimensions**

36-pin CSP (Unit: mm)



■ **Material and Lead Finish**

Package molding compound: Epoxy Resin, Halogen (Br, Cl) Free
 Lead frame material: SnAgCuNi

■ **Marking**

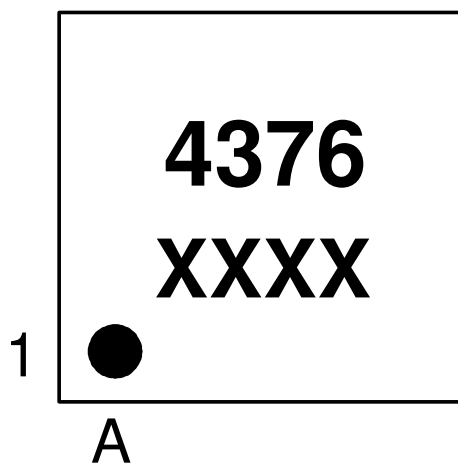

XXXX: Date code (4 digits)
Pin #A1 indication

5. Ordering Guide

AK4376ECB -40 to 85 °C 36-pin CSP (0.4 mm pitch)
AKD4376 Evaluation board for AK4376

6. Revision History

Date (Y/M/D)	Revision	Reason	Page	Contents
15/11/27	00	First Edition		

Thank you for your access to AKM products information.
More detail product information is available, please contact our sales
office or authorized distributors.

IMPORTANT NOTICE

0. Asahi Kasei Microdevices Corporation ("AKM") reserves the right to make changes to the information contained in this document without notice. When you consider any use or application of AKM product stipulated in this document ("Product"), please make inquiries the sales office of AKM or authorized distributors as to current status of the Products.
1. All information included in this document are provided only to illustrate the operation and application examples of AKM Products. AKM neither makes warranties or representations with respect to the accuracy or completeness of the information contained in this document nor grants any license to any intellectual property rights or any other rights of AKM or any third party with respect to the information in this document. You are fully responsible for use of such information contained in this document in your product design or applications. AKM ASSUMES NO LIABILITY FOR ANY LOSSES INCURRED BY YOU OR THIRD PARTIES ARISING FROM THE USE OF SUCH INFORMATION IN YOUR PRODUCT DESIGN OR APPLICATIONS.
2. The Product is neither intended nor warranted for use in equipment or systems that require extraordinarily high levels of quality and/or reliability and/or a malfunction or failure of which may cause loss of human life, bodily injury, serious property damage or serious public impact, including but not limited to, equipment used in nuclear facilities, equipment used in the aerospace industry, medical equipment, equipment used for automobiles, trains, ships and other transportation, traffic signaling equipment, equipment used to control combustions or explosions, safety devices, elevators and escalators, devices related to electric power, and equipment used in finance-related fields. Do not use Product for the above use unless specifically agreed by AKM in writing.
3. Though AKM works continually to improve the Product's quality and reliability, you are responsible for complying with safety standards and for providing adequate designs and safeguards for your hardware, software and systems which minimize risk and avoid situations in which a malfunction or failure of the Product could cause loss of human life, bodily injury or damage to property, including data loss or corruption.
4. Do not use or otherwise make available the Product or related technology or any information contained in this document for any military purposes, including without limitation, for the design, development, use, stockpiling or manufacturing of nuclear, chemical, or biological weapons or missile technology products (mass destruction weapons). When exporting the Products or related technology or any information contained in this document, you should comply with the applicable export control laws and regulations and follow the procedures required by such laws and regulations. The Products and related technology may not be used for or incorporated into any products or systems whose manufacture, use, or sale is prohibited under any applicable domestic or foreign laws or regulations.
5. Please contact AKM sales representative for details as to environmental matters such as the RoHS compatibility of the Product. Please use the Product in compliance with all applicable laws and regulations that regulate the inclusion or use of controlled substances, including without limitation, the EU RoHS Directive. AKM assumes no liability for damages or losses occurring as a result of noncompliance with applicable laws and regulations.
6. Resale of the Product with provisions different from the statement and/or technical features set forth in this document shall immediately void any warranty granted by AKM for the Product and shall not create or extend in any manner whatsoever, any liability of AKM.
7. This document may not be reproduced or duplicated, in any form, in whole or in part, without prior written consent of AKM.