



Chipsmall Limited consists of a professional team with an average of over 10 year of expertise in the distribution of electronic components. Based in Hongkong, we have already established firm and mutual-benefit business relationships with customers from,Europe,America and south Asia,supplying obsolete and hard-to-find components to meet their specific needs.

With the principle of “Quality Parts,Customers Priority,Honest Operation,and Considerate Service”,our business mainly focus on the distribution of electronic components. Line cards we deal with include Microchip,ALPS,ROHM,Xilinx,Pulse,ON,Everlight and Freescale. Main products comprise IC,Modules,Potentiometer,IC Socket,Relay,Connector.Our parts cover such applications as commercial,industrial, and automotives areas.

We are looking forward to setting up business relationship with you and hope to provide you with the best service and solution. Let us make a better world for our industry!



Contact us

Tel: +86-755-8981 8866 Fax: +86-755-8427 6832

Email & Skype: info@chipsmall.com Web: www.chipsmall.com

Address: A1208, Overseas Decoration Building, #122 Zhenhua RD., Futian, Shenzhen, China





AK4393

Advanced Multi-Bit 96kHz 24-Bit $\Delta\Sigma$ DAC

GENERAL DESCRIPTION

The AK4393 is a high performance stereo DAC for the 96kHz sampling mode of DAT, DVD including a 24bit digital filter. The AK4393 introduces the advanced multi-bit system for $\Delta\Sigma$ modulator. This new architecture achieves the wider dynamic range, while keeping much the same superior distortion characteristics as conventional Single-Bit way. In the AK4393, the analog outputs are filtered in the analog domain by switched-capacitor filter (SCF) with high tolerance to clock jitter. The analog outputs are full differential output, so the device is suitable for hi-end applications. The operating voltages support analog 5V and digital 3.3V, so it is easy to I/F with 3.3V logic IC.

FEATURES

- 128x Oversampling
- Sampling Rate up to 108kHz
- 24Bit 8x Digital Filter
Ripple: $\pm 0.005\text{dB}$, Attenuation: 75dB
- High Tolerance to Clock Jitter
- Low Distortion Differential Output
- Digital de-emphasis for 32, 44.1, 48 & 96kHz sampling
- Soft Mute
- THD+N: -100dB
- DR, S/N: 120dB
- I/F format : MSB justified, 16/20/24bit LSB justified, I^2S
- Master Clock: Normal Speed: 256fs, 384fs, 512fs or 768fs
Double Speed: 128fs, 192fs, 256fs or 384fs
- Power Supply: 4.75 to 5.25V (Analog), 3 to 5.25V (Digital)
- Small Package: 28pin VSOP

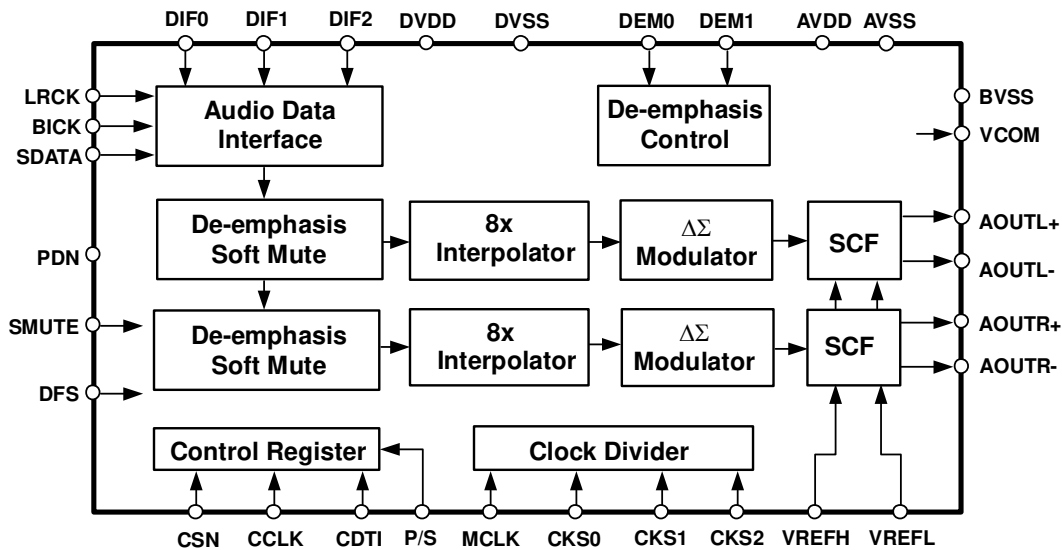

■ Ordering Guide

AK4393VF -40 ~ +85 °C 28pin VSOP (0.65mm pitch)
 AKD4393 Evaluation Board

■ Pin Layout

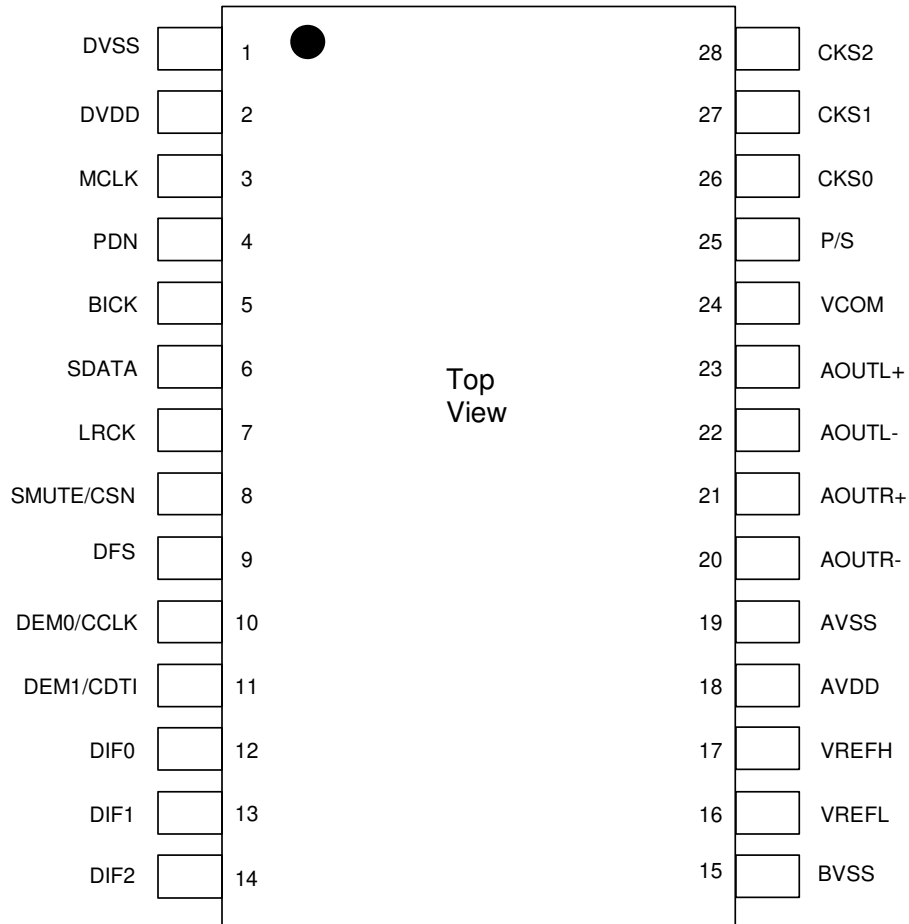

PIN/FUNCTION			
No.	Pin Name	I/O	Function
1	DVSS	-	Digital Ground Pin
2	DVDD	-	Digital Power Supply Pin, 3.3V or 5.0V
3	MCLK	I	Master Clock Input Pin
4	PDN	I	Power-Down Mode Pin When at "L", the AK4393 is in power-down mode and is held in reset. The AK4393 should always be reset upon power-up.
5	BICK	I	Audio Serial Data Clock Pin The clock of 64fs or more than is recommended to be input on this pin.
6	SDATA	I	Audio Serial Data Input Pin 2's complement MSB-first data is input on this pin.
7	LRCK	I	L/R Clock Pin
8	SMUTE	I	Soft Mute Pin in parallel mode When this pin goes "H", soft mute cycle is initiated. When returning "L", the output mute releases.
	CSN	I	Chip Select Pin in serial mode
9	DFS	I	Double Speed Sampling Mode Pin (Internal pull-down pin) "L": Normal Speed, "H": Double Speed
10	DEM0	I	De-emphasis Enable Pin in parallel mode
	CCLK	I	Control Data Clock Pin in serial mode
11	DEM1	I	De-emphasis Enable Pin in parallel mode
	CDTI	I	Control Data Input Pin in serial mode
12	DIF0	I	Digital Input Format Pin
13	DIF1	I	Digital Input Format Pin
14	DIF2	I	Digital Input Format Pin
15	BVSS	-	Substrate Ground Pin, 0V
16	VREFL	I	Low Level Voltage Reference Input Pin
17	VREFH	I	High Level Voltage Reference Input Pin
18	AVDD	-	Analog Power Supply Pin, 5.0V
19	AVSS	-	Analog Ground Pin, 0V
20	AOUTR-	O	Rch Negative analog output Pin
21	AOUTR+	O	Rch Positive analog output Pin
22	AOUTL-	O	Lch Negative analog output Pin
23	AOUTL+	O	Lch Positive analog output Pin
24	VCOM	O	Common Voltage Output Pin, 2.6V
25	P/S	I	Parallel/Serial Select Pin (Internal pull-up pin) "L": Serial control mode, "H": Parallel control mode
26	CKS0	I	Master Clock Select Pin
27	CKS1	I	Master Clock Select Pin
28	CKS2	I	Master Clock Select Pin

Note: All input pins except internal pull-up/down pins should not be left floating.

ABSOLUTE MAXIMUM RATINGS

(AVSS, BVSS, DVSS = 0V; Note 1)

Parameter		Symbol	min	max	Units
Power Supplies:	Analog	AVDD	-0.3	6.0	V
	Digital	DVDD	-0.3	6.0	V
	BVSS-DVSS (Note 2)	Δ GND	-	0.3	V
Input Current , Any pin Except Supplies		IIN	-	\pm 10	mA
Input Voltage		VIND	-0.3	DVDD+0.3	V
Ambient Operating Temperature		Ta	-40	85	°C
Storage Temperature		Tstg	-65	150	°C

Notes: 1. All voltages with respect to ground.

2. AVSS, BVSS and DVSS must be connected to the same analog ground plane.

WARNING: Operation at or beyond these limits may result in permanent damage to the device.

Normal operation is not guaranteed at these extremes.

RECOMMENDED OPERATING CONDITIONS

(AVSS, BVSS, DVSS=0V; Note 1)

Parameter		Symbol	min	typ	max	Units
Power Supplies: (Note 3)	Analog	AVDD	4.75	5.0	5.25	V
	Digital	DVDD	3.0	3.3	5.25	V
Voltage Reference (Note 4)	“H” voltage reference	VREFH	AVDD-0.5	-	AVDD	V
	“L” voltage reference	VREFL	AVSS	-	-	V
	VREFH-VREFL	Δ VREF	3.0	-	AVDD	V

Notes: 3. The power up sequence between AVDD and DVDD is not critical.

4. Analog output voltage scales with the voltage of (VREFH-VREFL).

$$AOUT(\text{typ.}@0\text{dB}) = (AOUT+) - (AOUT-) = \pm 2.4V_{pp} \times (VREFH - VREFL) / 5.$$

* AKM assumes no responsibility for the usage beyond the conditions in this data sheet.

ANALOG CHARACTERISTICS

(Ta = 25°C; AVDD = 5V, DVDD = 3.3V; AVSS, BVSS, DVSS = 0V, VREFH = AVDD, VREFL = AVSS;
 fs = 44.1kHz; BICK = 64fs; Signal Frequency = 1kHz; 24bit Input Data; Measurement Bandwidth = 20Hz~20kHz;
 RL ≥ 600Ω; External circuit: Figure 11; unless otherwise specified)

Parameter	min	typ	max	Units	
Resolution			24	Bits	
Dynamic Characteristics (Note 5)					
THD+N	fs=44.1kHz	0dBFS	-100	-90	dB
	BW=20kHz	-60dBFS	-53	-	dB
	fs=96kHz	0dBFS	-97	-86	dB
	BW=40kHz	-60dBFS	-51	-	dB
Dynamic Range (-60dBFS with A-weighted)	fs=44.1kHz (Note 6)	112	117		dB
	(Note 7)	-	120		dB
	fs=96kHz	111	116		dB
	(Note 7)	-	118		dB
S/N (A-weighted)	fs=44.1kHz (Note 8)	112	117		dB
	(Note 7)	-	120		dB
	fs=96kHz	111	116		dB
	(Note 7)	-	118		dB
Interchannel Isolation (1kHz)	100	120		dB	
DC Accuracy					
Interchannel Gain Mismatch		0.15	0.3	dB	
Gain Drift (Note 9)		20	-	ppm/°C	
Output Voltage (Note 10)	±2.25	±2.4	±2.55	Vpp	
Load Resistance (Note 11)	600			Ω	
Output Current			3.5	mA	
Power Supplies					
Power Supply Current					
Normal Operation (PDN = "H")	AVDD		60	-	mA
	DVDD(fs=44.1kHz)		3	-	mA
	DVDD(fs=96kHz)		5	-	mA
	AVDD + DVDD			90	mA
	Power-Down Mode (PDN = "L")				
AVDD + DVDD (Note 12)		10	50	μA	
Power Supply Rejection (Note 13)		50		dB	

Notes: 5. At 44.1kHz, measured by Audio Precision, System Two. Averaging mode.

At 96kHz, measured by ROHDE & SCHWARZ, UPD. Averaging mode.

Refer to the eva board manual.

6. 101dB at 16bit data and 116dB at 20bit data.

7. By Figure12. External LPF Circuit Example 2.

8. S/N does not depend on input bit length.

9. The voltage on (VREFH-VREFL) is held +5V externally.

10. Full-scale voltage (0dB). Output voltage scales with the voltage of (VREFH-VREFL).

AOOUT (typ.@0dB) = (AOOUT+) - (AOOUT-) = ±2.4Vpp×(VREFH-VREFL)/5.

11. For AC-load. 1kΩ for DC-load.

12. In the power-down mode. P/S = DVDD, and all other digital input pins including clock pins (MCLK, BICK and LRCK) are held DVSS.

13. PSR is applied to AVDD, DVDD with 1kHz, 100mVpp. VREFH pin is held +5V.

FILTER CHARACTERISTICS (fs = 44.1kHz)

(Ta = 25°C; AVDD = 4.75~5.25V; DVDD = 3.0~5.25V; fs = 44.1kHz; Normal Speed Mode; DEM = OFF)

Parameter	Symbol	min	typ	max	Units
Digital Filter					
Passband	±0.01dB (Note 14) -6.0dB	PB	0	22.05	20.0
			-		-
Stopband	(Note 14)	SB	24.1		kHz
Passband Ripple		PR		± 0.005	dB
Stopband Attenuation		SA	75		dB
Group Delay	(Note 15)	GD	-	28	1/fs
Digital Filter + SCF					
Frequency Response	0 ~ 20.0kHz		-	± 0.2	dB

Note: 14. The passband and stopband frequencies scale with fs.

For example, PB = 0.4535×fs (@±0.01dB), SB = 0.546×fs.

15. The calculating delay time which occurred by digital filtering. This time is from setting the 16/20/24bit data of both channels to input register to the output of analog signal.

FILTER CHARACTERISTICS (fs = 96kHz)

(Ta = 25°C; AVDD = 4.75~5.25V; DVDD = 3.0~5.25V; fs = 96kHz; Double Speed Mode; DEM = OFF)

Parameter	Symbol	min	typ	max	Units
Digital Filter					
Passband	±0.01dB (Note 14) -6.0dB	PB	0	48.0	43.5
			-		-
Stopband	(Note 14)	SB	52.5		kHz
Passband Ripple		PR		± 0.005	dB
Stopband Attenuation		SA	75		dB
Group Delay	(Note 15)	GD	-	28	1/fs
Digital Filter + SCF					
Frequency Response	0 ~ 40.0kHz		-	± 0.3	dB

DC CHARACTERISTICS

(Ta = 25°C; AVDD = 4.75~5.25V; DVDD = 3.0~5.25V)

Parameter	Symbol	min	typ	max	Units
High-Level Input Voltage	VIH	70%DVDD	-	-	V
Low-Level Input Voltage	VIL	-	-	30%DVDD	V
Input Leakage Current	Iin	-	-	± 10	µA

Note: 16. DFS and P/S pins have internal pull-down or pull-up devices, nominally 100kΩ.

SWITCHING CHARACTERISTICS

(Ta = 25°C; AVDD = 4.75~5.25V; DVDD = 3.0~5.25V; CL = 20pF)

Parameter	Symbol	min	typ	max	Units
Master Clock Timing (Note 17)					
Normal Speed: 256fs, Double Speed: 128fs	fCLK	7.7		13.824	MHz
Pulse Width Low	tCLKL	28			ns
Pulse Width High	tCLKH	28			ns
Normal Speed: 384fs, Double Speed: 192fs	fCLK	11.5		20.736	MHz
Pulse Width Low	tCLKL	20			ns
Pulse Width High	tCLKH	20			ns
Normal Speed: 512fs, Double Speed: 256fs	fCLK	15.4		27.648	MHz
Normal Speed: 768fs, Double Speed: 384fs	fCLK	23.0		41.472	MHz
Pulse Width Low	tCLKL	7			ns
Pulse Width High	tCLKH	7			ns
LRCK Frequency (Note 18)					
Normal Speed Mode (DFS = "L")	fsn	30	44.1	54	kHz
Double Speed Mode (DFS = "H")	fsd	60	88.2	108	kHz
Duty Cycle	Duty	45		55	%
Serial Interface Timing					
BICK Period	tBCK	140			ns
BICK Pulse Width Low	tBCKL	60			ns
Pulse Width High	tBCKH	60			ns
BICK "↑" to LRCK Edge (Note 19)	tBLR	20			ns
LRCK Edge to BICK "↑" (Note 19)	tLRB	20			ns
SDATA Hold Time	tSDH	20			ns
SDATA Setup Time	tSDS	20			ns
Control Interface Timing					
CCLK Period	tCCK	200			ns
CCLK Pulse Width Low	tCCKL	80			ns
Pulse Width High	tCCKH	80			ns
CDTI Setup Time	tCDS	50			ns
CDTI Hold Time	tCDH	50			ns
CSN High Time	tCSW	150			ns
CSN "↓" to CCLK "↑"	tCSS	50			ns
CCLK "↑" to CSN "↑"	tCSH	50			ns
Reset Timing					
PDN Pulse Width (Note 20)	tPW	150			ns

Notes: 17. For Double Speed mode please see Appendix A for relationship of MCLK and BCLK/LRCK.

18. When the normal and double speed modes are switched, AK4393 should be reset by PDN pin or RSTN bit.

19. BICK rising edge must not occur at the same time as LRCK edge.

20. The AK4393 can be reset by bringing PDN "L" to "H".

When the states of CKS2-0 or DFS change, the AK4393 should be reset by PDN pin or RSTN bit.

■ Timing Diagram

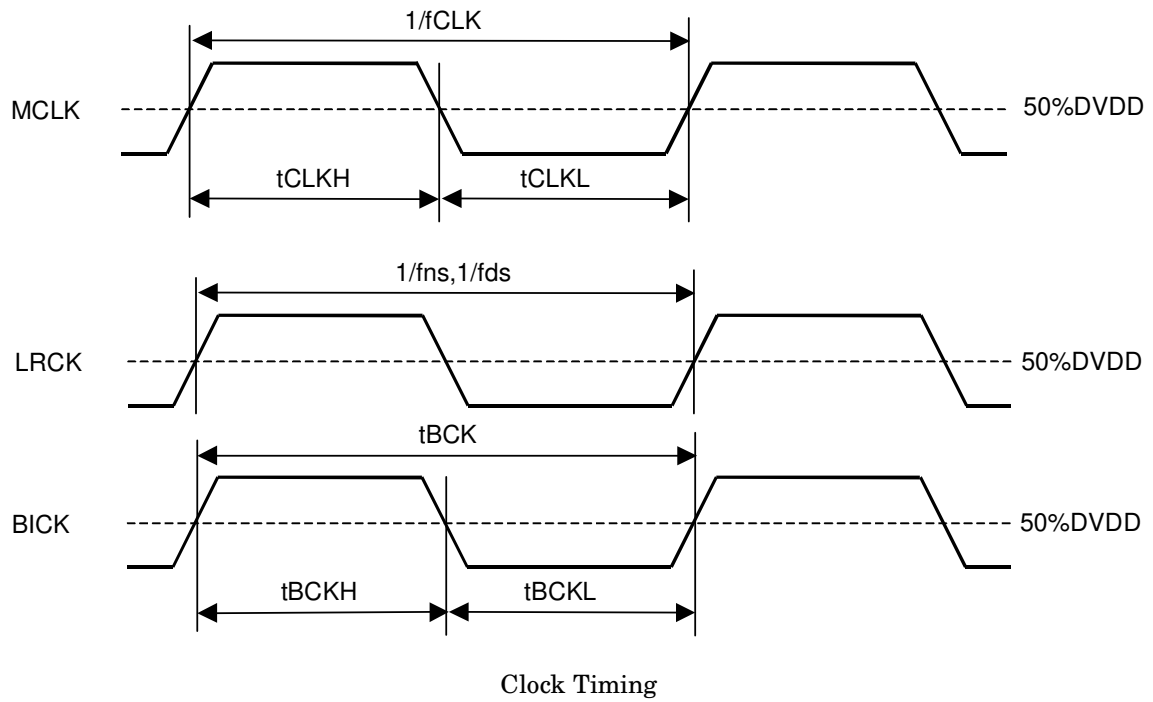

For Double Speed mode timing please see Appendix A for relationship of MCLK and BCLK/LRCK.

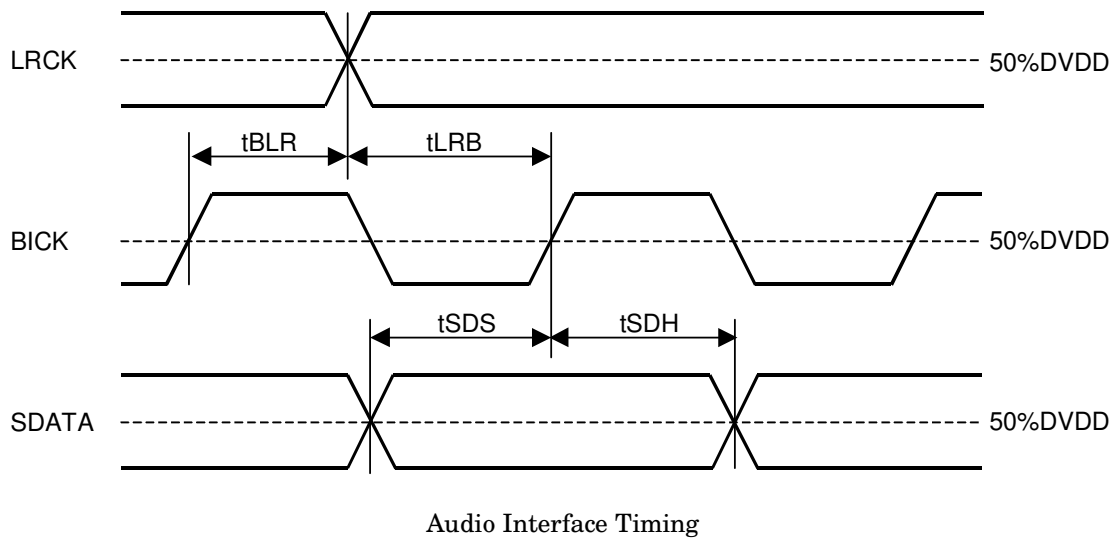

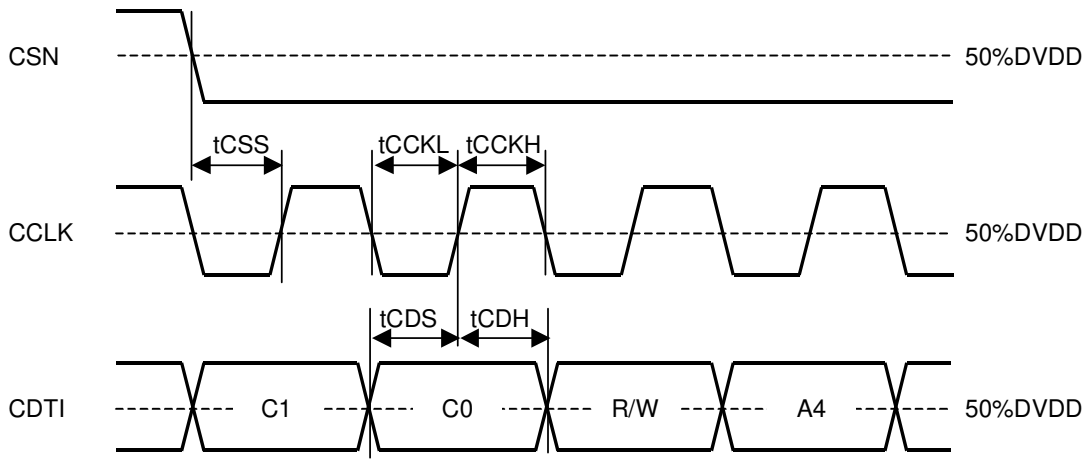

WRITE Command Input Timing

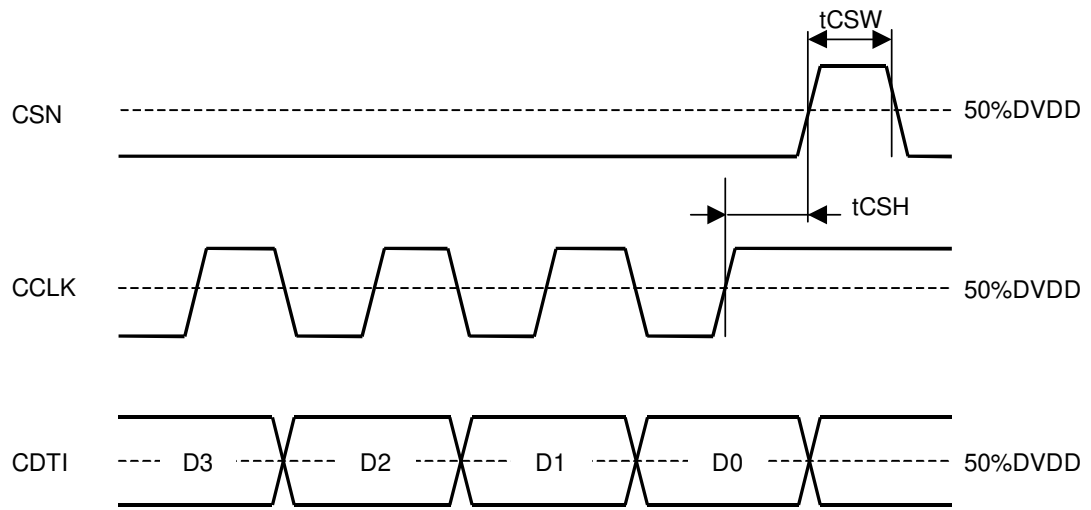

WRITE Data Input Timing

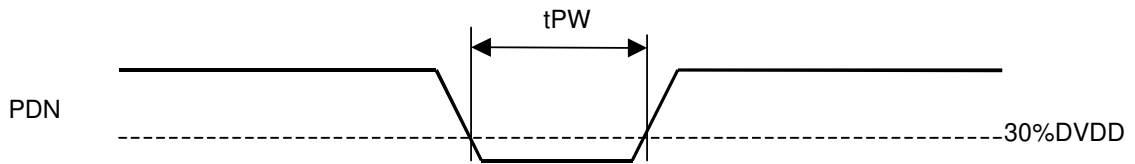

Power-down Timing

OPERATION OVERVIEW

■ **System Clock**

The external clocks, which are required to operate the AK4393, are MCLK, LRCK and BICK. The master clock (MCLK) should be synchronized with LRCK but the phase is not critical. **However, in Double Speed Mode, the phase relationship between MCLK and LRCK/BICK is limited. (Refer to Appendix A).** The MCLK is used to operate the digital interpolation filter and the delta-sigma modulator. The sampling speed is set by DFS (Table 1). The sampling rate (LRCK), CKS0/1/2 and DFS determine the frequency of MCLK (Table 2).

All external clocks (MCLK, BICK and LRCK) should always be present whenever the AK4393 is in normal operation mode (PDN = "H"). If these clocks are not provided, the AK4393 may draw excess current because the device utilizes dynamic refreshed logic internally. If the external clocks are not present, the AK4393 should be in the power-down mode (PDN = "L") or in the reset mode (RSTN = "0"). After exiting reset at power-up etc., the AK4393 is in power-down mode until MCLK and LRCK are input.

DFS	Sampling Rate (fs)		Default
0	Normal Speed Mode	30kHz~54kHz	
1	Double Speed Mode	60kHz~108kHz	

Table 1. Sampling Speed

Mode	CKS2	CKS1	CKS0	Normal	Double	Default
0	0	0	0	256fs	128fs	
1	0	0	1	256fs	256fs	
2	0	1	0	384fs	192fs	
3	0	1	1	384fs	384fs	
4	1	0	0	512fs	256fs	
5	1	0	1	512fs	N/A	
6	1	1	0	768fs	384fs	
7	1	1	1	768fs	N/A	

Table 2. System Clocks

LRCK fs	MCLK				BICK 64fs
	256fs	384fs	512fs	768fs	
32.0kHz	8.1920MHz	12.2880MHz	16.3840MHz	24.5760MHz	2.0480MHz
44.1kHz	11.2896MHz	16.9344MHz	22.5792MHz	33.8688MHz	2.8224MHz
48.0kHz	12.2880MHz	18.4320MHz	24.5760MHz	36.8640MHz	3.0720MHz

Table 3. System clock example (Normal Speed Mode)

LRCK fs	MCLK				BICK 64fs
	128fs	192fs	256fs	384fs	
88.2kHz	11.2896MHz	16.9344MHz	22.5792MHz	33.8688MHz	5.6448MHz
96.0kHz	12.2880MHz	18.4320MHz	24.5760MHz	36.8640MHz	6.1440MHz

Table 4. System clock example (Double Speed Mode)

■ Audio Serial Interface Format

Data is shifted in via the SDATA pin using BICK and LRCK inputs. Five data formats are supported and selected by the DIF0-2 as shown in Table 5. In all formats the serial data is MSB-first, 2's compliment format and is latched on the rising edge of BICK. Mode 2 can be used for 20 and 16 MSB justified formats by zeroing the unused LSBs.

Mode	DIF2	DIF1	DIF0	Mode	BICK	Figure
0	0	0	0	0: 16bit LSB Justified	≥32fs	Figure 1
1	0	0	1	1: 20bit LSB Justified	≥40fs	Figure 2
2	0	1	0	2: 24bit MSB Justified	≥48fs	Figure 3
3	0	1	1	3: I ² S Compatible	≥48fs	Figure 4
4	1	0	0	4: 24bit LSB Justified	≥48fs	Figure 2

Table 5. Audio Data Formats

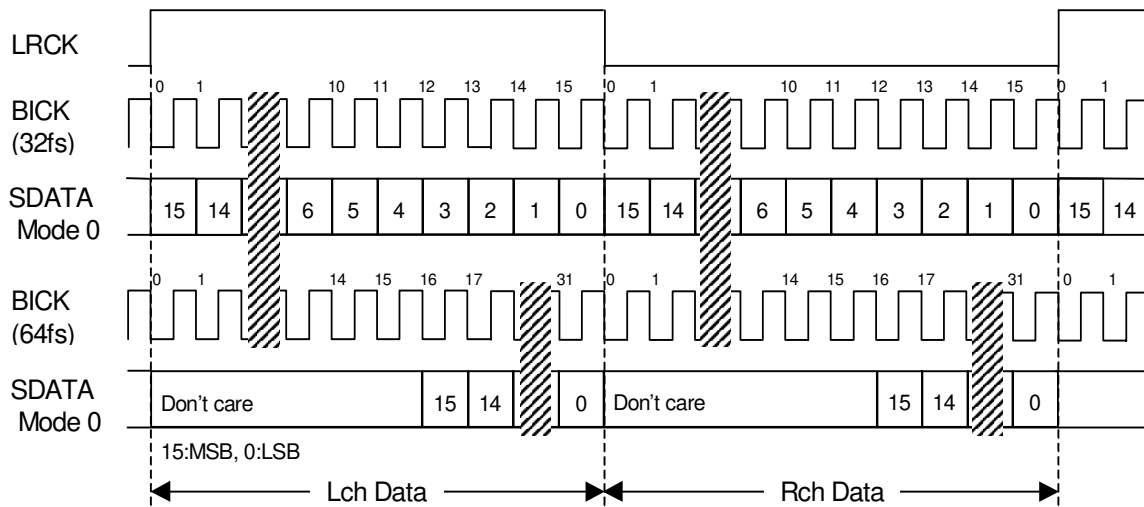

Figure 1. Mode 0 Timing

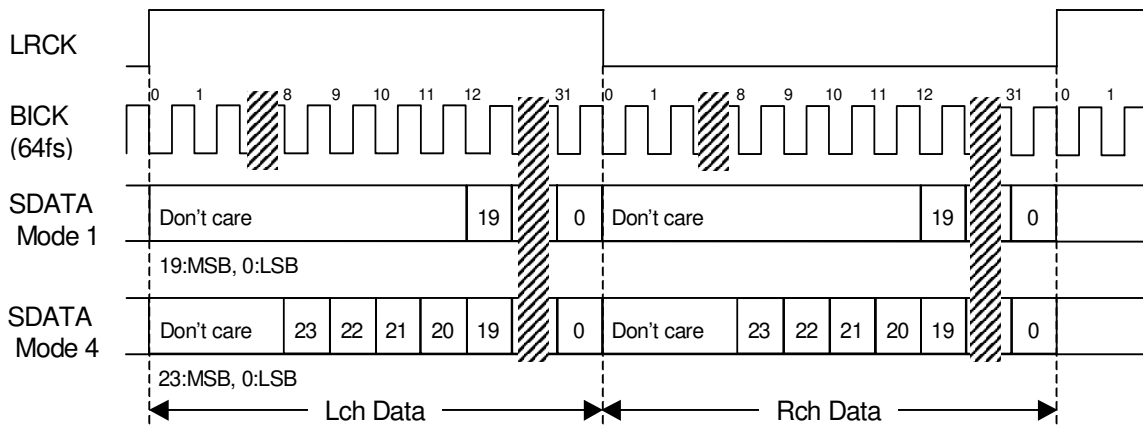

Figure 2. Mode 1,4 Timing

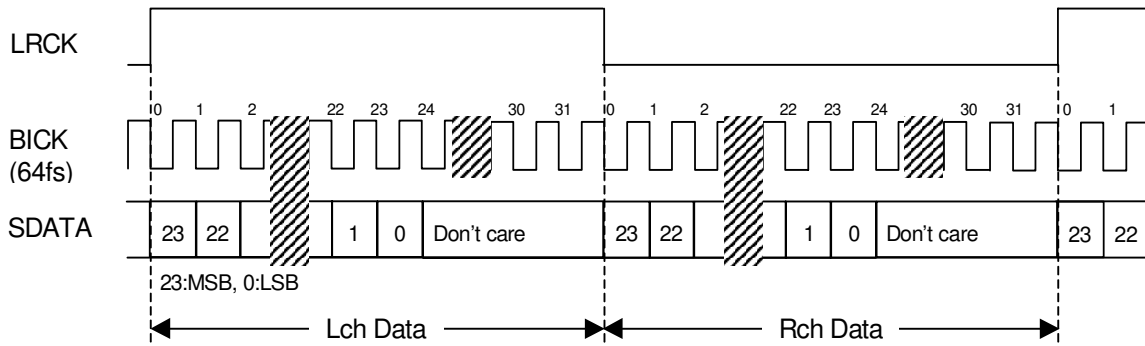

Figure 3. Mode 2 Timing

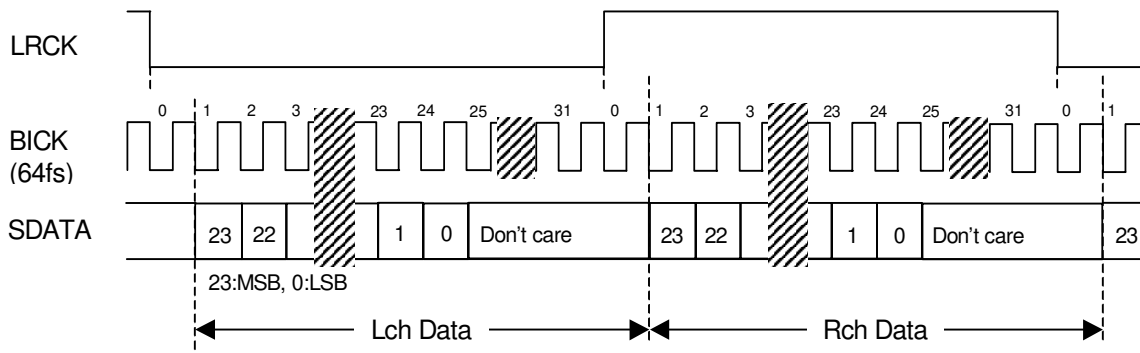

Figure 4. Mode 3 Timing

■ De-emphasis filter

A digital de-emphasis filter is available for 32, 44.1, 48 or 96kHz sampling rates ($t_c = 50/15\mu s$) and is enabled or disabled with the DEM0, DEM1 and DFS input pins.

DEM1	DEM0	DFS	Mode
0	0	0	44.1kHz
0	1	0	OFF
1	0	0	48kHz
1	1	0	32kHz
0	0	1	OFF
0	1	1	OFF
1	0	1	96kHz
1	1	1	OFF

Default

Table 6. De-emphasis filter control

■ Soft mute operation

Soft mute operation is performed at digital domain. When SMUTE goes to “H”, the output signal is attenuated by $-\infty$ during 1024 LRCK cycles. When SMUTE is returned to “L”, the mute is cancelled and the output attenuation gradually changes to 0dB during 1024 LRCK cycles. If the soft mute is cancelled within 1024 LRCK cycles after starting the operation, the attenuation is discontinued and returned to 0dB. The soft mute is effective for changing the signal source without stopping the signal transmission.

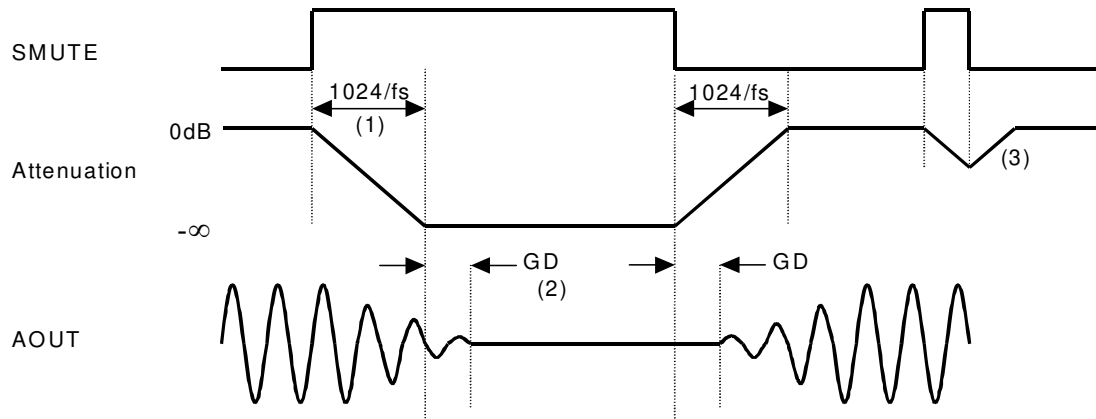

Notes:

- (1) The output signal is attenuated by $-\infty$ during 1024 LRCK cycles (1024/fs).
- (2) Analog output corresponding to digital input has the group delay (GD).
- (3) If the soft mute is cancelled within 1024 LRCK cycles, the attenuation is discontinued and returned to 0dB.

Figure 5. Soft mute operation

■ System Reset

The AK4393 should be reset once by bringing PDN = “L” upon power-up. The AK4393 is powered up and the internal timing starts clocking by LRCK “↑” after exiting reset and power down state by MCLK. The AK4393 is in the power-down mode until MCLK and LRCK are input.

■ Power-Down

The AK4393 is placed in the power-down mode by bringing PDN pin “L” and the analog outputs are floating (Hi-Z). Figure 6 shows an example of the system timing at the power-down and power-up.

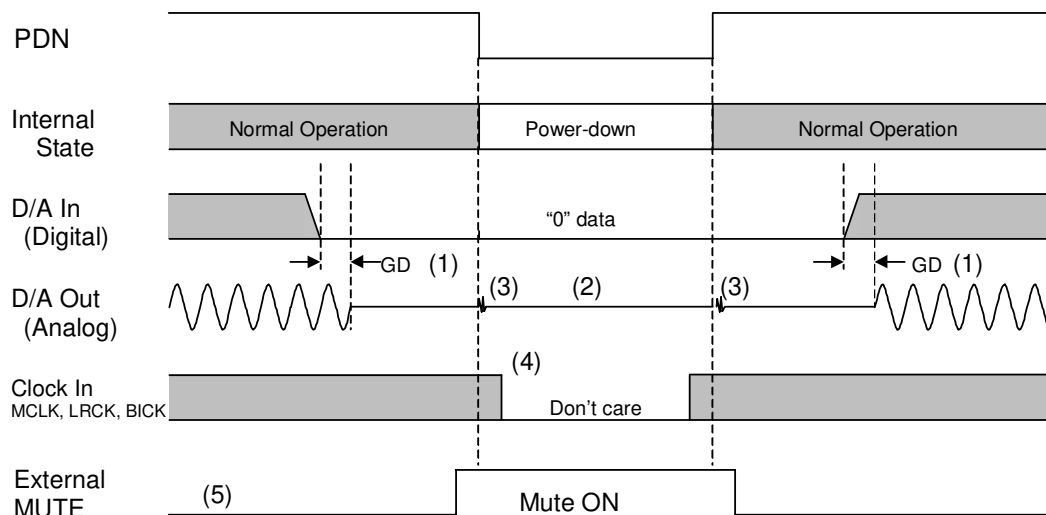

Notes:

- (1) The analog output corresponding to digital input has the group delay (GD).
- (2) Analog outputs are floating (Hi-Z) at the power-down mode.
- (3) Click noise occurs at the edge of PDN signal. This noise is output even if “0” data is input.
- (4) The external clocks (MCLK, BICK and LRCK) can be stopped in the power-down mode (PDN = “L”).
- (5) Please mute the analog output externally if the click noise (3) influences system application.
The timing example is shown in this figure.

Figure 6. Power-down/up sequence example

■ Click Noise from analog output

Click noise occurs from analog output in the following cases.

- 1) When switching de-emphasis mode by DEM0, DEM1 and DFS pins,
- 2) When switching serial data mode by DIF0, DIF1 and DIF2 pins,
- 3) When going and exiting power down mode by PDN pin,
- 4) When switching normal speed and double speed by DFS pin,

However in case of 1) & 2), If the input data is “0” or the soft mute is enabled (after 1024 LRCK cycles from SMUTE = “H”), no click noise occur except for switching DFS pin.

■ Mode Control Interface

Pins (parallel control mode) or registers (serial control mode) can control each functions of the AK4393. For DIF2-0, CKS2-0 and DFS, the setting of pin and register are “ORed” internally. So, even serial control mode, pin setting can also control these functions.

The serial control interface is enabled by the P/S pin = “L”. In this mode, pin setting must be all “L”. Internal registers may be written by 3-wire μP interface pins: CSN, CCLK and CDTI. The data on this interface consists of Chip address (2bits, C1/0; fixed to “01”), Read/Write (1bit; fixed to “1”), Register address (MSB first, 5bits) and Control data (MSB first, 8bits). The AK4393 latches the data on the rising edge of CCLK, so data should be clocked in on the falling edge. The writing of data becomes valid by CSN “↑”. The clock speed of CCLK is 5MHz(max). The CSN and CCLK must be fixed to “H” when the register does not be accessed.

PDN = “L” resets the registers to their default values. When the state of P/S pin is changed, the AK4393 should be reset by PDN = “L”. In serial mode, the internal timing circuit is reset by RSTN bit, but the registers are not initialized.

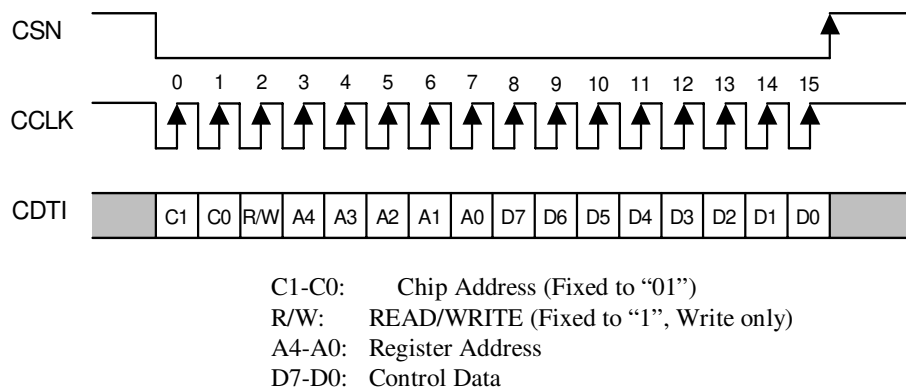

Figure 7. Control I/F Timing

- *The AK4393 does not support the read command and chip address. C1/0 and R/W are fixed to “011”
- *When the AK4393 is in the power down mode (PDN = “L”) or the MCLK is not provided, writing into the control register is inhibited.
- *For setting the registers, the following sequence is recommended.
 - Control 1 register
 - (1) Writing RSTN = “0” and other bits (D6-D1) to the register at the same time.
 - (2) Writing RSTN = “1” to the register. The other bits are no change.
 - Control 2 register

This writing sequence has no limitation like control 1 register.
- *When RSTN = “0”, the click noise is output from AOUT pins.
- *If the mode setting is done without setting RSTN = “0”, large noise may be output from AOUT pins. (Especially when CKS0/1/2 are changed.)

■ Register Map

Addr	Register Name	D7	D6	D5	D4	D3	D2	D1	D0
00H	Control 1	0	CKS2	CKS1	CKS0	DIF2	DIF1	DIF0	RSTN
01H	Control 2	0	0	0	0	DFS	DEM1	DEM0	SMUTE
02H	Test	TEST7	TEST6	TEST5	TEST4	TEST3	TEST2	TEST1	TEST0

Notes:

For addresses from 03H to 1FH, data must not be written.

When PDN pin goes to “L”, the registers are initialized to their default values. When RSTN bit goes to “0”, the only internal timing is reset and the registers are not initialized to their default values. DIF2-0, CKS2-0 and DFS bits are ORed with pins respectively.

■ Register Definitions

Addr	Register Name	D7	D6	D5	D4	D3	D2	D1	D0
00H	Control 1	0	CKS2	CKS1	CKS0	DIF2	DIF1	DIF0	RSTN
	default	0	0	0	0	0	0	0	1

RSTN: Internal timing reset

0: Reset. All registers are not initialized.

1: Normal Operation

When the states of CKS2-0 or DFS change, the AK4393 should be reset by PDN pin or RSTN bit.

DIF2-0: Audio data interface modes (see Table 5)

Initial: “000”, Mode 0

Register bits are ORed with DIF2-0 pins if P/S = “L”.

CKS2-0: Master Clock Frequency Select (see Table 2)

Initial: “000”, Mode 0

Register bits are ORed with CKS2-0 pins if P/S = “L”.

Addr	Register Name	D7	D6	D5	D4	D3	D2	D1	D0
01H	Control 2	0	0	0	0	DFS	DEM1	DEM0	SMUTE
	default	0	0	0	0	0	0	0	0

SMUTE: Soft Mute Enable

0: Normal operation

1: DAC outputs soft-muted

DEM1-0: De-emphasis response (see Table 6)

Initial: “00”, 44.1kHz

DFS: Sampling speed control (see Table 1)

0: Normal speed

1: Double speed

Register bit is ORed with DFS pin if P/S = “L”.

Addr	Register Name	D7	D6	D5	D4	D3	D2	D1	D0
02H	Test	TEST7	TEST6	TEST5	TEST4	TEST3	TEST2	TEST1	TEST0
	default	0	0	0	0	0	0	0	0

TEST7-0: Test mode. Do not write any data to 02H.

SYSTEM DESIGN

Figure 8 and 9 show the system connection diagram. An evaluation board (AKD4393) is available which demonstrates the optimum layout, power supply arrangements and measurement results.

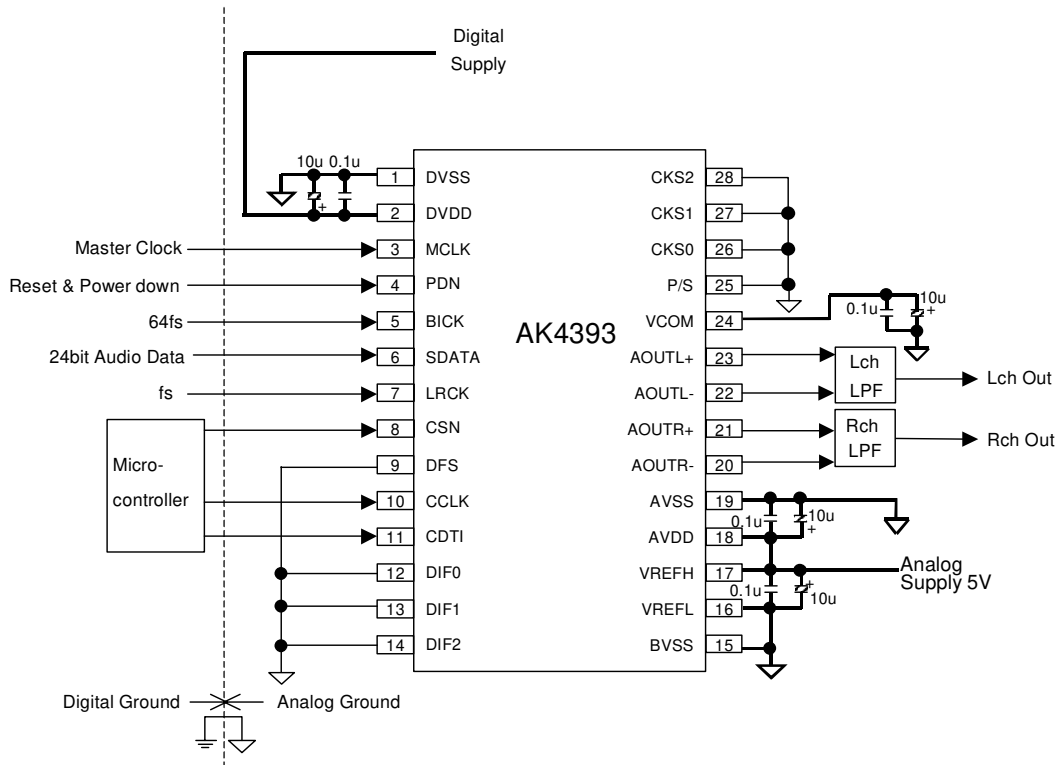

Figure 8. Typical Connection Diagram (Serial mode)

Notes:

- LRCK = fs, BICK = 64fs.
- Power lines of AVDD and DVDD should be distributed separately from the point with low impedance of regulator etc.
- AVSS, BVSS and DVSS must be connected to the same analog ground plane.
- When AOUT drives some capacitive load, some resistor should be added in series between AOUT and capacitive load.
- All input pins except pull-down/pull-up pins should not be left floating.

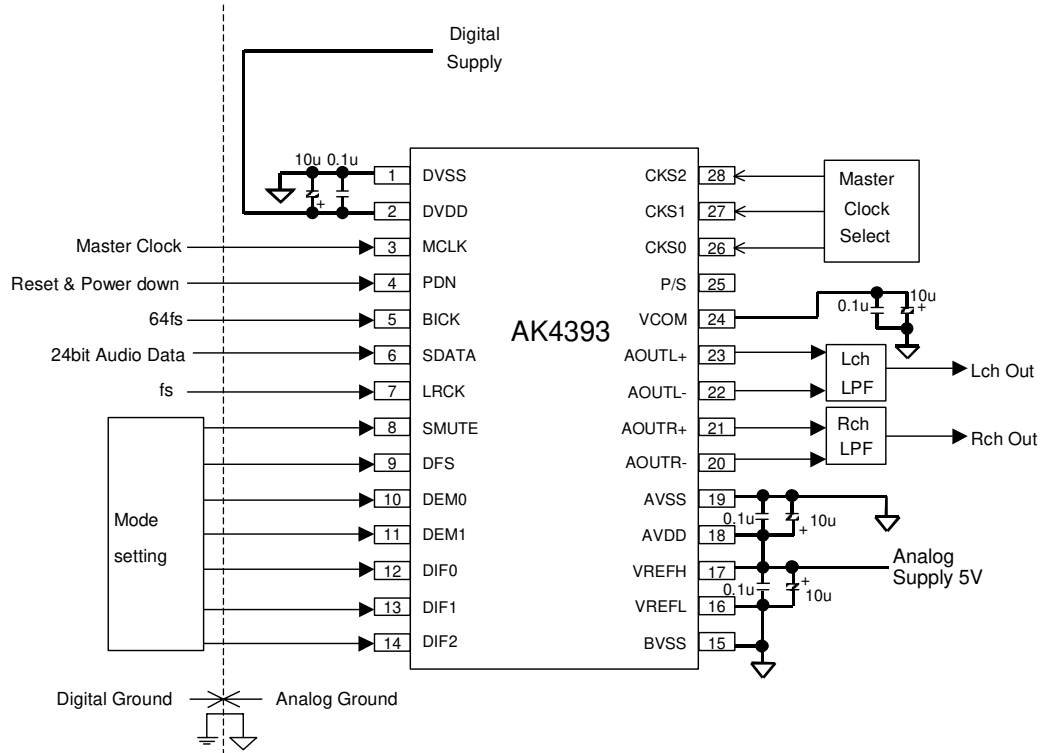

Figure 9. Typical Connection Diagram (Parallel mode)

Notes:

- LRCK = fs, BICK = 64fs.
- Power lines of AVDD and DVDD should be distributed separately from the point with low impedance of regulator etc.
- AVSS, BVSS and DVSS must be connected to the same analog ground plane.
- When AOUT drives some capacitive load, some resistor should be added in series between AOUT and capacitive load.
- All input pins except pull-down/pull-up pins should not be left floating.

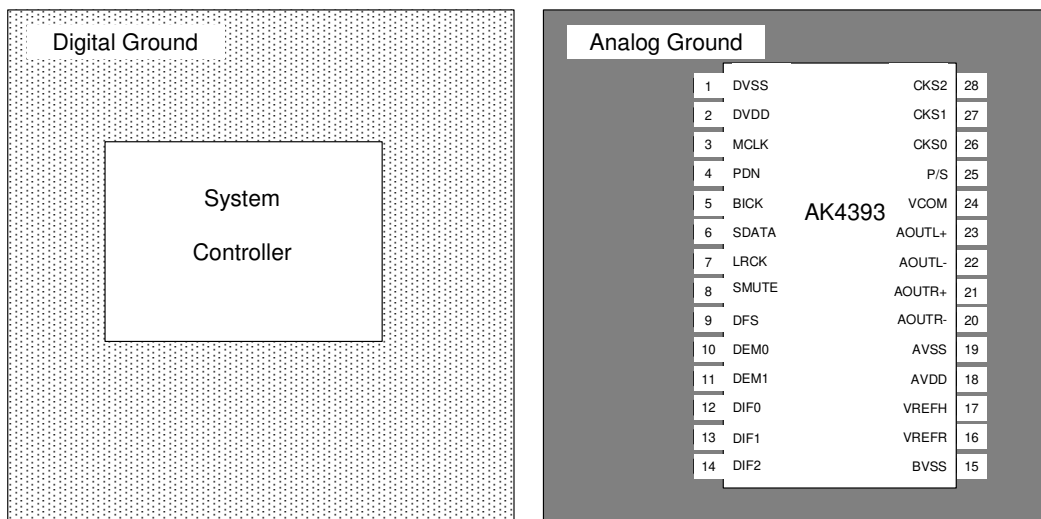

Figure 10. Ground Layout

1. Grounding and Power Supply Decoupling

To minimize coupling by digital noise, decoupling capacitors should be connected to AVDD and DVDD, respectively. AVDD is supplied from analog supply in system and DVDD is supplied from digital supply in system. If AVDD and DVDD are supplied separately, the power up sequence is not critical. **AVSS, BVSS and DVSS must be connected to analog ground plane.** System analog ground and digital ground should be connected together near to where the supplies are brought onto the printed circuit board. Decoupling capacitors for high frequency should be placed as near as possible.

2. Voltage Reference

The differential Voltage between VREFH and VREFL set the analog output range. VREFH pin is normally connected to AVDD and VREFL pin is normally connected to AVSS. VREFH and VREFL should be connected with a 0.1 μ F ceramic capacitor. VCOM is a signal ground of this chip. An electrolytic capacitor 10 μ F parallel with a 0.1 μ F ceramic capacitor attached to VCOM pin eliminates the effects of high frequency noise. No load current may be drawn from VCOM pin. All signals, especially clocks, should be kept away from the VREFH, VREFL and VCOM pins in order to avoid unwanted coupling into the AK4393.

3. Analog Outputs

The analog outputs are full differential outputs and 2.4Vpp (typ@VREF=5V) centered around VCOM. The differential outputs are summed externally, $V_{AOUT} = (AOUT+) - (AOUT-)$ between AOUT+ and AOUT-. If the summing gain is 1, the output range is 4.8Vpp (typ@VREF=5V). The bias voltage of the external summing circuit is supplied externally. The input data format is 2's complement. The output voltage (V_{AOUT}) is a positive full scale for 7FFFFFFH (@24bit) and a negative full scale for 800000H (@24bit). The ideal V_{AOUT} is 0V for 000000H (@24bit).

The internal switched-capacitor filters attenuate the noise generated by the delta-sigma modulator beyond the audio passband.

Figure 11 shows an example of external LPF circuit summing the differential outputs by an op-amp. Figure 12 shows an example of differential outputs and LPF circuit example by three op-amps.

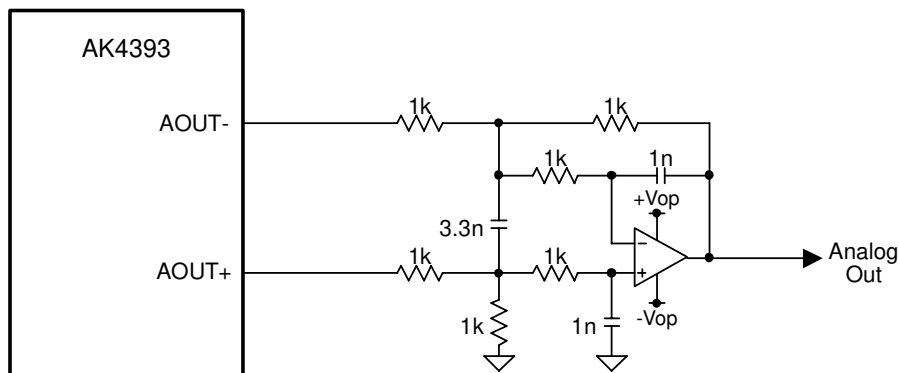

Figure 11. External LPF Circuit Example 1

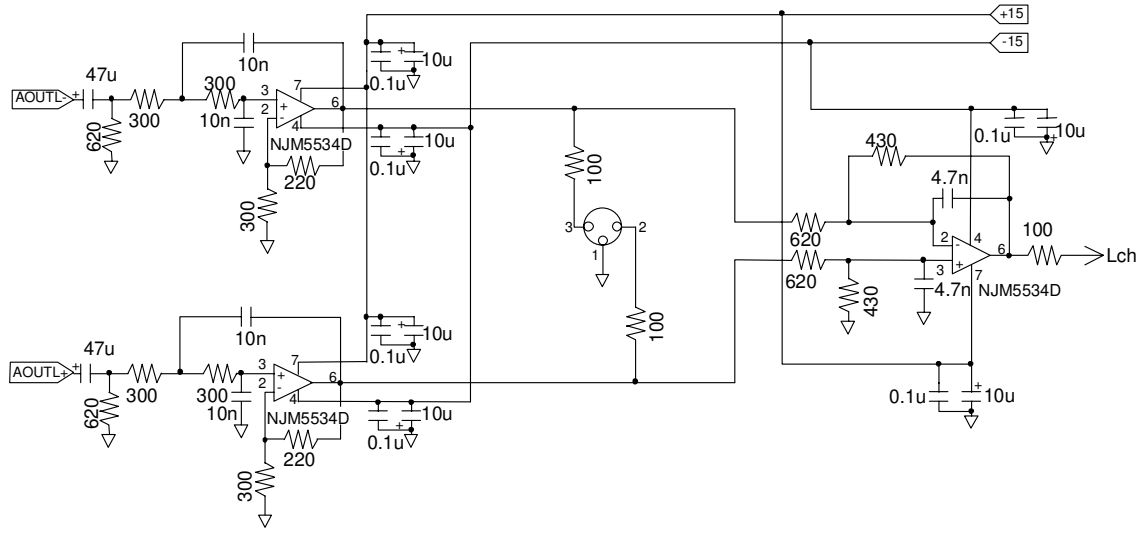
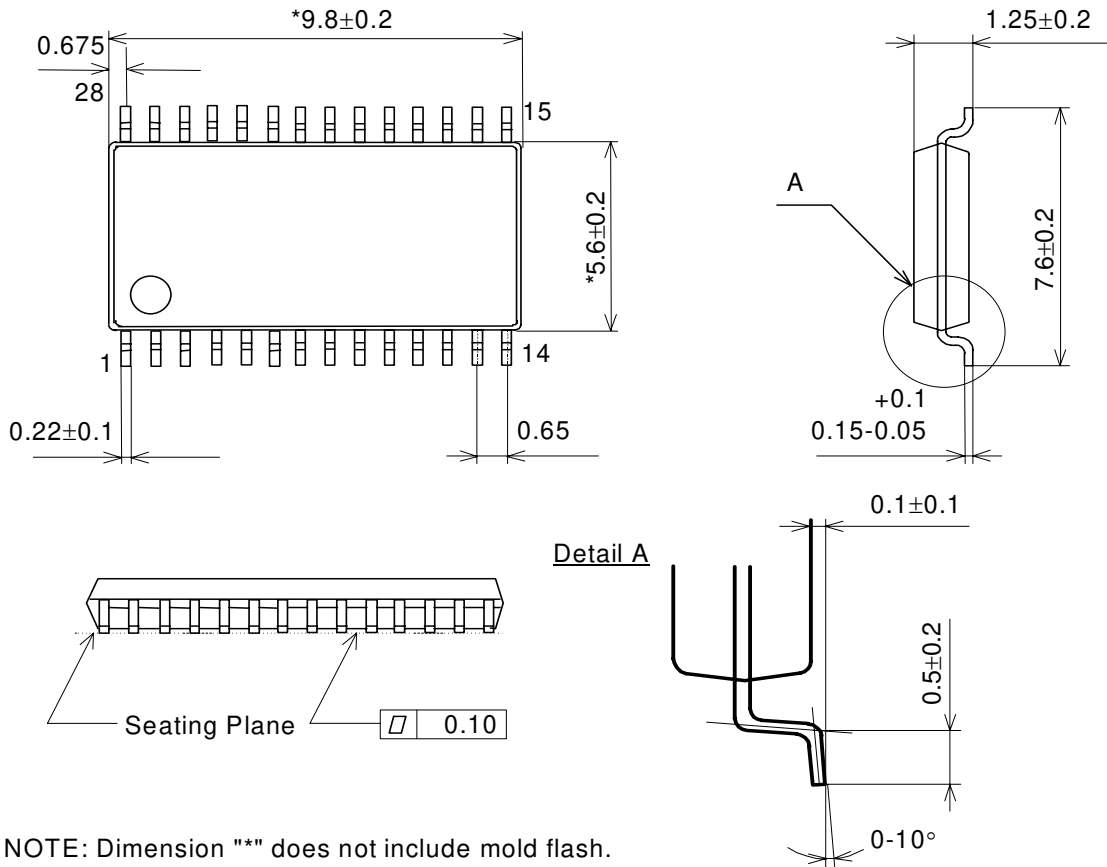

Figure 12. External LPF Circuit Example 2

PACKAGE

28pin VSOP (Unit: mm)



NOTE: Dimension "*" does not include mold flash.

Material & Lead finish

Package molding compound: Epoxy
 Lead frame material: Cu
 Lead frame surface treatment: Solder plate

MARKING

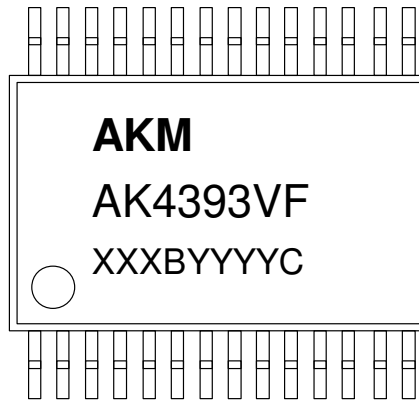

XXXXBYYYYC data code identifier

XXXB: Lot number (X : Digit number, B : Alpha character)
 YYYYYC: Assembly date (Y : Digit number C : Alpha character)

IMPORTANT NOTICE

- These products and their specifications are subject to change without notice. Before considering any use or application, consult the Asahi Kasei Microsystems Co., Ltd. (AKM) sales office or authorized distributor concerning their current status.
- AKM assumes no liability for infringement of any patent, intellectual property, or other right in the application or use of any information contained herein.
- Any export of these products, or devices or systems containing them, may require an export license or other official approval under the law and regulations of the country of export pertaining to customs and tariffs, currency exchange, or strategic materials.
- AKM products are neither intended nor authorized for use as critical components in any safety, life support, or other hazard related device or system, and AKM assumes no responsibility relating to any such use, except with the express written consent of the Representative Director of AKM. As used here:
 - (a) A hazard related device or system is one designed or intended for life support or maintenance of safety or for applications in medicine, aerospace, nuclear energy, or other fields, in which its failure to function or perform may reasonably be expected to result in loss of life or in significant injury or damage to person or property.
 - (b) A critical component is one whose failure to function or perform may reasonably be expected to result, whether directly or indirectly, in the loss of the safety or effectiveness of the device or system containing it, and which must therefore meet very high standards of performance and reliability.
- It is the responsibility of the buyer or distributor of an AKM product who distributes, disposes of, or otherwise places the product with a third party to notify that party in advance of the above content and conditions, and the buyer or distributor agrees to assume any and all responsibility and liability for and hold AKM harmless from any and all claims arising from the use of said product in the absence of such notification.

Appendix A

In Double Speed Mode, the phase relationship between MCLK and LRCK/BICK is limited (Table 7). If the phase relationship happens during this prohibited period, it is possible to occur the inverse of output channel. The phase relationship must be set to avoid the prohibited period when the AK4393 operates at Double Speed Mode. The prohibited period is specified by the combination of digital power supply voltage (DVDD), MCLK frequency and audio data format (Table 5). When the audio data formats are 16/20/24bit LSB Justified (Mode 0,1,4) and 24bit MSB Justified (Mode 2), the phase relationship (tLRM: Figure 11) between the rising edge of LRCK and the rising edge of MCLK has the prohibited period of min to max in Table 7. In case of I²S Compatible (Mode 3), the relationship between the falling edge of BICK and the rising edge of MCLK has the prohibited period (tBCM: Figure 12)

Sampling Mode	Digital Power Supply, DVDD	MCLK Frequency	Mode Setting				Prohibited Period		Units
			CKS2	CKS1	CKS0	DFS	min	max	
Double Speed	3.0 to 5.25V	128fs	0	0	0	1	0.4	1.7	ns
Double Speed	3.0 to 5.25V	192fs	0	1	0	1	-0.5	0.8	ns
Double Speed	3.0 to 5.25V	256fs	0	0	1	1	-0.7	0.7	ns
Double Speed	3.0 to 5.25V	256fs	1	0	0	1	-0.7	0.7	ns
Double Speed	3.0 to 5.25V	384fs	0	1	1	1	-1.7	-0.3	ns
Double Speed	3.0 to 5.25V	384fs	1	1	0	1	-1.7	-0.3	ns
Double Speed	4.75 to 5.25V	128fs	0	0	0	1	0.8	1.5	ns
Double Speed	4.75 to 5.25V	192fs	0	1	0	1	-0.2	0.5	ns
Double Speed	4.75 to 5.25V	256fs	0	0	1	1	-0.3	0.4	ns
Double Speed	4.75 to 5.25V	256fs	1	0	0	1	-0.3	0.4	ns
Double Speed	4.75 to 5.25V	384fs	0	1	1	1	-1.0	-0.3	ns
Double Speed	4.75 to 5.25V	384fs	1	1	0	1	-1.0	-0.3	ns

Table 7. Prohibited Period

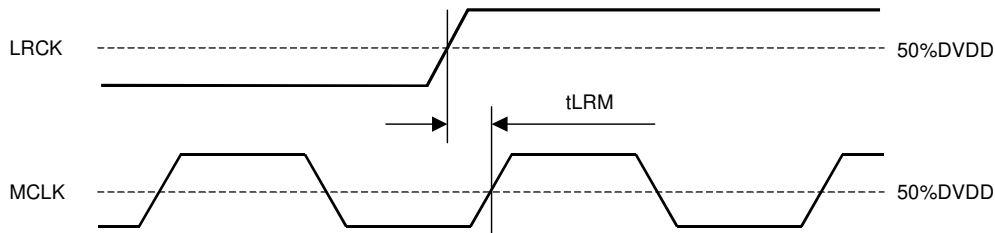

Figure 11. 16/20/24bit LSB Justified, 24bit MSB Justified

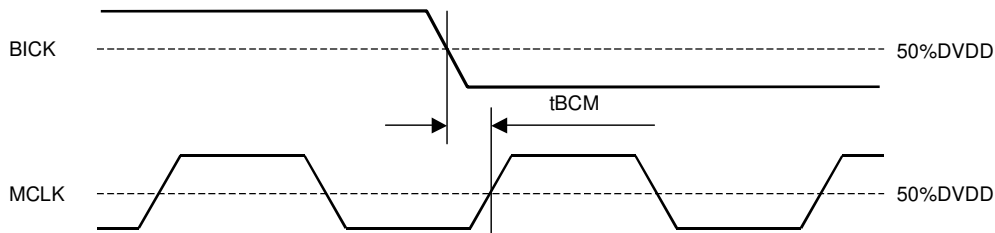

Figure 12. I²S Compatible