



Chipsmall Limited consists of a professional team with an average of over 10 year of expertise in the distribution of electronic components. Based in Hongkong, we have already established firm and mutual-benefit business relationships with customers from,Europe,America and south Asia,supplying obsolete and hard-to-find components to meet their specific needs.

With the principle of "Quality Parts,Customers Priority,Honest Operation,and Considerate Service",our business mainly focus on the distribution of electronic components. Line cards we deal with include Microchip,ALPS,ROHM,Xilinx,Pulse,ON,Everlight and Freescale. Main products comprise IC,Modules,Potentiometer,IC Socket,Relay,Connector.Our parts cover such applications as commercial,industrial, and automotives areas.

We are looking forward to setting up business relationship with you and hope to provide you with the best service and solution. Let us make a better world for our industry!



Contact us

Tel: +86-755-8981 8866 Fax: +86-755-8427 6832

Email & Skype: info@chipsmall.com Web: www.chipsmall.com

Address: A1208, Overseas Decoration Building, #122 Zhenhua RD., Futian, Shenzhen, China





AK7451

Zero Latency Angle Sensor IC

1. General Description

The AK7451 is a magnetic rotational angle sensor IC of Si monolithic with a built-in Hall element, and easily achieve a non-contact rotation angle sensor in combination with diametrically magnetized two pole magnet.

By detecting the magnetic field parallel vector to the IC package surface, the AK7451 outputs the absolute angular position of the magnet, and the relative angular position.

By transverse magnetic field detection method using a magnetic flux concentrator, the AK7451 has excellent axial misalignment immunity.

AK7451 is the Zero Latency rotation angle sensor to follow up to 20,000rpm with the architecture of the tracking servo system, it is suitable to various motor drive applications and an encoder applications.

2. Features

- Monolithic integrated 360 degrees angle sensor IC containing Hall element.
- Easy to make a contactless rotation sensor with diametrically magnetized two pole magnet.
- Interfaces : SPI(absolute angle), ABZ phase output (incremental Interface), UVW phase output
- 12bit angle resolution
- Less than ± 0.6 deg. angle accuracy at 25 °C
- Maximum tracking speed : 333 rps (20,000 rpm)
- Angle output delay time: 1.8 μ s
- Operating ambient temperature: -40 to 125°C
- Various abnormal detection; abnormal magnetic flux density range etc.
- Various setting functions; angle zero point, rotation direction, ABZ resolution/hysteresis etc.

3. Table of Contents

1. General Description	1
2. Features	1
3. Table of Contents	2
4. Block Diagram and Functions	3
5. Pin Configurations and Functions	5
6. Absolute Maximum Ratings	6
7. Recommended Operating Conditions	6
8. EEPROM Characteristics	6
9. Electrical and Magnetic Characteristics	7
10. Serial Interface Characteristics	8
11. Digital Output Characteristics	10
12. Instructions	11
13. Mode Transition Diagram and Conditions	12
14. Serial Interface	13
15. Register / EEPROM Address Map / Configuration	15
16. ABZ Output Figure	26
17. UVW Output Figure	27
18. Abnormal Detection Functions	28
19. Angle Zero Position at Shipment, and Relation between Magnet Angle Position and Output	29
20. Package Information	30
20.1. Outline Dimensions	30
20.2. Marking	31
Important Notice	32

4. Block Diagram and Functions

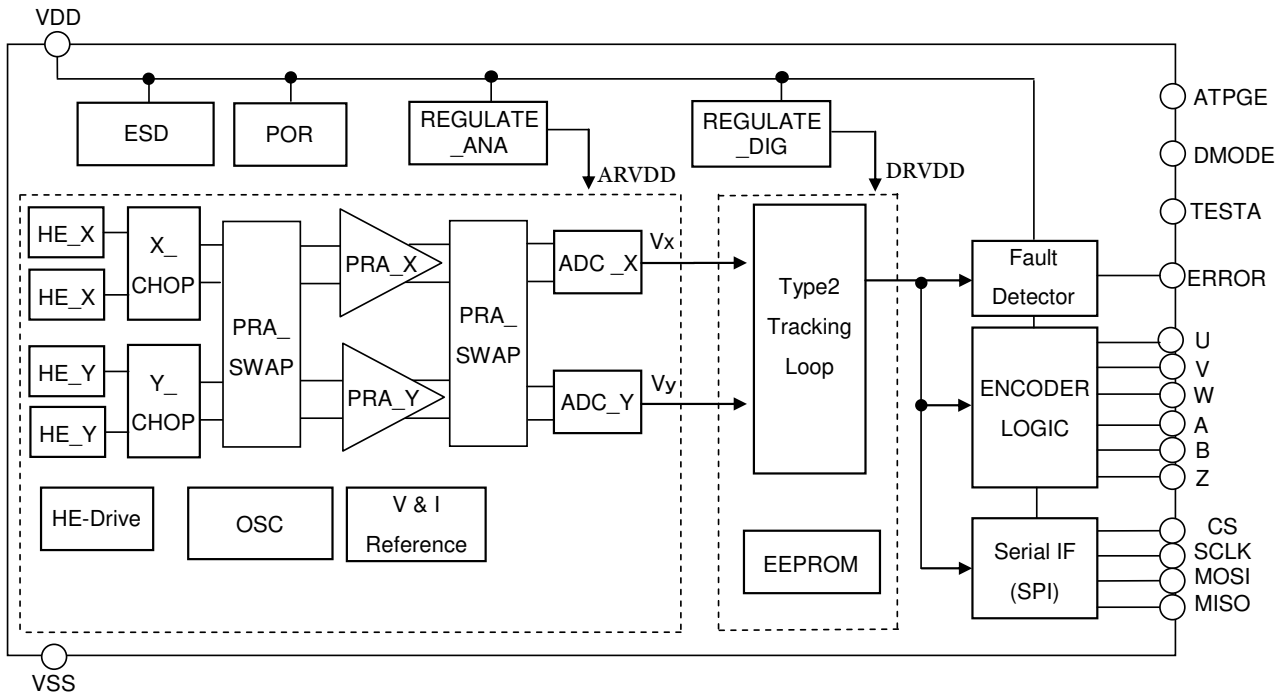

Figure 1. Functional block diagram of AK7451

Table 1. Description of circuit block

Circuit Block	Function
HE-X/Y	Si monolithic Hall elements. These detect X/Y-compositions of flux which are parallel to the IC package surface by using the magnetic concentrator and converts to an electrical signal.
X_CHOP, Y_CHOP	Switch its direction of drive current in order to lower offset and noise for the Hall elements.
HE Drive	Drive Hall elements by constant current.
PRA_X,PRA_Y	Amplify signals from Hall elements.
PRA_SWAP	Reduce mismatch of each amplifier gain and Hall element current.
ADC_X, ADC_Y	AD converter for converting the Hall electromotive force signal amplified in the preamplifier into a digital signal.
OSC_8MEG	Generate a master clock (8 MHz).
V & I Reference	Generate reference voltage / current.
Type2 Tracking Loop	Closed loop circuit to calculate an angle from the digitalized Hall signal.
POR	Power-On-Reset circuit.
REGULATE_ANA	Regulate the power supply voltage and generate the internal ARVDD which is for analog circuit.
REGULATE_DIG	Regulate the power supply voltage and generate the internal DRVDD which is for digital circuit.
EEPROM	Non-volatile memory.
Fault Detector	Detect abnormal status such as magnetic flux density range and losing tracking state.
Encoder Logic	Generate ABZ and UVW phase signal based on absolute angle data.
Serial IF	4-wire SPI interface circuit.
ESD	Protection circuit for ESD

5. Pin Configurations and Functions

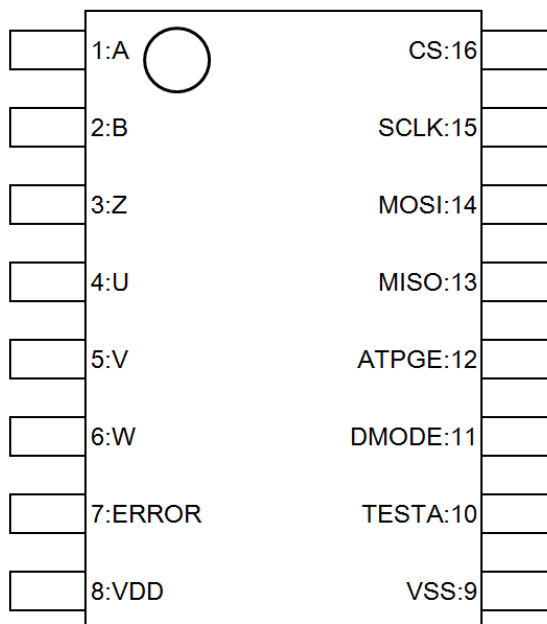

Figure 2. Pin assignment of AK7451

Table 2. Pin configuration and functions of AK7451

No.	Pin Name	I/O	Type	Description
1	A	O	Digital	A-phase Pulse Signal
2	B	O	Digital	B-phase Pulse Signal
3	Z	O	Digital	Z-phase Pulse Signal
4	U	O	Digital	U-phase Pulse Signal
5	V	O	Digital	V-phase Pulse Signal
6	W	O	Digital	W-phase Pulse Signal
7	ERROR	O	Digital	ERROR output PIN
8	VDD	-	Power	Power Supply PIN
9	VSS	-	GND	Ground PIN
10	TESTA	I/O	Analog	TEST dedicated PIN. This pin should be non-connection.
11	DMODE	I	Digital	TEST dedicated PIN. This pin should be non-connection.
12	ATPGE	I	Digital	TEST dedicated PIN. This pin should be non-connection.
13	MISO	O	Digital	SPI output data signal
14	MOSI	I	Digital	SPI Input Data Signal
15	SCLK	I	Digital	SPI Clock Signal
16	CS	I	Digital	SPI Chip Select Signal

6. Absolute Maximum Ratings

Table 3. Absolute Maximum Ratings

Parameter	Symbol	Min.	Max.	Units	Notes
Power Supply Voltage	V_{DDA}	-0.3	6.5	V	VDD pin
Voltage on Output pin	V_{OUT}	-0.3	V_{DDA}	V	MISO,ERROR,A,B,Z, U,V,W pin
Output Current on Output pin 1	I_{OUT1}	-1.25	1.25	mA	MISO pin
Output Current on Output pin 2	I_{OUT2}	-10	10	mA	ERROR,A,B,Z,U,V,W pin
Input pin Voltage	V_{IN}	-0.3	$V_{DDA} + 0.3$ ($\leq 6.5V$)	V	MOSI,CS,SCLK, DMODE,ATPGE, TESTA pin
Storage temperature	T_{STG}	-50	+150	°C	

WARNING: Stress beyond these listed values may cause permanent damage to the device. Even it may not cause damage on the device; it may affect its reliability and longevity.
Normal operation is not guaranteed. Each voltage is with respect to VSS pin.

7. Recommended Operating Conditions

Table 4. Operating conditions

Parameter	Symbol	Min.	Typ.	Max.	Units	Notes
Power Supply Voltage under Operating Conditions	V_{DD}	4.5	5	5.5	V	VDD pin
Operating Ambient Temperature	T_a	-40	-	+125	°C	

WARNING: Exceeding the operation conditions, the electric and magnetic characteristics are not guaranteed. Voltage is with respect to VSS pin.

8. EEPROM Characteristics

Table 5. EEPROM Characteristics
Conditions : $V_{DD} = 4.5$ to $5.5V$

Parameter	Symbol	Min.	Typ.	Max.	Units	Notes
Endurance to rewriting	W_f			1000	cycle	
Ambient Temperature in writing	T_{MEM}	0		85	°C	
Writing time	W_t			5	ms	

9. Electrical and Magnetic Characteristics

Table 6 . Electrical and Magnetic Characteristics

Conditions (unless otherwise specified) : $T_a = -40$ to 125°C , $V_{DD} = 4.5$ to 5.5V

Parameter	Symbol	Conditions	Min.	Typ.	Max.	Unit
Magnetic Flux Density Range	B_{RANGE}		30	50	70	mT
Angle Detection Range	A_{RANGE}		0			deg.
Angle Resolution	A_{RES}	12bit		0.088		deg.
Angle Linearity Error (Note 1)	A_{INL}	at 25°C	-0.6		+0.6	deg.
Thermal Angle Drift	A_{DRIFT}	Operating temperature range (with reference to 25°C)	-0.9		+0.9	deg.
Angle hysteresis Width	A_{HYS}	at 25°C			0.3	deg.
Output noise	H_{NOISE}	at 50mT	-2		2	LSB
Angle Tracking Ability	F_{SAMP}				20000	rpm
Angle Output Delay Time (Note 2)	T_{D}	at ABZ hysteresis configuration = "Invalid"			1.8	μs
Power On Time (Note 3)	T_{STO}			25	30	ms
Supply current	I_{SUP}	No Output Load		12.7	15.7	mA

Note 1. If ABZ resolution configuration is set to other than exponentiation of 2, the angle linearity error is added to the specified value in 0 to 1LSB (0 to 0.088degree).

Note 2. This value is in case that ABZ hysteresis configuration is set to "Invalid". This value is dependent on ABZ hysteresis configuration. Whenever the setting value is increased, the angle output delay time value increases by $0.5\mu\text{s}$ at a time.

Note 3. It is the time from Power-On to becoming high on ERROR pin through judging magnetic flux range error and tracking error. This time is including the circuit setup time, the tracking angle time, the self-diagnosis of error time. This parameter is not tested at mass production.

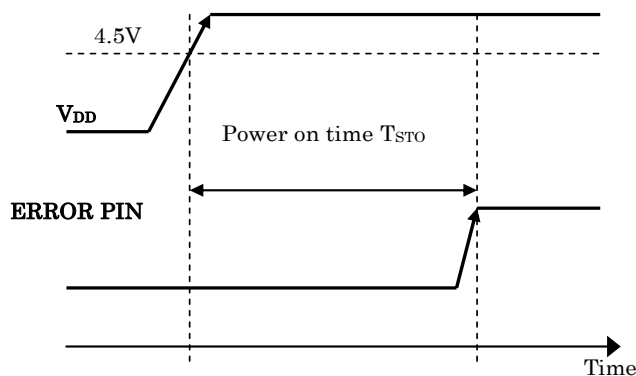

Figure 3. Waveform of VDD and ERROR pin at start-up

10. Serial Interface Characteristics

Table 7. Serial I/F DC Characteristics

Conditions : Ta=-40 to 125°C, V_{DD}=4.5 to 5.5V

Parameter	Symbol	PIN	Conditions	Min.	Typ.	Max.	Unit
Input High Level	V _{HSI}	CS,SCLK, MOSI		0.7V _{DD}			V
Input Low Level	V _{LSI}	CS,SCLK, MOSI				0.3V _{DD}	V
Input Current	I _{SI}	CS,SCLK, MOSI		-10		+10	μA
Output Current	I _{SO}	MISO		-1		1	mA
Output High Level	V _{HSO}	MISO	I _{SO} =1mA (source)	0.8V _{DD}			V
Output Low Level	V _{LSO}	MISO	I _{SO} =1mA (sink)	-0.3		0.2V _{DD}	V
Output Load Capacity	C _{SO}	MISO				100	pF

Table 8. Serial I/F AC Characteristics

Conditions : Ta=-40 to 125°C, V_{DD}=4.5 to 5.5V

Parameter	Symbol	Min	Typ.	Max	Unit	Notes
Time from fall of CS to start of CLK	t1	100			ns	
Necessary Time from end of SCLK to rise of CS	t2	100			ns	
Set-up time of input data	t3	70			ns	
Hold time of input data	t4	70			ns	
Time to fix output data	t5			150	ns	
Time from rise of CS to Hi-Z of MISO	t6	0		500	ns	
Transition time from 0.2V _{DD} to 0.8V _{DD} of output data	t7			100	ns	
Transition time from 0.8V _{DD} to 0.2V _{DD} of output data	t8			100	ns	
SCLK High time	t9	200			ns	
SCLK Low time	t10	200			ns	
SCLK Rise time (Note 4)	t11			30	ns	
SCLK Fall time (Note 4)	t12			30	ns	
Idle time in writing register	t13	2.5			μs	
Idle time in writing EEPROM	t13	5			ms	
SCLK Frequency	-	0.001		2000	kHz	

Note 4. These parameters are not tested at mass production.

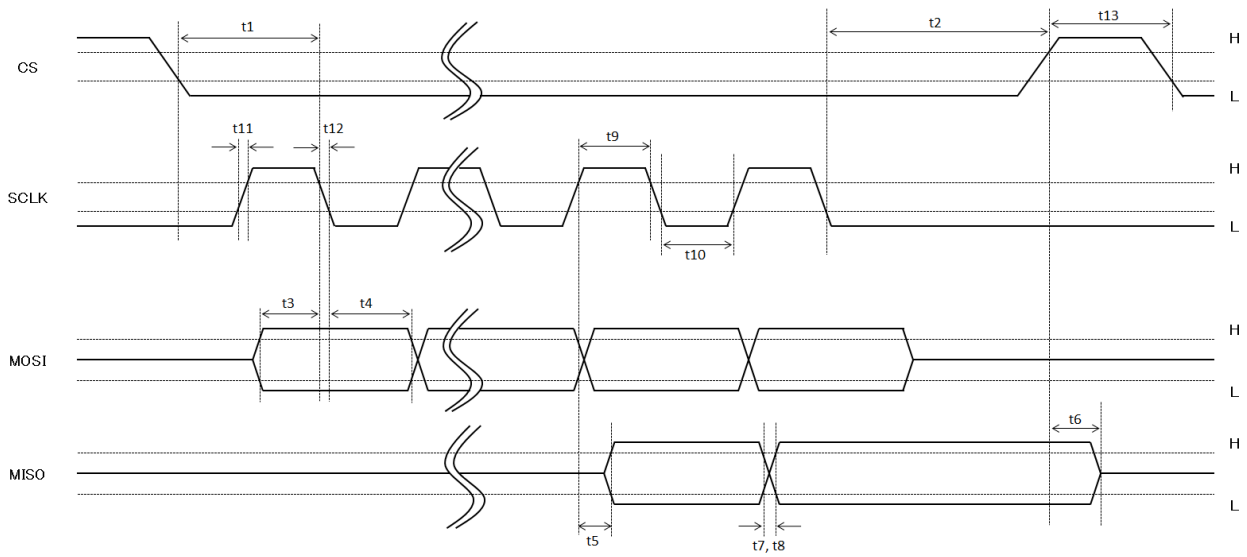

Figure 4. AC Timing of Serial I/F

11. Digital Output Characteristics

Table 9. Digital Output DC Characteristics
 Conditions :Ta=-40 to 125°C, V_{DD}=4.5 to 5.5V

Parameter	Symbol	Pin	Notes	Min	Typ.	Max	Unit
Output Current	I _{DO}	A,B,Z, U,V,W, ERROR		-2		2	mA
Output Low Level	V _{LDO}	A,B,Z, U,V,W, ERROR	I _{DO} =2mA(sink)	-0.3		0.2V _{DD}	V
Output High Level	V _{HDO}	A,B,Z, U,V,W, ERROR	I _{DO} =2mA(source)	0.8V _{DD}			V
Output Load Capacity	C _{DO}	A,B,Z, U,V,W, ERROR				100	pF

Table 10. Digital Output AC Characteristics
 Conditions :Ta=-40 to 125°C, V_{DD}=4.5 to 5.5V

Parameter	Symbol	Pin	Notes	Min	Typ.	Max	Unit
Rise time	T _{RDO}	A,B,Z, U,V,W, ERROR	C _{DO} =100pF, I _{DO} =2mA(source) Time from 0.2V _{DD} to 0.8V _{DD}			150	ns
Fall time	T _{FDO}	A,B,Z, U,V,W, ERROR	C _{DO} =100pF, I _{DO} =2mA(sink) Time from 0.8V _{DD} to 0.2V _{DD}			150	ns

12. Instructions

The AK7451's function is described in this section. The function is roughly divided into programming procedure (for various setup) and an angle measurement procedure. The operation procedure is as follows.

<Programming Procedure>

1. The AK7451 will start as "Normal Mode" after power on automatically.
2. Transfer to "User Mode" and write configuration parameters in EEPROM and then verify the data.
3. Transfer to "Normal Mode" and then The AK7451 will output the angle data based on programmed parameter.

<Normal Operation (Angle measurement)>

1. Transfer to "Normal Mode".
2. Input the "read angle command" as OPCODE"1001" via SPI, when the absolute angle data is needed. If relative angle data is needed, count the ABZ output pulses. The ABZ pulses and UVW pulses are outputted right after startup along with magnet rotating.

13. Mode Transition Diagram and Conditions

This IC has the following two modes and starts with “Normal Mode” at start up.

In the “Normal Mode”, this sensor will be operated as angle output mode. User can read the angle data via SPI pin and ABZ pin and also can transfer to “User Mode” by using specific OPCODE. And also in this mode, UVW output is available to detect the magnet rotor position in BCDL motor driving.

In the “User Mode”, the user can set the various operation conditions via SPI communication. The settable item will be described later in this section.

Mode name	Note
Normal Mode	In this mode, The absolute angle data including error bit, parity bit and mode information will be outputted via SPI communication by inputting specific OPCODE. And the ABZ and UVW pulses are outputted automatically along with magnet rotating.
User Mode	Do not use the angle data (ABZ and UVW pulses) in this mode. The following functions are available in this mode. a. Magnetic flux density measurement b. Abnormal state checking c. Memory lock d. Angle zero position setting e. ABZ output enable/disable and resolution, hysteresis setting f. Abnormal detection enable/disable setting g. Rotation direction setting h. UVW output enable/disable and the number of output pulses, hysteresis setting

Note 5. In user mode, output on ERROR PIN is low state (abnormal status). And the accuracy of magnetic flux density measurement is not guaranteed.

Each mode can be changed by writing specific OPCODE and specific data on specific address as the diagram below.

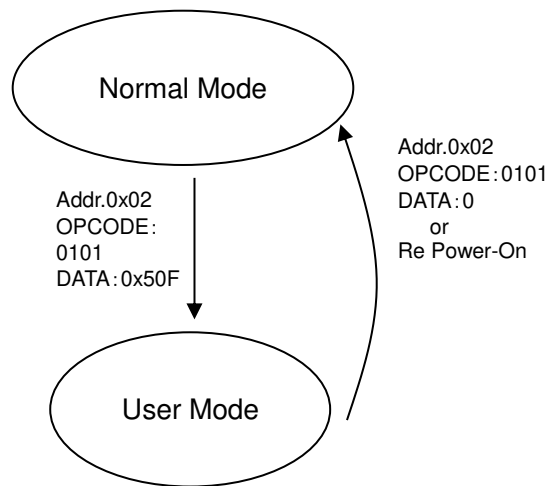

Figure 5. Mode transition diagram

14. Serial Interface

When register/memory setting or absolute angle measurement is needed, use SPI communication. The serial communication protocol and each register/memory description are described in this section.

● Data format

1) Write memory/register in User Mode

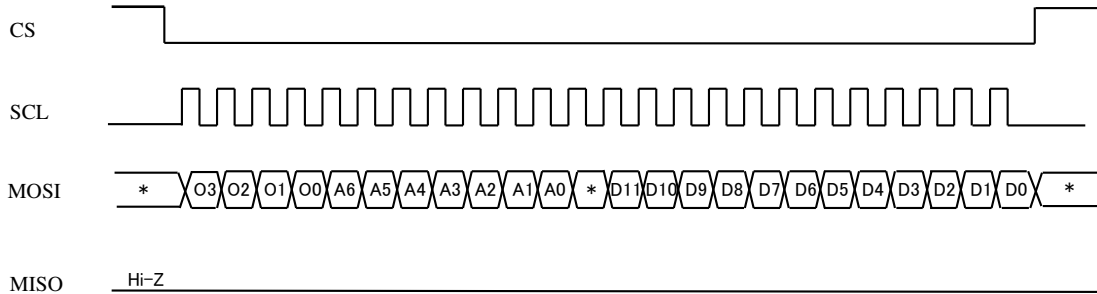

2) Read memory register in User Mode

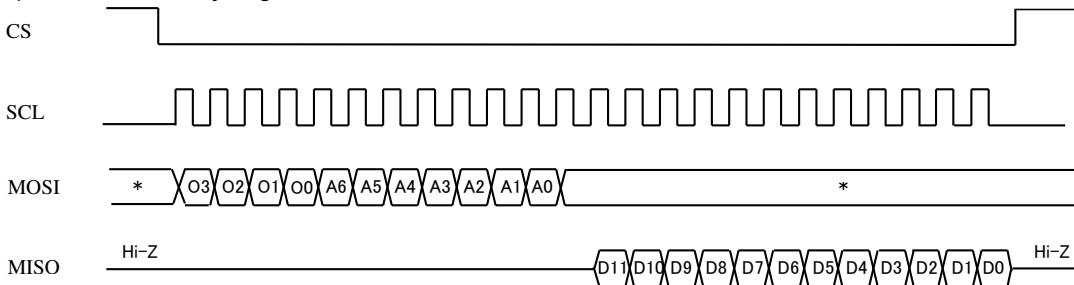

3) Read angle data in Normal Mode

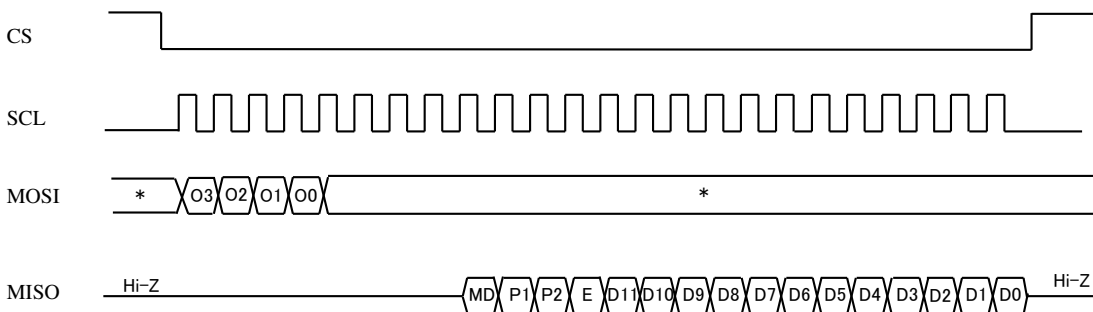

Figure 6. Timing Chart of Serial I/F

Note 6. Figure symbols are as following;

- 'Ox': Operation Code
- 'Ax': Memory/Register Address
- 'MD': Mode Information (MD is "0" in Normal Mode, And "1" in User Mode)
- 'Dx': Data
- 'P1': Parity Bit for Angle Data[11:6]
- 'P2': Parity Bit for Angle Data[5:0]
- 'E': Error Bit (Normal=1, Abnormal=0)
- '*': Don't Care.

Note 7. Parity bit is odd parity in normal and even parity in abnormal. And the ABZ hysteresis configuration which is described later in this section is reflected in read angle data.

Note 8. Send data and receive data are from MSB to LSB in sequence.

Table 11. OPCODE Specification

OPCODE[3:0]	OPCODE name	Note
0000	N.A.	
0001	Write EEPROM	Able to write a data on EEPROM.
0010	Read EEPROM	Able to read an EEPROM.
0011	Write Register	Able to write a data on register.
0100	Read Register	Able to read a register.
0101	Change MODE	Able to change between normal mode and user mode. Transition conditions are described in '14.1. Mode Transition Diagram and Conditions '.
0110	N.A.	
0111	N.A.	
1000	Angle Data Renew	Update the ANG, MAG, ERRMON, ERR bit data.
1001	Read Angle	Read the angle data.
1010	N.A.	
1011	N.A.	
1100	N.A.	
1101	N.A.	
1110	N.A.	
1111	N.A.	

15. Register / EEPROM Address Map / Configuration

● **Register Address Map**

Table 12. Register Address Map

Addr. [HEX]	Register symbol	R/W Permission		Note
		Normal Mode	User Mode	
0x00	R_ANG	R	R	12bit angle data
0x01	R_MAG	N.A.	R	Magnetic flux density strength (roughly 1LSB/mT)
0x02	R_CHMD	W	R/W	For mode state
0x03	R_ERRMON	N.A.	R	Error monitor (This register will show what kind of error is.)
0x04	-	N.A.	N.A.	
0x05	-	N.A.	N.A.	
0x06	R_ZP	N.A.	R/W	For set up angle zero point
0x07	R_RDABZ	N.A.	R/W	For set up "Rotation direction", "Z phase output form", "ABZ output enable/disable", "ABZ Hysteresis" and "ABZ resolution".
0x08	R_MLK	N.A.	R	For memory lock
0x09	R_EBDIS	N.A.	R/W	For set up abnormal detection disable
0x0A	R_UVW	N.A.	R/W	For set up "UVW output enable/disable", "UVW Hysteresis" and "UVW resolution".

Note 9. N.A. = Not Available, R = Read Only, R/W = Read and Write

Note 10. Address 0x02 is only able to be changed by writing OPCODE"0101"

● **Each Register Configurations**

- R_ANG Register (Register Address:0x00)

R_ANG	D11	D10	D9	D8	D7	D6	D5	D4	D3	D2	D1	D0
Content	R_ANG[11:0]											

Register Function: This register contains an output angle data. The angle data consists with the following angle position. And the ABZ hysteresis configuration which is described later in this section is reflected in this register's value.

Angle Position [°]	R_ANG[11:0]
0	0x000
(360÷4096) ×1	0x001
(360÷4096) ×2	0x002
(360÷4096) ×3	0x003
⋮	⋮
(360÷4096) ×4095	0xFFF

- R_MAG Register (Register Address:0x01)

R_MAG	D11	D10	D9	D8	D7	D6	D5	D4	D3	D2	D1	D0
Content							R_MAG[6:0]					

Register Function: This register contains a magnetic flux density strength data. The magnetic flux density strength data consists with the following magnetic flux density strength.

Magnetic Flux Density Strength [mT]	R_MAG[6:0]
0	0x00
1	0x01
2	0x02
3	0x03
⋮	
127	0x7F

Note 11. This magnetic flux density measurement data's accuracy which is stored in this register is not guaranteed, It is recommended to use for only reference.

- R_CHMD Register (Register Address : 0x02)

R_CHMD	D11	D10	D9	D8	D7	D6	D5	D4	D3	D2	D1	D0
Content	R_CHMD[11:0]											

Register Function: This register is to configure the mode (Normal Mode/User Mode). This register can be written by using OPCODE [0101]. Each mode configuration is the following.

Mode	R_CHMD[11:0]	Default
Normal Mode	0x000	•
User Mode	0x50F	

- R_ERRMON Register (Register Address : 0x03)

R_ERRMON	D11	D10	D9	D8	D7	D6	D5	D4	D3	D2	D1	D0
Content											R_ERRMON [1:0]	

Register Function : This register shows the error state. Corresponding bit data is 0 in the abnormal state. Relation between the abnormal state and bit data is the following.

Abnormal State	Bit data	Value in Abnormal State	Value in Normal State
Magnetic Flux Density Strength Abnormity	R_ERRMON[1]	0	1
Tracking Lost	R_ERRMON[0]	0	1

- R_ZP Register (Register Address : 0x06)

R_ZP	D11	D10	D9	D8	D7	D6	D5	D4	D3	D2	D1	D0
Content	R_ZP[11:0]											

Register Function: This register is available for setting arbitrarily angle position as zero position. Relation between the angle position and the ZP data is the following. The register value is duplicated from corresponding memory after power on or, when the mode transferred to "Normal Mode" from "User Mode".

Zero Point Angle Position [°]	R_ZP[11:0]	Default
0	0x000	●
(360÷4096) ×1	0x001	
(360÷4096) ×2	0x002	
(360÷4096) ×3	0x003	
⋮	⋮	
(360÷4096) ×4095	0xFFFF	

Note 12. A setup of this register is reflected in ABZ and UVW output.

- R_RDABZ Register (Register Address : 0x07)

R_RDABZ	D11	D10	D9	D8	D7	D6	D5	D4	D3	D2	D1	D0
Content			R_RD	R_Z_MODE	R_ABZ_E	R_ABZ_HYS[2:0]			R_ABZ_RES[3:0]			

Register Function: This register is used for configuring "Rotation direction", "Z phase output form", "ABZ output enabling / disabling", "ABZ phase hysteresis" and "ABZ resolution". The register value is duplicated from corresponding memory after power on or, when the mode transferred to "Normal Mode" from "User Mode".

- a) **Rotation direction configuration:** The output direction can be set in if the angle data increases clockwise or clockwise (Refer to section 16). Relation between the rotation direction and RD is as following.

Rotation Direction	R_RD	Default
CCW (+)	0x0	●
CW (-)	0x1	

- b) **Z phase output form configuration:** The Z phase can be set as either among two modes. One is a normal z phase output which carries out toggle at 0 degree position. The other is a switch output which keeps low state in more than 180 degree and high state in less than 180 degree. (Refer to section 14.3 ABZ output figure)

Z phase output form	R_Z_MODE	Default
Normal output	0x0	●
Switch output	0x1	

- c) **ABZ output enable configuration:** It is possible to disable the ABZ output as necessary. When the ABZ output is set to "inability (0x0)", the output becomes Hi-Z.

ABZ Output State	R_ABZ_E	Default
ABZ Output Inability (Hi-Z output)	0x0	
ABZ Output	0x1	●

d) **ABZ hysteresis configuration:** This configuration can be used to prevent unexpected ABZ pulses under noise influence. Relation between ABZ hysteresis and ABZ_HYS set value is as following.

ABZ Hysteresis	R_ABZ_HYS[2:0]	Default
Invalid	0x0	
0LSB	0x1	
1LSB	0x2, 0x5, 0x6, 0x7	●
2LSB	0x3	
3LSB	0x4	

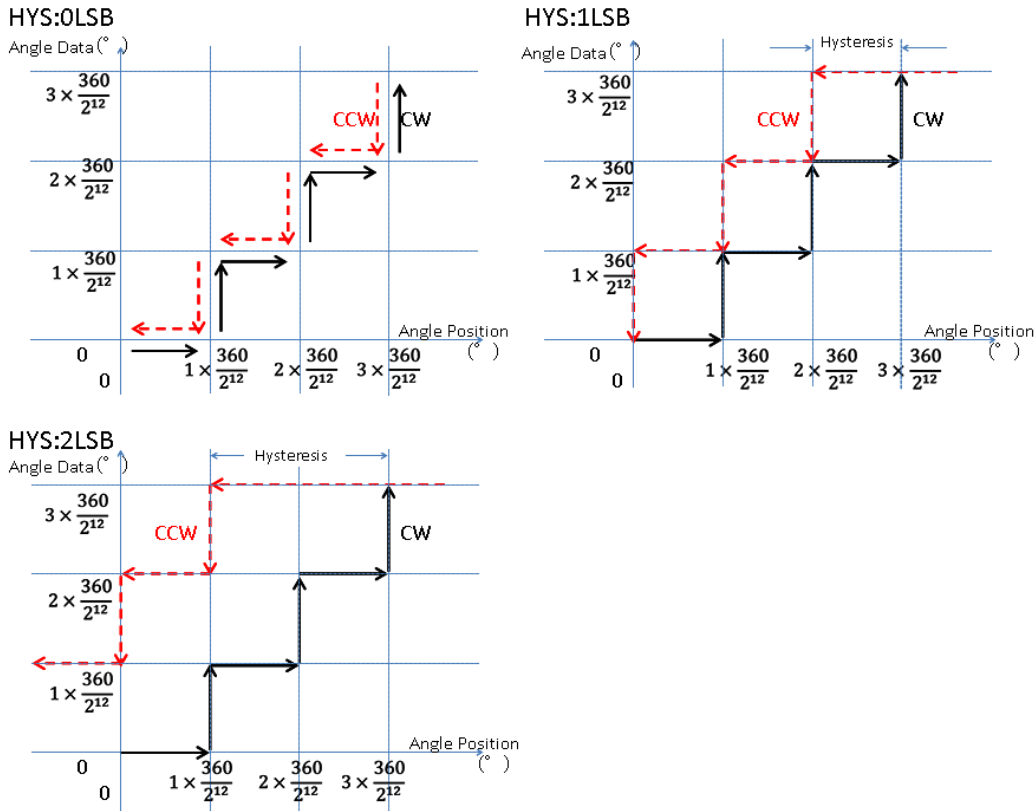

Figure 7. Operational Overview of Hysteresis Configuration

Note 13. As to the difference of ABZ hysteresis between “0LSB” and “Invalid”; Internal angle data always alternates between two adjacent angle data because of the tracking loop characteristics even if the environment is a static condition. In “Invalid” configuration, ABZ output is reflected by internal angle data directly. But in “0LSB” configuration, ABZ output is reflected by internal angle data when internal angle data change over two consecutive LSB in same rotation direction. Thus in this case, LSB bit alternation caused by noise is masked from ABZ output.

- e) **ABZ output resolution configuration:** Able to configure the ABZ resolution. Relation between ABZ resolution and set value is as following.

ABZ phase resolution	R_ABZ_RES[D3:0]	Default
1024ppr	0x0	•
512ppr	0x1	
256ppr	0x2	
128ppr	0x3	
100ppr	0x4	
900ppr	0x5	
800ppr	0x6	
700ppr	0x7	
600ppr	0x8	
500ppr	0x9	
400ppr	0xA	
360ppr	0xB	
300ppr	0xC	
200ppr	0xD	
100ppr	0xE	
50ppr	0xF	

- R_MLK Register (Register Address : 0x08)

R_MLK	D11	D10	D9	D8	D7	D6	D5	D4	D3	D2	D1	D0
Content												R_MLK[1:0]

Register Function: This register is to be duplicated from data at the memory lock configuration address on EEPROM. This address is read-only for confirming the memory lock state. Relation between the memory lock state and MLK register value is as following.

Memory Lock State	R_MLK[1:0]	Default
Unlocked	0x3	•
Locked	0x0, 0x1, 0x2	

- R_EBDIS Register (Register Address : 0x09)

R_EBDIS	D11	D10	D9	D8	D7	D6	D5	D4	D3	D2	D1	D0
Content												R_EBDIS[1:0]

Register Function: This register is used for disabling / enabling each abnormal diagnosis function as necessary. Relation between the diagnosis function and EBDIS is as following. Each bit have its function, and "1" means DISABLE. The register value is duplicated from corresponding memory after power on or, when the mode transferred to "Normal Mode" from "User Mode".

Abnormal Diagnosis Parameter	Bit data	Default
Magnetic Flux Density	R_EBDIS[1]	0
Tracking Lost	R_EBDIS[0]	0

- R_UVW Register (Register Address : 0x0A)

R_UVW	D11	D10	D9	D8	D7	D6	D5	D4	D3	D2	D1	D0
Content						R_UVW_E	R_UVW_HYS[2:0]	R_UVW_RES[2:0]				

Register Function: This register is used for configuring “UVW output enabling / disabling”, “UVW phase hysteresis”, “the number of UVW pulses per a rotation”.

The register value is duplicated from corresponding memory after power on or, when the mode transferred to "Normal Mode" from “User Mode”.

- a) **UVW output enable configuration:** It is possible to disable the UVW output as necessary. When the ABZ output is set to “inability (0x0)”, the output becomes Hi-Z.

UVW Output State	R_UVW_E	Default
UVW output Inability (Hi-Z output)	0x0	
UVW output	0x1	•

- b) **UVW hysteresis configuration:** This configuration can be used to prevent unexpected UVW pulses under noise influence. Relation between UVW hysteresis and UVW_HYS set value is as following.

UVW Hysteresis	R_UVW_HYS[2:0]	Default
Invalid	0x0	
0LSB	0x1	
1LSB	0x2, 0x5, 0x6, 0x7	•
2LSB	0x3	
3LSB	0x4	

- c) **The number of UVW pulses configuration:** It is possible to set the number of UVW pulses per a rotation by changing following bits according to the number of DCBL motor rotor’s magnetic poles.

The number of UVW pulses	R_UVW_RES[2:0]	Default
1ppr	0x0	
2ppr	0x1	
3ppr	0x2	•
4ppr	0x3	
5ppr	0x4	
6ppr	0x5	
7ppr	0x6	
8ppr	0x7	

● EEPROM Address Map

Table 13. EEPROM Memory Address Map

Addr.[HEX]	Memory symbol	R/W Permission		Note
		Normal Mode	User Mode	
0x00	-	N.A.	N.A.	
0x01	-	N.A.	N.A.	
0x02	-	N.A.	N.A.	
0x03	-	N.A.	N.A.	
0x04	E_ID1	N.A.	R/W	For ID data
0x05	E_ID2	N.A.	R/W	For ID data
0x06	E_ZP	N.A.	R/W	For to set up angle zero point.
0x07	E_RDABZ	N.A.	R/W	For set up "Rotation direction", "Z phase output form", "ABZ output enable/disable", "ABZ Hysteresis" and "ABZ resolution".
0x08	E_MLK	N.A.	R/W	For memory lock
0x09	E_EBDIS	N.A.	R/W	For set up abnormal detection disable
0x0A	E_UVW	N.A.	R/W	For set up "UVW output enable/disable", "UVW Hysteresis" and "UVW resolution".

Note 14. Once set memory lock, this IC cannot be written to any memory.

Note 15. Each register value is duplicated from corresponding memory when the mode transferred to "Normal Mode" or re-power on. In order to reflect a setup data on an output, please return to a normal mode or re-power on.

● Each Memory Configurations

- E_ID1 Memory (Memory Address : 0x04)

E_ID1	D11	D10	D9	D8	D7	D6	D5	D4	D3	D2	D1	D0
Content	E_ID1[11:0]											

Memory Function: This memory can be written as identification information or the lot information by the IC user. Default value is 0x000.

- E_ID2 Memory (Memory Address : 0x05)

E_ID2	D11	D10	D9	D8	D7	D6	D5	D4	D3	D2	D1	D0
Content	E_ID2[11:0]											

Memory Function: This memory can be written as identification information or the lot information by the IC user. Default value is 0x000.

- E_ZP Memory (Memory Address : 0x06)

E_ZP	D11	D10	D9	D8	D7	D6	D5	D4	D3	D2	D1	D0
Content	E_ZP[11:0]											

Memory Function: This memory is available for setting arbitrarily angle position as zero position. Relation between the angle position and the ZP data is the following.

Zero Point Angle Position [°]	E_ZP[11:0]	Default
0	0x000	•
$(360 \div 4096) \times 1$	0x001	
$(360 \div 4096) \times 2$	0x002	
$(360 \div 4096) \times 3$	0x003	
:	:	
$(360 \div 4096) \times 4095$	0xFFFF	

Note 16. A setup of this register and memory is reflected in ABZ and UVW output.

- E_RDABZ Memory (Memory Address : 0x07)

E_RDABZ	D11	D10	D9	D8	D7	D6	D5	D4	D3	D2	D1	D0
Content			E_RD	E_Z_MODE	E_ABZ_E	E_ABZ_HYS[2:0]		E_ABZ_RES[3:0]				

Memory Function: This register is used for configuring “Rotation direction”, “Z phase output form”, “ABZ output enabling / disabling”, “ABZ phase hysteresis” and “ABZ resolution”.

Relation between each bit and setting value is as following.

- a) **Rotation direction configuration:** The output direction can be set in if the angle data increases clockwise or clockwise (Refer to section 16). Relation between the rotation direction and RD is as following.

Rotation Direction	E_RD	Default
CCW (+)	0x0	•
CW (-)	0x1	

- b) **Z phase output form configuration:** The Z phase can be set as either among two modes One is a normal z phase output which carries out toggle at 0 degree position. The other is a switch output which keeps low state in more than 180 degree and high state in less than 180 degree. (Refer to section 14.3)

Z phase output form	E_Z_MODE	Default
Normal output	0x0	•
Switch output	0x1	

- c) **ABZ output enable configuration:** It is possible to disable the ABZ output as necessary. When the ABZ output is set to “inability (0x0)”, the output becomes Hi-Z.

ABZ Output State	E_ABZ_E	Default
ABZ Output Inability (Hi-Z output)	0x0	
ABZ Output	0x1	•

d) **ABZ hysteresis configuration:** This configuration can be used to prevent unexpected ABZ pulses under noise influence. Relation between ABZ hysteresis and ABZ_HYS set value is as following.

ABZ Hysteresis	E_ABZ_HYS[2:0]	Default
Invalid	0x0	
0LSB	0x1	
1LSB	0x2, 0x5, 0x6, 0x7	●
2LSB	0x3	
3LSB	0x4	

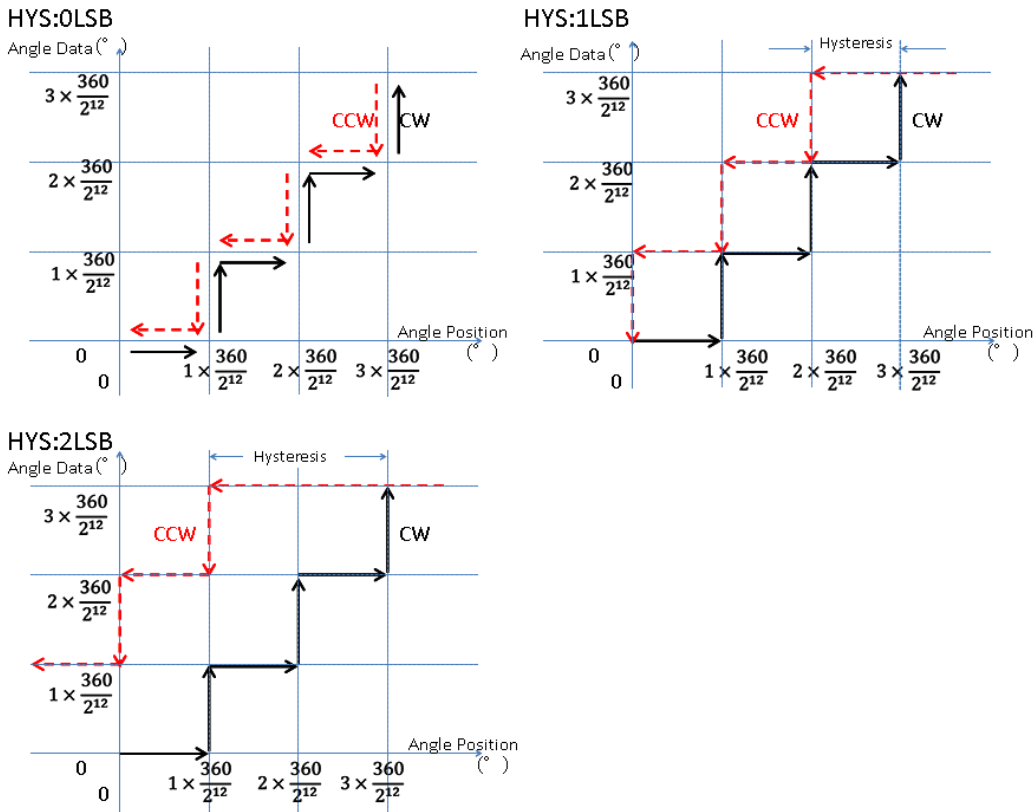

Figure 8. Operational Overview of Hysteresis Configuration

Note 17. As to the difference of ABZ hysteresis between “0LSB” and “Invalid”; Internal angle data always alternates between two adjacent angle data because of the tracking loop characteristics even if the environment is a static condition. In “Invalid” configuration, ABZ output is reflected by internal angle data directly. But in “0LSB” configuration, ABZ output is reflected by internal angle data when internal angle data change over two consecutive LSB in same rotation direction. Thus in this case, LSB bit alternation caused by noise is masked from ABZ output.

- e) **ABZ output resolution configuration:** Able to configure the ABZ resolution by using this configuration. Relation between ABZ resolution and set value is as following.

ABZ phase resolution	ABZ_RES[3:0]	Default
1024ppr	0x0	•
512ppr	0x1	
256ppr	0x2	
128ppr	0x3	
1000ppr	0x4	
900ppr	0x5	
800ppr	0x6	
700ppr	0x7	
600ppr	0x8	
500ppr	0x9	
400ppr	0xA	
360ppr	0xB	
300ppr	0xC	
200ppr	0xD	
100ppr	0xE	
50ppr	0xF	

- E_MLK Memory (Memory Address : 0x08)

E_MLK	D11	D10	D9	D8	D7	D6	D5	D4	D3	D2	D1	D0
Content												E_MLK[1:0]

Memory Function: This configuration is used for locking the memory.

By writing data [0x00] (except for 0x03) in address [0x08], the memory lock is executed. Once the memory is locked, all memory data cannot be changed, and also the memory lock function cannot be released.

Memory Lock State	E_MLK[1:0]	Default
Unlocked	0x3	•
Locked	0x0, 0x1, 0x2	

- E_EBDIS Memory (Memory Address : 0x09)

E_EBDIS	D11	D10	D9	D8	D7	D6	D5	D4	D3	D2	D1	D0
Content												E_EBDIS[1:0]

Memory Function: This memory is used for disabling / enabling each abnormal diagnosis function as necessary. Relation between the diagnosis function and EBDIS is as following. By writing 1 in a corresponding bit, the abnormal diagnosis function is disabled.

Abnormal Diagnosis Parameter	Bit data	Default
Magnetic Flux Density	E_EBDIS[1]	0
Tracking Lost	E_EBDIS[0]	0

- E_UVW Memory (Memory Address : 0x0A)

E_UVW	D11	D10	D9	D8	D7	D6	D5	D4	D3	D2	D1	D0
Content						E_UVW_E	E_UVW_HYS[2:0]			E_UVW_RES[2:0]		

Memory Function: This memory is used for configuring “UVW output enabling / disabling”, “UVW phase hysteresis”, “the number of UVW pulses per a rotation”. Relation between each bit and setting value is as following.

- a) **UVW output enable configuration:** It is possible to disable the UVW output as necessary. When the ABZ output is set to “inability (0x0)”, the output becomes Hi-Z.

UVW Output State	E_UVW_E	Default
UVW output Inability (Hi-Z output)	0x0	
UVW output	0x1	•

- b) **UVW hysteresis configuration:** This configuration can be used to prevent unexpected UVW pulses under noise influence. Relation between UVW hysteresis and UVW_HYS set value is as following.

UVW Hysteresis	E_UVW_HYS[2:0]	Default
Invalid	0x0	
0LSB	0x1	
1LSB	0x2, 0x5, 0x6, 0x7	•
2LSB	0x3	
3LSB	0x4	

- c) **The number of UVW pulses configuration:** It is possible to set the number of UVW pulses per a rotation by changing following bits according to the number of DCBL motor rotor’s magnetic poles.

The number of UVW pulses	E_UVW_RES[2:0]	Default
1ppr	0x0	
2ppr	0x1	
3ppr	0x2	•
4ppr	0x3	
5ppr	0x4	
6ppr	0x5	
7ppr	0x6	
8ppr	0x7	