



Chipsmall Limited consists of a professional team with an average of over 10 year of expertise in the distribution of electronic components. Based in Hongkong, we have already established firm and mutual-benefit business relationships with customers from,Europe,America and south Asia,supplying obsolete and hard-to-find components to meet their specific needs.

With the principle of “Quality Parts,Customers Priority,Honest Operation,and Considerate Service”,our business mainly focus on the distribution of electronic components. Line cards we deal with include Microchip,ALPS,ROHM,Xilinx,Pulse,ON,Everlight and Freescale. Main products comprise IC,Modules,Potentiometer,IC Socket,Relay,Connector.Our parts cover such applications as commercial,industrial, and automotives areas.

We are looking forward to setting up business relationship with you and hope to provide you with the best service and solution. Let us make a better world for our industry!



Contact us

Tel: +86-755-8981 8866 Fax: +86-755-8427 6832

Email & Skype: info@chipsmall.com Web: www.chipsmall.com

Address: A1208, Overseas Decoration Building, #122 Zhenhua RD., Futian, Shenzhen, China





AK7452

Zero Latency Angle Sensor IC

1. General Description

The AK7452 is a monolithic Hall-Effect sensor IC that specializes in detecting rotation angle. A contactless rotary position sensor is easily designed with a magnet.

The AK7452 is only sensitive to the magnetic flux density applied parallel to the IC surface. This is obtained through a magnetic concentrator which is mounted on the Hall-Effect elements. It is advantageous to accurate angular measurements against mechanical displacement.

The AK7452 is the zero latency rotation angle sensor to follow rotation speed up to 25,000rpm by tracking servo architecture. It is suitable for motor controlled applications with an encoder.

2. Applications

Motor Controlled Applications (Robot, Machine tools, Stepping motor, DC brushless motor etc.)
Optical Encoder Replacement

3. Features

- 360° Contactless Angle Sensor
- Simple Magnetic Design
- Extended Industrial Operating Temperature Range : -40°C to +125°C
- Expanded Operating Voltage Range : 3.0 to 5.5V
- Angle Resolution : 14 bit
- Maximum Tracking Rotation Speed : 25,000 rpm
- Angle Linearity Error : $\pm 0.5^\circ$ (@ 25°C)
- Output Propagation Delay : 1.8 μ s (@ ABZ Hysteresis "OFF" setting)
- Self-diagnostic Functions :
 - Under Magnetic Flux Density Detect Function
 - Tracking Lost Detect Function
- Interfaces:
 - 4-wire SPI : Absolute Angle Data & User Programming
 - ABZ Incremental Output
 - UVW Commutation Output
- User Programming Functions
 - Zero Degree Point Setting
 - Magnet Rotation Direction : CCW / CW
 - ABZ Incremental Output Resolution : up to 4096ppr
 - Z-phase Pulse Width : 1LSB / 4LSB / 180deg. Point Switch Mode
 - UVW Commutation Output Resolution : up to 64poles (32 pole pairs)
 - Angle Error Correction
- Environmental Friendly (RoHS Compliant)
 - Lead free
 - Halogen free

4. Table of Contents

1.	General Description.....	1
2.	Applications	1
3.	Features.....	1
4.	Table of Contents	2
5.	Block Diagram and Functional Description	3
6.	Pin Configuration and Functional Description.....	4
7.	Absolute Maximum Ratings.....	5
8.	Operating Conditions.....	5
9.	EEPROM Characteristics	5
10.	Electrical and Magnetic Characteristics	6
11.	Output Electrical Characteristics	7
11.1.	DC Characteristics	7
11.2.	AC Characteristics	7
12.	Serial I/F Digital Characteristics	7
12.1.	DC Characteristics	7
12.2.	AC Characteristics	8
13.	ABZ Incremental Output Description.....	9
14.	UVW Commutation Output Description	10
15.	Programmable Mode Description.....	11
16.	Serial I/F Protocol.....	14
17.	Self-diagnostic Function	17
18.	Register Address Map / Description.....	18
19.	EEPROM Address Map / Description	27
20.	Magnet angle position, output and rotation direction	36
21.	Package Information	37
21.1.	TSSOP16 – Package Dimensions.....	37
21.2.	Marking Information	37
21.3.	Sensitive Spot Positioning	38
22.	Revision History.....	39
	Important Notice	40

5. Block Diagram and Functional Description

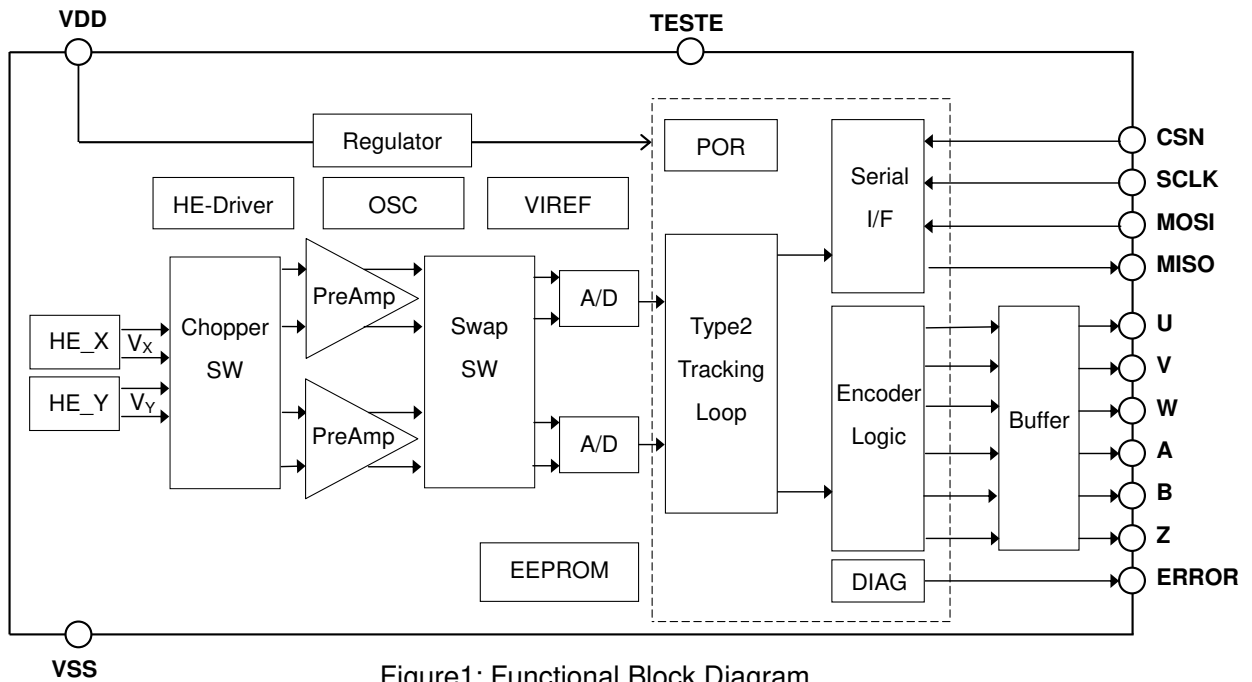

Figure1: Functional Block Diagram

Table1: Functional Block Description

Block name	Function
HE_X / HE_Y	Detect the X/Y-compositions of the magnetic flux density applied parallel to the IC package surface by a magnetic concentrator and convert to electric signal.
Chopper SW	Switch the current direction in order to cancel the Hall elements offset.
PreAmp	Amplify the signals from the Hall elements.
Swap SW	Switch the signal path in order to reduce the error caused by the Hall elements sensitivity mismatch.
A/D	Analog-to-digital converter.
Type2 Tracking Loop	Angle data converter that follows the digitally converted input signal.
Serial I/F	Interface based on 4-wire SPI protocol.
Encoder Logic	Generate the ABZ incremental signal and the UVW commutation signal from the angle data.
DIAG	Self-diagnosis circuit.
POR	Generate a reset signal at the time of low supply voltage.
Buffer	Buffer the output signals.
Regulator	Regulates internal bias voltage.
HE-Driver	Drive the constant current for the Hall elements.
OSC	Generate the master clock.
VIREF	Generate the reference voltage and current.
EEPROM	Non-volatile memory.

6. Pin Configuration and Functional Description

Table2: Pin Configuration and Functional Description

No.	Symbol	I/O	Type	Function
1	U	O	Digital	U-phase Commutation Output Pin
2	V	O	Digital	V-phase Commutation Output Pin
3	W	O	Digital	W-phase Commutation Output Pin
4	NC	-	-	No Connection Pin (Note1)
5	MISO	O	Digital	Serial I/F Data Output Pin
6	MOSI	I	Digital	Serial I/F Data Input Pin
7	SCLK	I	Digital	Serial I/F Clock Input Pin
8	CSN	I	Digital	Serial I/F Chip Select Pin
9	VDD	-	Power	Power Supply Pin
10	NC	-	-	No Connection Pin (Note1)
11	TESTE	I	-	Test Dedicated Pin (Note2)
12	VSS	-	Power	Ground Pin
13	ERROR	O	Digital	Error Output Pin
14	Z	O	Digital	Z-phase Incremental Output Pin
15	B	O	Digital	B-phase Incremental Output Pin
16	A	O	Digital	A-phase Incremental Output Pin

Note1: NC pins must be open.

Note2: TESTE pin must be connected to VSS.

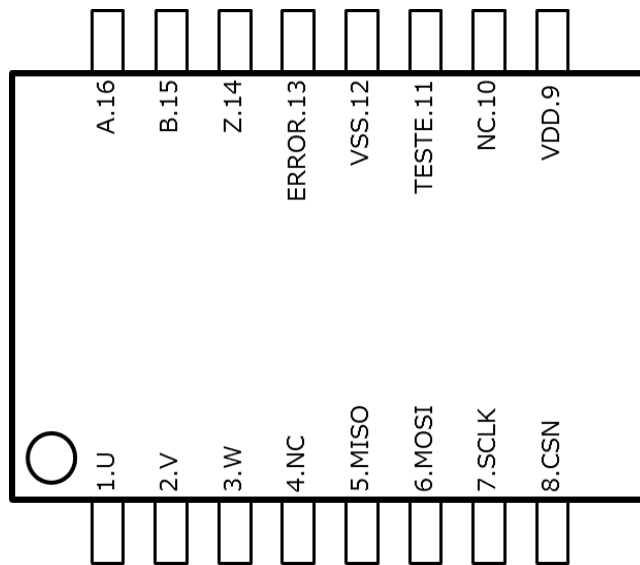

Figure2: Pin Configuration

7. Absolute Maximum Ratings

Parameter	Symbol	Min.	Max.	Unit	Notes
Supply Voltage	V_{DDA}	-0.3	+6.5	V	VDD pin
Terminal Voltage	V_{TERM}	-0.3	V_{DD}	V	U, V, W, MISO, MOSI, SCLK, CSN, TESTE, ERROR, Z, B, A, NC pin
Output Current	I_{OA}	-10	+10	mA	U, V, W, MISO, ERROR, Z, B, A pin
Storage Temperature	T_{STG}	-50	+150	°C	

WARNING: Operation beyond these limits may cause permanent damage to the device. Even if it does not lead to destruction, reliability and life may be adversely affected. Normal operation is not guaranteed at these extremes. Each voltage is with respect to VSS pin.

8. Operating Conditions

Parameter	Symbol	Min.	Typ.	Max.	Unit	Notes
Supply Voltage	V_{DD}	3.0	5.0	5.5	V	VDD pin
Operating Ambient Temperature	T_a	-40	25	+125	°C	

WARNING: Electrical and magnetic characteristics are not guaranteed when operated beyond these conditions. Each voltage is with respect to VSS pin.

9. EEPROM Characteristics

($V_{DD}=3.0$ to $5.5V$)

Parameter	Symbol	Min.	Typ.	Max.	Unit	Notes
EEPROM Endurance	E_{en}			1000	Cycle	This parameter is guaranteed by design.
Ambient Temperature in Writing	T_{aw}	0		+85	°C	
Writing Time	W_t			5	ms	

10. Electrical and Magnetic Characteristics
--

($T_a = -40$ to $+125$ °C, $V_{DD} = 3.0$ to 5.5 V unless otherwise specified)

Parameter	Symbol	Conditions	Min.	Typ.	Max.	Unit
Magnetic Flux Density Range	B_{RANGE}		30	50	70	mT
Angle Detection Range	A_{RANGE}		0		360	deg.
Angle Resolution	A_{RES}			0.022		deg.
Angle Tracking Rate	T_{RA}				25000	rpm
Angle Linearity Error	A_{INL}	$T_a = 25^\circ\text{C}$	-0.5		+0.5	deg.
Angle Hysteresis	A_{HYS}	$T_a = 25^\circ\text{C}$			0.3	deg.
Thermal Angle Drift (Note3)	A_{DRIFT}	$T_a = 25^\circ\text{C}$ basis	-0.5		+0.5	deg.
Angle Output Noise	A_{NOISE}	$\pm 3.3\sigma$	-1		+1	LSB
Angle Output Delay (Note4)	T_D	ABZ Hysteresis "OFF" setting			1.8	μs
Supply Current	I_{DD}	No output load			20	mA
Startup Time (Note5)	T_{START}				40	ms

Note3: This parameter is derived from IC design and not tested at mass production.

Note4: This parameter changes as follows when the ABZ output hysteresis setting is not OFF.

Output Delay (max) : $T_D = 1.8\mu\text{s} + (1 + \text{"ABZ Hysteresis"}) \cdot 0.18\mu\text{s}$

Note5: Startup time is defined as the time from when VDD reaches operating voltage level to when the ERROR pin is set to "H" level.

11. Output Electrical Characteristics

11.1. DC Characteristics

($T_a = -40$ to $+125^\circ\text{C}$, $V_{DD} = 3.0$ to 5.5V unless otherwise specified)

Parameter	Symbol	Conditions	Min.	Typ.	Max.	Unit
Output Current	I_{OUT}	U, V, W, ERROR, Z, B, A pin	-2		+2	mA
Output Low Level	V_{OL}	U, V, W, ERROR, A, B, A pin $I_{OUT} = 2\text{mA}$ (sink)			$0.2V_{DD}$	V
Output High Level	V_{OH}	U, V, W, ERROR, Z, B, A pin $I_{OUT} = 2\text{mA}$ (source)	$0.8V_{DD}$			V
Output Load Capacitance	C_{OUT}	U, V, W, ERROR, Z, B, A pin			50	pF

11.2. AC Characteristics

($T_a = -40$ to $+125^\circ\text{C}$, $V_{DD} = 3.0$ to 5.5V unless otherwise specified)

Parameter	Symbol	Conditions	Min.	Typ.	Max.	Unit
Output Rise Time	T_{RO}	U, V, W, ERROR, Z, B, A pin $I_{OUT} = 2\text{mA}$ (source)			30	ns
Output Fall Time	T_{FO}	U, V, W, ERROR, Z, B, A pin $I_{OUT} = 2\text{mA}$ (sink)			30	ns

12. Serial I/F Digital Characteristics

12.1. DC Characteristics

($T_a = -40$ to $+125^\circ\text{C}$, $V_{DD} = 3.0$ to 5.5V unless otherwise specified)

Parameter	Symbol	Conditions	Min.	Typ.	Max.	Unit
Input Current	I_{SI}	MOSI, SCLK, CSN pin	-10		+10	μA
Input Low Level	V_{LSI}	MOSI, SCLK, CSN pin			$0.3V_{DD}$	V
Input High Level	V_{HSI}	MOSI, SCLK, CSN pin	$0.7V_{DD}$			V
Output Current	I_{SO}	MISO pin	-700		+700	μA
Output Low Level	V_{LSO}	MISO pin $I_{SO} = 700\mu\text{A}$ (sink)			$0.2V_{DD}$	V
Output High Level	V_{HSO}	MISO pin $I_{SO} = 700\mu\text{A}$ (source)	$0.8V_{DD}$			V
Output Load Capacitance	C_{SO}	MISO pin			50	pF

12.2. AC Characteristics

($T_a = -40$ to $+125^\circ\text{C}$, $V_{DD} = 3.0$ to 5.5V unless otherwise specified)

Parameter	Symbol	Conditions	Min.	Typ.	Max.	Unit
SCLK Frequency	F_{SCLK}		0.001		8000	kHz
	F_{SCLKRE}	@ReadEEPROM OPCODE (Note6)	0.001		100	kHz
SCLK High Time	T_H		50			ns
	T_{HRE}	@ReadEEPROM OPCODE	4			μs
SCLK Low Time	T_L		50			ns
	T_{LRE}	@ReadEEPROM OPCODE	4			μs
SCLK Rise Time	T_R	Not tested at mass production			10	ns
SCLK Fall Time	T_F	Not tested at mass production			10	ns
Data Output Rise Time	T_{RDO}				20	ns
Data Output Fall Time	T_{FDO}				20	ns
CS Setup Time	T_{CSS}		100			ns
CS Hold Time	T_{CSH}		100			ns
Data Setup Time	T_{DS}		20			ns
Data Hold Time	T_{DH}		20			ns
Data Valid Time	T_{DV}				50	ns
Data Release Time	T_{DR}				100	ns
Wait Time	T_{CW}	@ReadAngle OPCODE	200			ns
	T_{EW}	@WriteEEPROM OPCODE	5			ms
	T_{RW}	@WriteReg OPCODE	2.5			μs
	T_{MT}	@ChangeMode OPCODE (User Mode to Normal Mode) (User Mode2 to Normal Mode)	40			ms
		@ChangeMode OPCODE (Normal Mode to User Mode) (User Mode to User Mode2) (User Mode2 to User Mode)	1			ms

Note6: The ReadEEPROM operation needs to operate at F_{SCLKRE} or lower clock frequency. Operation beyond this limit may cause malfunction of reading out.

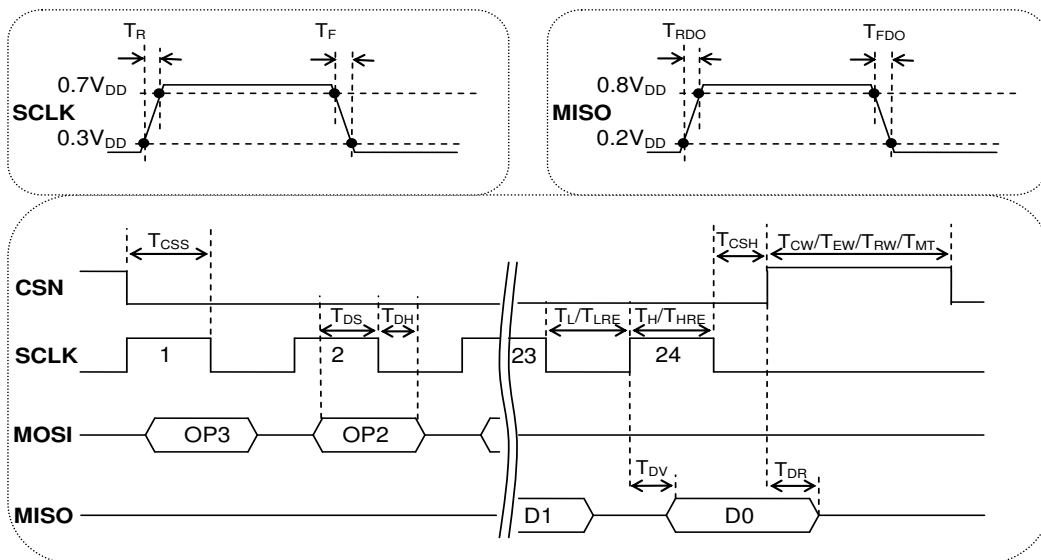

Figure3: Serial I/F AC Characteristics

13. ABZ Incremental Output Description

The AK7452 provides the ABZ incremental output via A, B, Z pin. These outputs are encoded from the angle output data. The output resolution is programmable between 1 and 4096ppr. When the magnet is rotating in counter-clockwise at default settings, the B-phase leads the A-phase. The Z-phase width is selectable among “Z-width 1LSB mode”, “Z-width 4LSBmode” and “180deg. point switch mode”.

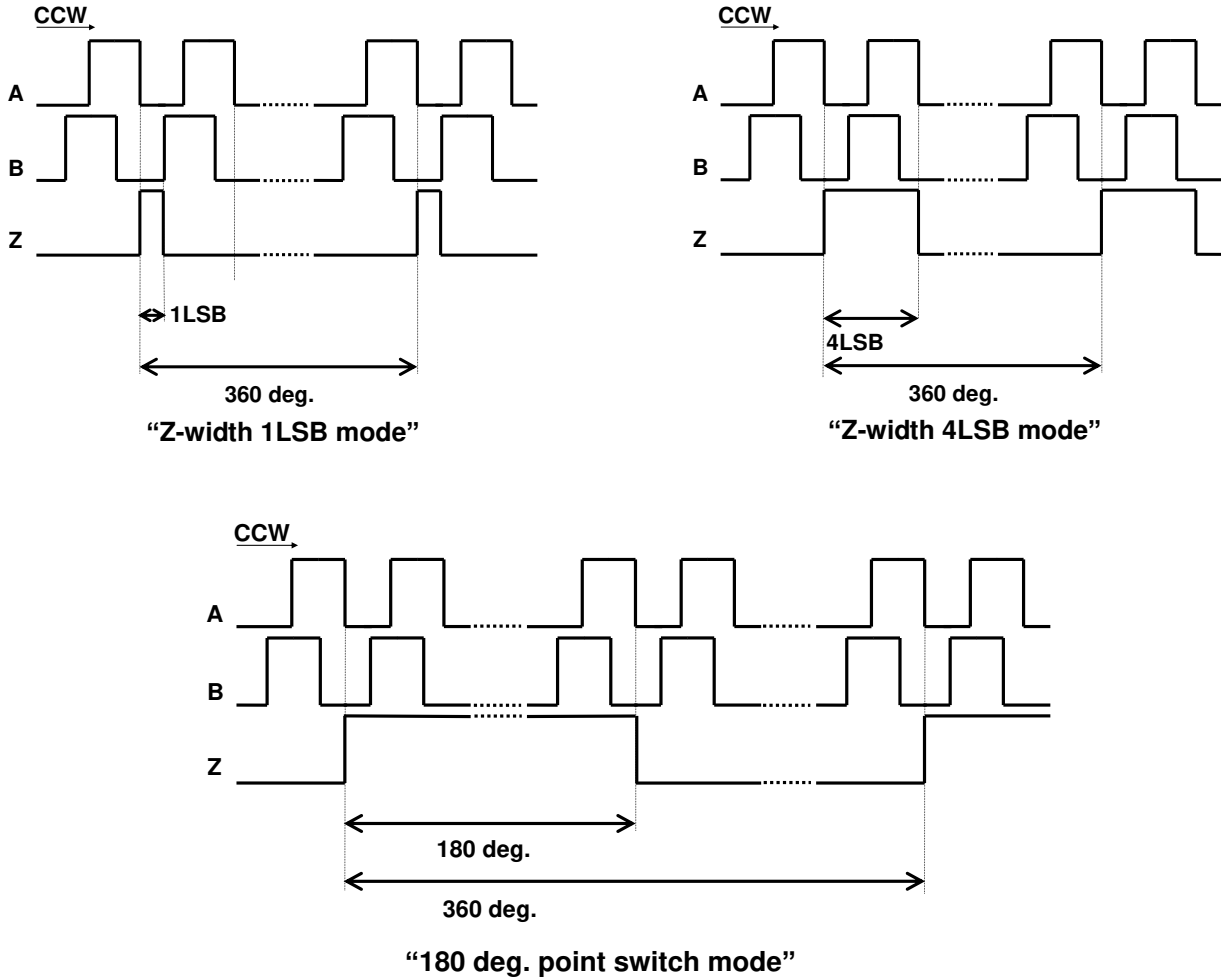

Figure4: ABZ Incremental Output Characteristics

14. UVW Commutation Output Description

The AK7452 provides the UVW commutation output necessary for detecting the magnetic pole of the DC brushless motor via U, V, W pin. The phase of each output is shifted by electric angle phase 120°. The output resolution is programmable from 2 to 64 poles (1 to 32 pole pairs).

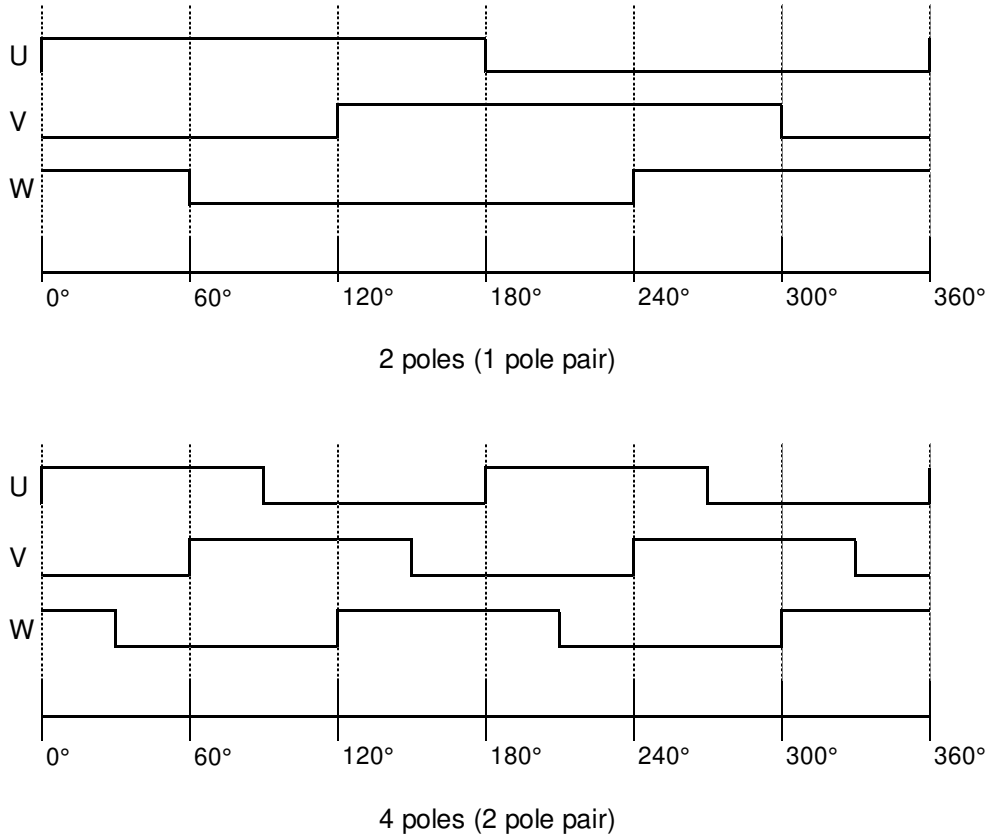

Figure5: UVW Commutation Output

15. Programmable Mode Description

The AK7452 has the three modes (Normal Mode, User Mode and User Mode2). In Normal mode, ABZ incremental output and UVW output are obtained, and angle data can be read by serial interface. In User Mode and User Mode2, it is able to read and write the internal registers and EEPROM according to a serial I/F. User Mode supports the user programming such as zero point adjustment, magnet rotation direction, ABZ incremental output resolution, Z-phase output setting, UVW commutation output resolution, output hysteresis, output ON/OFF setting, self-diagnostic ON/OFF setting and EEPROM Memory lock setting. Additionally User Mode2 supports the angle error correction settings. When the power supply is turned ON, the AK7452 automatically resets the internal register and loads the EEPROM configuration data to set the internal configuration register. After startup sequence, the AK7452 operates in Normal Mode.

➤ **Mode Description**

Each mode can be changed by writing a specific OPCODE and DATA on a specific address as the diagram below.

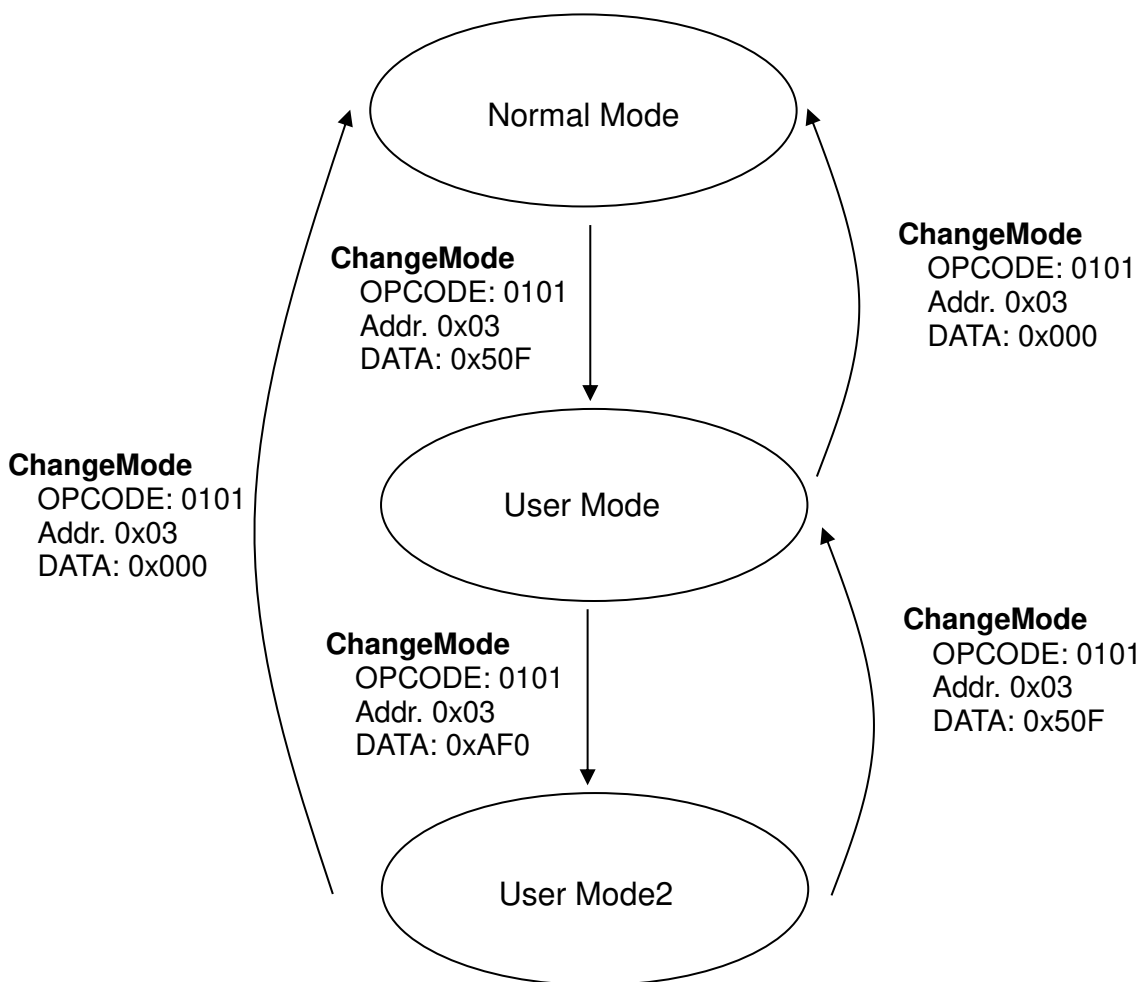

Figure6: Mode Transition Diagram

Table3: Mode Description

Mode Name	Note
Normal Mode	<p>In Normal Mode, it is not able to access the internal register and EEPROM except register R_ANG_H (Addr.0x00), R_ANG_L (Addr.0x01) and register R_CHMD (Addr.0x03). Available operation codes are ReadAngle and ChangeMode. The ABZ Incremental outputs and UVW commutation outputs are toggled corresponding to the magnet rotation.</p> <p>When various self-diagnosis functions are detected, AK7452 automatically notifies the diagnostic state by the ERROR pin and the error bit attached to the angle data output from the serial interface.</p> <p>In case of changing mode to Normal Mode, all registers are automatically initialized and loads the EEPROM configuration data to set the internal configuration register. Therefore the wait time interval for the normal operating condition needs to be equal to wait time T_{MT} or longer.</p>
User Mode	<p>In User Mode, it is able to access the internal configuration register and EEPROM. To set the following parameters in Normal Mode, configuration data need to be stored in EEPROM.</p> <ol style="list-style-type: none"> 1. Zero Degree Point Setting This setting defines the origin of the output angle data. It is programmable at any angle position in 14-bit resolution. 2. Magnet Rotation Direction Setting This setting defines the increase or decrease of the output angle data relative to the magnet rotation direction. When it is selected to "CCW", the output angle data increases in response to counter-clockwise direction magnet rotation. When it is selected to "CW", the output angle data increases in response to clockwise direction magnet rotation. 3. Z-phase Pulse Width Setting This setting defines the Z-phase pulse width in the ABZ incremental output. Z phase pulse width can be selected from 1LSB or 4LSB of ABZ incremental output resolution setting and switch mode. Switch mode outputs "H" level at 0° to 180° position and "L" level at 180° to 360° position. 4. ABZ Incremental Output ON/OFF Setting This setting defines these outputs setting to enable or disable. When it is selected to "OFF", the A, B and Z pin go to high-impedance (Hi-Z) output. 5. ABZ Incremental Output Hysteresis Setting This setting defines the ABZ hysteresis parameter. The ABZ output is not updated when the processing data step is smaller than the programmed parameter. 6. ABZ Incremental Output Resolution Setting This setting defines the ABZ output resolution. It is programmable to an arbitrary value from 1 to 4096ppr. 7. Memory Lock Setting In order to prevent rewriting EEPROM incorrectly, it is able to lock the memory. Once the configuration of memory lock is enabled, it is not possible to change EEPROM anymore.

	<p>8. Self-diagnostic ON/OFF Setting This setting defines the activation or inactivation of each self- diagnostic functions.</p> <p>9. UVW Commutation Output ON/OFF Setting This setting defines these outputs setting to enable or disable. When it is selected to “OFF”, the U, V and W pin go to high-impedance (Hi-Z) output.</p> <p>10. UVW Commutation Output Hysteresis Setting This setting defines the UVW output hysteresis parameter. The UVW output is not updated when the processing data step is smaller than the programmed parameter.</p> <p>11. UVW Commutation Output Resolution Setting This setting defines the UVW output resolution. It is programmable to an arbitrary value from 2 to 64poles (1~32 pole pairs).</p> <p>In User Mode, the ERROR pin goes to “L” level output. In User Mode, the angle data, the magnetic flux density data and self-diagnostic data are not updated automatically. To check the latest processing data, DataRenewal operation code needs to be sent in advance (Typ.135μs).</p> <p>In case of changing mode to User Mode, all registers are automatically initialized. Therefore the wait time interval for the normal operating condition needs to be equal to wait time T_{MT} or longer.</p> <p>WARNING: Electrical and magnetic characteristics are not guaranteed in User Mode.</p>
User Mode2	<p>In User Mode2, it is also able to access the internal configuration EEPROM. In addition to the access area of User Mode, User Mode2 supports the angle error correction settings as below. To set the following parameters in Normal Mode, configuration data need to be stored in EEPROM.</p> <ol style="list-style-type: none"> 1. Offset Adjustment Setting This setting defines the correction setting for the X-axis and Y-axis offset error. 2. Orthogonality Adjustment Setting This setting defines the correction setting for the orthogonality error between X-axis and Y-axis. 3. Gain Mismatch Adjustment Setting This setting defines the correction setting for the gain mismatch between X-axis and Y-axis. <p>To change these settings, Please refer “AK7452 Application Note for User Mode2”. In case of changing these parameters, AKM recommends the initial setting parameters are copied to your back up area in advance for setting recovery.</p> <p>WARNING: These setting parameters are trimmed at our factory for ideal shaft-end mounting. In case of changing these parameters, the electrical and magnetic characteristics are not guaranteed in Normal Mode. WARNING: Electrical and magnetic characteristics are not guaranteed in User Mode2.</p>

16. Serial I/F Protocol

The AK7452 provides the 4-wire SPI for user programming. Data communication is available only when the CSN pin set to "L". To write the internal register or EEPROM, serial data must be input via the MOSI pin on the falling edge of SCLK. To read the internal register or EEPROM, the AK7452 outputs serial data via the MISO pin on the rising edge of SCLK.

➤ **OPCODE**

Table4: Operation Code Description

OPCODE [3:0]	Code name	Description	Permission		
			Normal Mode	User Mode	User Mode2
0000	N/A	N/A	invalid	invalid	invalid
0001	WriteEEPROM	Store data to EEPROM	invalid	valid	valid
0010	ReadEEPROM	Read data from EEPROM	invalid	valid	valid
0011	WriteReg	Store data to the internal register	invalid	valid	valid
0100	ReadReg	Read the internal register data	invalid	valid	valid
0101	ChangeMode	Change operating mode	valid	valid	valid
0110	N/A	N/A	invalid	invalid	invalid
0111	N/A	N/A	invalid	invalid	invalid
1000	DataRenewal	Update the processing data	invalid	valid	valid
1001	ReadAngle	Read the angle data	valid	valid	valid
1010	<i>AKM Reserved</i>	<i>AKM Reserved</i>	invalid	invalid	<i>AKM Use Only</i>
1011	N/A	N/A	invalid	invalid	invalid
1100	N/A	N/A	invalid	invalid	invalid
1101	N/A	N/A	invalid	invalid	invalid
1110	N/A	N/A	invalid	invalid	invalid
1111	N/A	N/A	invalid	invalid	invalid

➤ **Data sequence**

1) Write data

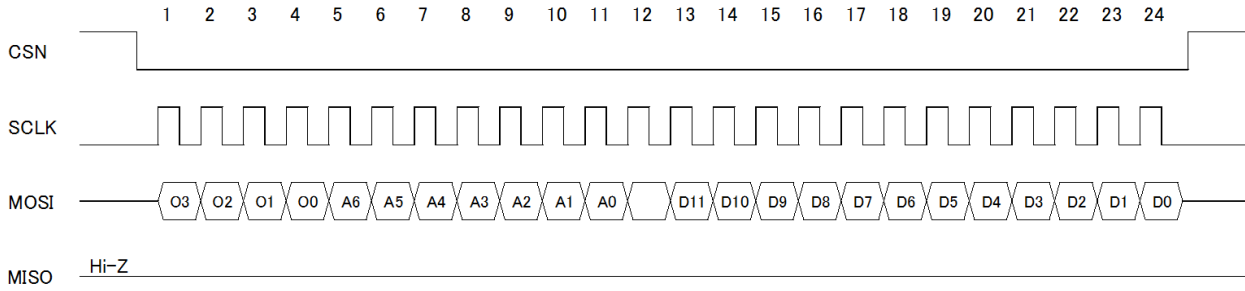

OPCODE(O[3:0])=0001(Write data to EEPROM)
 OPCODE(O[3:0])=0011(Write data to Register)
 A[6:0]:Register or EEPROM address
 D[11:0]:Writing data

2) Read Data

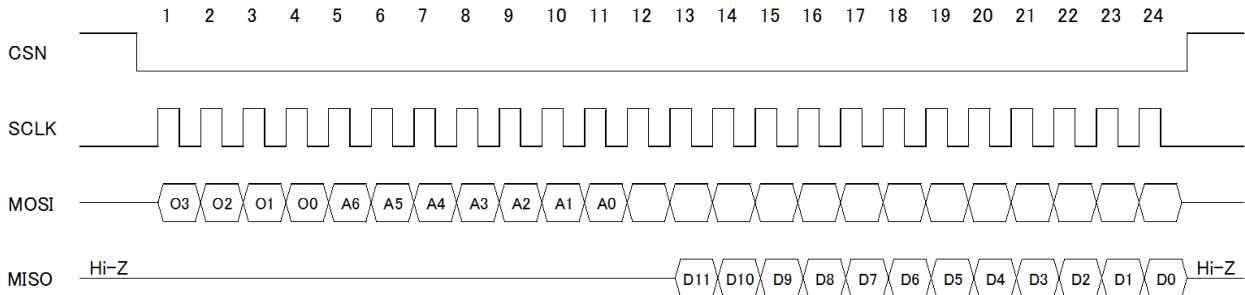

OPCODE(O[3:0])=0010(Read data from EEPROM)
 OPCODE(O[3:0])=0100(Read data from Register)
 A[6:0]:Register or EEPROM address
 D[11:0]:Reading data

3) Change Mode

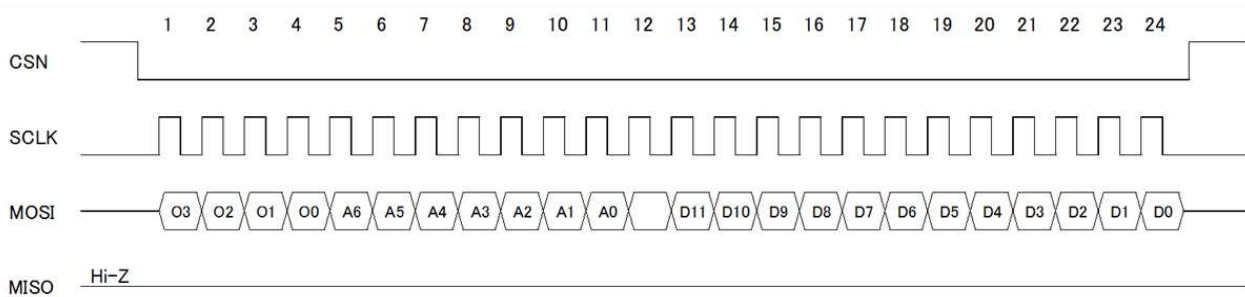

OPCODE(O[3:0])=0101
 A[6:0]:0x03
 D[11:0]:“0x000”(Normal Mode), “0x50F”(User Mode), “0xAF0”(User Mode2)

4) Data Renewal

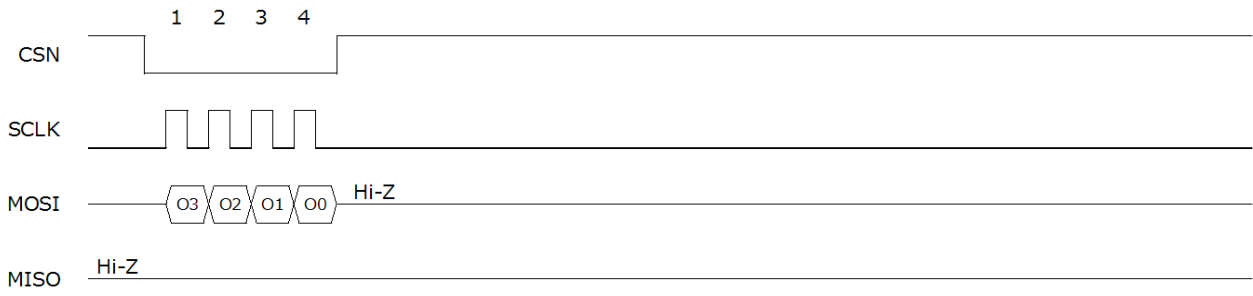

OPCODE(O[3:0])=1000

5) Read Angle

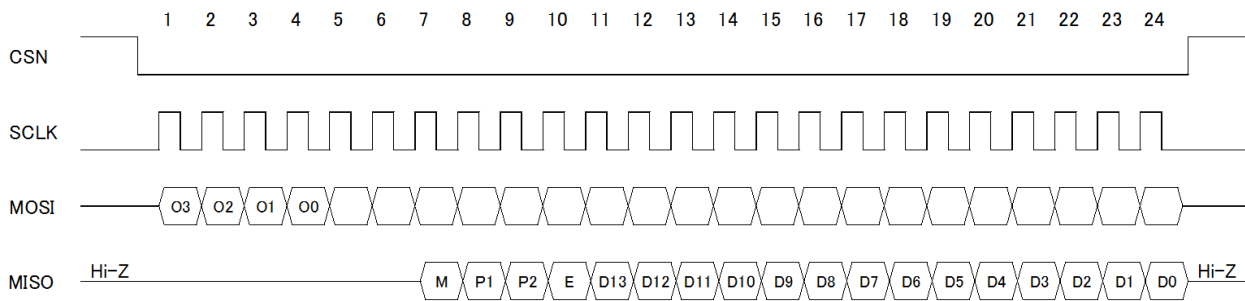

OPCODE(O[3:0])=1001

- M: Mode bit ("0" indicates Normal Mode, "1" indicates User Mode or User Mode2)
- P1: Parity bit for R_ANG[13:7] and Error bit (Normal: ODD Parity, Error: EVEN Parity)
- P2: Parity bit for R_ANG[6:0] and Error bit (Normal: ODD Parity, Error: EVEN Parity)
- E: Error bit (Normal=1, Error=0)
- D[13:0]:14bit angle data (R_ANG_U[1:0], R_ANG_L[11:0])

17. Self-diagnostic Function

The AK7452 has several self-diagnostic functions to detect a condition when magnetic flux density applied to the AK7452 is poor and a condition of loss of tracking. In User Mode, each diagnostic function can be disabled but it is strongly recommended to enable all diagnostic functions for establishing a robust system.

➤ **Under Magnetic Flux Density Detection**

The AK7452 indicates an error when the magnetic flux density is undersupplied (Typ. under 17.2mT). This error sets the ERROR pin to “L” level and error bit to “0”.

➤ **Loss of Tracking Detection**

The AK7452 indicates an error when there is a loss of tracking (Typ. over 2°). This error sets the ERROR pin to “L” level and error bit to “0”.

In case of no error by diagnosis, the AK7452 returns the ERROR pin to “H” level and error bit to “1” automatically.

18. Register Address Map / Description

➤ **Register Address Map**

Address	Register Name	Permission			Content
		Normal Mode	User Mode	User Mode2	
0x00	R_ANG_U[1:0]	R	R	R	14-bit Angle Data (Upper 2-bit)
0x01	R_ANG_L[11:0]	R	R	R	14-bit Angle Data (Lower 12-bit)
0x02	R_MAG[9:0]	N/A	R	N/A	Magnetic Flux Density Data
0x03	R_CHMD[11:0]	W	R/W	R/W	Mode Indicator Data
0x04	R_ERRMON[1:0]	N/A	R	R	Diagnosis Error Monitor
0x05	R_ZP_U[1:0]	N/A	R/W	R/W	14-bit Zero Degree Point Setting (Upper 2-bit)
0x06	R_ZP_L[11:0]	N/A	R/W	R/W	14-bit Zero Degree Point Setting (Lower 12-bit)
0x07	R_RDABZ[7:0]	N/A	R/W	R/W	Rotation Direction Setting Z-phase Pulse Width Setting ABZ Output ON/OFF Setting ABZ Output Hysteresis Setting
0x08	R_ABZRES[11:0]	N/A	R/W	R/W	ABZ Output Resolution Setting
0x09	R_MLK[1:0]	N/A	R	R	Memory Lock Indicator
0x0A	R_SDDIS[1:0]	N/A	R/W	R/W	Self-diagnostic ON/OFF Setting
0x0B	R_UVW[9:0]	N/A	R/W	R/W	UVW Output ON/OFF Setting UVW Output Hysteresis Setting UVW Output Resolution Setting

(N/A: not available, R: read only, W: write only, R/W: full access)

➤ **Register description**

1) **R_ANG_U, R_ANG_L (Addr.0x00, 0x01)**

(Addr.0x00) DATA[11:0]											
11	10	9	8	7	6	5	4	3	2	1	0
										R_ANG_U[1:0]	

(Addr.0x01) DATA[11:0]											
11	10	9	8	7	6	5	4	3	2	1	0
R_ANG_L[11:0]											

These registers contain the output 14-bit angle data improved by the hysteresis filter. The hysteresis filter is applied to the processed raw angle data according to the ABZ hysteresis setting. In Normal Mode, the output angle data can be read via ReadAngle operation code.

The relationship between data value and angular position are as follows.

Angular position[°]	R_ANG_U[1:0]	R_ANG_L[11:0]
0	0x0	0x000
0.022	0x0	0x001
0.044	0x0	0x002
0.066	0x0	0x003
▪	▪	▪
89.978	0x0	0xFFF
90.000	0x1	0x000
▪	▪	▪
359.956	0x3	0xFFE
359.978	0x3	0xFFF

2) R_MAG (Addr.0x02)

(Addr.0x02) DATA[11:0]											
11	10	9	8	7	6	5	4	3	2	1	0
-											R_MAG[9:0]

These registers contain the 10-bit magnetic flux density data. The data resolution is 0.14mT/LSB(Typ). In User Mode, the magnetic flux density can be detected by reading these registers. When fabricating a rotary position sensor module designed with a magnet, it is able to check the magnetic flux density whether targeted magnetic field strength is applied or not.

The relationship between data value and angular position are as follows.

Magnetic flux density [mT]	R_MAG[9:0]
0	0x000
0.14	0x001
0.28	0x002
0.42	0x003
▪	▪
143.22	0x3FF

WARNING: This magnetic flux density measurement data's accuracy which is stored in this register is not guaranteed. It is recommended to use for only reference.

3) R_CHMD (Addr.0x03)

(Addr.0x03) DATA[11:0]											
11	10	9	8	7	6	5	4	3	2	1	0
R_CHMD[11:0]											

These registers contain the 12-bit mode indication data. In Normal mode, mode change can be done by using ChangeMode opcode and storing instruction data in R_CHMD register.

Mode	R_CHMD[11:0]	Default
Normal Mode	0x000	●
User Mode	0x50F	
User Mode2	0xAF0	

Note7: It is not possible to make a direct transition from Normal Mode to User Mode2. Transition to User Mode2 must be executed in User Mode.

4) R_ERRMON (Addr.0x04)

(Addr.0x04) DATA[11:0]											
11	10	9	8	7	6	5	4	3	2	1	0
-										R_ERR MON[1:0]	

These registers contain the diagnostic indication data. In case of diagnosis, each indication data bit is set to "0". The relationship between each item and bits are as follows.

R_ERRMON [1:0]	Diagnosis	Value when detected	Normal Value
R_ERRMON[1]	Under Magnetic Flux Density Detection	0	1
R_ERRMON[0]	Loss of Tracking Detection	0	1

5) R_ZP_U, R_ZP_L (Addr.0x05, 0x06)

(Addr.0x05) DATA[11:0]											
11	10	9	8	7	6	5	4	3	2	1	0
-										R_ZP_U[1:0]	

(Addr.0x06) DATA[11:0]											
11	10	9	8	7	6	5	4	3	2	1	0
R_ZP_L[11:0]											

These registers contain the configuration data of zero degree point. This data is used as a reference of the output angle data.

Zero Degree Point[°]	R_ZP_U[1:0]	R_ZP_L[11:0]	Default
0	0x0	0x000	•
0.022	0x0	0x001	
0.044	0x0	0x002	
0.066	0x0	0x003	
▪	▪	▪	
89.978	0x0	0xFFF	
90.000	0x1	0x000	
▪	▪	▪	
359.956	0x3	0xFFE	
359.978	0x3	0xFFF	

Note8: The value set in this register is also reflected in ABZ and UVW output.

6) R_RDABZ (Addr.0x07)

(Addr.0x07) DATA[11:0]											
11	10	9	8	7	6	5	4	3	2	1	0
-				R_RD	R_Z_WIDTH[1:0]		R_ABZ_E	R_ABZ_HYS[3:0]			

These registers contain the configuration data of rotation direction, Z-phase pulse width, ABZ incremental output ON/OFF and ABZ incremental output hysteresis.

6-1. R_RD Register

R_RD register contains the configuration data of magnet rotation direction. It defines the increase or decrease of the output angle data relative to the magnet rotation direction.

In case of selecting CCW (counter-clockwise), the output angle data increases in response to counter-clockwise magnet rotation. Counter-clockwise is defined by the 1-8-9-16 pin order direction for TSSOP-16 package top view position.

In case of selecting CW (clockwise), the output angle data increases in response to clockwise magnet rotation. Clockwise is defined by the 16-9-8-1 pin order direction for TSSOP-16 package top view position.

Rotation Direction	R_RD	Default
CCW	0x0	•
CW	0x1	

6-2. R_Z_WIDTH Register

R_Z_WIDTH register stores Z phase pulse width setting data. In any setting, the Z phase output generates pulse at the 0° position.

In “Z-width 1 LSB mode” setting, the Z-phase pulse width is quarter of one cycle of A phase.

In “Z-width 1 LSB mode” setting, the Z-phase pulse width is equal to one cycle of A phase.

In “180 deg. Point switch mode” setting, the Z phase outputs “H” level from the 0° position to the 180° position and “L” level from the 180° position to the 360° position.

Z-phase Output	R_Z_WIDTH	Default
Z-width 1LSB mode	0x0	
180 deg. point switch mode	0x1	
Z-width 4LSB mode	0x2	•
180 deg. point switch mode	0x3	

6-3. R_ABZ_E Register

R_ABZ_E register contains the configuration data of ABZ incremental output ON/OFF.

In case of “OFF” setting, the A, B, Z pin goes to high-impedance (Hi-Z) output.

ABZ Output	R_ABZ_E	Default
OFF	0x0	
ON	0x1	•

6-4. R_ABZ_HYS Register

R_ABZ_HYS registers contain the configuration data of hysteresis filter parameter.

This parameter defines whether the output angle data is updated or not in response to the processing raw angle data change. The output angle data is not updated when the processing raw angle data change is smaller than the hysteresis width. This parameter is defined in units of 1 LSB of 14bit angle data.

When the hysteresis width is increased, the data oscillation influence caused by noisy environment and/or module vibration is decreased. However the maximum output delay is increased as described below equation.

$$\text{Maximum Output Delay } T_D = 1.8\mu\text{s} + (1 + \text{“ABZ Hysteresis”}) \cdot 0.18\mu\text{s}$$

Note9: “ABZ Hysteresis” in the above expression is the number of LSB set by R_ABZ_HYS [3:0].
 (Example: “ABZ Hysteresis” = 3 when R_ABZ_HYS [3:0] = 0x4.)

In case of “OFF” setting, the output angle data equals the processing raw angle data. The inherent LSB data flickering (Note10) is not eliminated from the output angle data. The maximum output delay is the shortest (1.8μs) at this setting.

In case of “0LSB” setting, the inherent LSB data flickering is eliminated from the output angle data. The maximum output delay is 1.98μs at this setting.

Note10: The LSB data flickering inheres in the type2 tracking loop architecture. This data flickering appears even in the ideal environment under noise free case. Therefore AKM do not recommend “OFF” setting.

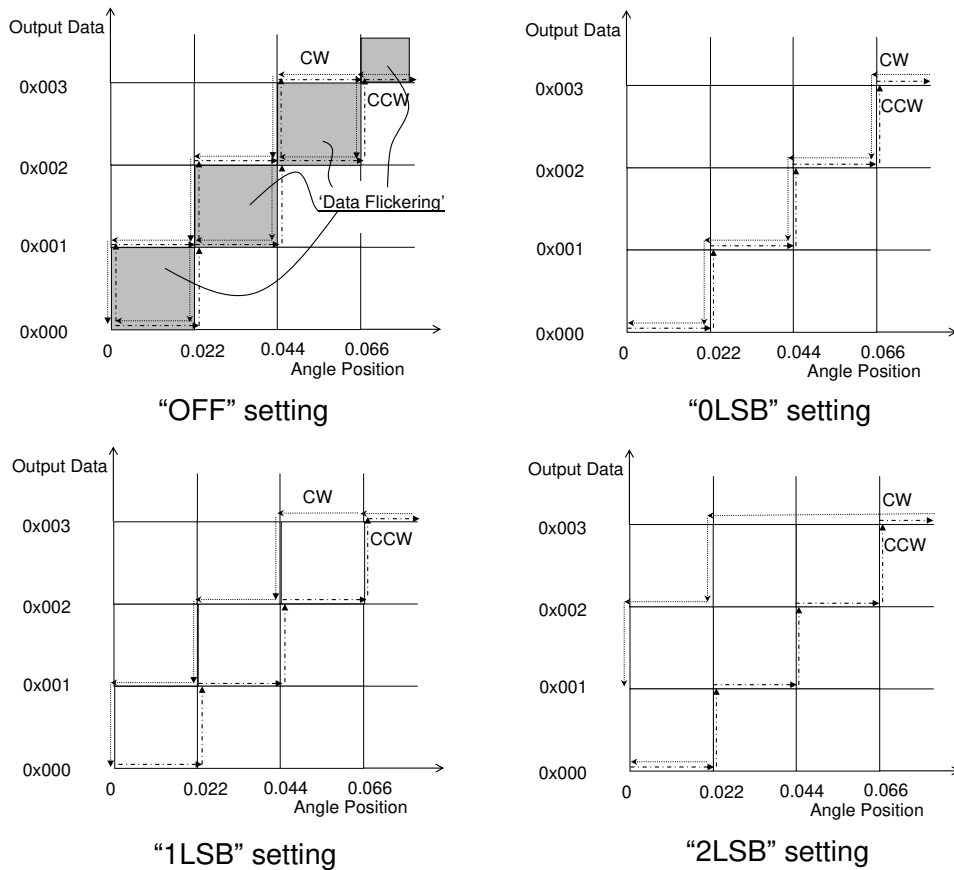

Figure7: ABZ Hysteresis Setting Diagram

The relationship between R_ABZ_HYS[3:0] and the hysteresis set value are as follows.

ABZ Hysteresis	R_ABZ_HYS[3:0]	Default
OFF	0x0	
0LSB	0x1	
1LSB	0x2	•
2LSB	0x3	
3LSB	0x4	
4LSB	0x5	
5LSB	0x6	
6LSB	0x7	
7LSB	0x8	
8LSB	0x9	
9LSB	0xA	
10LSB	0xB	
11LSB	0xC	
12LSB	0xD	
OFF	0xE	
OFF	0xF	

7) R_ABZRES (Addr.0x08)

(Addr.0x08) DATA[11:0]											
11	10	9	8	7	6	5	4	3	2	1	0
R_ABZRES[11:0]											

These registers contain the configuration data of ABZ incremental output resolution. It can be set to an arbitrary value from 1 to 4096ppr.

ABZ Resolution	R_ABZ_RES[11:0]	Default
1ppr	0x000	
2ppr	0x001	
▪	▪	
1000ppr	0x3E7	
▪	▪	
2500ppr	0x9C3	•
▪	▪	
4095ppr	0xFFE	
4096ppr	0xFFF	

8) R_MLK (Addr.0x09)

(Addr.0x09) DATA[11:0]											
11	10	9	8	7	6	5	4	3	2	1	0
										R_MLK[1:0]	

These registers contain the 2-bit memory indication data. To check the memory condition, R_MLK can be read via ReadReg operation code in User Mode.

Memory Condition	R_MLK[1:0]	Default
Locked	0x0	
Locked	0x1	
Locked	0x2	
Unlocked	0x3	●

9) R_SDDIS (Addr.0x0A)

(Addr.0x0A) DATA[11:0]											
11	10	9	8	7	6	5	4	3	2	1	0
										R_SDDIS[1:0]	

These registers contain the configuration data for the self-diagnostic functions. To disable a specific diagnostic function, the corresponding bit should be set to "1".

R_SDDIS[1:0]	Description	Default
R_SDDIS[1]	Low magnetic field state detection	0
R_SDDIS[0]	Loss of Tracking Detection	0

10) R_UVW (Addr.0x0B)

(Addr.0x0B) DATA[11:0]											
11	10	9	8	7	6	5	4	3	2	1	0
		R_UVW_E	R_UVW_HYS[3:0]			R_UVW_RES[4:0]					

These registers contain the configuration data of UVW commutation output ON/OFF, UVW commutation output hysteresis and UVW commutation output resolution.

10-1. R_UVW_E Register

R_UVW_E register contains the configuration data of UVW commutation output ON/OFF. In case of "OFF" setting, the U, V, W pin goes to high-impedance (Hi-Z) output.

UVW Output	R_UVW_E	Default
OFF	0x0	
ON	0x1	●

10-2. R_UVW_HYS Register

R_UVW_HYS registers contain the configuration data of hysteresis filter parameter.

This parameter defines whether the UVW commutation output is updated or not in response to the processing raw angle data change. The UVW commutation output is not updated when the processing raw angle data change is smaller than the hysteresis parameter. The hysteresis parameter LSB is defined to be equal to the LSB for 14-bit angle output data.

WARNING: This hysteresis parameter works independently of R_ABZ_HYS setting.

The relationship between R_UVW_HYS [3:0] and the hysteresis setting value are as follows.

UVW Hysteresis	R_UVW_HYS[3:0]	Default
OFF	0x0	
0LSB	0x1	
1LSB	0x2	•
2LSB	0x3	
3LSB	0x4	
4LSB	0x5	
5LSB	0x6	
6LSB	0x7	
7LSB	0x8	
8LSB	0x9	
9LSB	0xA	
10LSB	0xB	
11LSB	0xC	
12LSB	0xD	
OFF	0xE	
OFF	0xF	