



Chipsmall Limited consists of a professional team with an average of over 10 year of expertise in the distribution of electronic components. Based in Hongkong, we have already established firm and mutual-benefit business relationships with customers from,Europe,America and south Asia,supplying obsolete and hard-to-find components to meet their specific needs.

With the principle of “Quality Parts,Customers Priority,Honest Operation,and Considerate Service”,our business mainly focus on the distribution of electronic components. Line cards we deal with include Microchip,ALPS,ROHM,Xilinx,Pulse,ON,Everlight and Freescale. Main products comprise IC,Modules,Potentiometer,IC Socket,Relay,Connector.Our parts cover such applications as commercial,industrial, and automotives areas.

We are looking forward to setting up business relationship with you and hope to provide you with the best service and solution. Let us make a better world for our industry!



Contact us

Tel: +86-755-8981 8866 Fax: +86-755-8427 6832

Email & Skype: info@chipsmall.com Web: www.chipsmall.com

Address: A1208, Overseas Decoration Building, #122 Zhenhua RD., Futian, Shenzhen, China





AK8775

Hall IC for Pulse Encoder

Overview

AK8775 is a Hall effect latch which detects both “vertical” and “horizontal”(perpendicular and parallel to the marking side of the package) magnetic field at the same time. The result of Hall effect latch operation in vertical and horizontal magnetic field is read out to OUTA pin and OUTB pin. AK8775 is for use in portable devices which uses rotational detection system or incremental pulse encoder such as jog dial utilized for input devices.

Features

- o 1.6 to 5.5V operation
- o Bop, Brp (Vertical, Horizontal) $\pm 1.5\text{mT}$ (Typ.), Highly sensitive
- o Low power operation : Average $90\mu\text{A}$ (Typ.) @ $V_{\text{DD}}=3\text{V}$
- o Two outputs : OUTA (detects vertical magnetic field), OUTB (detects horizontal magnetic field)
- o Small package: SOP-4pin, Halogen free

Block Diagram

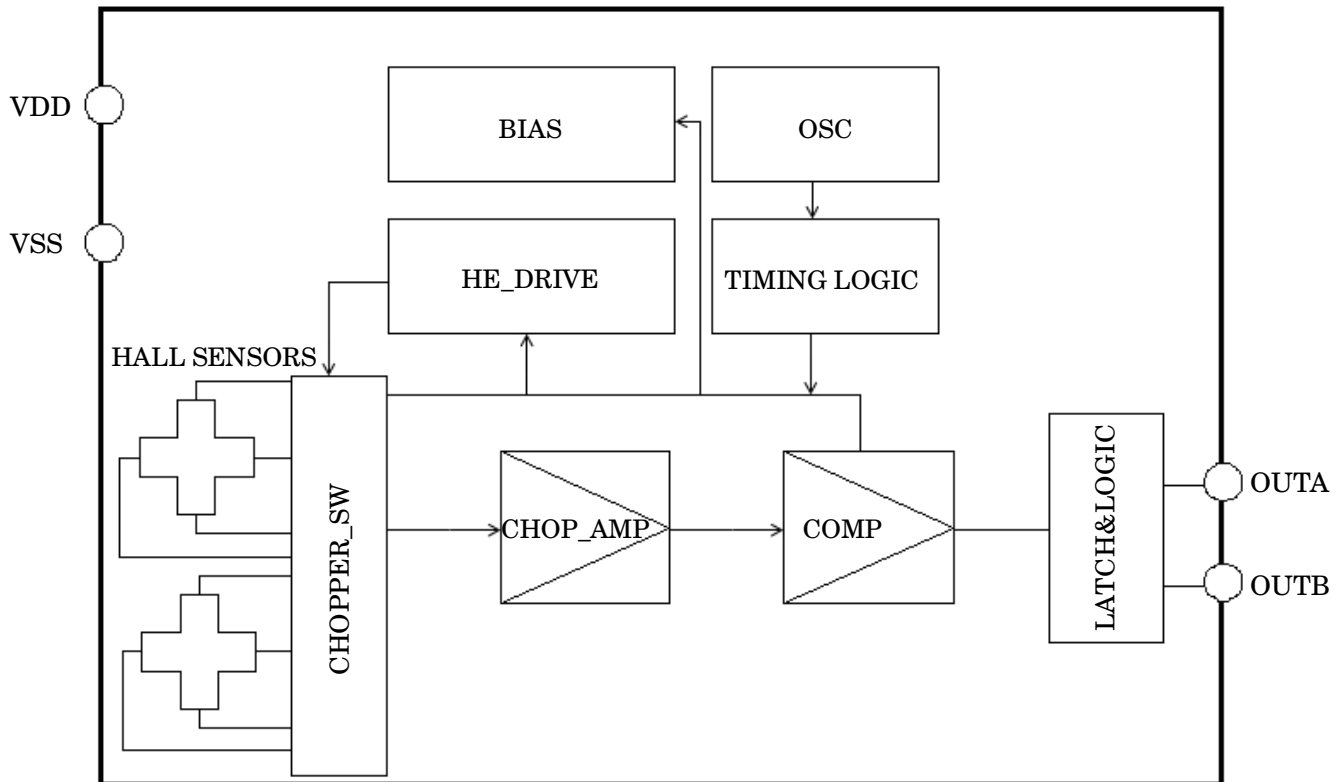

Figure 1. Block diagram

Circuit Configuration

Table 1. Circuit configuration

Block	Function
HALL SENSORS	Two Hall elements fabricated by CMOS process.
CHOPPER_SW	Perform chopping in order to cancel the offset of Hall sensor.
CHOP_AMP	Amplifies two Hall sensor output voltage with summation and subtraction circuit.
COMP	Hysteresis comparator.
BIAS	Generates bias current to other circuits.
HE_DRIVE	Generates bias current for Hall sensors.
OSC	Generates operating clock.
TIMING LOGIC	Generates timing signal required for Chopper SW, AMP and COMP.
LATCH & LOGIC	Logical circuits and CMOS output buffer.

Pin/Function

Table 2. Description of pin name and function

Pin No.	Pin name	I/O	Function	Note
1	VDD	–	Power supply pin	
2	OUTA	O	Output A pin. Relating to the vertical magnetic field	CMOS output
3	OUTB	O	Output B pin. Relating to the horizontal magnetic field	CMOS output
4	VSS	–	Ground pin	

Absolute Maximum Ratings

Table 3. Absolute maximum ratings

Parameter	Symbol	Min.	Max.	Unit	Note
Power supply voltage	V _{DD}	–0.3	+6.5	V	
Output current	I _{OUT}	–0.5	+0.5	mA	OUTA,OUTB pin
Storage temperature	T _{STG}	–40	+125	°C	

Note) Stress beyond these listed values may cause permanent damage to the device.

Recommended Operating Conditions

Table 4. Recommended operating conditions

Parameter	Symbol	Min.	Typ.	Max.	Unit
Power supply voltage	V _{DD}	1.6	3.0	5.5	V
Operating temperature	T _a	–30		+85	°C

Electrical Characteristics

Table 5. Electrical characteristics (T_a=25°C, V_{DD} = 3.0V)

Parameter	Symbol	Min.	Typ.	Max.	Unit	Note
Current consumption	I _{DD}		90	210	μA	Average
High level output Voltage	V _{OH}	V _{DD} -0.4			V	OUTA,OUTB pin, I _{OUT} = –0.5mA
Low level output Voltage	V _{OL}			0.4	V	OUTA,OUTB pin, I _{OUT} = +0.5mA
Pulse drive period	T _{PD1}	0.5	1.0	2.0	ms	
Pulse drive duration time	T _{PD2}	12.2	24.4	48.8	μs	

Note) Internal data is determined just before the internal circuit turns off. And after 6.1μs (Typ.), the output changes.

Magnetic Characteristics

The output OUTA and OUTB is determined by the applied magnetic field and threshold level BopV, BrpV, BopH and BrpH as follows.

Table 6. Magnetic characteristics(Ta = 25°C, V_{DD} = 3.0V)

Parameter	Symbol	Min.	Typ.	Max.	Unit	Note
Vertical magnetic field operating point	BopV		1.5	4.0	mT	(*1)
Vertical magnetic field releasing point	BrpV	-4.0	-1.5		mT	(*1)
Horizontal magnetic field operating point	BopH		1.5	4.0	mT	(*2)
Horizontal magnetic field releasing point	BrpH	-4.0	-1.5		mT	(*2)
Hysteresis	BhV, BhH		3.0		mT	(*1), (*2)

(*1) Horizontal magnetic flux density is zero.

(*2) Vertical magnetic flux density is zero.

Operational Characteristics

AK8775 detects the “vertical” (perpendicular to the marking side of the package) magnetic field, and the resulting output signal OUTA changes state. When the magnetic field is more positive than B_{opV} , the signal OUTA changes to ‘Low’ state. And it is kept while the magnetic field remains more positive than B_{rpV} . When the magnetic field drops below B_{rpV} , the signal OUTA changes to ‘High’ state. Those threshold magnetic flux density levels are defined in Table 6.

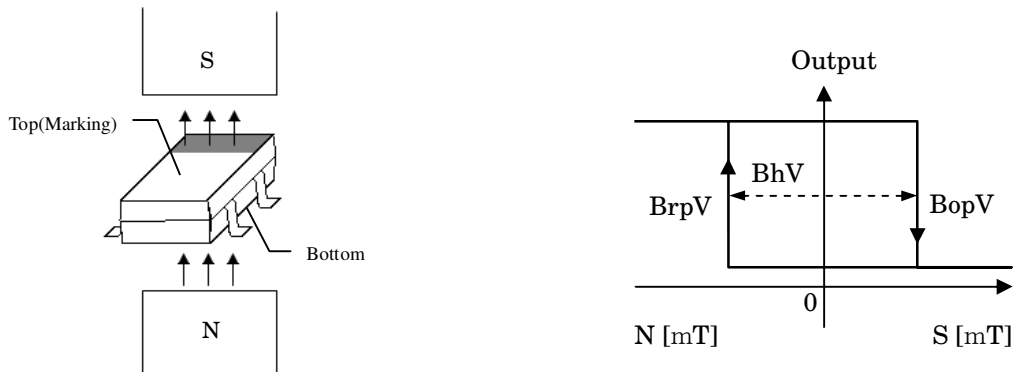

Figure 2. Switching behavior of output signal OUTA when vertical magnetic field is applied

AK8775 detects “horizontal” (parallel to the marking side of the package) magnetic field, and the resulting output signal OUTB changes state. When the magnetic field is more positive than B_{opH} , the signal OUTB changes to ‘Low’ state. And it is kept while the magnetic field remains more positive than B_{rpH} . When the magnetic field drops below B_{rpH} , the signal OUTB changes to ‘High’ state. Those threshold magnetic flux density levels are defined in Table 6.

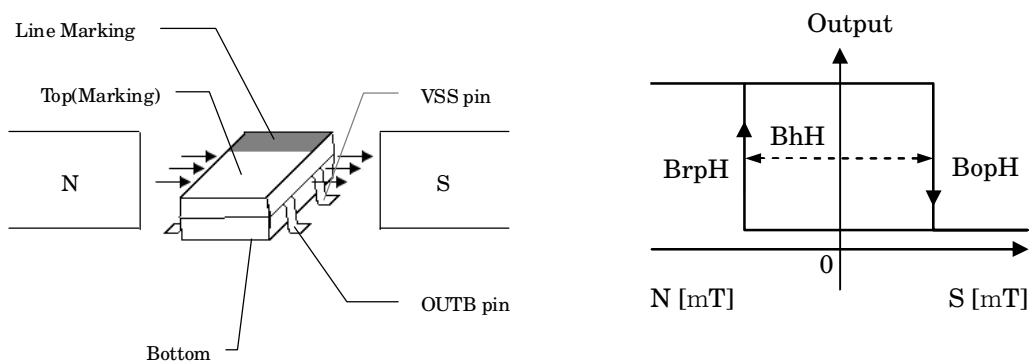

Figure 3. Switching behavior of output signal OUTB when horizontal magnetic field is applied

Functional Timing

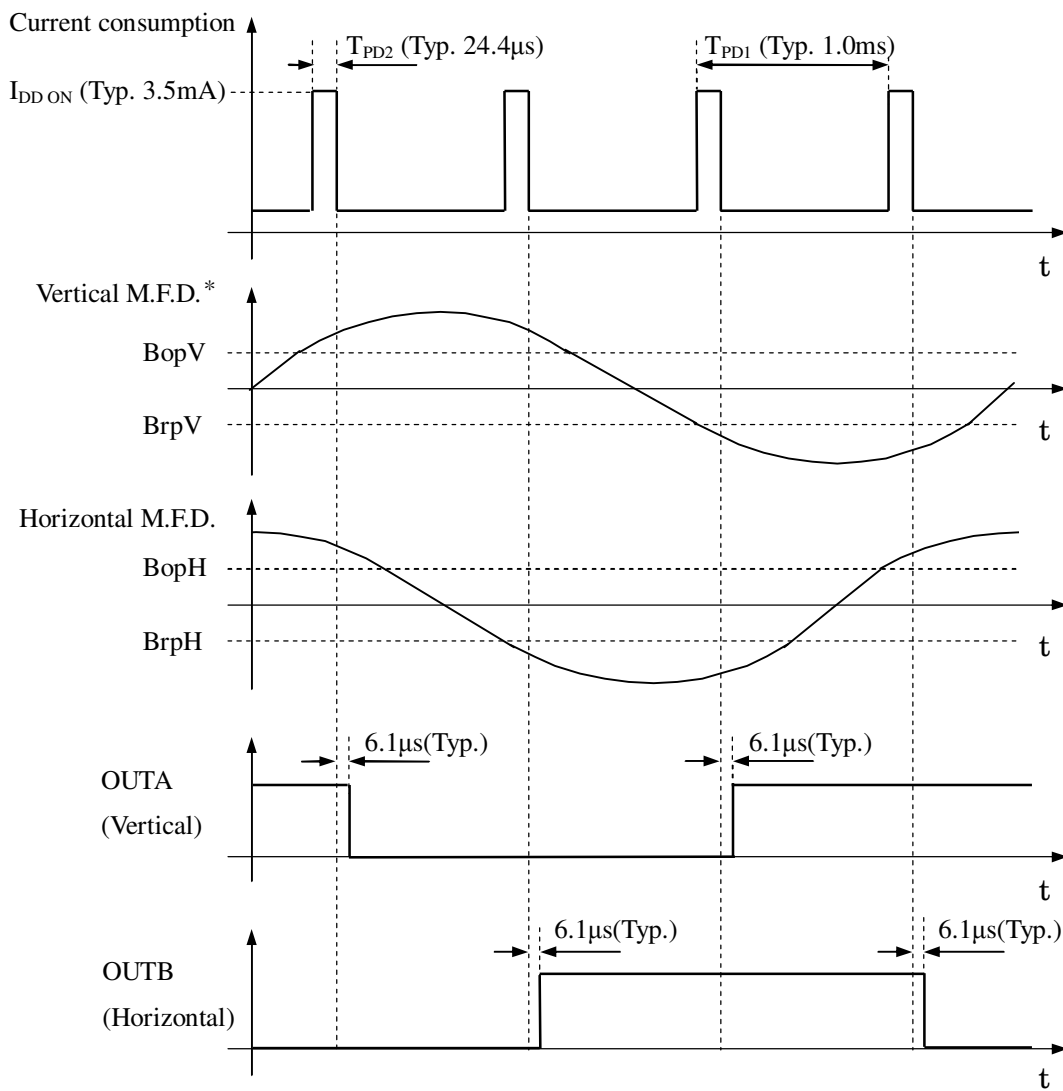

Figure 4. The timing chart of current consumption and transition timing of output signal

*M.F.D. is Magnetic Flux Density.

Note) $V_{DD}=3.0V$.

Typical Characteristic Data (for reference)

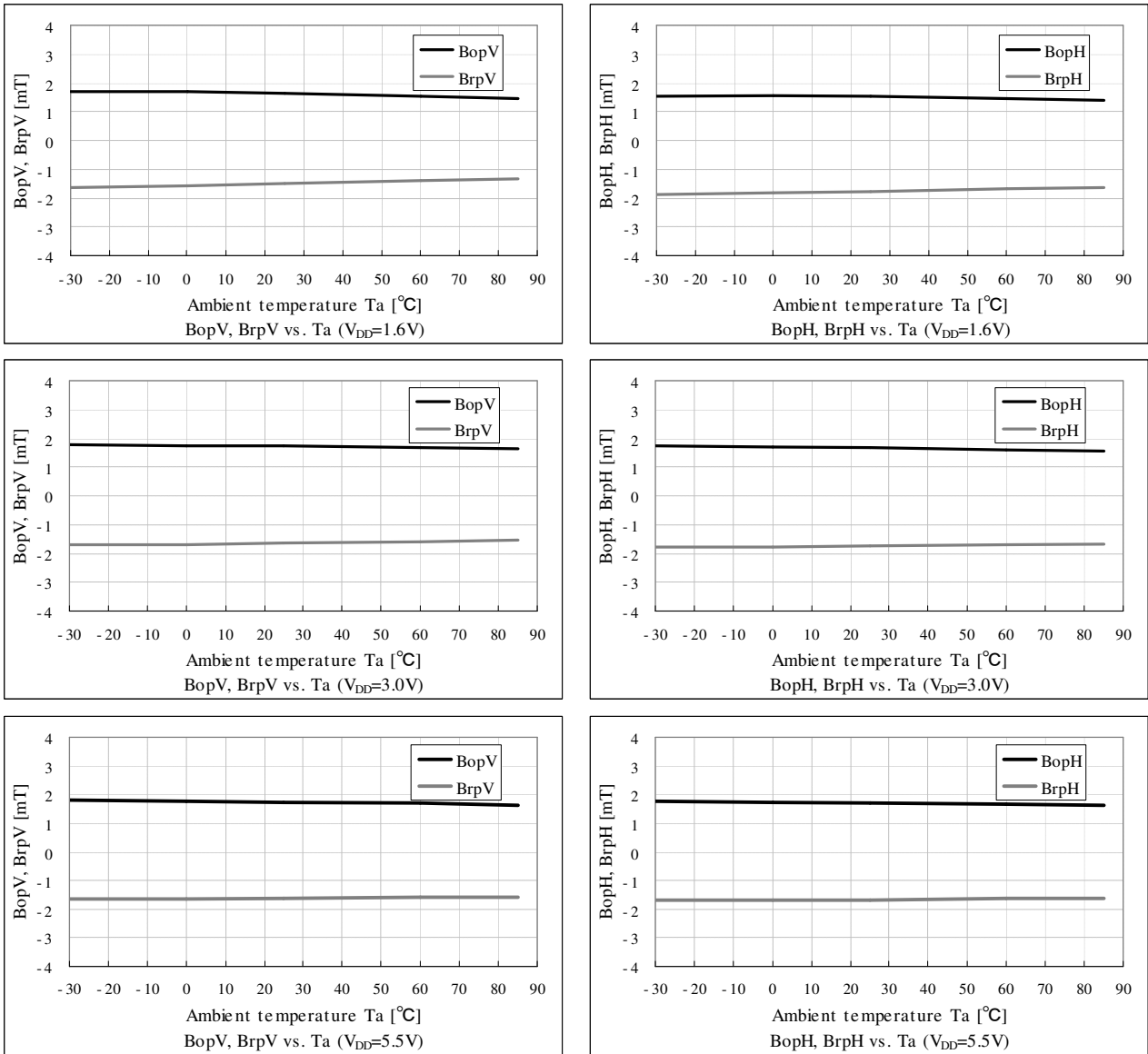

Figure 5. Temperature dependence of sensitivity

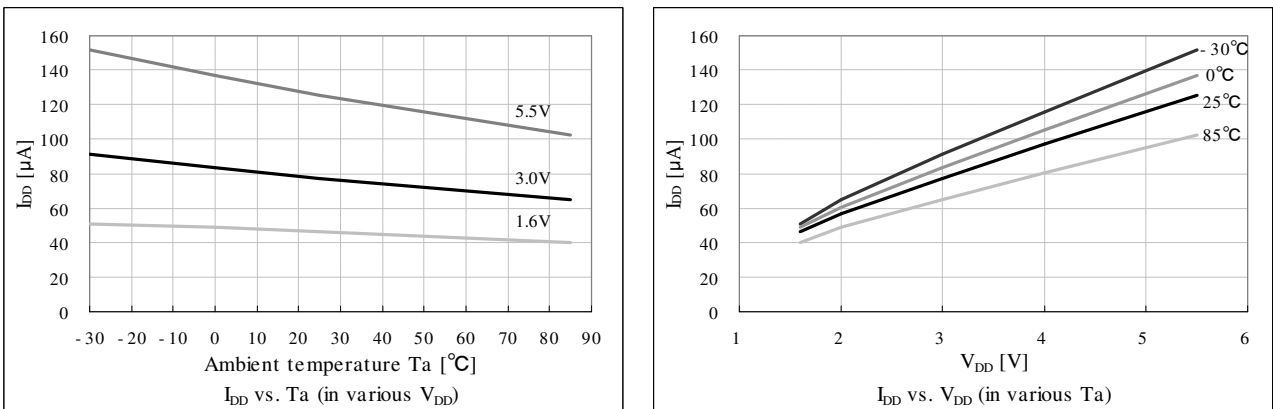

Figure 6. Temperature dependence of current consumption

Package

Unit in mm

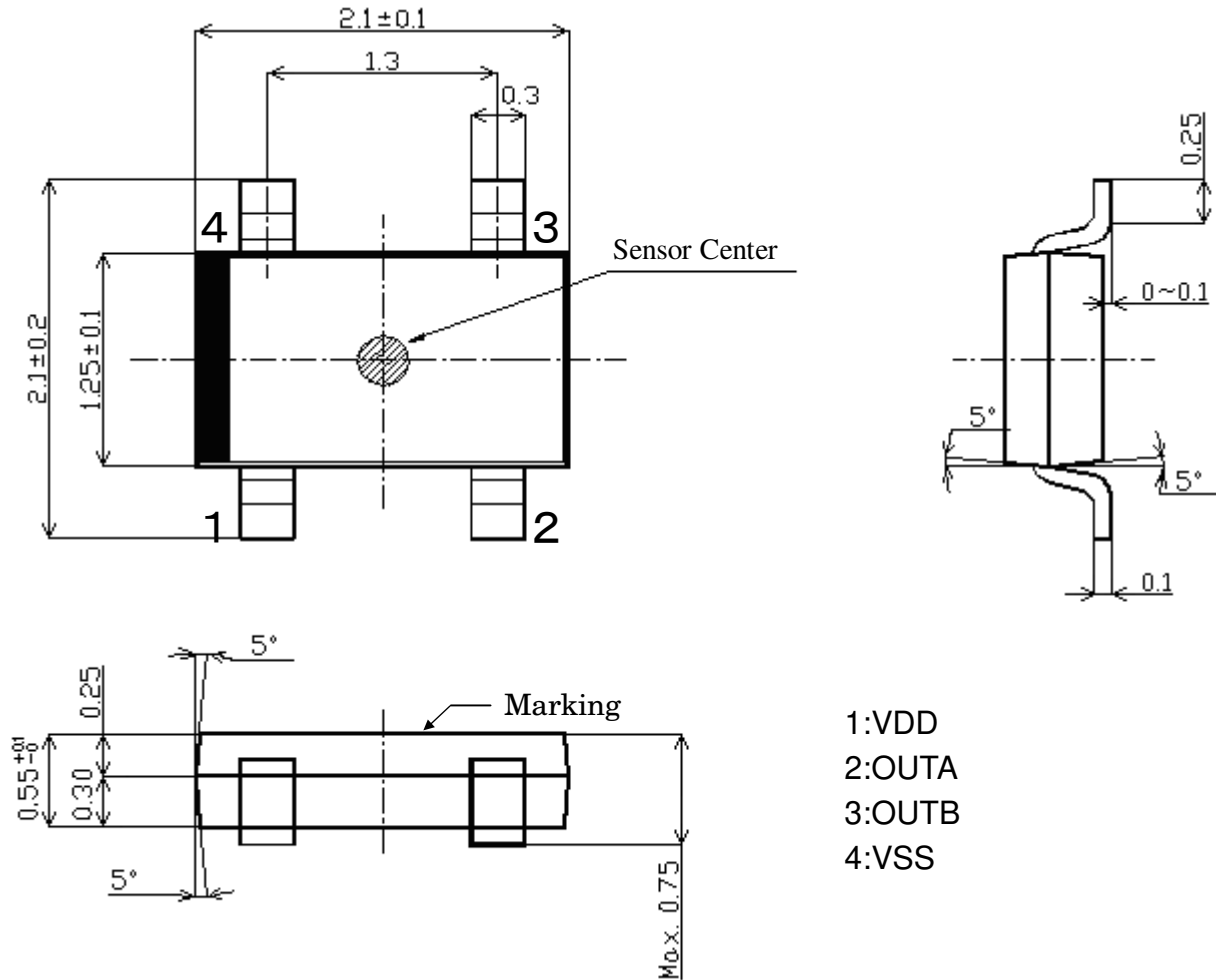

Figure 7. Package dimensions

Note 1) The center of the sensor is located within the $\phi 0.3\text{mm}$ circle.

Note 2) The tolerances of dimensions otherwise noted are $\pm 0.1\text{mm}$.

Note 3) Coplanarity: The differences between standoff of terminals are max. 0.1mm .

Note 4) The sensor part is located $0.4\text{mm} \pm 0.1\text{mm}$ far from marking surface.

Material of terminals: Cu alloy

Material of plating for terminals: Sn 100%

Thickness of plating for terminals: $10\mu\text{m}$ (Typ.)

Marking

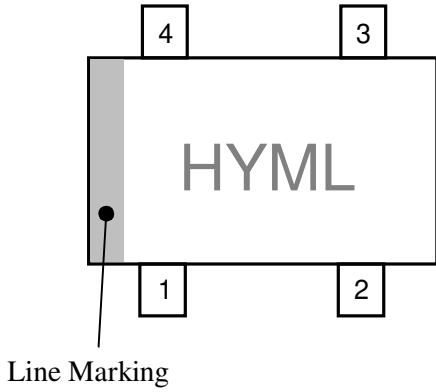

Figure 8. Marking

Marking is performed by laser

Product name : H (AK8775)

Date code : YML

Y : Last one digit of manufactured year (0~ 9)

M : Manufactured month

Jan.	C	Jul.	J
Feb.	D	Aug.	K
Mar.	E	Sept.	L
Apr.	F	Oct.	M
May.	G	Nov.	N
Jun.	H	Dec.	P

L : Lot(1~ 9,A~ Z)

Recommended External Circuit

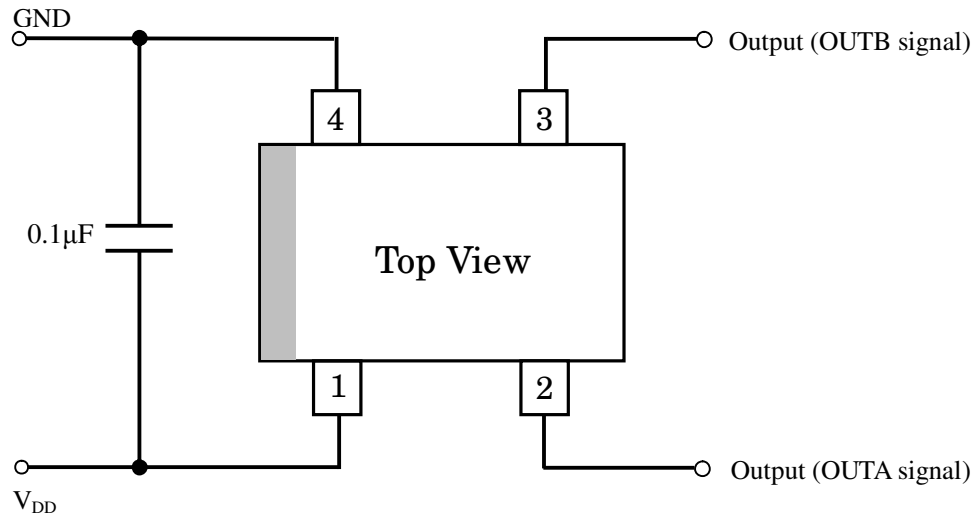

Figure 9. Recommended external circuit

IMPORTANT NOTICE

- | These products and their specifications are subject to change without notice. When you consider any use or application of these products, please make inquiries the sales office of Asahi Kasei Microdevices Corporation (AKM) or authorized distributors as to current status of the products.
- | Descriptions of external circuits, application circuits, software and other related information contained in this document are provided only to illustrate the operation and application examples of the semiconductor products. You are fully responsible for the incorporation of these external circuits, application circuits, software and other related information in the design of your equipments. AKM assumes no responsibility for any losses incurred by you or third parties arising from the use of these information herein. AKM assumes no liability for infringement of any patent, intellectual property, or other rights in the application or use of such information contained herein.
- | Any export of these products, or devices or systems containing them, may require an export license or other official approval under the law and regulations of the country of export pertaining to customs and tariffs, currency exchange, or strategic materials.
- | AKM products are neither intended nor authorized for use as critical components^{Note1)} in any safety, life support, or other hazard related device or system^{Note2)}, and AKM assumes no responsibility for such use, except for the use approved with the express written consent by Representative Director of AKM. As used here:
 - Note1) A critical component is one whose failure to function or perform may reasonably be expected to result, whether directly or indirectly, in the loss of the safety or effectiveness of the device or system containing it, and which must therefore meet very high standards of performance and reliability.
 - Note2) A hazard related device or system is one designed or intended for life support or maintenance of safety or for applications in medicine, aerospace, nuclear energy, or other fields, in which its failure to function or perform may reasonably be expected to result in loss of life or in significant injury or damage to person or property.
- | It is the responsibility of the buyer or distributor of AKM products, who distributes, disposes of, or otherwise places the product with a third party, to notify such third party in advance of the above content and conditions, and the buyer or distributor agrees to assume any and all responsibility and liability for and hold AKM harmless from any and all claims arising from the use of said product in the absence of such notification.