



Chipsmall Limited consists of a professional team with an average of over 10 year of expertise in the distribution of electronic components. Based in Hongkong, we have already established firm and mutual-benefit business relationships with customers from,Europe,America and south Asia,supplying obsolete and hard-to-find components to meet their specific needs.

With the principle of “Quality Parts,Customers Priority,Honest Operation,and Considerate Service”,our business mainly focus on the distribution of electronic components. Line cards we deal with include Microchip,ALPS,ROHM,Xilinx,Pulse,ON,Everlight and Freescale. Main products comprise IC,Modules,Potentiometer,IC Socket,Relay,Connector.Our parts cover such applications as commercial,industrial, and automotives areas.

We are looking forward to setting up business relationship with you and hope to provide you with the best service and solution. Let us make a better world for our industry!



Contact us

Tel: +86-755-8981 8866 Fax: +86-755-8427 6832

Email & Skype: info@chipsmall.com Web: www.chipsmall.com

Address: A1208, Overseas Decoration Building, #122 Zhenhua RD., Futian, Shenzhen, China



General Description

These four key elements, AC-to-DC Power Stage, LED Driver, LED Emitter Module and Wireless Connectivity block (enabled by embedded MCU and RF), form a typical system configuration for Smart Connected Lighting (SCL) bulbs. AL1794, a four-channel Constant Current Regulator (CCR) LED driver with analog and PWM dimming control, is targeted for Tunable White/Color SCL applications. Powered by Constant Voltage (CV) power source(s) provided by an AC-DC Power Conversion Block, AL1794 generates Constant Currents (CC) driving attached LED emitter strings. The channel currents are further modulated by analog or digital PWM signals generated by the associated external MCU.

Key Merits

- Cost-Effectiveness
- Dimming Performance
- Ease of System Implementation

Key Features

- Input voltage range: 6.5V_{DC} to 30V_{DC}
- 4-Channel LED drivers: Independent Analog or PWM dimming control for each channel
- Reference Current: Adjustable R_{SET}
- Low Standby Power with Enable pin
- E-flicker free High PWM Frequency dimming: 0.1%@1KHz, 0.4%@4KHz, 1.0%@10KHz
- UVLO, OTP, Open, and Short protection
- Operating Temperature Range: -40°C to +125°C
- Low system BOM cost
- U-DFN4030-14 “Green” Moulding Compound package

Applications

- 1-Channel Dimmable SCL Bulbs
- 2-Channel Tunable White SCL Bulbs
- 3-Channel Tunable White SCL Bulbs
- 4-Channel Tunable White+Color SCL Bulbs
- Smart Connected LED Tubes, Panel Lights, Troffers, and Ceiling Lights

AL1794 EV1 Specifications

Parameter	Value
VLED1 Input Voltage	6.5V _{DC} to 24V _{DC} (Note 1), connect to Anode of LEDs strings
VLED2 Input Voltage	Connect to Anode of LEDs strings if a separate voltage for LEDs stings is required
Input Voltages for LED1, 2, 3, and 4	0.25V (Minimum)
3.3V LDO	150mA (Maximum)
LED_Bar Connectors (Top, Male)	6pins, Power and LED Inputs
MCU1 Connectors (Bottom, Male)	10pins, PWM Signals Input
IC Pin Test points	16 test points (J3 and J4)
XYZ Dimension	1.9" x 2.0" x 0.6"

Note 1: Vin(max) for AL1794 is capable of up to 30V, but Vin(max) for AP2204K (3.3V @ 150mA for MCU Power) limits the Vin(max) of AL1794EV1 Board to 24V only. If higher than 24V is required for testing, users can drive Vin up to 30V as long as 3.3V power output from the AP2204K is NOT used.

AL1794 IC Pin Assignment

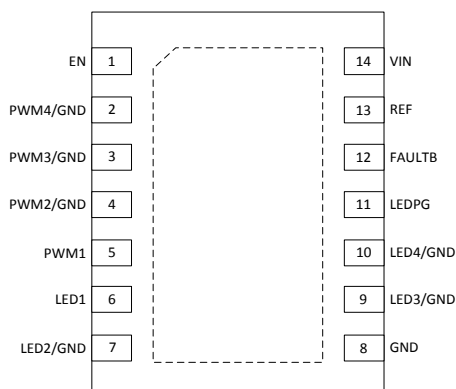

Pin Name	Part Number	Descriptions
	U-DFN4030-14	
EN	1	Active-high to Enable, Internally Pulled Down
PWM4/GND	2	PWM Signal Input for channel 4, Internally Pulled Down for AL1794. GND for AL1791, AL1792, and AL1793.
PWM3/GND	3	PWM Signal Input for channel 3, Internally Pulled Down for AL1793 and AL1794. GND for AL1791 and AL1792.
PWM2/GND	4	PWM Signal Input for channel 2, Internally Pulled Down for AL1792, AL1793, and AL1794. GND for AL1791.
PWM1	5	PWM Signal Input for channel 1, Internally Pulled Down (Tied to GND when this channel is NOT used).
LED1	6	Channel 1 LED Cathode
LED2/GND	7	Channel 2 LED Cathode for AL1792, AL1793, and AL1794. GND for AL1791.
GND	8	Ground
LED3/GND	9	Channel 3 LED Cathode for AL1793 and AL1794. GND for AL1791 and AL1792.
LED4/GND	10	Channel 4 LED Cathode for AL1794. GND for AL1791, AL1792, and AL1793.
LEDPG	11	LED Power Good Indication. Asserted Low to report insufficient headroom. Needs an external pull-up resistor.
FAULTB	12	Fault Report. Asserted Low to report faulty conditions. Needs an external pull-up resistor.
REF	13	Reference Current Setting through External Resistor (R_{SET})
VIN	14	Voltage Input
Exposed PAD	Exposed PAD	Exposed pad. Internally connected to GND. It should be externally connected to GND and thermal mass for enhanced thermal impedance. It should not be used as electrical conduction path.

Evaluation Board

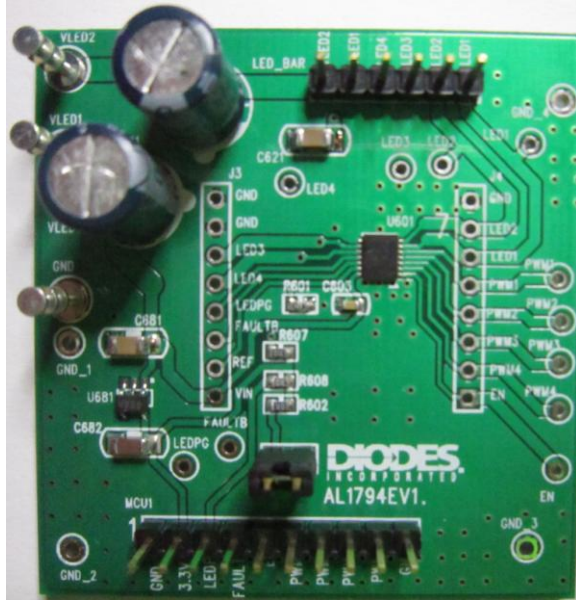

Figure 1: Top View

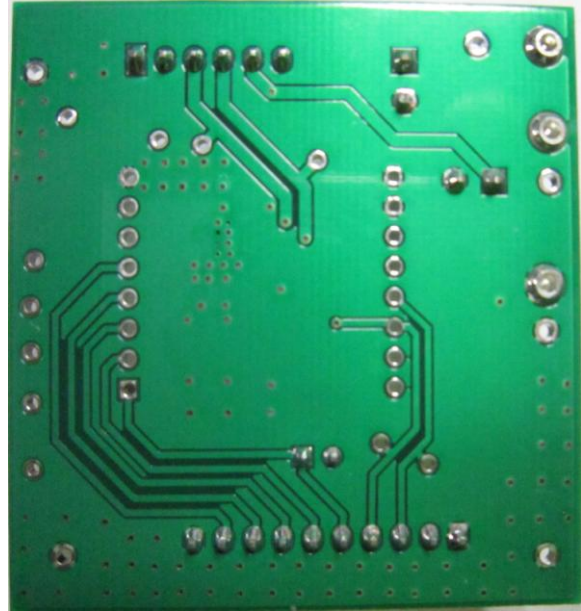

Figure 2: Bottom View

Connector Pin Definition:

1. Power and Ground Terminals (3 pins)

- 1) **VLED1** - AL1794 VIN, 3.3V LDO Input, and Emitter String Power Input to Anode of Emitter Strings. – Upper left corner (Top View)
- 2) **VLED2** - Emitter String Power Input to Anode of Emitter Strings.
- 3) **GND** - Ground

2. LED_BAR Connectors (6 pins) - (Left to Right Pin Sequence)

- 1) **LED1 (IN)** - Connected to Cathode of Emitter String #1 - Right most pin (Top View)
- 2) **LED2 (IN)** - Connected to Cathode of Emitter String #2
- 3) **LED3 (IN)** - Connected to Cathode of Emitter String #3
- 4) **LED4 (IN)** - Connected to Cathode of Emitter String #4
- 5) **VLED1 (OUT)** - Emitter String Power Input to Anode of Emitter Strings.
- 6) **VLED2 (OUT)** - Emitter String Power Input to Anode of Emitter Strings.

3. MCU1 Connectors (10 pins) - (Left to Right Pin Sequence)

- 1) **GND** - Ground - Leftmost pin (Top View)
- 2) **3.3V (OUT)** - 3.3V (output for MCU Power); Generated by AP2204K-3.3 (**WIDE INPUT VOLTAGE RANGE, 150mA ULDO REGULATOR,** <http://diodes.com/datasheets/AP2204.pdf>) with Vin(max) at 24V.
- 3) **LEDPG (OUT)** - LED Power Good signal
- 4) **FAULTB (OUT)** - FaultB, active low, indication of fault occurrence
- 5) **EN (IN)** - Enable AL1794 to turn ON
- 6) **PWM4 (IN)** - PWM signal for Channel #4
- 7) **PWM3 (IN)** - PWM signal for Channel #3
- 8) **PWM2 (IN)** - PWM signal for Channel #2
- 9) **PWM1 (IN)** - PWM signal for Channel #1
- 10) **GND**

4. Test Points

- 1) **VLED1** Connected to VLED1
- 2) **VLED2** Connected to VLED2
- 3) **GND_1, GND_2, GND_3, GND_4** Connected to GND
- 4) **EN** Connected to AL179x Pin#1
- 5) **PWM4** Connected to AL179x Pin#2
- 6) **PWM3** Connected to AL179x Pin#3
- 7) **PWM2** Connected to AL179x Pin#4
- 8) **PWM1** Connected to AL179x Pin#5
- 9) **LED1** Connected to AL179x Pin#6
- 10) **LED2** Connected to AL179x Pin#7
- 11) **LED3** Connected to AL179x Pin#9
- 12) **LED4** Connected to AL179x Pin#10
- 13) **LEDPG** Connected to AL179x Pin#11
- 14) **FAULTB** Connected to AL179x Pin#12

Board Setup Procedure

The channel current ratio for Channel 1, 2, 3 and 4 are fixed at 1:1:0.75:0.25. The default Channel Current of LED1, LED2, LED3 and LED4, are preset at 250mA, 250mA, 187.5mA and 62.5mA, respectively with Rset (R601) of 12KΩ. Users can change the current setting by replacing Rset to obtain desired current value as follows:

$$I_{LED1} = 2000 * \frac{V_{REF}}{R_{SET}}$$

$$I_{LED2} = 2000 * \frac{V_{REF}}{R_{SET}}$$

$$I_{LED3} = 1500 * \frac{V_{REF}}{R_{SET}}$$

$$I_{LED4} = 500 * \frac{V_{REF}}{R_{SET}}$$

where $V_{REF} = 1.5V$ nominally for all devices

1. Ensure that the DC source is switched OFF or disconnected.
2. Connect the DC line wires of power supply to VIN and GND terminals on the board.
3. Connect the anode wire of external LED string to VLED1 of the board.
4. Connect the cathode wire of the external LED emitter strings to relevant LED channels inputs (LED1, LED2, LED3, LED4) of the board.
5. Make sure the length of both anode/cathode wires connected between AL1794EV1 and LEDs strings is minimized (less than 1 inch) to reduce wire inductance and improve ringing performance.
6. Ensure that the area around the board is clear and safe, and preferably that the board and LEDs are enclosed in a transparent safety cover.
7. Turn on the main DC Power switch.
8. Send proper PWM Signal pattern and then turn ON the EN pin (High) to enable the AL1794 IC.
9. LED strings should light up according to the Dimming pattern driven by PWM signals.

CAUTION:

1. Make sure the maximum DC input voltage is not higher than 30V_{DC} (if 3.3V Power Output is NOT used), or 24V_{DC} (if 3.3V Power Output is used).

2. If different current is required, please modify the Rset (R601) to proper value before start the Turn-On procedure.
3. The maximum recommended channel current is at 500mA (for channel 1 and 2) with Rset (R601) at 6KΩ.
4. Channel PWM Dimming patterns are recommended to be spread out to avoid sharp turn-on and turn-off rush currents.
5. Though there are various protection mechanism built in AL1794, it is good practice to check maximum dimming pattern to avoid Thermal Shutdown (when Case Ambient Temperature exceeds 160°C). Thermal resistivity θ_{ja} (Junction-to-Ambient) of AL1794 is 55 °C/Watt. AL1794 will have to absorb any additional voltage headroom provided by the VLED power input to the Anodes of Emitter Strings. Therefore, thermal management of AL1794 must follow the following guidelines:
 - PDmax (Maximum Power Dissipation) = (160°C Junction Shutdown Temperature - Ambient Temperature, e.g. 85°C) / 55°C/W = 1.364Watts
 - PAmx (Power to be Absorbed by AL179x) = $\Sigma(\text{VLEDx} * \text{Current through the emitter string} * \text{Associated PWM Dimming Duty Cycle})$
 - Thermal Management Guideline $\text{PA}_{\text{max}} < \text{PD}_{\text{max}}$

PWM Dimming Linearity Tests

Using PWM Dimming signals to create desired dimming effects had the advantages of reducing current to desired ratio without changing either CCT (Correlated Color Temperature) of White emitters or causing Color shifts of Color emitters. To avoid **eFlicker** ("Dark Stripes on Images" when taking photos or videos with Smartphones under PWM dimmed Lighting situation), users can use **higher PWM frequency** (e.g. **4KHz and above**). The dimming linearity performance at **Deep Dimming (less than 1% light output)** is very important as human eyes are very sensitive to low light situations.

For example,

- **10% of measured light is 30% of perceived light**
- **5% of measured light is 22% of perceived light**
- **1% of measured light is 10% of perceived light**
- **0.1% of measured light is 3% of perceived light**

Source: IESNA Lighting Handbook, 9th Edition, (New York; IESNA, 2000), 27-4.

Dimming Performances: (PWM Frequency 4KHz, 1KHz, and 10KHz)

1. 4KHz PWM Dimming Current Linearity Test for Channel 1, 2, 3 and 4 (250mA:250mA:187.5mA:62.5mA)

Full-Range (0 - 100%) 4KHz PWM Dimming Performance

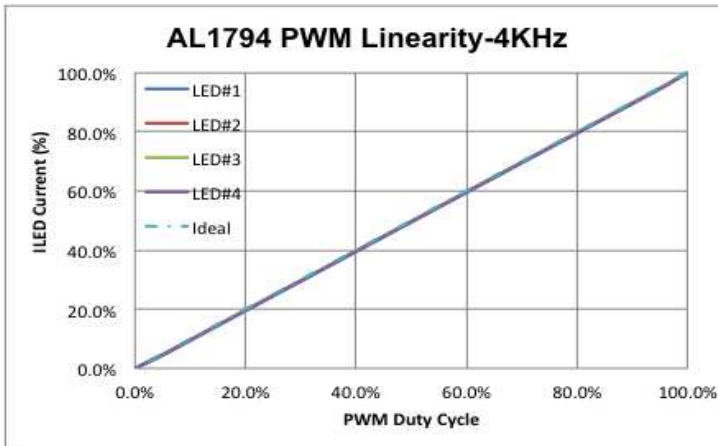

Figure 3: 4KHz PWM Dimming Performance

Deep Dimming (0 - 10%) 4KHz PWM Dimming Performance

Deep dimming performance of PWM signals are critical performance factor as human eyes are more sensitive to brightness change at low light level

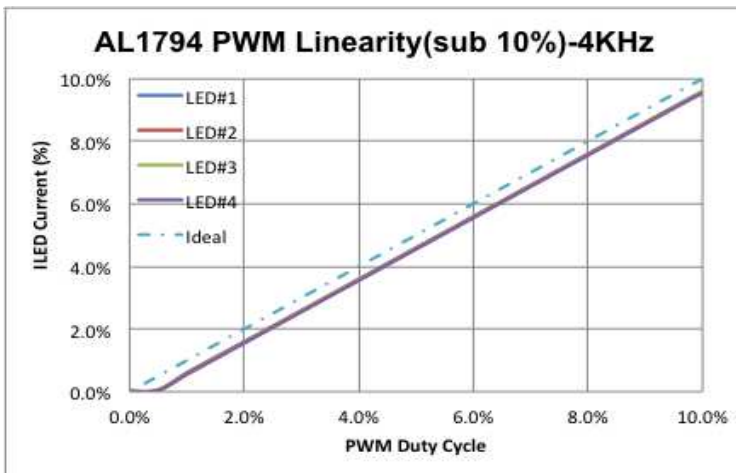

Figure 4: 4KHz PWM Dimming Performance below 10% Dimming

2. 1KHz PWM Dimming Current Linearity Test for Channel 1, 2, 3 and 4 (250mA:250mA:187.5mA:62.5mA)

Full-Range (0 - 100%) 10KHz PWM Dimming Performance

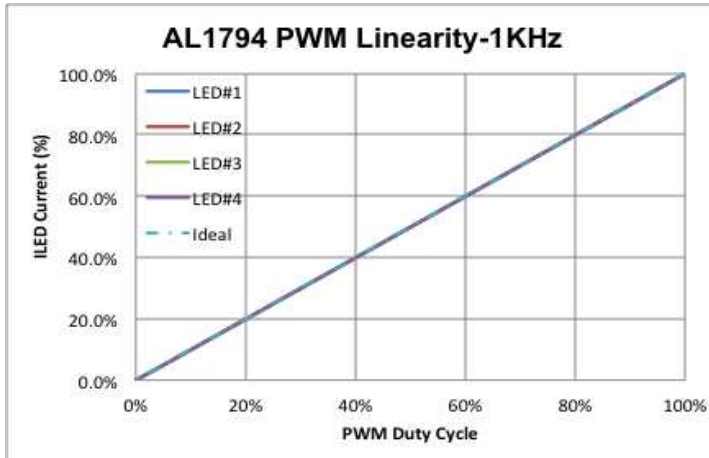

Figure 5: 1KHz PWM Dimming Performance

Deep Dimming (0 - 10%) 1KHz PWM Dimming Performance

Using 1KHz PWM signal (vs. 4KHz) will further improve Deep Dimming Linearity performance.

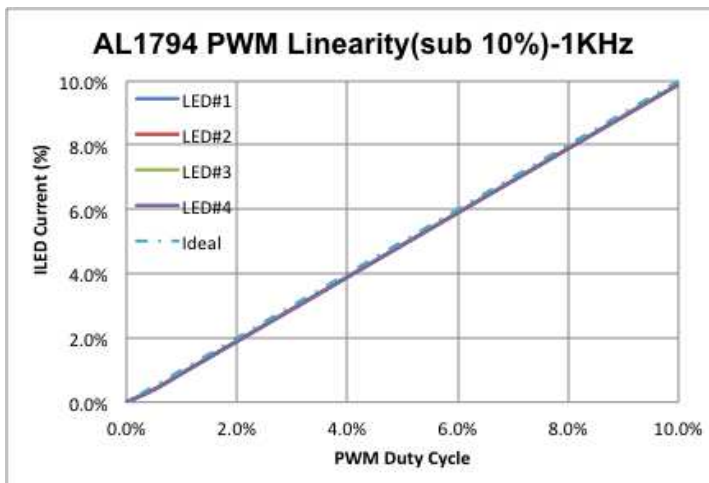

Figure 6: 1KHz PWM Dimming Performance below 10% Dimming

3. 10KHz PWM Dimming Current Linearity Test for Channel 2

Full-Range (0 - 100%) Dimming Performance

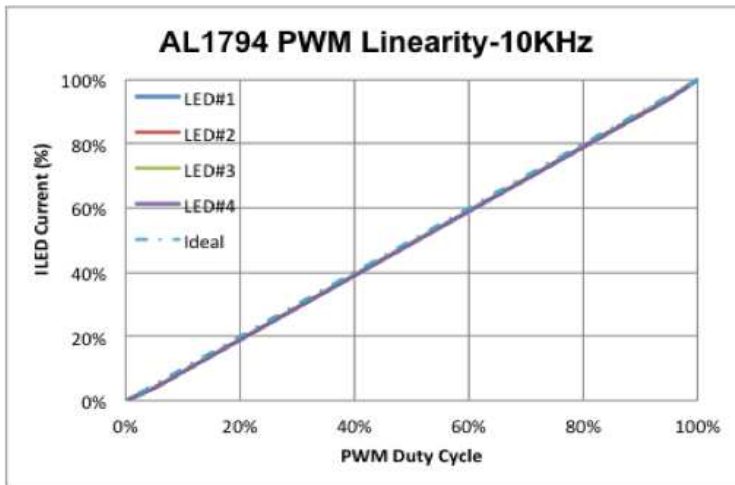

Figure 7: 10KHz PWM Dimming Performance

Deep Dimming (0 - 10%) 10KHz PWM Dimming Performance

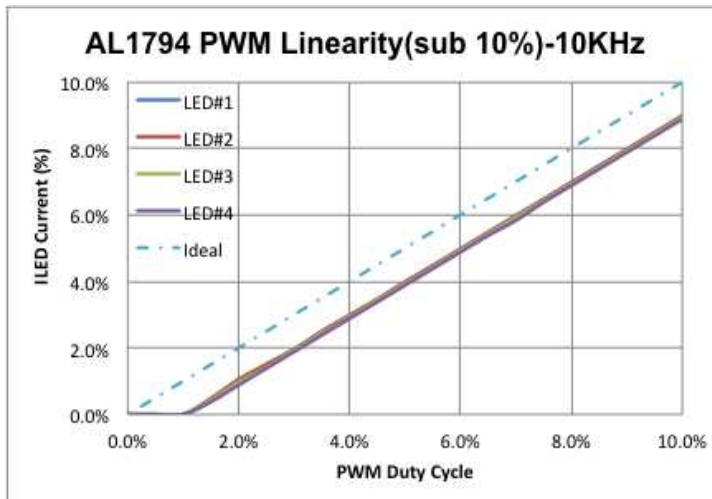

Figure 8: 10KHz PWM Dimming Performance 0%-10% Dimming

Evaluation Board Schematic

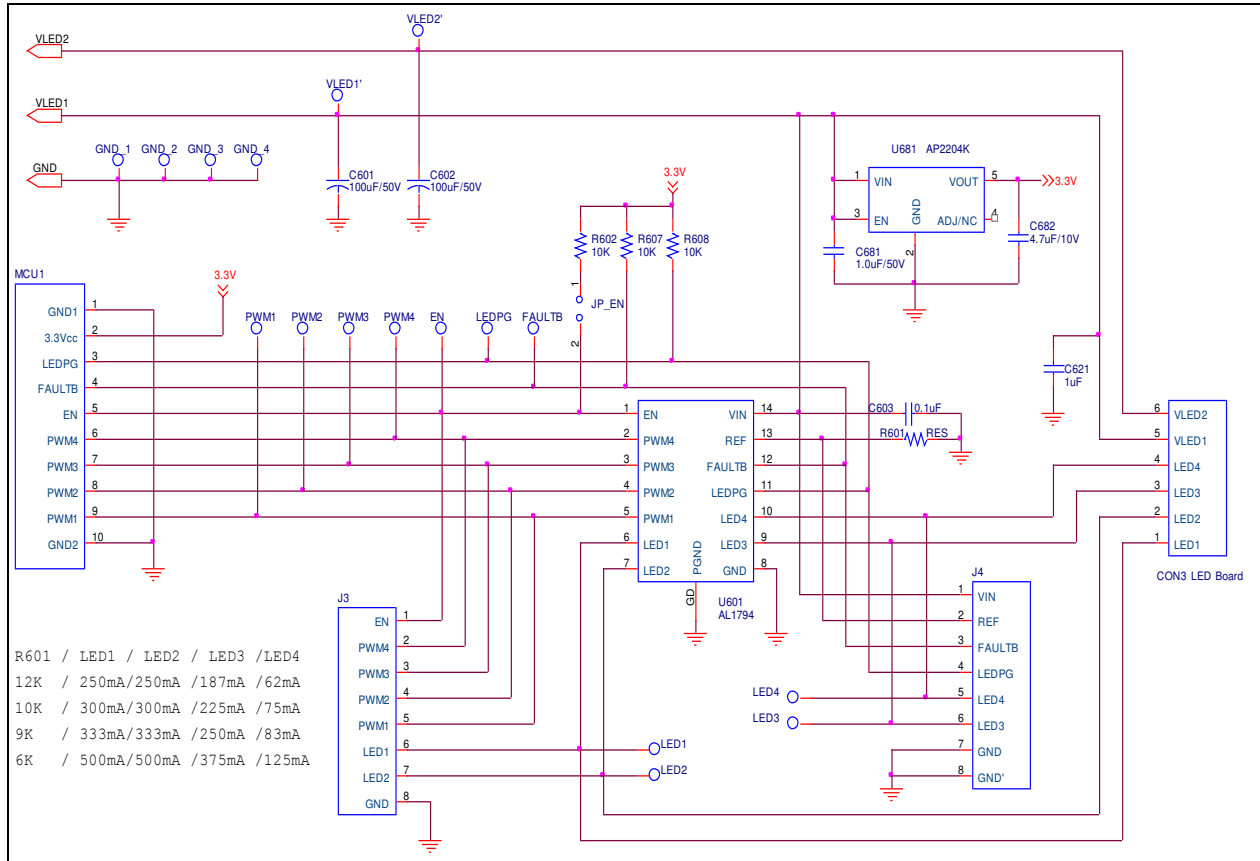

Figure 9: Evaluation Board Schematic

Bill of Material

#	Name	QTY	Part number	Manufacturer	Description
1	U601	1	AL1794AFE-13	Diodes Inc	4-Channel LED Driver
2	U681	1	AP2204K-3.3VTRG1	Diodes Inc	Wide-Input (2.5V-24V) 150mA ULDO
3	C601	1	ECA-1HM101	Panasonic	E-CAP 100uF 50V (8x11.5mm)
4	C602	1	ECA-1HM101	Panasonic	E-CAP 100uF 50V (8x11.5mm)
5	C603	1	CC0603KRX7R9BB104	Yageo	CAP CER 0.1uF 50V X7R 0603
6	C621	1	CC0805KRX7R9BB104	Yageo	CAP CER 1.0uF 50V X7R 0805
7	C681	1	CC0805KRX7R9BB104	Yageo	CAP CER 1.0uF 50V X7R 0805
8	C682	1	CC0805ZRY5V6BB475	Yageo	CAP CER 4.7uF 10V X7R 0805
9	R601 (Rset)	1	RC0603JR-0712KL	Yageo	RES 12KΩ 1/10W 5% 0603 SMD
10	R602	1	RC0603JR-0710KL	Yageo	RES 10KΩ 1/10W 5% 0603 SMD
11	R607	1	RC0603JR-0710KL	Yageo	RES 10KΩ 1/10W 5% 0603 SMD
12	R608	1	RC0603JR-0710KL	Yageo	RES 10KΩ 1/10W 5% 0603 SMD
13	JP_EN	1	800-10-002-10-001000	Mill-Max	Enable 2 pin SIP header w/Jumper
14	LED_BAR	1	800-10-006-10-001000	Mill-Max	LED Emitter Output I/O 6pin SIP header
15	MCU1	1	800-10-010-10-001000	Mill-Max	MCU I/O 10pin SIP header
16	VLED1	1	534-1598-2	Mouser	VLED1 Anode Input, Term 0.094"x1/16"
17	VLED2	1	534-1598-2	Mouser	VLED2 Anode Input, Term 0.094"x1/16"
18	GND	1	534-1598-2	Mouser	Ground Input, Term 0.094"x1/16"

IMPORTANT NOTICE

DIODES INCORPORATED MAKES NO WARRANTY OF ANY KIND, EXPRESS OR IMPLIED, WITH REGARDS TO THIS DOCUMENT, INCLUDING, BUT NOT LIMITED TO, THE IMPLIED WARRANTIES OF MERCHANTABILITY AND FITNESS FOR A PARTICULAR PURPOSE (AND THEIR EQUIVALENTS UNDER THE LAWS OF ANY JURISDICTION).

Diodes Incorporated and its subsidiaries reserve the right to make modifications, enhancements, improvements, corrections or other changes without further notice to this document and any product described herein. Diodes Incorporated does not assume any liability arising out of the application or use of this document or any product described herein; neither does Diodes Incorporated convey any license under its patent or trademark rights, nor the rights of others. Any Customer or user of this document or products described herein in such applications shall assume all risks of such use and will agree to hold Diodes Incorporated and all the companies whose products are represented on Diodes Incorporated website, harmless against all damages.

Diodes Incorporated does not warrant or accept any liability whatsoever in respect of any products purchased through unauthorized sales channel.

Should Customers purchase or use Diodes Incorporated products for any unintended or unauthorized application, Customers shall indemnify and hold Diodes Incorporated and its representatives harmless against all claims, damages, expenses, and attorney fees arising out of, directly or indirectly, any claim of personal injury or death associated with such unintended or unauthorized application.

Products described herein may be covered by one or more United States, international or foreign patents pending. Product names and markings noted herein may also be covered by one or more United States, international or foreign trademarks.

This document is written in English but may be translated into multiple languages for reference. Only the English version of this document is the final and determinative format released by Diodes Incorporated.

LIFE SUPPORT

Diodes Incorporated products are specifically not authorized for use as critical components in life support devices or systems without the express written approval of the Chief Executive Officer of Diodes Incorporated. As used herein:

A. Life support devices or systems are devices or systems which:

1. are intended to implant into the body, or
2. support or sustain life and whose failure to perform when properly used in accordance with instructions for use provided in the labeling can be reasonably expected to result in significant injury to the user.

B. A critical component is any component in a life support device or system whose failure to perform can be reasonably expected to cause the failure of the life support device or to affect its safety or effectiveness.

Customers represent that they have all necessary expertise in the safety and regulatory ramifications of their life support devices or systems, and acknowledge and agree that they are solely responsible for all legal, regulatory and safety-related requirements concerning their products and any use of Diodes Incorporated products in such safety-critical, life support devices or systems, notwithstanding any devices- or systems-related information or support that may be provided by Diodes Incorporated. Further, Customers must fully indemnify Diodes Incorporated and its representatives against any damages arising out of the use of Diodes Incorporated products in such safety-critical, life support devices or systems.

Copyright © 2015, Diodes Incorporated

www.diodes.com