



Chipsmall Limited consists of a professional team with an average of over 10 year of expertise in the distribution of electronic components. Based in Hongkong, we have already established firm and mutual-benefit business relationships with customers from,Europe,America and south Asia,supplying obsolete and hard-to-find components to meet their specific needs.

With the principle of “Quality Parts,Customers Priority,Honest Operation,and Considerate Service”,our business mainly focus on the distribution of electronic components. Line cards we deal with include Microchip,ALPS,ROHM,Xilinx,Pulse,ON,Everlight and Freescale. Main products comprise IC,Modules,Potentiometer,IC Socket,Relay,Connector.Our parts cover such applications as commercial,industrial, and automotives areas.

We are looking forward to setting up business relationship with you and hope to provide you with the best service and solution. Let us make a better world for our industry!



Contact us

Tel: +86-755-8981 8866 Fax: +86-755-8427 6832

Email & Skype: info@chipsmall.com Web: www.chipsmall.com

Address: A1208, Overseas Decoration Building, #122 Zhenhua RD., Futian, Shenzhen, China



AL8806EV6 USER GUIDE

Performance

- 12VDC and 12VAC input
- 1.1A LED current
- Drives 1 to 3 LEDs in series
- 2% current regulation 9V to 30VDC (with 2 LEDs)
- Ambient temperature range -40°C to +105°C

Ordering Information

Order Number
AL8806EV6

Introduction

This evaluation circuit demonstrates the AL8806 High Efficiency 30V 1.5A Buck LED Driver operating in a circuit providing 1.1A LED current in MR16 form intended to drive 1 to 3 high brightness LEDs in series with a total load voltage drop up to 10V. The circuit includes a 470 μ F reservoir capacitor to prevent flicker for 50Hz or 60Hz AC input power. EMC filtering is included to meet international standards including the radiated emission requirements of EN55015 and EN55022 Class B.

The switching frequency is approximately 440kHz when driving 2 Osram Dragon Diamond LEDs.

The construction uses a double-sided FR4 printed circuit board, 17 x 20 x 0.8 mm with 2oz/sq ft copper (70 μ m). Components are mounted on both sides.

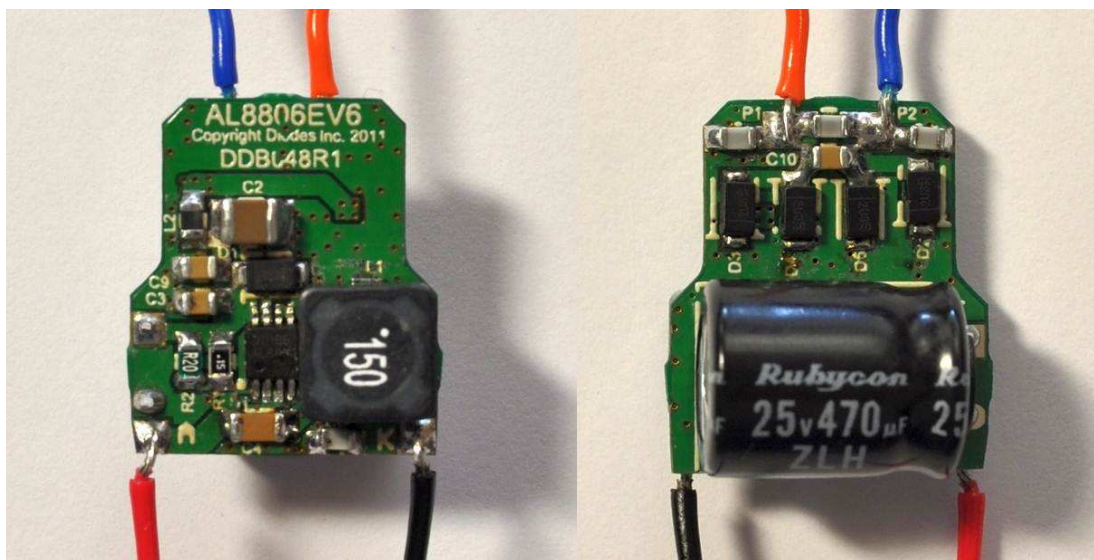

Quick Start Guide

Suitable Test Equipment

Count	Description	Manufacturer	Part Number
1	Adjustable Power Supply, 12V 2A	Thurlby Thandar	CPX400A
2	Digital Multimeter	Fluke	179
1	Digital Storage Oscilloscope	Tektronix	TDS2024B
2	LED, high brightness, "Dragon Diamond", series connected on suitable heat conducting PCB	Osram	

CAUTION: The LEDs are very bright. Ensure they are hidden from direct view, or covered with a dispersing filter. The lid from an aerosol can is convenient for this.

Also the LEDs are very hot. Do not touch!!

Lamp Operation

1. Set the power supply to 12.0V but do not switch on. Set the current limit to 2.0A.
2. Connect up the AL8806EV6 board to the equipment as in **Figure 1** below. Set DMM1 and DMM2 to measure current up to 2A.

Figure 1: Test Schematic using VDC Input

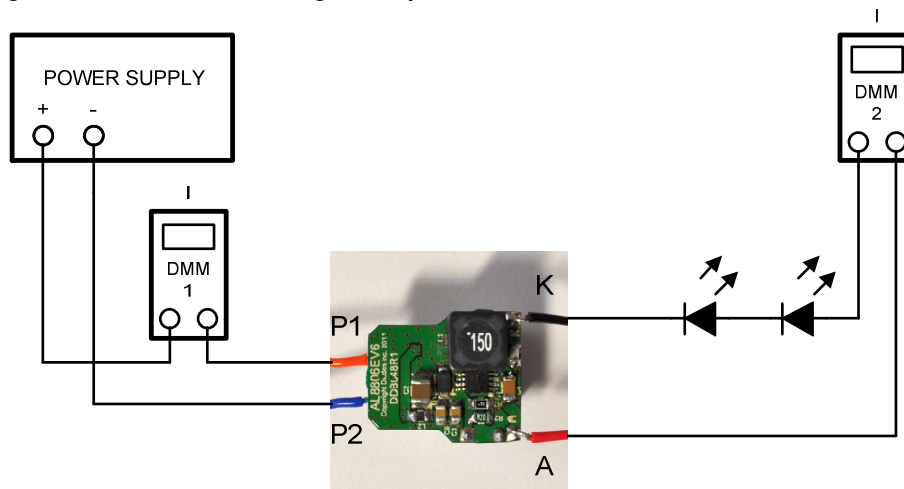

3. Cover the LEDs to avoid dazzling.
4. Switch on the power supply. This should illuminate the LEDs. Note that the input current (DMM1) is approximately 690mA. The output current (DMM2) is approximately 1.12A. The input voltage can be varied from approximately 9VDC to 30VDC and the current regulation observed is typically within $\pm 2\%$.

Observe Switching Waveform

- 5. The switching waveform can be observed on an oscilloscope.
- 6. Set the oscilloscope as follows:
Channel 1 sensitivity: 2V/div (at probe tip)
Time base: 1µs/div
Trigger Source: CH1
Trigger Mode: Auto
- 7. Connect the ground lead of a 10x probe to the supply negative terminal near P2 of the AL8006EV2, and touch the probe tip onto the anode of D1 as in **Figure 2** below. On the oscilloscope, press RUN/STOP to capture the waveform. The cursor readout indicates a switching frequency of 440kHz approximately.

Figure 2:

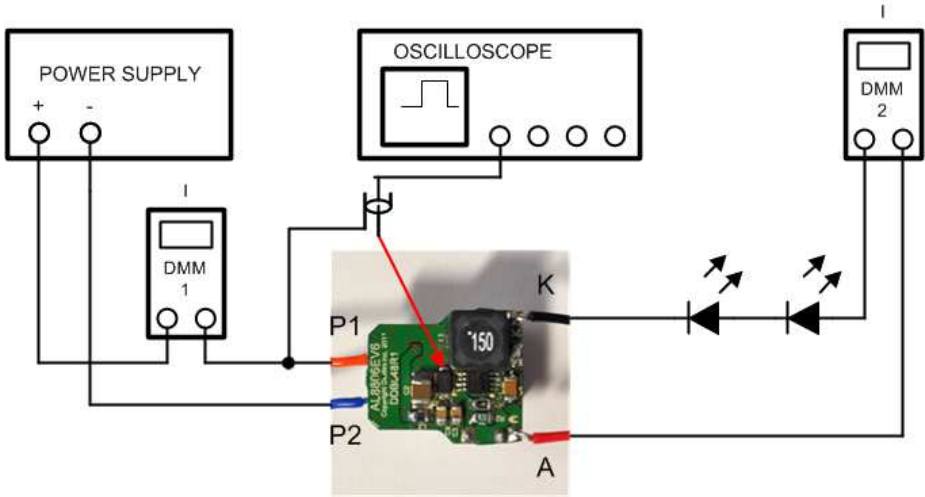
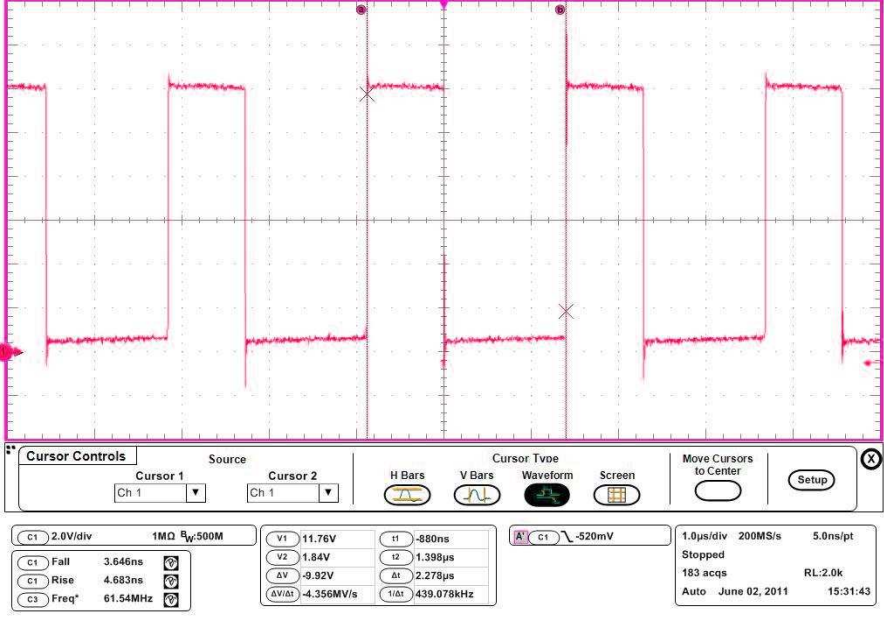
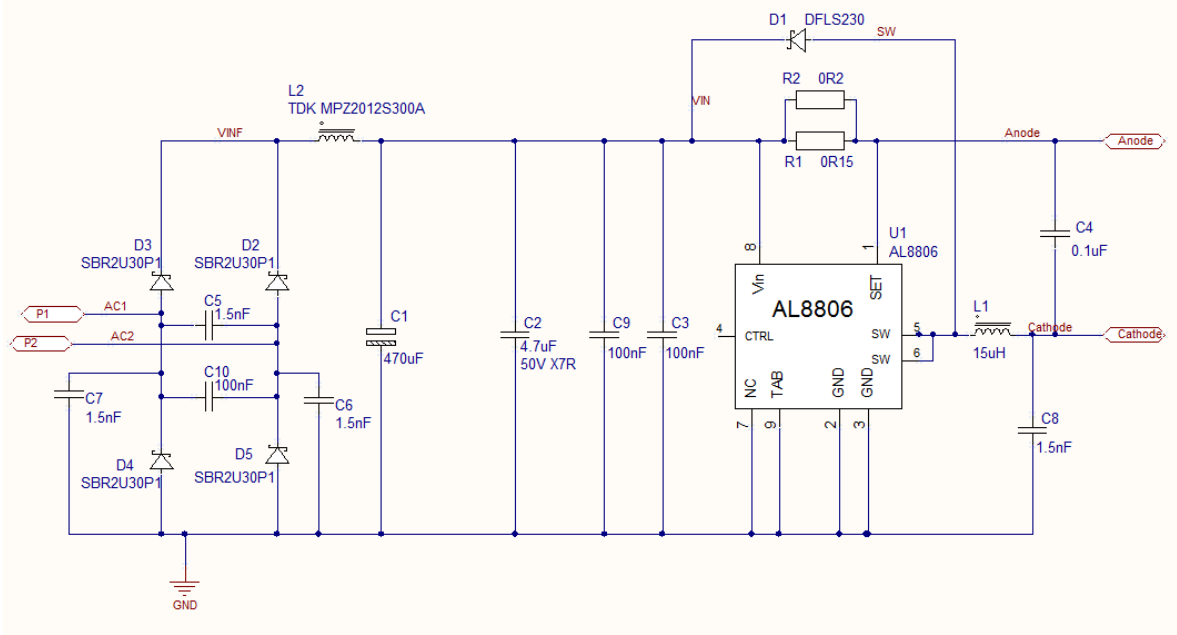

Figure 3: Oscilloscope Waveform



AL8806EV6 Schematic



PCB Copper Layout & Silk Screen – Top

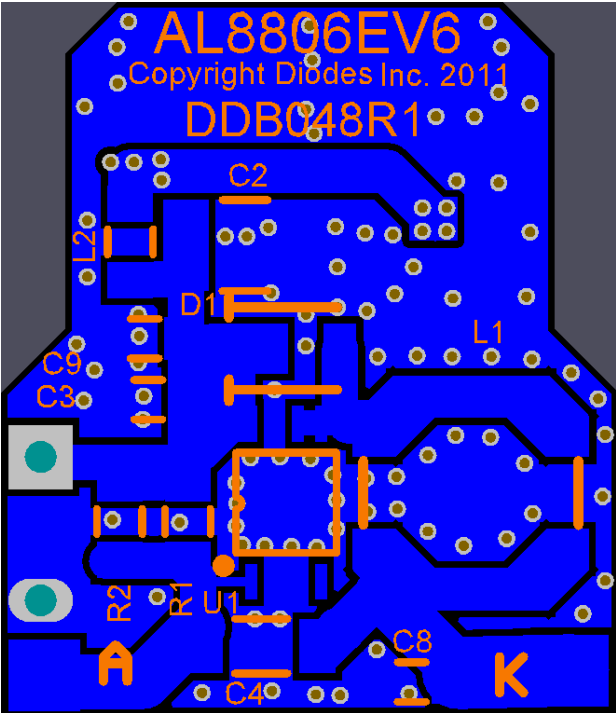

PCB Copper Layout & Silk Screen –Bottom

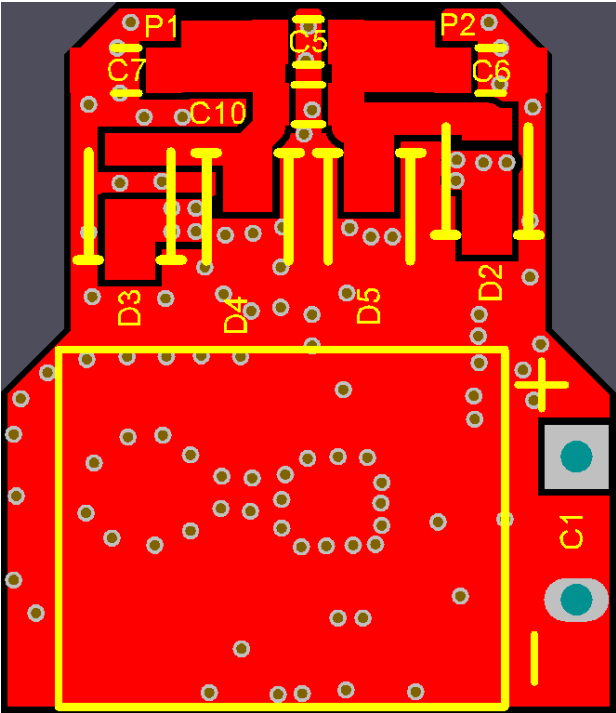

Parts List

Count	Designator	Description	Package	Manufacturer	Part Number
1	C1	Capacitor, 470uF, 25V Aluminium Electrolytic	Radial, 10 x 12.5mm	Rubycon	25ZLH470M
1	C2	Capacitor, 4.7uF 10% 50V X7R	1210	Kemet	C1210X475K5RAC
3	C3 C9 C10	Capacitor, 100nF 10% 50V X7R	0805	Kemet NIC	C1210X475K5RAC NMC0805X7R104K50TRPF
1	C4	Capacitor, 100nF 10% 50V X7R	1206	Kemet NIC	C1206104K5RAC7800 NMC1206X7R104K50TRPF
4	C5 - C8	Capacitor, 1.5nF 10% 50V or 100V, COG	0805	generic	
1	L1	Inductor, shielded, 15uH 20%	6.6 x 6.6mm	Coilcraft NIC Würth	MSS7341-153ML NPIS64D150MTRF 744777115
1	L2	Inductor, ferrite bead, 6A, 30ohms @100MHz	0805	TDK	MPZ2012S300A
1	R1	Resistor, 0.15ohms 1% 250ppm 125mW	0805	generic	
1	R2	Resistor, 0.2ohms 1% 250ppm 125mW	0805	generic	
1	D1	Diode, schottky, 30V 2A DFSL230 (alternatives: DFSL230L or LH)	PowerDi123	Diodes Inc	DFSL230-7
4	D2 - D5	Diode, Super Barrier Rectifier, 30V 2A SBR2U30	PowerDi123	Diodes Inc	SBR2U30P1-7
1	U1	IC, LED Driver, AL8806	MSOP-8EP	Diodes Inc	AL8806MP8-13

I/O

Count	Designator	Description	Function	Manufacturer	Part Number
1	P1	Solder pad	VDC, VAC Input		
1	P2	Solder pad	VDC, VAC Input		
1	A	Solder pad	LED Anode load		
1	K	Solder pad	LED Cathode load		

Recommended Operating Conditions

Symbol	Parameter	Min	Max	Units
VDC	Input Supply Voltage, VDC	8	30	V
VAC	Input Supply Voltage, VAC	8	20	Vrms
VOUT	Load voltage (1 to 3 LEDs)	0	10	V
T _A	Operating Ambient Temperature	-40	+105	°C

Current Setting

The LED current is set by the sense resistor value, R_{SENSE} . On this PCB, there are two resistors in parallel.

$$R_{\text{SENSE}} = R_1 * R_2 / (R_1 + R_2)$$

For the schematic values this gives a resistance of $0.15 * 0.2 / (0.15 + 0.2) = 0.0857$ ohms.

The LED current flows through R_{SENSE} . The sense voltage is 100mV, so the LED current is simply

$$I_{\text{LED}} = 0.1 / R_{\text{SENSE}}$$

For the schematic values this gives an LED current of $0.1/0.0857 = 1.167$ A nominally. In practice there is a slight reduction in current partly due to the resistance of the PCB copper, depending on the PCB layout. At 1.1A this reduction is typically about 5% using AL8806EV6.

The following table gives commercially available resistor values for typical current requirements, allowing a current error of 3% maximum not including the effect of PCB copper. A power limit of 125mW is assumed for the 0805 size resistors with 50% de-rating.

LED Current	R1, ohms	R2, ohms
150mA	0.68	DO NOT FIT
300mA	0.33	DO NOT FIT
380mA	0.51	DO NOT FIT
500mA	0.2	DO NOT FIT
660mA	0.15	DO NOT FIT
1A	0.2	0.2
1.1A	0.15	0.2

Performance

The performance of the AL8806EV6 demonstrated shows the capability to regulate LED current. The LED current of 1.1A is approximately 5% lower than the calculated value. This is partly due to copper resistance. With a load of 2 LEDs, the current changes by less than $\pm 2\%$ over the input voltage range from 9VDC to 30VDC. With 2 LEDs and a supply of 12VDC, the switching frequency is approximately 440kHz.

For further advice, please contact your local Diodes Field Applications Engineer, or one of our sales offices listed on the back page of this document.

IMPORTANT NOTICE

DIODES INCORPORATED MAKES NO WARRANTY OF ANY KIND, EXPRESS OR IMPLIED, WITH REGARD TO THIS DOCUMENT, INCLUDING, BUT NOT LIMITED TO, THE IMPLIED WARRANTIES OF MERCHANTABILITY AND FITNESS FOR A PARTICULAR PURPOSE (AND THEIR EQUIVALENTS UNDER THE LAWS OF ANY JURISDICTION).

Diodes Incorporated and its subsidiaries reserve the right to make modifications, enhancements, improvements, corrections or other changes without further notice to this document and any product described herein. Diodes Incorporated does not assume any liability arising out of the application or use of this document or any product described herein; neither does Diodes Incorporated convey any license under its patent or trademark rights, nor the rights of others. Any Customer or user of this document or products described herein in such applications shall assume all risks of such use and will agree to hold Diodes Incorporated and all the companies whose products are represented on Diodes Incorporated website, harmless against all damages.

Diodes Incorporated does not warrant or accept any liability whatsoever in respect of any products purchased through unauthorized sales channels. Should Customers purchase or use Diodes Incorporated products for any unintended or unauthorized application, Customers shall indemnify and hold Diodes Incorporated and its representatives harmless against all claims, damages, expenses, and attorney fees arising out of, directly or indirectly, any claim of personal injury or death associated with such unintended or unauthorized application.

Products described herein may be covered by one or more United States, international or foreign patents pending. Product names and markings noted herein may also be covered by one or more United States, international or foreign trademarks.

LIFE SUPPORT

Diodes Incorporated products are specifically not authorized for use as critical components in life support devices or systems without the express written approval of the Chief Executive Officer of Diodes Incorporated. As used herein:

A. Life support devices or systems are devices or systems which:

1. are intended to implant into the body, or
2. support or sustain life and whose failure to perform when properly used in accordance with instructions for use provided in the labeling can be reasonably expected to result in significant injury to the user.

B. A critical component is any component in a life support device or system whose failure to perform can be reasonably be expected to cause the failure of the life support device or to affect its safety or effectiveness.

Customers represent that they have all necessary expertise in the safety and regulatory ramifications of their life support devices or systems, and acknowledge and agree that they are solely responsible for all legal, regulatory and safety-related requirements concerning their products and any use of Diodes Incorporated products in such safety-critical, life support devices or systems, notwithstanding any devices- or systems-related information or support that may be provided by Diodes Incorporated. Further, Customers must fully indemnify Diodes Incorporated and its representatives against any damages arising out of the use of Diodes Incorporated products in such safety-critical, life support devices or systems.

Copyright © 2011, Diodes Incorporated

www.diodes.com

Sales offices**The Americas**

3050 E. Hillcrest Drive
Westlake Village,
CA 91362-3154
Tel: (+1) 805 446 4800
Fax: (+1) 805 446 4850

Europe

Kustermannpark
Balanstraße 59,
D-81541 München
Germany
Tel: (+49) 894 549 490
Fax: (+49) 894 549 4949

Taiwan

7F, No. 50,
Min Chuan Road
Hsin-Tien
Taipei, Taiwan
Tel: (+886) 289 146 000
Fax: (+886) 289 146 639

Shanghai

Rm. 606, No.1158
Changning Road
Shanghai, China
Tel: (+86) 215 241 4882
Fax (+86) 215 241 4891

Shenzhen

Room A1103-04,
ANLIAN Plaza, #4018
Jintian Road
Futian CBD,
Shenzhen, China
Tel: (+86) 755 882 849 88
Fax: (+86) 755 882 849 99

Korea

6 Floor, Changhwa B/D,
1005-5 Yeongtong-dong,
Yeongtong-gu, Suwon-si,
Gyeonggi-do, Korea 443-813
Tel: (+82) 312 731 884
Fax: (+82) 312 731 885