



Chipsmall Limited consists of a professional team with an average of over 10 year of expertise in the distribution of electronic components. Based in Hongkong, we have already established firm and mutual-benefit business relationships with customers from,Europe,America and south Asia,supplying obsolete and hard-to-find components to meet their specific needs.

With the principle of "Quality Parts,Customers Priority,Honest Operation,and Considerate Service",our business mainly focus on the distribution of electronic components. Line cards we deal with include Microchip,ALPS,ROHM,Xilinx,Pulse,ON,Everlight and Freescale. Main products comprise IC,Modules,Potentiometer,IC Socket,Relay,Connector.Our parts cover such applications as commercial,industrial, and automotives areas.

We are looking forward to setting up business relationship with you and hope to provide you with the best service and solution. Let us make a better world for our industry!



Contact us

Tel: +86-755-8981 8866 Fax: +86-755-8427 6832

Email & Skype: info@chipsmall.com Web: www.chipsmall.com

Address: A1208, Overseas Decoration Building, #122 Zhenhua RD., Futian, Shenzhen, China



AL8807AEV1 EVALUATION BOARD USER GUIDE

DESCRIPTION

The AL8807AEV1, Figure 1, is a double sided evaluation board for the AL8807A step-down, or 'buck', LED driver with internal switch. The evaluation board is preset to drive 680mA into a single LED, or multiple LEDs, the maximum number of which depends on their total forward voltage drop and the supply voltage. (The maximum drive current of the AL8807A is 1000mA)

The operating voltage of the board is nominally 36 volts, but it can be reduced to a minimum of 6 volts. The 68uH inductor used in the circuit is based on this nominal supply. The evaluation board should be connected as in Figure 1 below.

Note: The evaluation board does not have reverse supply protection.

The nominal current, 680mA, is set with the 0R15 sense resistor, R1.

Terminal CTRL provides a connection point for Analog dimming.

Warning: At 36V nominal operation with 680mA output, the LED will be hot and very bright

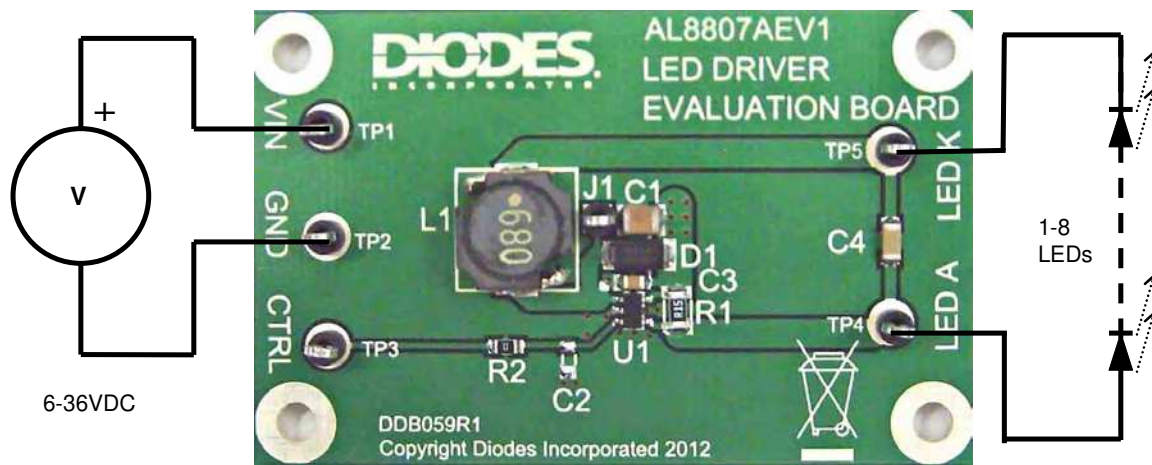

Figure 1: AL8807AEV1 evaluation board and connection diagram

AL8807AEV1 Connection Point Definition	
Name	Description
Vin	Positive supply voltage. 6 to 36V
GND	Supply Ground (0V).
CTRL	Internal voltage ref. pin (2.5V). This pin can be used to achieve dimming and for switching the output current off. Leave floating for normal operation.
LED A	LED A connects to the external LED anode
LED K	LED K connects to the external LED cathode

AL8807A DEVICE DESCRIPTION

The AL8807A is a continuous mode inductive driver in a SOT25 package, for driving one or more series-connected LEDs efficiently from a voltage source higher than the LED voltage. The device includes the output switch and a current sense circuit, which requires an external sense resistor to set the nominal current up to 1000mA.

AL8807A DEVICE FEATURES

- Drives one or more series-connected LEDs
- LEDs up to 1000mA.
- Internal 36V switch.
- Wide input voltage: 6V to 36V.
- Inherent open circuit LED protection.
- Brightness control using DC.

DEVICE APPLICATIONS

- LED flashlights.
- High Power LED driving.
- Low-voltage halogen replacement LEDs.
- Automotive lighting.
- Illuminated signs.

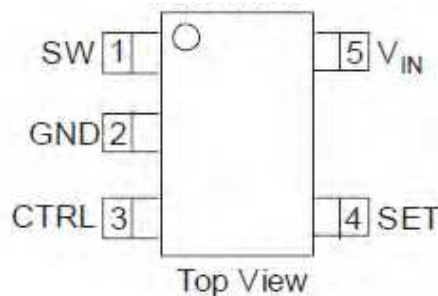
AL8807A Device Packages, Pin and Definitions**SOT25 pack****AL8807A Device Pin Definition**

Name	Pin No	Description
SW	1	Drain of NDMOS switch.
GND	2	Ground (0V).
CTRL	3	Internal voltage ref. pin (2.5V) : <ul style="list-style-type: none"> • Leave floating for normal operation. • Drive with a DC voltage (0.25V to 2.5V to adjust output current
SET	4	Connect a sense resistor, R1, from the SET pin to VIN to sense the nominal output current. Nominal $I_{out} = 0.1 / R1$
VIN	5	Input voltage: 6V to 36V. Decouple to ground with a 2.2uF or higher ceramic capacitor.

ORDERING INFORMATION

EVALBOARD ORDER NUMBER
AL8807AEV1

DEVICE ORDER NUMBER
AL8807AW5-7

Please note: Evaluation boards are subject to availability and qualified sales leads.

AL8807AEV1 EVALUATION BOARD REFERENCE DESIGN

The AL8807AEV1 is configured to the reference design in Figure 2.

The operating voltage is a nominal 36V. The nominal current is set at 680mA with a 0R15 sense resistor R1. The circuit operates in continuous mode at approximately 188kHz, with a 68uH inductor and one LED.

For Analog dimming, the CTRL pin may be driven between 0.25V and 2.5V adjusting the output current from approximately 10% to 100% of I_{LED} . Shorting R3 will connect the test pin CTRL directly to device pin CTRL, if required.

For other reference designs or further applications information, please refer to the AL8807A datasheet.

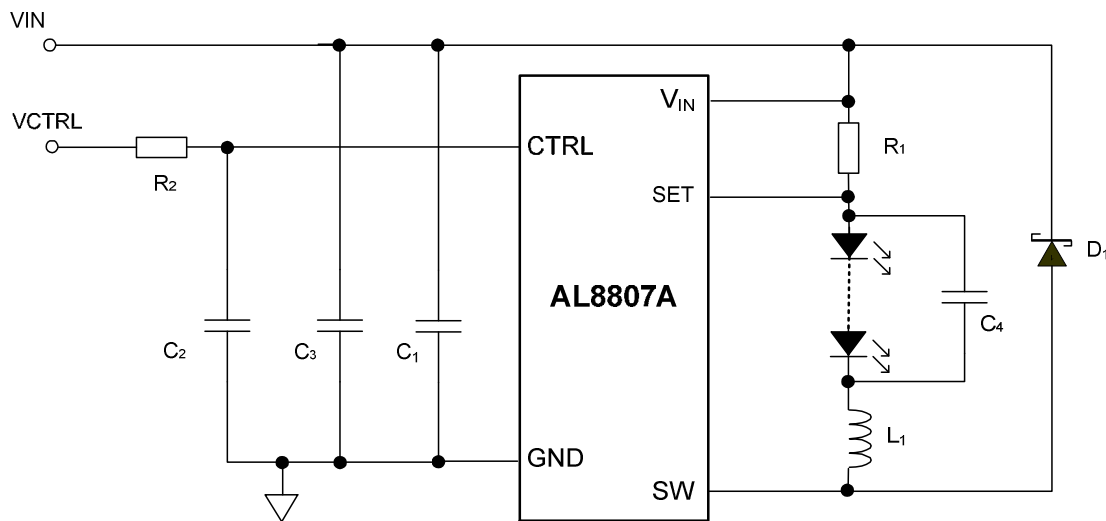

Figure 2: Schematic diagram

AL8807A Operation

In normal operation, when a voltage is applied at +Vin, the AL8807A internal NDMOS switch is turned on. Current starts to flow through sense resistor R1, inductor L1, and the LED. The current ramps up linearly, the ramp rate being determined by the input voltage +Vin and the inductor L1. This rising current produces a voltage ramp across R1. The internal circuit of the AL8807A senses the voltage across R1 and applies a proportional voltage to the input of the internal comparator. When this voltage reaches an internally set upper threshold, the NDMOS switch is turned off. The inductor current continues to flow through R1, L1, the LED and the Schottky diode D1, and back to the supply rail, but it decays, with the rate of decay determined by the forward voltage drop of the LEDs and the Schottky diode. This decaying current produces a falling voltage at R1, which is sensed by the AL8807A. A voltage proportional to the sense voltage across R1 is applied at the input of the internal comparator. When this voltage falls to the internally set lower threshold, the NDMOS switch is turned on again. This switch-on-and-off cycle continues to provide the average LED current set by the sense resistor R1. Please refer to the datasheets for the threshold limits, AL8807A internal circuits, electrical characteristics and parameters.

AL8807AEV1 Component list

Ref	Value	Package	Part Number	Manufacturer	Notes
U1	AL8807A	SOT25	AL8807AE5TA	Diodes	DC-DC converter
D1	40V, 3A		B240A	Diodes	Schottky diode
R1	0R15	0805		Generic	5%
R2,	0R0	0805		Generic	1%
C1	4.7uF 50V	1210	C1210X475K5RAC	Generic KEMET	X7R
C2	Not Fitted				Optional soft start capacitor
C3	100nF, 100V	0805	NMC0805X7R104K100 PF GRM21BR71H104KA01L	Generic NIC Comps MURATA	X7R
C4	100nF 100V	1206	NMC1206X7R104K100	Generic NIC Comps	X7R
L1	68uH		MSS1038-683ML NPIS24H680MTRF NPIS104F680MTRF	Coilcraft NIC Comps	

Note: The component part numbers are correct at the time of publication. Diodes Inc reserves the right to substitute other parts where necessary, without further notification.

AL8807AEV1 Basic operation at full voltage

1. Connect Vin and GND
Warning: The board does not feature reverse battery/supply protection.
2. Set the PSU to 36V
3. Turn on the PSU and the LED will illuminate and the current should be approximately 680mA.
Warning: Do not stare at the LED directly.

Minimising the output current

Shorting the CTRL pin to GND will cause the LED current to be reduced. On some boards, however, the LED may not be completely turned off.

Soft start

Adding a C2 capacitor will create a soft-start power-up sequence (0.1ms/nF).

Changing the LED current

1. Remove R1.
2. Calculate and replace sense resistor, R1, the value of which is based on the required LED current without dimming. R1 can be calculated using following equation :

$$R1 = 0.1V/I_{OUT}$$

where I_{OUT} = the LED current.

R1 = the sense resistor value in ohms.

0.1V is the nominal sense voltage with 'CTRL' open circuit or set to 2.5V.

The device calculator at the address below can be used to speed up the redesign phase:

<http://www.diodes.com/destools/calculators.html>

PERFORMANCE

The system efficiency depends on the sense resistor, supply voltage, switching frequency and the number of LEDs.

With a 36V supply and one LED, the switching frequency is typically 188kHz.

The efficiency level is >85% .

For further advice, please contact your local Diodes Field Applications Engineer, or one of our sales offices listed on the back page of this document.

INTENTIONALLY BLANK

INTENTIONALLY BLANK

IMPORTANT NOTICE

DIODES INCORPORATED MAKES NO WARRANTY OF ANY KIND, EXPRESS OR IMPLIED, WITH REGARD TO THIS DOCUMENT, INCLUDING, BUT NOT LIMITED TO, THE IMPLIED WARRANTIES OF MERCHANTABILITY AND FITNESS FOR A PARTICULAR PURPOSE (AND THEIR EQUIVALENTS UNDER THE LAWS OF ANY JURISDICTION).

Diodes Incorporated and its subsidiaries reserve the right to make modifications, enhancements, improvements, corrections or other changes without further notice to this document and any product described herein. Diodes Incorporated does not assume any liability arising out of the application or use of this document or any product described herein; neither does Diodes Incorporated convey any license under its patent or trademark rights, nor the rights of others. Any Customer or user of this document or products described herein in such applications shall assume all risks of such use and will agree to hold Diodes Incorporated and all the companies whose products are represented on Diodes Incorporated website, harmless against all damages.

Diodes Incorporated does not warrant or accept any liability whatsoever in respect of any products purchased through unauthorized sales channels. Should Customers purchase or use Diodes Incorporated products for any unintended or unauthorized application, Customers shall indemnify and hold Diodes Incorporated and its representatives harmless against all claims, damages, expenses, and attorney fees arising out of, directly or indirectly, any claim of personal injury or death associated with such unintended or unauthorized application.

Products described herein may be covered by one or more United States, international or foreign patents pending. Product names and markings noted herein may also be covered by one or more United States, international or foreign trademarks.

LIFE SUPPORT

Diodes Incorporated products are specifically not authorized for use as critical components in life support devices or systems without the express written approval of the Chief Executive Officer of Diodes Incorporated. As used herein:

A. Life support devices or systems are devices or systems which:

1. are intended to implant into the body, or
2. support or sustain life and whose failure to perform when properly used in accordance with instructions for use provided in the labeling can be reasonably expected to result in significant injury to the user.

B. A critical component is any component in a life support device or system whose failure to perform can be reasonably be expected to cause the failure of the life support device or to affect its safety or effectiveness.

Customers represent that they have all necessary expertise in the safety and regulatory ramifications of their life support devices or systems, and acknowledge and agree that they are solely responsible for all legal, regulatory and safety-related requirements concerning their products and any use of Diodes Incorporated products in such safety-critical, life support devices or systems, notwithstanding any devices- or systems-related information or support that may be provided by Diodes Incorporated. Further, Customers must fully indemnify Diodes Incorporated and its representatives against any damages arising out of the use of Diodes Incorporated products in such safety-critical, life support devices or systems.

Copyright © 2012, Diodes Incorporated

www.diodes.com

Sales offices**The Americas**

3050 E. Hillcrest Drive
Westlake Village,
CA 91362-3154
Tel: (+1) 805 446 4800
Fax: (+1) 805 446 4850

Europe

Kustermannpark
Balanstraße 59,
D-81541 München
Germany
Tel: (+49) 894 549 490
Fax: (+49) 894 549 4949

Taiwan

7F, No. 50,
Min Chuan Road
Hsin-Tien
Taipei, Taiwan
Tel: (+886) 289 146 000
Fax: (+886) 289 146 639

Shanghai

Rm. 606, No.1158
Changning Road
Shanghai, China
Tel: (+86) 215 241 4882
Fax (+86) 215 241 4891

Shenzhen

Room A1103-04,
ANLIAN Plaza, #4018
Jintian Road
Futian CBD,
Shenzhen, China
Tel: (+86) 755 882 849 88
Fax: (+86) 755 882 849 99

Korea

6 Floor, Changhwa B/D,
1005-5 Yeongtong-dong,
Yeongtong-gu, Suwon-si,
Gyeonggi-do, Korea 443-813
Tel: (+82) 312 731 884
Fax: (+82) 312 731 885