



Chipsmall Limited consists of a professional team with an average of over 10 year of expertise in the distribution of electronic components. Based in Hongkong, we have already established firm and mutual-benefit business relationships with customers from,Europe,America and south Asia,supplying obsolete and hard-to-find components to meet their specific needs.

With the principle of “Quality Parts,Customers Priority,Honest Operation,and Considerate Service”,our business mainly focus on the distribution of electronic components. Line cards we deal with include Microchip,ALPS,ROHM,Xilinx,Pulse,ON,Everlight and Freescale. Main products comprise IC,Modules,Potentiometer,IC Socket,Relay,Connector.Our parts cover such applications as commercial,industrial, and automotives areas.

We are looking forward to setting up business relationship with you and hope to provide you with the best service and solution. Let us make a better world for our industry!



Contact us

Tel: +86-755-8981 8866 Fax: +86-755-8427 6832

Email & Skype: info@chipsmall.com Web: www.chipsmall.com

Address: A1208, Overseas Decoration Building, #122 Zhenhua RD., Futian, Shenzhen, China



Description

The AL8822 is a boost converter that delivers an accurate constant current for MR16 and similar LED Lamps. With proprietary control scheme, the LED driver is compatible with many commonly used electronic transformers and provides designs with High Power Factor (PF) and low Total Harmonic Distortion (THD) for these applications. The operation frequency is up to 1MHz that allows the use of a small size inductor. With the package of SO-8EP, the AL8822 has small package size, small thermal resistance and can be used for wide range of output power. The driver can be used for dimmable MR16 application and can be compatible with leading-edge dimmer and trailing-edge dimmer.

Features

- Wide Input Voltage Range: 5V to 36V
- Internal 50V NDMOS Switches
- Continuous Conduction Mode (CCM) Operation
- Up to 1MHz Switching Frequency
- High PF > 0.9 and Low THD < 30% and Low Ripple < 20%
- Compatible with Leading-edge Dimmer and Trailing-edge Dimmer
- Internal Protections
 - Under Voltage Lock Out (UVLO)
 - Output Open Protection
 - Over Temperature Protection (OTP)
- Pb-free SO-8EP
- **Totally Lead-Free & Fully RoHS Compliant (Notes 1 & 2)**
- **Halogen and Antimony Free. "Green" Device (Note 3)**

Pin Assignments

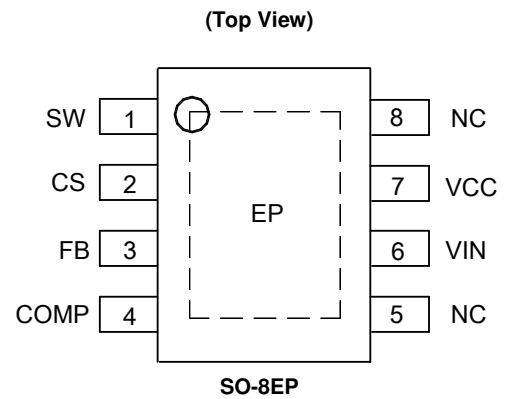

Applications

- Non-dimmable MR16 Lamps
- Dimmable MR16 Lamps
- General Illumination Lamps

- Notes:
1. No purposely added lead. Fully EU Directive 2002/95/EC (RoHS), 2011/65/EU (RoHS 2) & 2015/863/EU (RoHS 3) compliant.
 2. See <https://www.diodes.com/quality/lead-free/> for more information about Diodes Incorporated's definitions of Halogen- and Antimony-free, "Green" and Lead-free.
 3. Halogen- and Antimony-free "Green" products are defined as those which contain <900ppm bromine, <900ppm chlorine (<1500ppm total Br + Cl) and <1000ppm antimony compounds.

Typical Applications Circuit

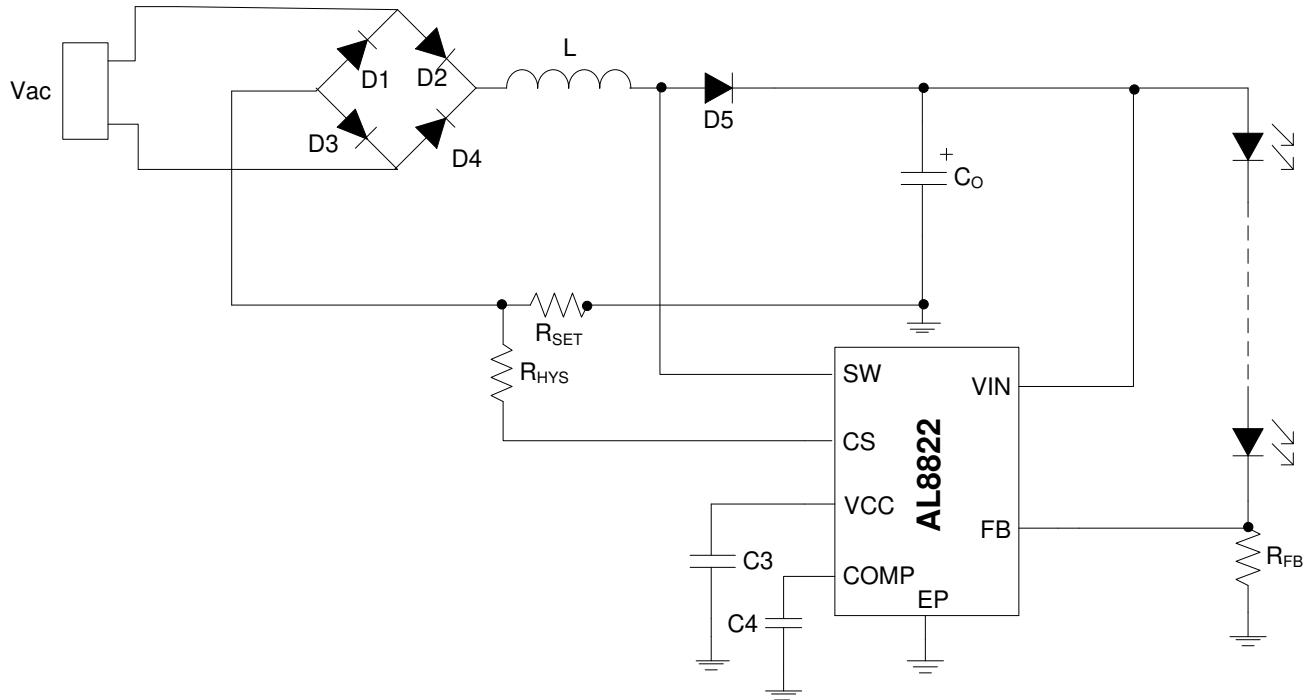

The AL8822 Boost Application Circuit

Pin Descriptions

Pin Number	Pin Name	Function
1	SW	Integrated MOS Drain
2	CS	Input Current Sense Pin
3	FB	LED Output Current Feedback Pin
4	COMP	Control Loop Compensation Pin
5	NC	Not Connected
6	VIN	IC Input Voltage, Adding from Boost Output Voltage
7	VCC	Supply Voltage For Internal Circuit
8	NC	Not Connected
9	EP	Exposed pad that connect to GND.

NEW PRODUCT

Functional Block Diagram

NEW PRODUCT

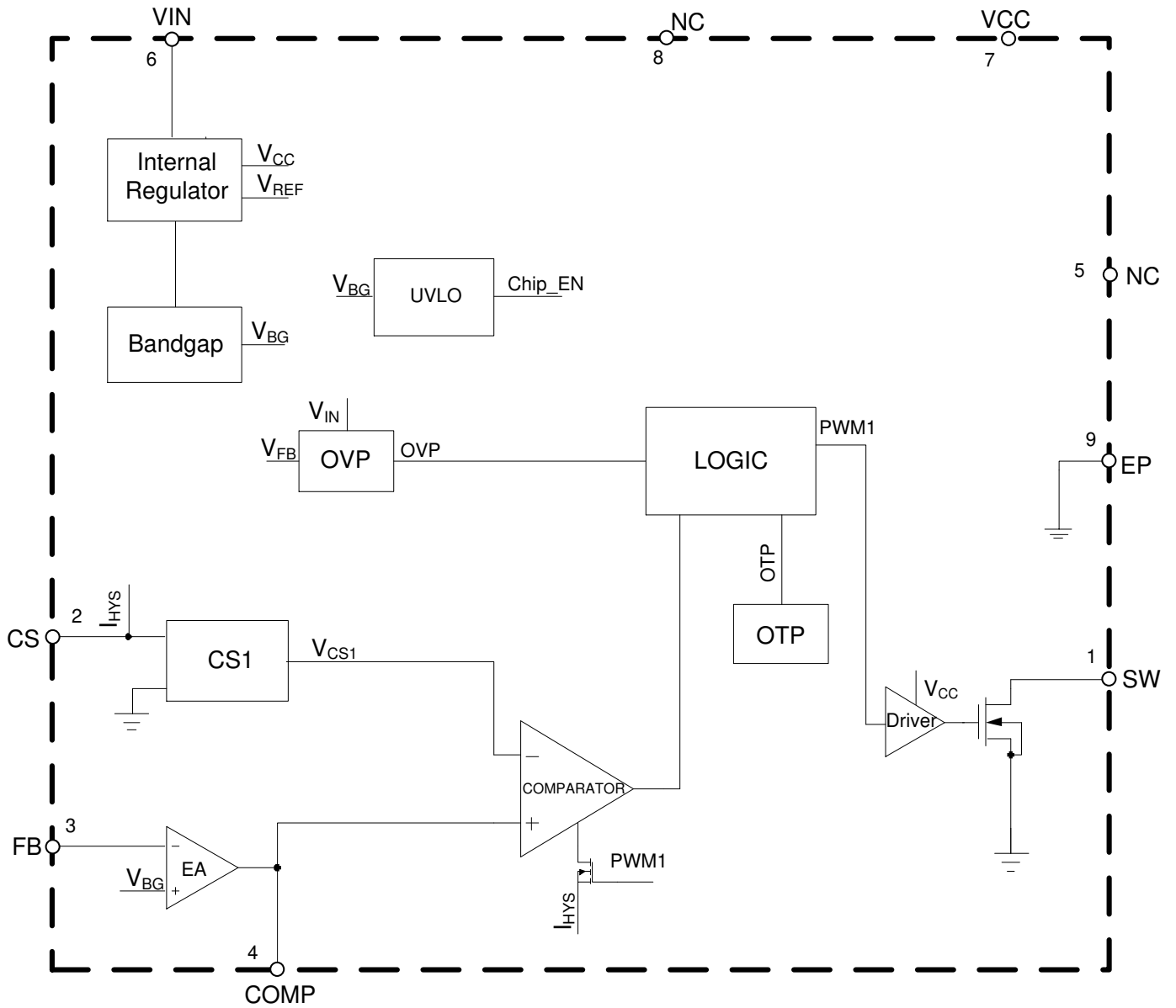

AL8822 Block Diagram

Absolute Maximum Ratings (@ $T_A = +25^\circ\text{C}$, unless otherwise specified. Note 4)

Symbol	Parameter	Rating	Unit
V_{IN}	VIN Pin Voltage	-0.3 to 40	V
V_{SW}	SW Pin Voltage	-0.3 to 50	V
V_{COMP}	COMP Pin Voltage	-0.3 to 6	V
V_{CS}	CS Pin Voltage	-0.3 to 6	V
V_{FB}	FB Pin Voltage	-0.3 to 6	V
V_{CC}	VCC Pin Voltage	-0.3 to 6	V
T_J	Operating Junction Temperature	+150	$^\circ\text{C}$
T_{STG}	Storage Temperature	-65 to +150	$^\circ\text{C}$
θ_{JA}	Thermal Resistance (Junction to Ambient) (Note 5)	66	$^\circ\text{C}/\text{W}$
T_{LEAD}	Lead Temperature (Soldering, 10s)	+300	$^\circ\text{C}$
–	ESD (Machine Model)	200	V
–	ESD (Human Body Model)	2000	V

- Notes:
- Stresses greater than those listed under “Absolute Maximum Ratings” may cause permanent damage to the device. These are stress ratings only and functional operation of the device at these or any other conditions beyond those indicated under “Recommended Operating Conditions” is not implied. Exposure to “Absolute Maximum Ratings” for extended periods may affect device reliability.
 - Device mounted on FR-4 PCB (51mm x 51mm) 2oz copper, minimum recommended pad layout on top layer and thermal vias to bottom layer ground plane. For better thermal performance, larger copper pad for heat-sink is needed.

Recommended Operating Conditions

Symbol	Parameter	Min	Max	Unit
V_{IN}	VIN Pin Voltage	5	36	V
T_A	Ambient Temperature (Note 6)	-40	+105	$^\circ\text{C}$

- Note: 6. The device may operate normally at +125 $^\circ\text{C}$ ambient temperature under the condition not trigger temperature protection.

Electrical Characteristics (@T_A = +25°C, unless otherwise specified.)

Symbol	Parameter	Condition	Min	Typ	Max	Unit
Input Supply						
V _{IN}	VIN Pin Voltage	–	5	–	36	V
I _Q	Quiescent Current	No Switching	–	1	–	mA
V _{UVLO}	Under-Voltage Lockout Voltage	V _{IN} Rising	–	4.2	–	V
V _{HYS}	UVLO Hysteresis	–	–	500	–	mV
VCC Regulator						
V _{CC}	VCC Pin Voltage	–	4.5	5	5.5	V
–	Source Current Capability	V _{CC} = 5V	10	–	–	mA
–	Load Regulation	–	–	4	–	%
Integrated NMOS_BOOST						
V _{DS}	MOS Voltage Stress (Note 7)	–	50	–	–	V
I _{DS}	MOS Current Stress (Note 7)	–	–	2	–	A
R _{DSON}	MOS R _{DSON}	–	–	250	500	mΩ
Compensation and Soft Start (COMP Pin)						
G _{EA}	Error Amplifier Trans-conductance	–	–	1000	–	μA/V
I _{O-H}	Sourcing Current	V _{COMP} = 0.5V	–	68	–	μA
I _{O-L}	Sinking Current	V _{COMP} = 4.5V	–	68	–	μA
V _{FB}	FB Pin Voltage	–	430	444	458	mV
Hysteresis Comparator						
V _{CS_MIN}	Boost Sense Voltage Low Level	V _{COMP} = 0V	–	-90	–	mV
I _{HYS}	Hysteresis Current	–	85	100	115	μA
Over-Temperature Protection						
T _{OTSD}	Thermal Shutdown (Note 7)	–	–	+160	–	°C
T _{HYS}	Thermal Shutdown Hysteresis (Note 7)	–	–	+40	–	°C

Note: 7. Guaranteed by design, not tested in production.

Performance Characteristics

Quiescent Current vs. VIN Pin Voltage

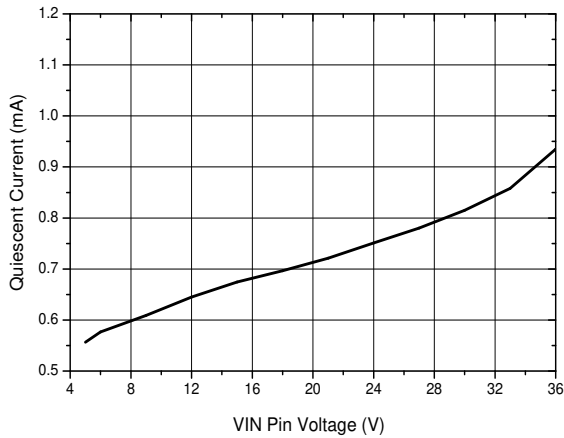

Quiescent Current vs. Ambient Temperature

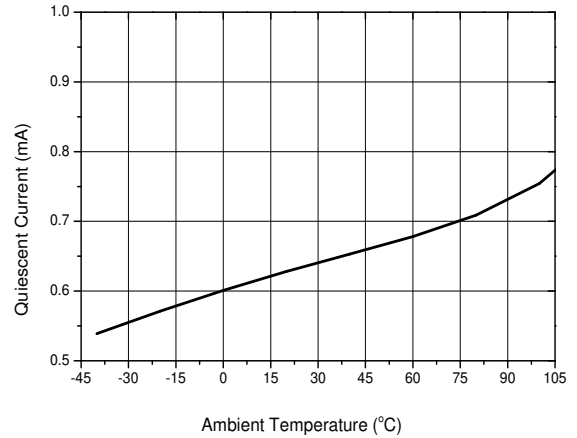

Under-Voltage Lockout Voltage vs. VIN Pin Voltage

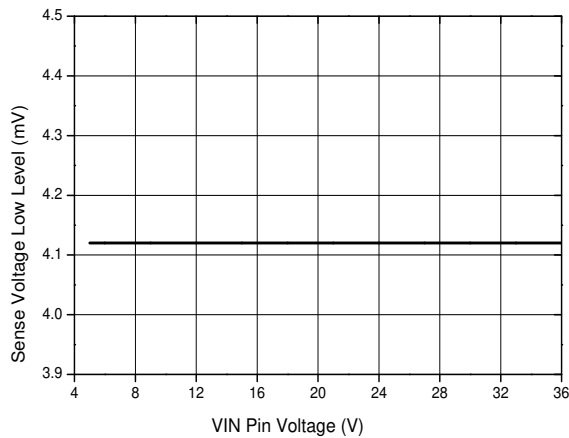

Under-Voltage Lockout Voltage vs. Ambient Temperature

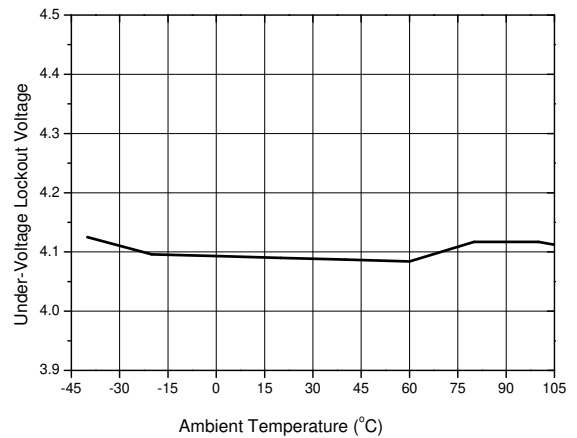

FB Pin Voltage vs. VIN Pin Voltage

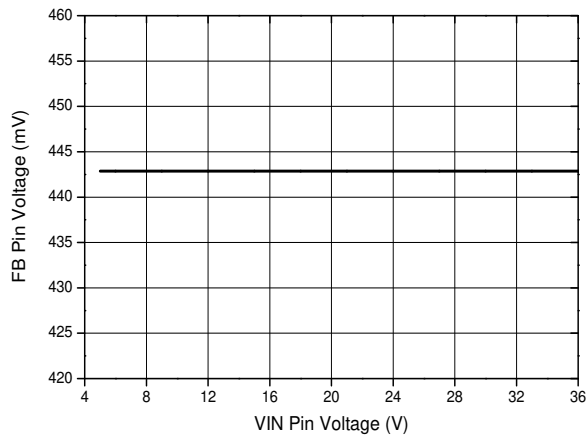

FB Pin Voltage vs. Ambient Temperature

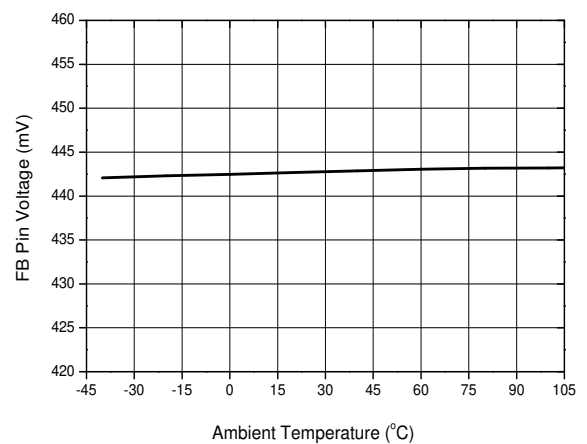

Performance Characteristics (Cont.)

Boost Sense Voltage Low Level vs. VIN Pin Voltage

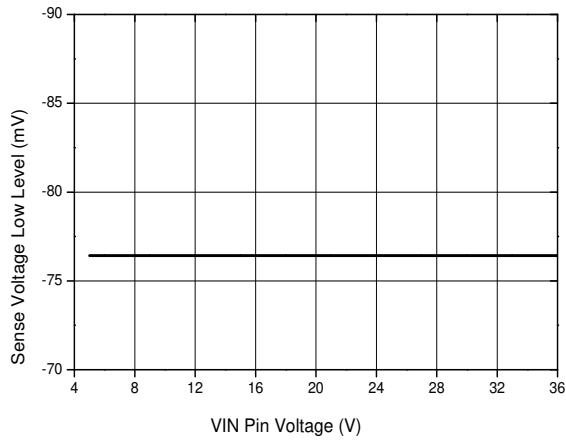

Boost Sense Voltage Low Level vs. Ambient Temperature

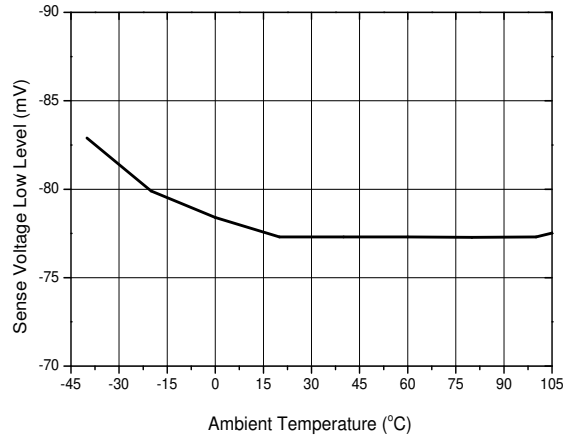

Hysteresis Current vs. VIN Pin Voltage

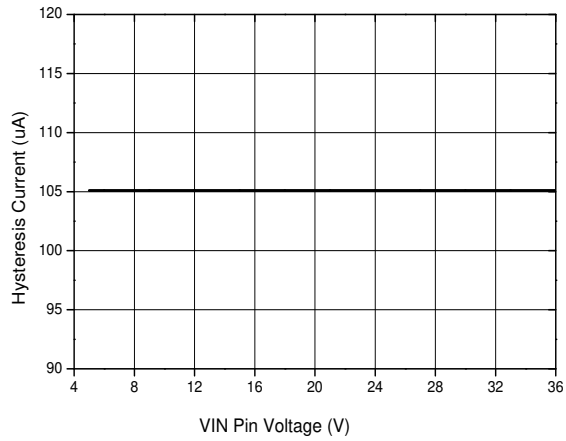

Hysteresis Current vs. Ambient Temperature

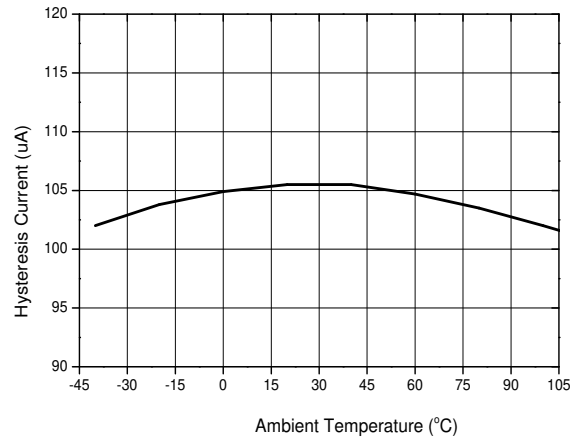

NEW PRODUCT

Application Information

Operation

The AL8822 is a boost converter that delivers an accurate constant current for driving LEDs. With hysteretic control scheme, the LED driver is compatible with most of commonly used electronic transformers. The driver can be compatible with leading-edge dimmer and trailing-edge dimmer.

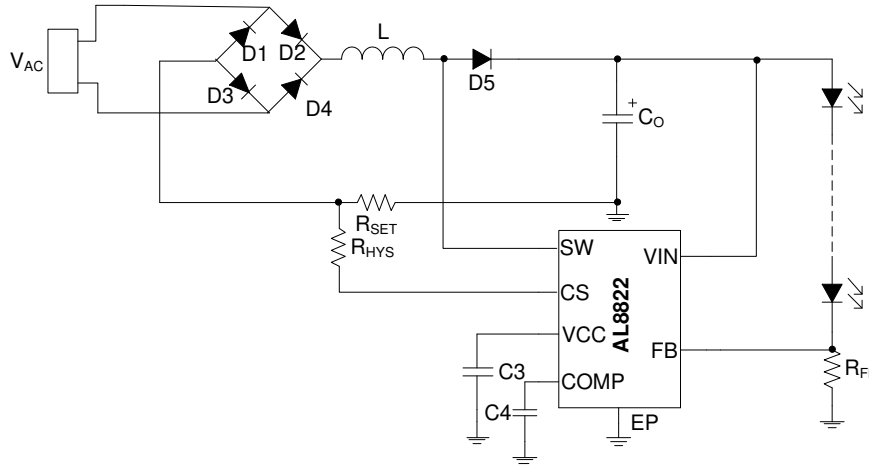

Figure 1. Typical Application Circuit

LED Current Control

The LED current is controlled by the resistor R_{FB} in Figure 1.

Connected between FB pin and Ground, the nominal average output current in the LED(s) is defined as:

$$I_{LED} = \frac{0.444}{R_{FB}}$$

R_{SET} and R_{HYS} Setting

The Boost converter of the AL8822 operates at continuous conduction mode and is based on hysteresis schematic which has lower threshold and upper threshold. Refer to Figure 2 depicting the inductor current waveform.

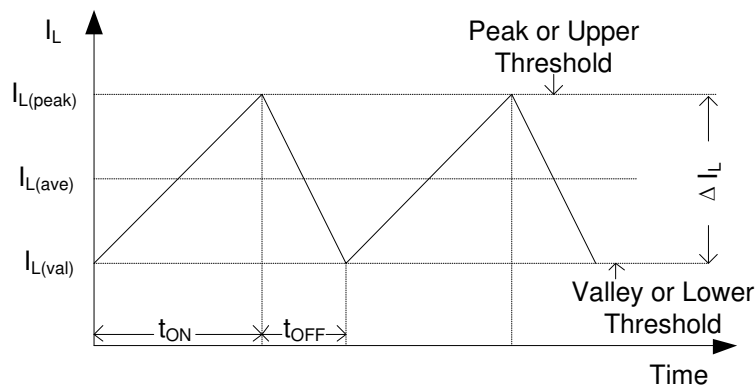

Figure 2. Inductor Current

When switch SW is turned on, the inductor current flows through R_{SET} and ramps up linearly. The rising current produces a voltage ramp across R_{SET} . When the voltage across R_{SET} reaches the upper threshold, switch SW is turned off. The inductor current continues to flow through R_{SET} but decays. The decaying current produces a falling voltage at R_{SET} . When the voltage across R_{SET} falls to the lower threshold, switch SW is turned on again.

The lower threshold voltage V_{LT} depends on the voltage V_{COMP} at COMP pin that varies with the input voltage and output load. The equation is shown as below.

Application Information (Cont.)

$$V_{LT} = \begin{cases} \frac{(V_{COMP} - 1.5) \times 0.6 + 1.4}{16} V, & 1.5V \leq V_{COMP} \leq 5V \\ 0.088V, & 0V \leq V_{COMP} \leq 1.5V \end{cases}$$

The range of V_{COMP} is from 0V to 5V.

The upper threshold depends on the lower threshold and the hysteresis value. The hysteresis value is set by external resistor R_{HYS} . It is defined as below.

$$V_{HYS} = R_{HYS} \times 100\mu A$$

According to the operation principle, the peak to peak current ΔI_L and the valley current $I_{L(val)}$ can be obtained by the below equations.

$$I_{L(val)} = \frac{V_{LT}}{R_{SET}}$$

$$\Delta I_L = \frac{V_{HYS}}{R_{SET}}$$

Where:

ΔI_L is the peak to peak current of inductor.

$I_{L(val)}$ is the valley current of inductor.

From the Figure 2, the relationship between $I_{L(peak)}$, $I_{L(val)}$, $I_{L(ave)}$ and ΔI_L can be obtained as below.

$$I_{L(peak)} = I_{L(val)} + \Delta I_L$$

$$I_{L(ave)} = I_{L(val)} + \frac{1}{2} \times \Delta I_L$$

Where:

$I_{L(peak)}$ is the peak current of inductor.

$I_{L(ave)}$ is the average current of inductor.

As we know the average current $I_{L(ave)}$ depends on the output power, rated input voltage V_{IN1} of step-up converter and total efficiency η . So the average current $I_{L(ave)}$ can be obtained by the following equation.

$$I_{L(ave)} = \frac{(V_{LED} + 0.444) \times I_{LED}}{\eta \times V_{IN1}}$$

Where: V_{LED} is the voltage in LEDs.

Set ratio of ΔI_L to $I_{L(peak)}$ as K.

Application Information (Cont.)

$$K = \frac{\Delta I_L}{I_{L(peak)}}$$

R_{SET} and R_{HYS} can be obtained from above equations:

$$R_{SET} = \begin{cases} \frac{((V_{COMP} - 1.5) \times 0.6 + 1.4) \times (2 - K) \times \eta \times V_{IN1}}{32 \times (V_{LED} + 0.444) \times I_{LED} \times (1 - K)}, & 1.5V \leq V_{COMP} \leq 5V \\ \frac{0.044 \times (2 - K) \times \eta \times V_{IN1}}{(V_{LED} + 0.444) \times I_{LED} \times (1 - K)}, & 0V \leq V_{COMP} \leq 1.5V \end{cases}$$

$$R_{HYS} = \frac{2 \times (V_{LED} + 0.444) \times I_{LED} \times K \times R_{SET} \times 10^4}{\eta \times V_{IN1} \times (2 - K)}$$

When the value of K, η and V_{COMP} are provided, the value of resistor R_{SET} and R_{HYS} can be calculated according to above equations. In order to get appropriate efficiency and Electronic Transformer (ET) compatibility, generally K is set between 0.4 and 0.8. Due to the range of V_{COMP} is from 0V to 5V, in order to get output voltage regulation, generally V_{COMP} is set as 3V at rated input voltage.

Inductor Selection

Because of the using of the hysteretic control scheme, the switching frequency in a boost configuration can be adjusted in accordance to the value of the inductor being used. The value of the inductor can be determined on the desired switching frequency by using the following equation:

$$L = \frac{[V_{IN1} - (R_{SET} + R_L + R_{DS(on)}) \times I_{L(ave)}] \times [V_{LED} + 0.444 + V_F + (R_L + R_{SET}) \times I_{L(ave)} - V_{IN1}]}{\Delta I_L (V_{LED} + 0.444 + V_F - R_{DS(on)} \times I_{L(ave)}) \times f_{SW}}$$

Where:

L is the coil inductance.

R_L is the coil resistance.

R_{DS(on)} is the switch SW on resistance.

V_{IN1} is the rated input voltage.

V_F is the diode forward voltage.

f_{SW} is the desired switching frequency. Generally 500kHz to 800kHz switching frequency is suggested. Low switching frequency can decrease the switching loss but need to choose higher inductor values that will result in larger size in order to meet the saturation current. For example the relationship between switching frequency and inductor value is shown as below Table 1 in the same application system. Considering these factors, 500kHz switching frequency is recommend in typical application.

Inductance Value of L @ V _{AC} = 12V _{AC} , V _{IN} = 22V V _{LED} = 28V, I _{LED} = 180mA	Operation Frequency of SW at Peak Voltage Of V _{AC}
10μH	840kHz
15μH	800kHz
22μH	680kHz
33μH	465kHz

Table 1

Application Information (Cont.)

VIN OVP Protection

AL8822 has an internal over voltage protection to protect IC from excessive input voltage. When the voltage applied at VIN pin exceeds 39V, it will turn off the power switch SW. The power switch SW will be turned on again once the voltage at V_{IN} drops below 34V.

VCC Regulator

The VCC pin requires a capacitor C3 for stable operation and to store the charge for the large GATE switching currents. Choose a 10V rated low ESR, X7R or X5R, ceramic capacitor for best performance. A 4.7 μ F capacitor will be adequate for many applications. Place the capacitor close to the IC to minimize the trace length to the VCC pin and to the IC ground.

An internal current limit on the VCC output protects the excessive on-chip power dissipation. The VCC pin has set the output to 5V (typ.) to protect the internal FETs from excessive power dissipation caused by not being fully enhanced. If the VCC pin is used to drive extra circuits beside the , the extra loads should be limited to less than 8mA.

Output Capacitor Co

The capacitor C_O is used to hold the bus voltage and reduce the ripple of LED current when the electronic transformer has no output. For most applications, it is recommended to use an aluminum electrolytic capacitor with greater than 220 μ F capacitance.

Compensation Capacitor C4

In applications powered by electronic transformer, the input voltage can change roughly in one cycle of AC power frequency. A 1 μ F ceramic capacitor C4 connected from COMP pin to ground help to stabilize the control loop of the regulator.

Diode Selection

For maximum efficiency and performance, the rectifier (D5) should be fast low capacitance Schottky diodes with low reverse leakage at maximum operating voltage and temperature. With its low power dissipation, the Schottky diode outperforms other silicon diodes and increases overall efficiency.

Over Temperature Protection

An over temperature protection feature is to protect the AL8822 from excessive heat damage. When the junction temperature exceeds +160°C, the internal FET will be turned off. When junction temperature drops below +120°C, IC will turn on both FETs and return to normal operation.

Ordering Information

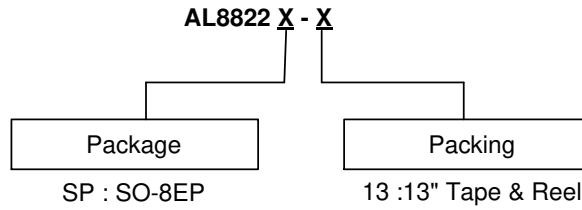

Part Number	Package Code	Package	13" Tape and Reel	
			Quantity	Part Number Suffix
AL8822SP-13	SP	SO-8EP	2500/Tape & Reel	-13

Marking Information

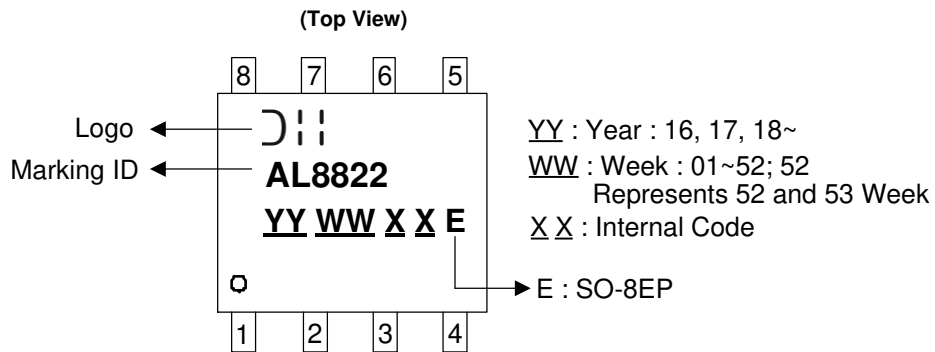

Package Outline Dimensions (All dimensions in mm (inch).)

(1) Package Type: SO-8EP

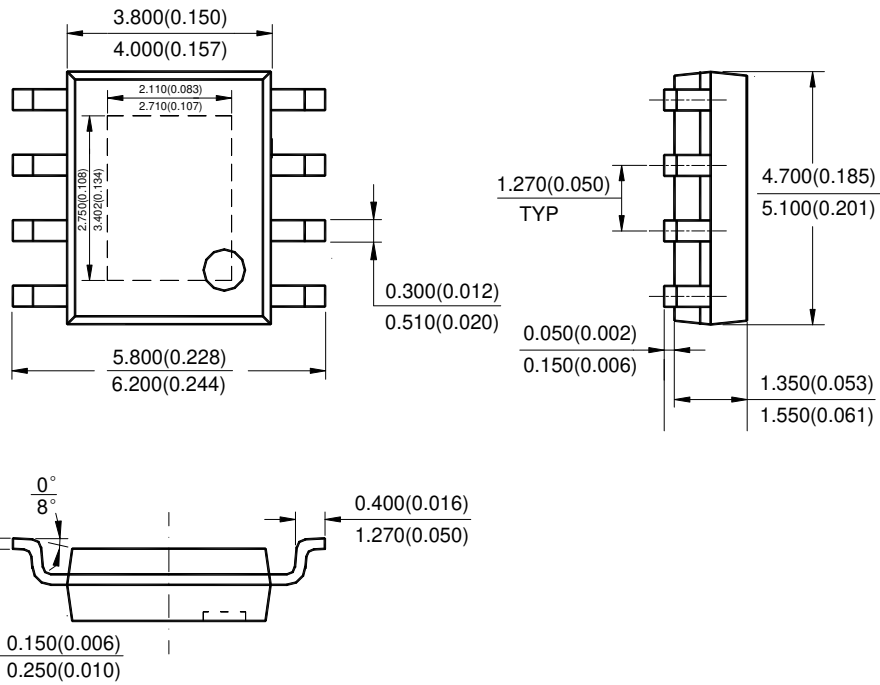

Note: Eject hole, oriented hole and mold mark is optional.

NEW PRODUCT

Suggested Pad Layout

(1)Package Type: SO-8EP

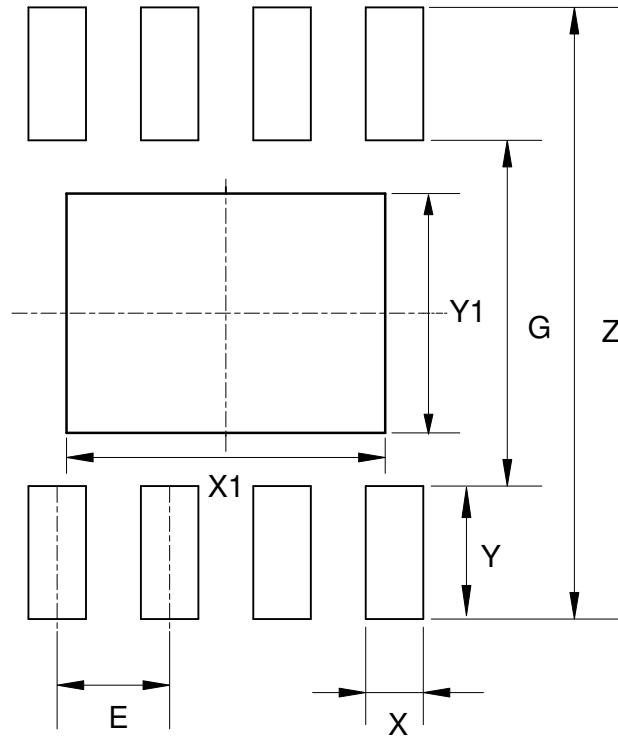

Dimensions	Z (mm)/(inch)	G (mm)/(inch)	X (mm)/(inch)	Y (mm)/(inch)	X1 (mm)/(inch)	Y1 (mm)/(inch)	E (mm)/(inch)
Value	6.900/0.272	3.900/0.154	0.650/0.026	1.500/0.059	3.600/0.142	2.700/0.106	1.270/0.050

NEW PRODUCT

IMPORTANT NOTICE

DIODES INCORPORATED MAKES NO WARRANTY OF ANY KIND, EXPRESS OR IMPLIED, WITH REGARDS TO THIS DOCUMENT, INCLUDING, BUT NOT LIMITED TO, THE IMPLIED WARRANTIES OF MERCHANTABILITY AND FITNESS FOR A PARTICULAR PURPOSE (AND THEIR EQUIVALENTS UNDER THE LAWS OF ANY JURISDICTION).

Diodes Incorporated and its subsidiaries reserve the right to make modifications, enhancements, improvements, corrections or other changes without further notice to this document and any product described herein. Diodes Incorporated does not assume any liability arising out of the application or use of this document or any product described herein; neither does Diodes Incorporated convey any license under its patent or trademark rights, nor the rights of others. Any Customer or user of this document or products described herein in such applications shall assume all risks of such use and will agree to hold Diodes Incorporated and all the companies whose products are represented on Diodes Incorporated website, harmless against all damages.

Diodes Incorporated does not warrant or accept any liability whatsoever in respect of any products purchased through unauthorized sales channel. Should Customers purchase or use Diodes Incorporated products for any unintended or unauthorized application, Customers shall indemnify and hold Diodes Incorporated and its representatives harmless against all claims, damages, expenses, and attorney fees arising out of, directly or indirectly, any claim of personal injury or death associated with such unintended or unauthorized application.

Products described herein may be covered by one or more United States, international or foreign patents pending. Product names and markings noted herein may also be covered by one or more United States, international or foreign trademarks.

This document is written in English but may be translated into multiple languages for reference. Only the English version of this document is the final and determinative format released by Diodes Incorporated.

LIFE SUPPORT

Diodes Incorporated products are specifically not authorized for use as critical components in life support devices or systems without the express written approval of the Chief Executive Officer of Diodes Incorporated. As used herein:

A. Life support devices or systems are devices or systems which:

1. are intended to implant into the body, or
2. support or sustain life and whose failure to perform when properly used in accordance with instructions for use provided in the labeling can be reasonably expected to result in significant injury to the user.

B. A critical component is any component in a life support device or system whose failure to perform can be reasonably expected to cause the failure of the life support device or to affect its safety or effectiveness.

Customers represent that they have all necessary expertise in the safety and regulatory ramifications of their life support devices or systems, and acknowledge and agree that they are solely responsible for all legal, regulatory and safety-related requirements concerning their products and any use of Diodes Incorporated products in such safety-critical, life support devices or systems, notwithstanding any devices- or systems-related information or support that may be provided by Diodes Incorporated. Further, Customers must fully indemnify Diodes Incorporated and its representatives against any damages arising out of the use of Diodes Incorporated products in such safety-critical, life support devices or systems.

Copyright © 2018, Diodes Incorporated

www.diodes.com