



Chipsmall Limited consists of a professional team with an average of over 10 year of expertise in the distribution of electronic components. Based in Hongkong, we have already established firm and mutual-benefit business relationships with customers from,Europe,America and south Asia,supplying obsolete and hard-to-find components to meet their specific needs.

With the principle of “Quality Parts,Customers Priority,Honest Operation,and Considerate Service”,our business mainly focus on the distribution of electronic components. Line cards we deal with include Microchip,ALPS,ROHM,Xilinx,Pulse,ON,Everlight and Freescale. Main products comprise IC,Modules,Potentiometer,IC Socket,Relay,Connector.Our parts cover such applications as commercial,industrial, and automotives areas.

We are looking forward to setting up business relationship with you and hope to provide you with the best service and solution. Let us make a better world for our industry!



Contact us

Tel: +86-755-8981 8866 Fax: +86-755-8427 6832

Email & Skype: info@chipsmall.com Web: www.chipsmall.com

Address: A1208, Overseas Decoration Building, #122 Zhenhua RD., Futian, Shenzhen, China



Jig Board Clamps

Other System Attachments

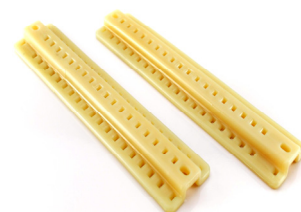
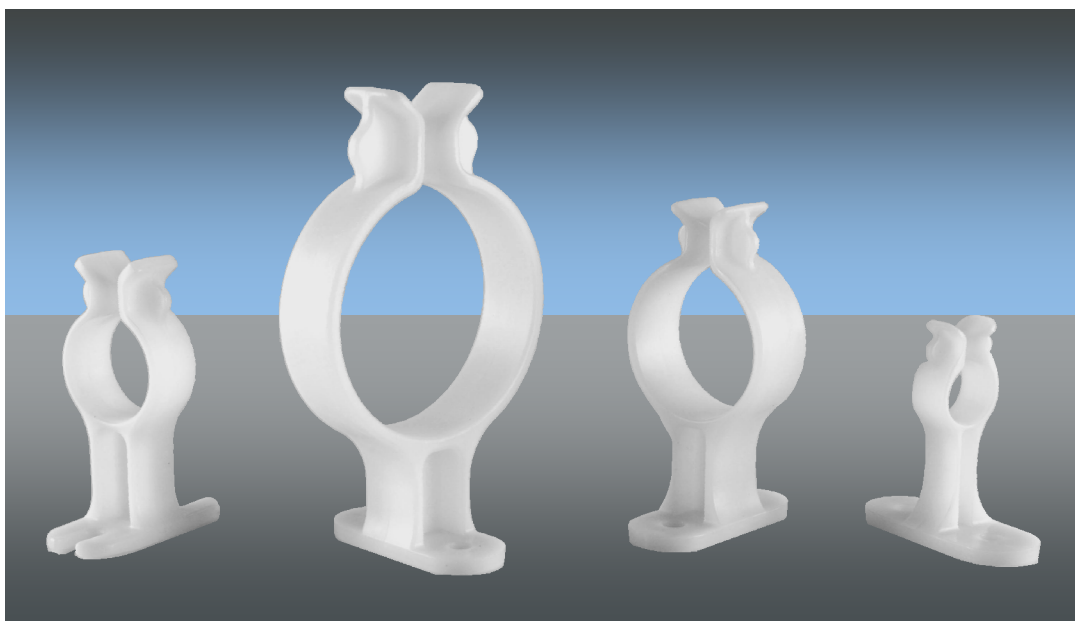

Raceways



Frame & Stringer
Clip-On Supports

Amphenol has over 30 years experience in System Attachment technology, serving the Aerospace, Military, Industrial and extreme environment markets. The company produces high quality, low cost products and prides itself on timely and accurate delivery.

Designed for pre-installation wire harness assembly, the Jig Board Clamps from Amphenol outlast and outperform other jig board clamping devices in the market. Made of Acetal, our durable clamps maintain their original shape after continued use, yet the smooth design of their edges diminish wear on the harnesses as they're being assembled. Developed in multiple sizes, our Jig Board Clamps can accommodate a wide range of cable diameters, while the one-piece design enables efficient inventory management. Amphenol's clamps make wire harness assembly simple and convenient – saving both time and money.

Features & Benefits:

- Strong and durable—lasts a long time
- Various sizes—accommodates a wide range of wire diameters
- Easy to use
- Smooth edges—limits wire chaffing/wear & tear
- One-Piece design
- No elastic band or straps required



Let us help you find the solution.

Technical Specifications

Other System Attachments

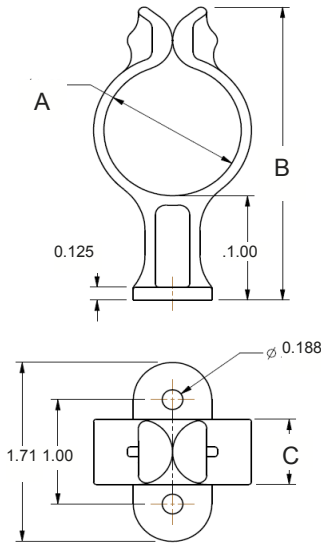

Amphenol Part Number	Ø A	B	C
ALBCLP-001-01	0.50"	1.85"	0.375"
ALBCLP-001-02	1.25"	2.81"	0.625"
ALBCLP-001-03	2.00"	3.80"	0.625"
ALBCLP-001-04	0.88"	2.36"	0.500"

Scale: Inches

Material: Acetal

Screw: 10/32



High Performance Clamps



Fairlead Blocks

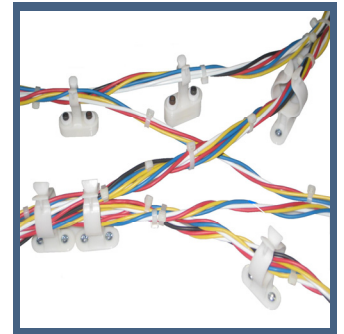

Contact information

Amphenol AirLB NA

3335 1ere Rue
St-Hubert, Qc. J3Y 8Y6 Canada
email: info@amphenol-airlb.com
Tel: 450-445-6007

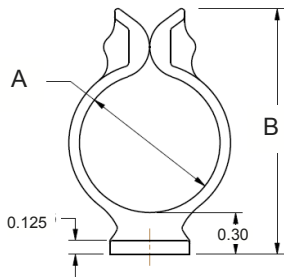

Amphenol Part Number	Ø A	B	C
ALBCLP-001-05	0.50"	1.85"	0.375"
ALBCLP-001-06	1.25"	2.81"	0.625"
ALBCLP-001-07	2.00"	3.80"	0.625"
ALBCLP-001-08	0.88"	2.36"	0.500"

Scale: Inches

Material: Acetal

Screw: 10/32

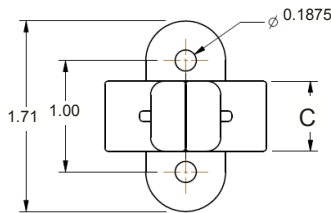

Jig Board Spacer

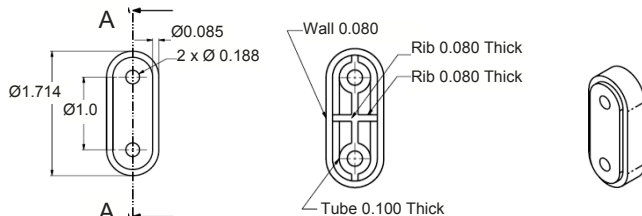

Scale: Inches

To aid in the installation of the wire harness assembly, the Jig Board Spacer effectively increases the height of the Jig Board Clamps—making wire routing more convenient.

Part Number: ALBSPC-001-01

Product Customization

Amphenol AirLB NA welcomes inquiries for application-specific modifications to our system attachments. Our products are continuously expanding to meet current and future customer needs.