



Chipsmall Limited consists of a professional team with an average of over 10 year of expertise in the distribution of electronic components. Based in Hongkong, we have already established firm and mutual-benefit business relationships with customers from,Europe,America and south Asia,supplying obsolete and hard-to-find components to meet their specific needs.

With the principle of "Quality Parts,Customers Priority,Honest Operation,and Considerate Service",our business mainly focus on the distribution of electronic components. Line cards we deal with include Microchip,ALPS,ROHM,Xilinx,Pulse,ON,Everlight and Freescale. Main products comprise IC,Modules,Potentiometer,IC Socket,Relay,Connector.Our parts cover such applications as commercial,industrial, and automotives areas.

We are looking forward to setting up business relationship with you and hope to provide you with the best service and solution. Let us make a better world for our industry!



Contact us

Tel: +86-755-8981 8866 Fax: +86-755-8427 6832

Email & Skype: info@chipsmall.com Web: www.chipsmall.com

Address: A1208, Overseas Decoration Building, #122 Zhenhua RD., Futian, Shenzhen, China



ALD15 Series

15 Amps

Data Sheet

Total Power: 35 Watts
Input Voltage: 48 V
of Outputs: Single

SPECIAL FEATURES

- High efficiency
- 40 °C to +75 °C ambient air operation
- 1.30" x 0.90" x 0.35" TH or SMT package
- High capacitive load limit on start-up
- Industry standard feature sets: UVLO, OVP, OCP, OTP, on/off enable, remote sense, output trim
- Basic insulation
- Regulation to zero load
- Fixed frequency switching
- EU Directive 2002/95/EC compliant for RoHS

SAFETY

- UL, cUL: 60950-1
- TUV: EN60950-1

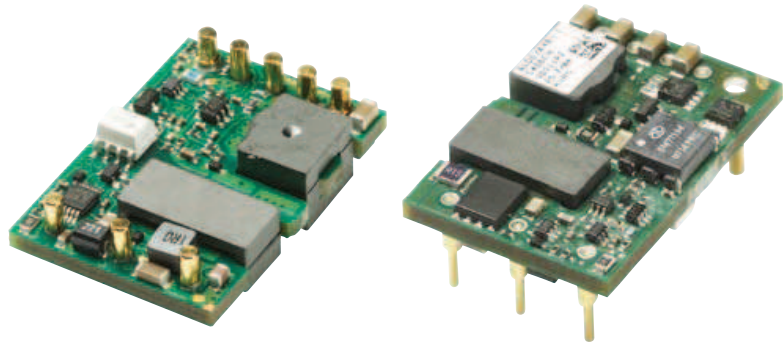

Electrical Specifications

Input	
Input range	36 to 76 Vdc
Input surge	100 V / 100 ms
Efficiency	90.5% @ 12 V
Output	
Line regulation	±0.1% Vo (typical)
Load regulation	±0.1% Vo (typical)
Noise/ripple ¹	40 mVp-p (typical)
Remote sense	Up to 10% of Vo
Transient response	3% Vo (typical deviation) 50% to 75% load change 80 µs setting time (typical)
Ovoltage protection	125% Vo typical (autorecovery)
Overcurrent protection	115% Io typical (autorecovery)
Overtemperature protection	115 °C average PCB temperature (autorecovery)
Switching frequency	Fixed frequency
Isolation voltage	1500 Vdc minimum (2000 Vdc ALD10F48N)
Control	
Voltage adjust	90 - 100% Vo
Enable	TTL compatible

Environmental Specifications

Operating ambient temperature range	-40 °C to +85 °C
Storage temperature	-40 °C to +125 °C
MTBF	1 million hours

Ordering Information

Model Number	Input Voltage	Output Voltage	Output Current	Efficiency ²
ALD03B48(N)-(L)/(6L)/(SL)	36 - 75 V	12 V	2.75 A	90.5%
ALD07A48(N)-(L)/(6L)/(SL)	36 - 75 V	5.0 V	7.00 A	91%
ALD10F48(N)-(L)/(6L)/(SL)	36 - 75 V	3.3 V	10.00 A	90%
ALD11G48(N)-(L)/(6L)/(SL)	36 - 75 V	2.5 V	11.00 A	89%
ALD13Y48(N)-(L)/(6L)/(SL)	36 - 75 V	1.8 V	13.00 A	87%
ALD15M48(N)-(L)/(6L)/(SL)	36 - 75 V	1.5 V	15.00 A	85%
ALD15K48(N)-(L)/(6L)/(SL)	36 - 75 V	1.2 V	15.00 A	84%

Notes:

Efficiency values taken at nominal input full load condition, 25 °C ambient temperature.

Options:

"N" = Designates Negative Logic Enable (default is Positive Enable with no suffix "N" required)

"L" = RoHS compliant

"-6L" = 3.7 mm nominal pin length (default is 5 mm nominal pin length with no suffix "-6" required), RoHS compliant

"-SL" = Surface Mount Termination (default is thru hole termination with no suffix "-S" required) RoHS compliant. STRL designates Taped and Reeled option for SMT.

Mechanical Drawings

Through-hole Termination

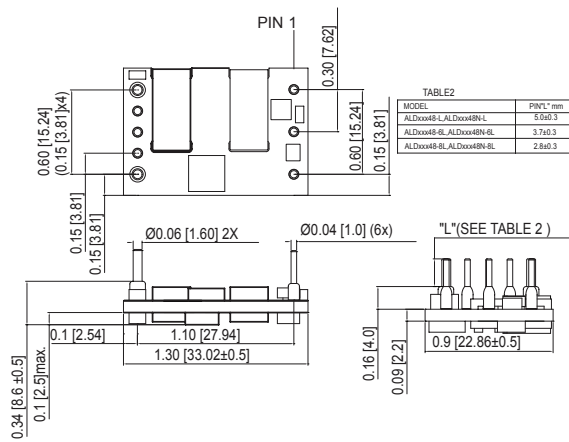

Surface-mount Termination

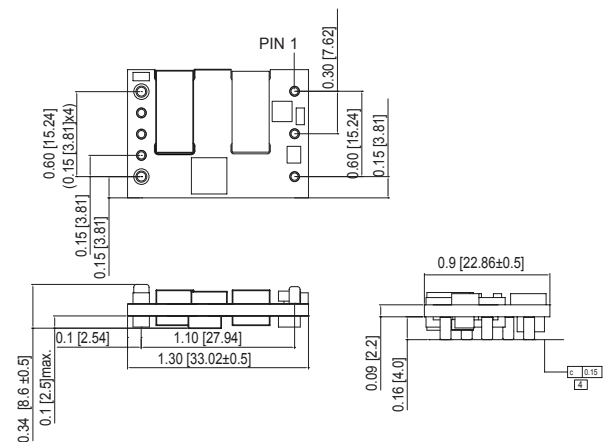

Pin Assignments

Single Output	
Pin 1	+Vin
Pin 2	Enable
Pin 3	-Vin
Pin 4	-Vout
Pin 5	-Sense
Pin 6	Trim
Pin 7	+Sense
Pin 8	+Vout

Mechanical Drawings

Recommended PAD/Hole Pattern

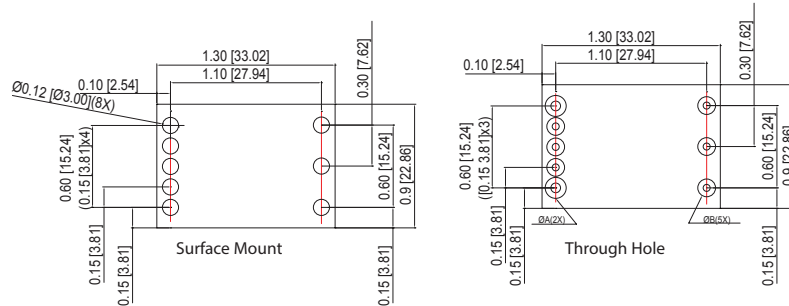
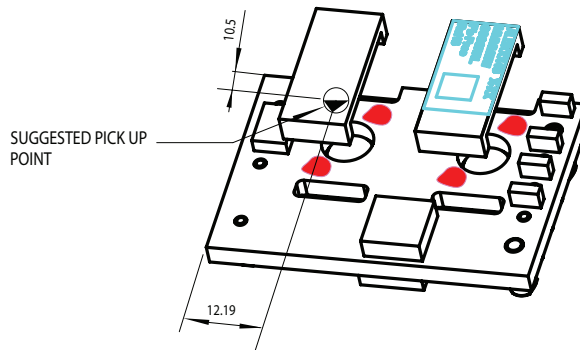

TABLE1

HOLE & PAD DIAMETER FOR CUSTOMER (RECOMMENDED)		
	HOLE DIAMETER (Ød)	PAD DIAMETER (ØD)
ØA	Ø1.9	Ø2.9
ØB	Ø1.3	Ø2.3

Recommended Pick-up Point



Notes:

- 20 MHz bandwidth. External 10 µF tantalum capacitor in parallel with 0.1 µF ceramic capacitor placed across +Vout and -Vout; 33 µF e-cap or equivalent placed across +Vin and -Vin.
- Efficiency measurements taken at full load, nominal line and TA = 25 °C
- All specifications are typical at nominal line, full load and TA = 25 °C unless otherwise noted.
- Mechanical drawings are for reference only. Dimensions are in inches [mm]. Mechanical tolerance ± 0.020 [± 0.50]
- Technical Reference Notes should be consulted for detailed information when available.
- All specifications subject to change without notice.
- Warranty two (2) years.
- The through-hole terminated modules are intended for wave soldering process.

WORLDWIDE OFFICES

Americas

2900 S.Diablo Way
Tempe, AZ 85282
USA
+1 888 412 7832

Europe (UK)

Waterfront Business Park
Merry Hill, Dudley
West Midlands, DY5 1LX
United Kingdom
+44 (0) 1384 842 211

Asia (HK)

14/F, Lu Plaza
2 Wing Yip Street
Kwun Tong, Kowloon
Hong Kong
+852 2176 3333

ARTESYN[™]
EMBEDDED TECHNOLOGIES

www.artesyn.com

Artesyn Embedded Technologies, Artesyn and the Artesyn Embedded Technologies logo are trademarks and service marks of Artesyn Embedded Technologies, Inc. All other names and logos referred to are trade names, trademarks, or registered trademarks of their respective owners. © 2015 Artesyn Embedded Technologies, Inc. All rights reserved. For full legal terms and conditions, please visit www.artesyn.com/legal.

For more information: www.artesyn.com/power
For support: productsupport.ep@artesyn.com