



Chipsmall Limited consists of a professional team with an average of over 10 year of expertise in the distribution of electronic components. Based in Hongkong, we have already established firm and mutual-benefit business relationships with customers from,Europe,America and south Asia,supplying obsolete and hard-to-find components to meet their specific needs.

With the principle of "Quality Parts,Customers Priority,Honest Operation,and Considerate Service",our business mainly focus on the distribution of electronic components. Line cards we deal with include Microchip,ALPS,ROHM,Xilinx,Pulse,ON,Everlight and Freescale. Main products comprise IC,Modules,Potentiometer,IC Socket,Relay,Connector.Our parts cover such applications as commercial,industrial, and automotives areas.

We are looking forward to setting up business relationship with you and hope to provide you with the best service and solution. Let us make a better world for our industry!



Contact us

Tel: +86-755-8981 8866 Fax: +86-755-8427 6832

Email & Skype: info@chipsmall.com Web: www.chipsmall.com

Address: A1208, Overseas Decoration Building, #122 Zhenhua RD., Futian, Shenzhen, China



ALT SERIES

8-pin Plug-in Alternating Relay



Wiring Diagram

TYPICAL WIRING DIAGRAM FOR THE ALT-S

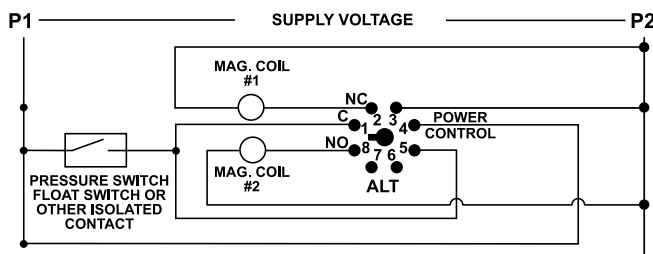

TYPICAL WIRING DIAGRAM FOR THE ALT-X (CROSS CONNECTED)

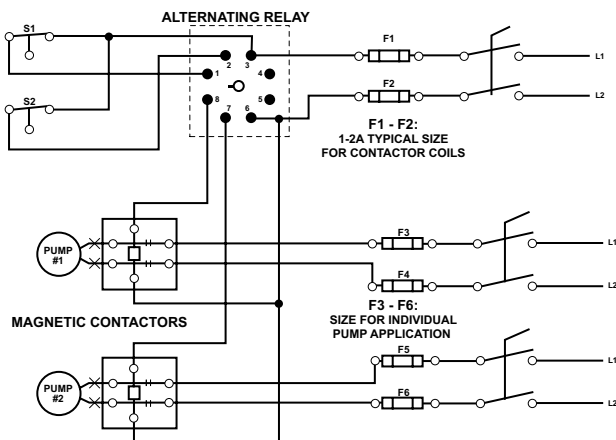

Accessories



OT08PC Octal 8-pin Socket
8-pin 35mm DIN rail or surface mount. Rated at 10A @ 600VAC. Surface mounted with two #6 screws or snaps onto a 35 mm DIN rail.

Description

The ALT alternating relays are used to alternate between two loads. The ALT is commonly used in duplex pumping applications to balance the runtime of both pumps.

The **ALT-S** is used in single high-level float applications. When the float switch opens, the alternating relay changes state, forcing the other pump to run the next time the float closes. All ALT relays have a built-in debounce feature that prevents the relay from changing state if the switch or float contact bounces momentarily.

The **ALT-X** has an internal cross-connected relay and is used in dual high-level float applications. These floats are commonly referred to as lead and lag floats.

The pumps alternate as in the ALT-S version but the cross-connected relay configuration allows both pumps to run simultaneously when both the lead and lag floats are closed.

These relays are also available with a built-in switch (SW option) that is used to manually force one of the pumps to run every time the float switch is closed. This is helpful when a pump has been removed for repair or for test purposes. In the case of the **ALT-X-SW**, the switch essentially forces one pump to be the lead pump, while still allowing the second to run when both floats are closed.

Must use the OT08PC socket for UL Rating!

*Note: Manufacturer's recommended screw terminal torque for the RB Series and OT Series Octal Sockets is 12 in.-lbs.

Features & Benefits

FEATURES	BENEFITS
Debounce time delay	Prevents nuisance actuating causes by waves or spashing in the tank
Built-in manual/auto switch	Force lead pump operation when a pump is removed for repair or testing (on select models)

Ordering Information

MODEL	LINE VOLTAGE	DESCRIPTION
ALT024-S	20-26VAC or VDC	For single high-level float applications
ALT024-S-SW	20-26VAC or VDC	For single high-level float applications with built in manual switch
ALT115-S	95-125VAC	For single high-level float applications
ALT115-S-SW	95-125VAC	For single high-level float applications with built in manual switch
ALT115-X	95-125VAC	For dual high-level (lead and lag) float applications
ALT115-X-SW	95-125VAC	For dual high-level (lead and lag) float applications with built in manual switch
ALT230-S	195-250VAC	For single high-level float applications
ALT230-S-SW	195-250VAC	For single high-level float applications with built in manual switch
ALT230-X	195-250VAC	For dual high-level (lead and lag) float applications
ALT230-X-SW	195-250VAC	For dual high-level (lead and lag) float applications with built in manual switch

ALT SERIES

Specifications

Input Characteristics	
Supply Current	40mA
Functional Characteristics	
Debounce Time Delay	0.5 second
Control Input Impedance (min)	
24	10k Ω
115	56k Ω
230	100k Ω
Output Characteristics	
Output Contact Rating	480VA @ 240VAC

General Characteristics

Temperature Range	-40° to 50°C (-40° to 122°F)
Maximum Input Power	5 W
Safety Marks	
UL (OT08PC octal socket required)	UL508 (File #E68520)
CSA	C22.2 No. 14 (File #46510)
Dimensions (with socket)	H 44.45 mm (1.75"); W 60.33 mm (2.375"); D 104.78 mm (4.125")
Weight	0.38 lb. (6.08 oz., 172.67 g)
Mounting Method	DIN rail or surface mount (plug into OT08PC socket)
Socket Available	OT08PC (UL Rating 600V)

The 600V socket can be surface mounted or installed on DIN Rail.