



Chipsmall Limited consists of a professional team with an average of over 10 year of expertise in the distribution of electronic components. Based in Hongkong, we have already established firm and mutual-benefit business relationships with customers from,Europe,America and south Asia,supplying obsolete and hard-to-find components to meet their specific needs.

With the principle of “Quality Parts,Customers Priority,Honest Operation,and Considerate Service”,our business mainly focus on the distribution of electronic components. Line cards we deal with include Microchip,ALPS,ROHM,Xilinx,Pulse,ON,Everlight and Freescale. Main products comprise IC,Modules,Potentiometer,IC Socket,Relay,Connector.Our parts cover such applications as commercial,industrial, and automotives areas.

We are looking forward to setting up business relationship with you and hope to provide you with the best service and solution. Let us make a better world for our industry!



Contact us

Tel: +86-755-8981 8866 Fax: +86-755-8427 6832

Email & Skype: info@chipsmall.com Web: www.chipsmall.com

Address: A1208, Overseas Decoration Building, #122 Zhenhua RD., Futian, Shenzhen, China



Description

The AM9468 is a high performance ultra low noise single phase (single-coil) brushless direct current (BLDC) fan and motor driver. The integrated full-bridge driver output stage uses a BTL linear driver architecture to minimize audible switching noise and electromagnetic interference (EMI) providing a low noise solution.

For system flexibility the motor speed can be controlled by either an external PWM signal or by a DC voltage or from a thermistor network. Based on the input signal, the AM9468 adjusts the output duty cycle.

To help protect the motor coil, the AM9468 provides Rotor Lock Protection which shuts down the output drive if rotor lock is detected. The device automatically re-starts when the rotor lock is removed. In case of over voltage, the device shuts down the output drive and enters standby mode to help prevent over voltage stress on the coil. Over temperature shutdown provides thermal protection for the device.

A Tachometer output is provided by open-drain Frequency Generator (FG) Pin which allows external interface to monitor motor rotation or speed. The FG output is the magnetic change frequency. Additionally, a rotor lock detect output is provided by open-drain RD pin.

The AM9468 is available in power capable low profile TSSOP-16 package.

Features

- Single-Phase Full Wave BLDC Fan/Motor Drive with BTL Output (BTL Amplifier Gain = 49dB)
- Low Noise Architecture
- Wide Operating Voltage Range: 2.4V to 18V
- PWM Speed Control with External PWM Input
- DC Voltage Speed Control by Adjusting VCONT and RMI Voltage
- Hall Bias Output: $V_{HB} = 1.25V$
- Built-in Quick Start Circuit
- Lock Protection with Automatic Restart
- Frequency Generator (FG) Output
- Rotor Lock Detection (RD) Output
- Current Limit Circuit
- R_F Defines The Current Limit;
 $R_F = 1\Omega$ will Achieve 250mA Current Limit
- Thermal Shut-Down (TSD) Circuit
- **Lead-Free Finish; RoHS Compliant (Notes 1 & 2)**
- **Halogen and Antimony Free. "Green" Device (Note 3)**

Notes: 1. EU Directive 2002/95/EC (RoHS) & 2011/65/EU (RoHS 2) compliant. All applicable RoHS exemptions applied.
2. See http://www.diodes.com/quality/lead_free.html for more information about Diodes Incorporated's definitions of Halogen- and Antimony-free, "Green" and Lead-free.
3. Halogen- and Antimony-free "Green" products are defined as those which contain <900ppm bromine, <900ppm chlorine (<1500ppm total Br + Cl) and <1000ppm antimony compounds

Pin Assignments

(Top View)

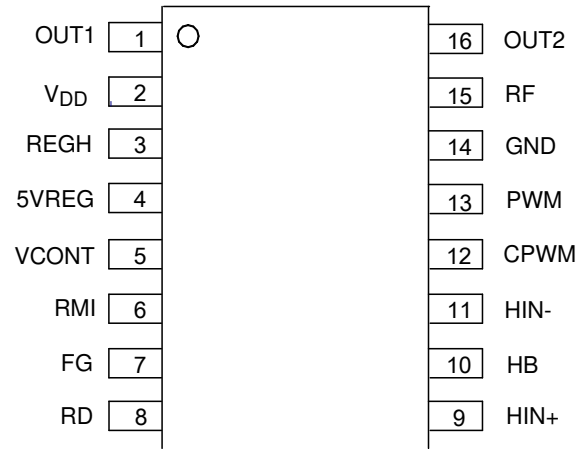

TSSOP-16

Applications

- 9V/ 12V / 15V BLDC Cooling Fans and Motors
- CPU Cooling Fans for Notebooks and Desktop BLDC Fans
- Instruments Cooling Fans
- Medium Voltage/ Low Power BLDC Motors

Typical Applications Circuit (Notes 4 and 5)

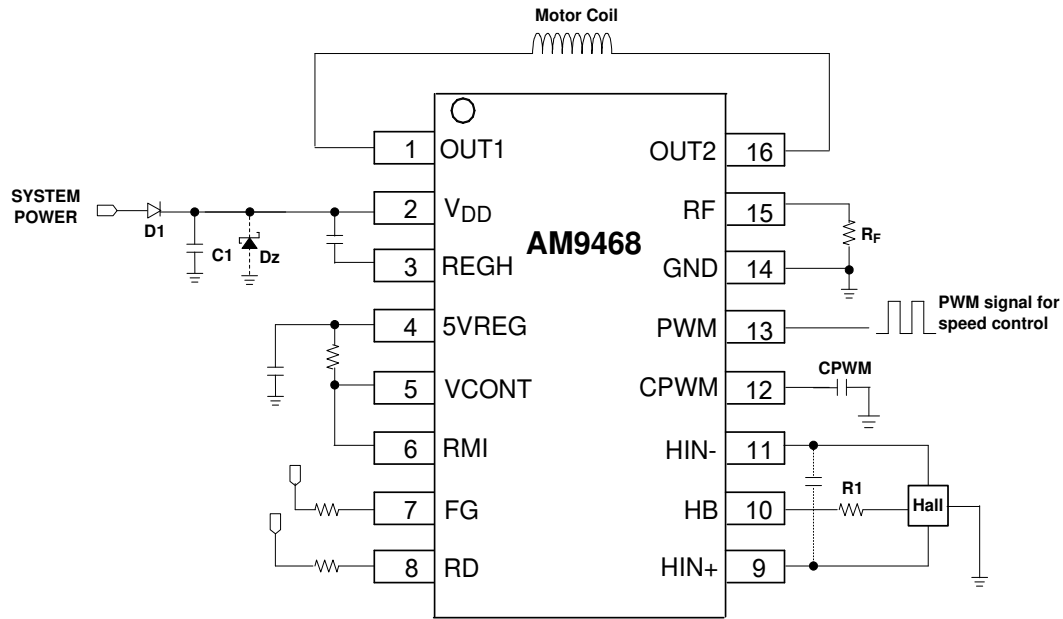

Typical Applications Circuit for PWM Speed Control

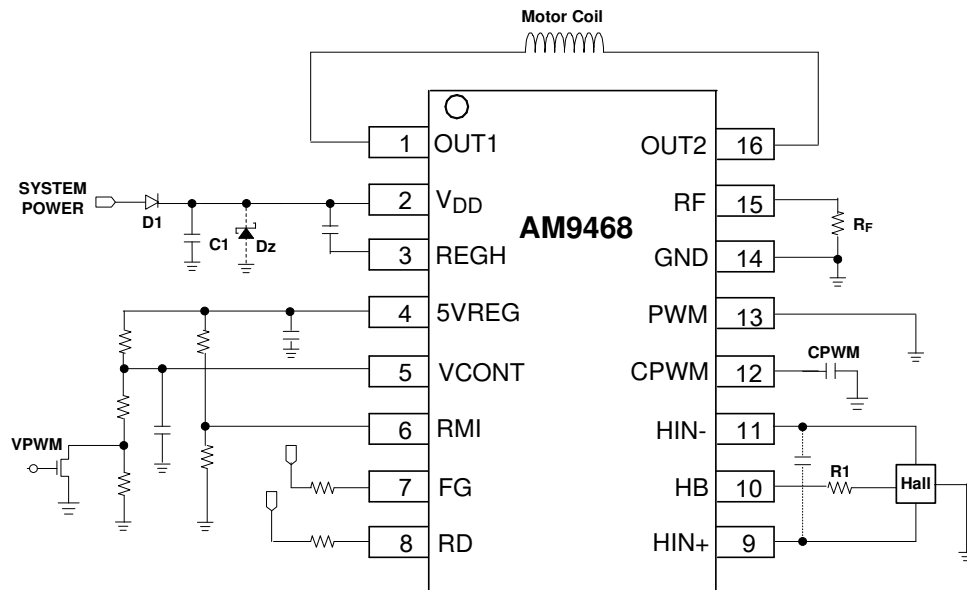

Typical Applications Circuit for VCONT/RMI Control

- Notes:
- C1 is for power stabilization and to strengthen the noise immunity and should be as close to the V_{DD} pin as possible. The recommended value for C1 is 1μF typically. The value of capacitor can be optimized depending on the operating mode, motor voltage and the motor current. For PWM speed control mode, with datasheet current capability, the recommended capacitor value is 1μF. The value of the C1 should be checked in the motor design and route in its operating conditions if it is reduced or increased from the recommended value of 1μF.
 - Diode D1 is for the reverse connection protection. In addition to power stabilization and noise immunity, C1 also absorbs regenerative motor spikes. Depending on the amount of regenerative voltage spike, value of C1 needs to be adjusted. The zener diode Dz is used to clamp the regenerative voltage spike from the motor operation to safe level when reverse blocking diode D1 is used. If reverse blocking diodes is not used, the use of zener clamp Dz depends on the supply voltage capability to effectively sink the regenerative energy and voltage spike. The value of C1 and the requirement Dz needs to be verified on each application design.

Pin Descriptions

Pin Number	Pin Name	Description
1	OUT1	Output drive - source & sink capable pin
2	V _{DD}	Power supply input pin
3	REGH	High side regulator output voltage
4	5VREG	5V regulator output voltage
5	VCONT	Output duty control pin in DC signal speed control mode; Voltage in VCONT is compared with triangular wave on CPWM for the output duty ratio.
6	RMI	Output minimum duty (minimum speed) control pin for CPWM
7	FG	Frequency Generator (FG) - The FG output is same as the magnetic change frequency
8	RG	Rotor lock detect open drain output
9	HIN+	Hall device positive input pin
10	HB	Hall bias voltage
11	HIN-	Hall device negative input pin
12	CPWM	Capacitor connection pin for PWM oscillator and main clock
13	PWM	PWM signal input pin for PWM speed control mode. The PWM on this pin controls the output duty directly.
14	GND	Ground pin
15	RF	Current limit set pin; Connect a resistor between RF pin and GND, current limit is defined by $250\text{mV}/R_F$
16	OUT2	Output drive - source & sink capable pin

NEW PRODUCT

Functional Block Diagram

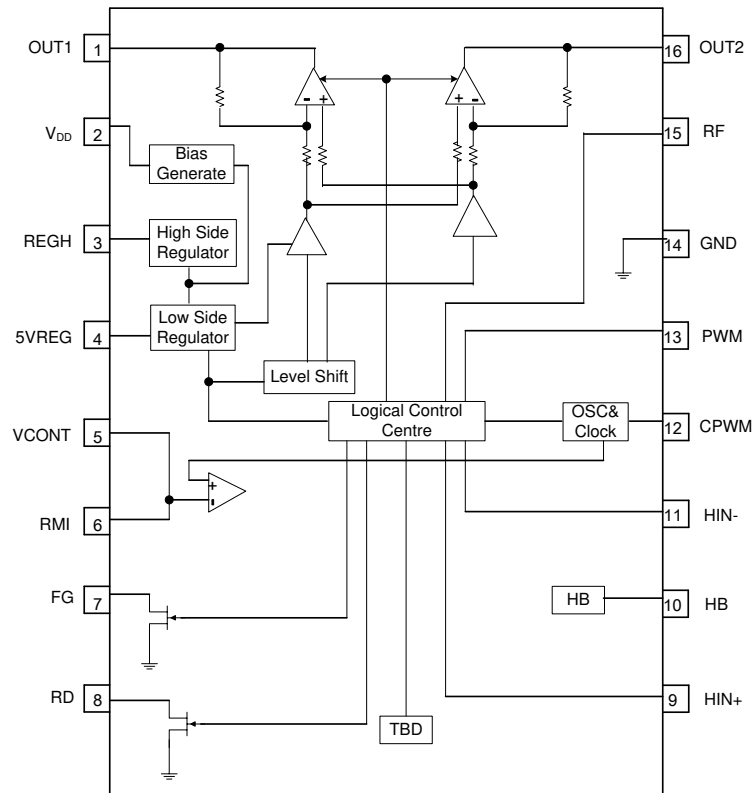

Absolute Maximum Ratings (Note 6) @ $T_A = +25^{\circ}\text{C}$, unless otherwise specified.

Symbol	Characteristics		Rating	Unit
V_{DD_MAX}	Maximum Supply Voltage (Note 7)		24	V
$V_{REVERSE}$	Reverse Supply Voltage on All Pins		-0.3	V
V_{PWM_MAX}	Maximum Voltage on Logic PWM Pin		7	V
$I_{OUT(PEAK)}$	Maximum Output Current (Peak)		1,200	mA
$I_{OUT(CONT)}$	Maximum Continuous Current		500	mA
I_{RD}	Maximum RD Output Current		5	mA
V_{RD}	Maximum RD Voltage		24	V
I_{FG}	Maximum FG Output Current		5	mA
V_{FG}	Maximum FG Voltage		24	V
I_{HB}	Maximum HB Output Current		10	mA
P_D	Power Dissipation (Notes 8 & 9)	TSSOP-16	1,610	mW
T_{STG}	Storage Temperature Range		-65 to +150	$^{\circ}\text{C}$
T_J	Maximum Junction Temperature		+150	$^{\circ}\text{C}$
ESD HBM	Human Body Model ESD Capability		4	kV

- Notes:
- Stresses greater than the 'Absolute Maximum Ratings' specified above may cause permanent damage to the device. These are stress ratings only; functional operation of the device at these or any other conditions exceeding those indicated in this specification is not implied. Device reliability may be affected by exposure to absolute maximum rating conditions for extended periods of time.
 - The absolute maximum V_{DD} of 24V is a transient stress rating and is not meant as a functional operating condition. It is not recommended to operate the device at the absolute maximum rated conditions for any period of time.
 - For thermal de-rating curves under different PCB sizes and layout conditions, see thermal performance section.
 - AM9468 exposed pad soldered to minimum recommended landing pads (see Package Outline Dimension section) on 3inch x 4.5inch four-layer 2oz.copper glass epoxy PCB (1.6mm thickness), calculated in accordance with JESD 51-7. See thermal performance section.

Recommended Operating Conditions

Symbol	Characteristic	Conditions	Min	Max	Unit
V_{DD}	Supply Voltage When The Device Is Operating Normally With All Circuits Active	Operating; All circuits active	2.4	18	V
V_{ICM}	Hall Input Common-Mode Input Voltage Range	-	0.3	$V_{5VREG} - 1.5V$	V
V_{CONTIN}	VCONT Input Voltage Range	-	0.3	V_{5VREG}	V
V_{RMIN}	RMI Input Voltage Range	-	0.3	V_{5VREG}	V
T_A	Operating Temperature Range	Operating	-40	+105	$^{\circ}\text{C}$

Electrical Characteristics (Note 10) (@ $T_A = +25^{\circ}\text{C}$, $V_{DD} = 12V$, unless otherwise specified.)

Symbol	Characteristics	Conditions	Min	Typ	Max	Unit
I_{DD}	Supply Current	-	-	2.5	4.0	mA
V_{OV_TH}	Over Voltage Protection Threshold for Shutdown to Standby Mode	Voltage increasing	19.5	20.5	21.5	V
V_{OV_RLTH}	Over Voltage Release Threshold	Voltage decreasing	18.3	19.5	20.5	V

- Note: 10. Typical data is measured at $T_A = +25^{\circ}\text{C}$, $V_{DD} = 12V$. The maximum and minimum parameters values over operating temperature range are not tested in production, they are guaranteed by design, characterization and process control.

Electrical Characteristics (Note 11) (@ $T_A = +25^\circ\text{C}$, $V_{DD} = 12\text{V}$, unless otherwise specified.) (Cont.)

Symbol	Characteristics	Conditions	Min	Typ	Max	Unit
V_O	Output On Voltage, Source + Sink	$I_{OUT} = 500\text{mA}$ (Source+Sink) $T_A = -40^\circ\text{C}$ to $+105^\circ\text{C}$	–	0.45	0.68	V
V_{RF}	Current Limit Voltage	$T_A = -40^\circ\text{C}$ to $+105^\circ\text{C}$	230	250	270	mV
V_{RGL}	5VREG Output Voltage	$I_{SVREG} = 5\text{mA}$, $T_A = -40^\circ\text{C}$ to $+105^\circ\text{C}$	4.8	5	5.2	V
V_{RGH}	REGH Output Voltage	$I_{REGH} = 5\text{mA}$	$V_{DD} - 4.6$	$V_{DD} - 4.2$	$V_{DD} - 3.9$	V
V_{HB}	Hall Bias Output Voltage	$I_{HB} = 5\text{mA}$, $T_A = -40^\circ\text{C}$ to $+105^\circ\text{C}$	1.20	1.25	1.30	V
I_{HIN}	Hall Input Bias Current	–	–	–	0.5	μA
V_{INOF5}	Hall Amplifier Output Offset Voltage	–	-5	–	5	mV
G_H	Hall Amplifier Voltage Gain	–	48	52	–	dB
V_{PWML}	PWM Pin Input Low	–	0	–	1.2	V
V_{PWHH}	PWM Pin Input High	–	1.8	–	5VREG	V
I_{PWM}	PWM Pin Bias Current	PWM=GND	-17	-10	-6	μA
t_{PWM_MIN}	Input PWM Smallest Width	–	2	–	–	μs
f_{PWM_RANGE}	External Input PWM Frequency Range	–	8	–	100	kHz
I_{CPC}	CPWM Charge Current	$T_A = -40^\circ\text{C}$ to $+105^\circ\text{C}$	16.4	–	19.6	μA
I_{CPD}	CPWM Discharge Current	$T_A = -40^\circ\text{C}$ to $+105^\circ\text{C}$	16.4	–	19.6	μA
R_{CP}	CPWM Charge/Discharge Current Ratio	$R_{CP} = I_{CPC} / I_{CPD}$	0.9	1	1.11	–
V_{CPH}	CPWM Oscillation High Level	$T_A = -40^\circ\text{C}$ to $+105^\circ\text{C}$	3.35	3.5	3.65	V
V_{CPL}	CPWM Oscillation Low Level	$T_A = -40^\circ\text{C}$ to $+105^\circ\text{C}$	0.95	1.0	1.05	V
V_{CPA}	CPWM Oscillation Amplitude	$T_A = -40^\circ\text{C}$ to $+105^\circ\text{C}$	2.3	2.5	2.7	V
f_{CPWM}	CPWM Oscillation frequency	CPWM = 100pF	–	36	–	kHz
I_{CONT}	VCONT Pin Input Bias Current	–	–	–	0.3	μA
I_{RMI}	RMI Pin Input Bias Current	–	–	–	0.3	μA
V_{RD}	RD Output Low Voltage	$I_{RD} = 3\text{mA}$	–	–	0.3	V
I_{RDL}	RD Output Leakage Current	$V_{RD} = 18\text{V}$	–	–	1	μA
V_{FG}	FG Output Low Voltage	$I_{FG} = 3\text{mA}$	–	–	0.3	V
I_{FGL}	FG Output Leakage Current	$V_{FG} = 18\text{V}$	–	–	1	μA
ΔV_{FG}	FG Comparator Hysteresis	–	–	± 5	–	mV
$t_{LCK_DET_ON}$	Output ON Time in Lock Detection	$C_{PWM} = 100\text{pF}$	–	0.5	–	s
t_{OFF}	Output OFF Time in Lock Mode	$C_{PWM} = 100\text{pF}$	–	4.5	–	s
R_T	Output OFF/ON Ratio in Lock Detection	$C_{PWM} = 100\text{pF}$, $R_T = t_{ACT} / t_{DET}$	–	9	–	s
$T_{J_SDN_TH}$	IC Junction Temperature Thermal Shutdown Threshold	–	–	+175	–	$^\circ\text{C}$
$T_{J_SDN_HYST}$	IC Junction Temperature Thermal Shutdown Hysteresis	–	–	+25	–	$^\circ\text{C}$

Note: 11. Typical data is measured at $T_A = +25^\circ\text{C}$, $V_{DD} = 12\text{V}$. The maximum and minimum parameters values over operating temperature range are not tested in production, they are guaranteed by design, characterization and process control.

Operating Characteristics

Standby and Start-up Timing

When PWM pin input signal is logic "L" level continuously for time longer than t_{SLP} , the device enters standby mode as shown below. When PWM pin signal is "H" level, the device turns active and operates normally. The PWM pin is also used to control the motor speed with external PWM signal into this pin. The lowest frequency PWM signal is defined by t_{SLP} , i.e. the PWM duty low time has to be smaller t_{SLP} for motor speed control.

$t_{SLP} = 400\mu s$ typical

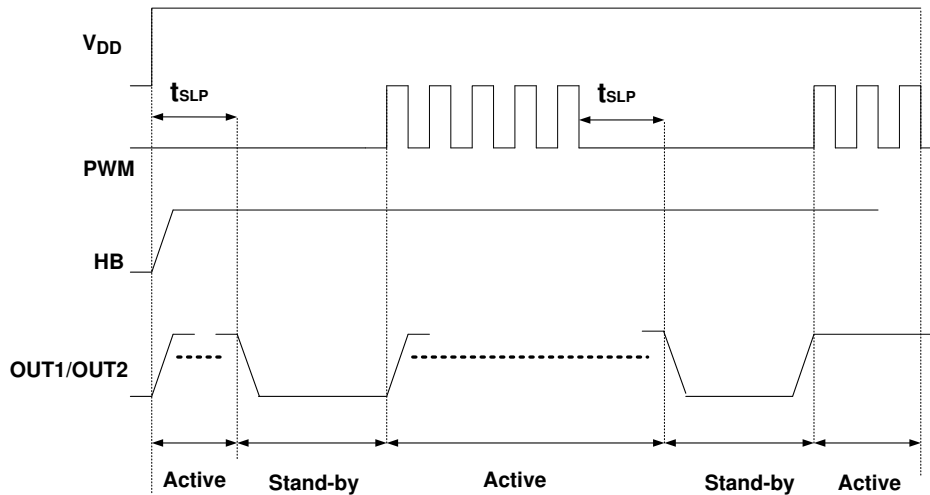

In Normal Operation/Rotation

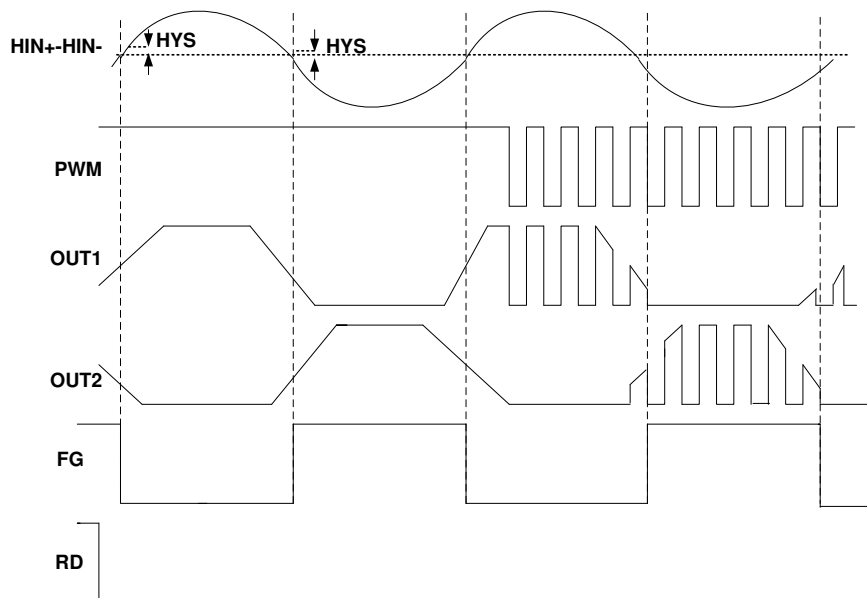

Truth Table for Various Modes with PWM pin

HIN+	HIN-	PWM	OUT1	OUT2	FG	MODE
H	L	H	H	L	L	Drive
		L	L	L		Regenerate
L	H	H	L	H	OFF	Drive
		L	L	L		Regenerate

Operating Characteristics (Cont.)

VCONT/RMI Control

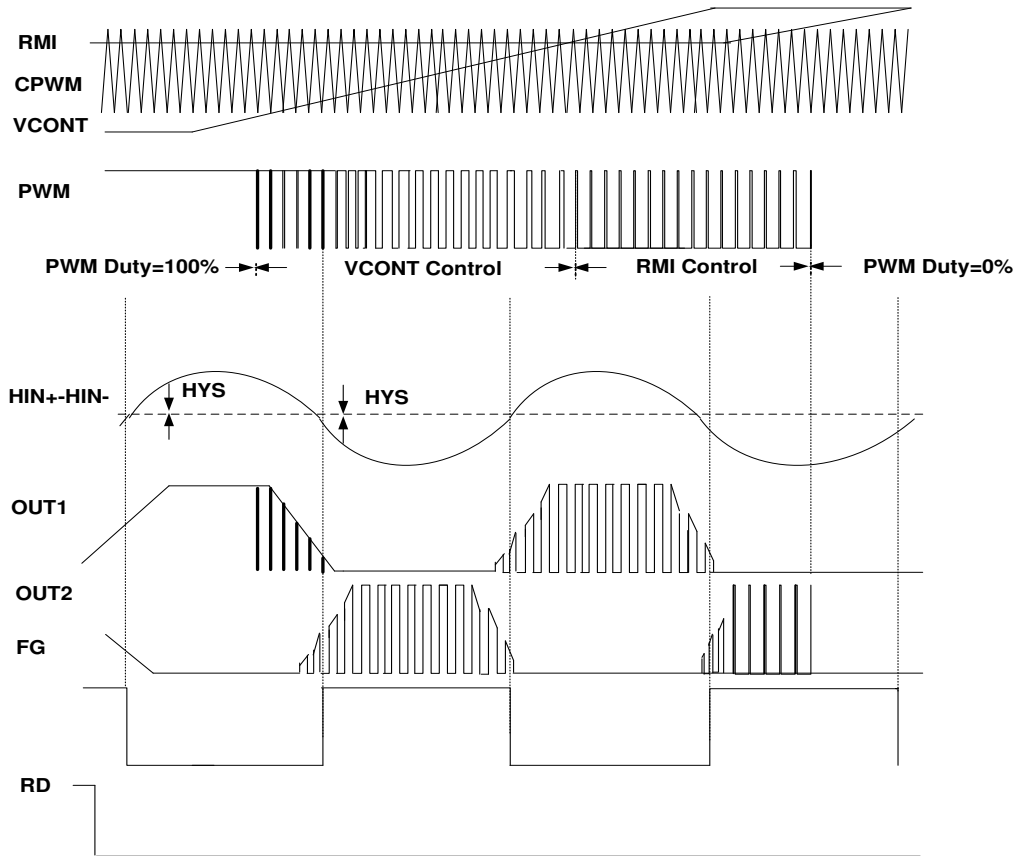

Truth Table for Various Modes with VCONT/RMI PIN

HIN+	HIN-	PWM2 (Note 12)	OUT1	OUT2	FG	MODE
H	L	H	H	L	L	Drive
		L	L	L		Regenerate
L	H	H	L	H	OFF	Drive
		L	L	L		Regenerate

Note: 12. PWM2 is internal signal.

Operating Characteristics (Cont.)

Motor Lock

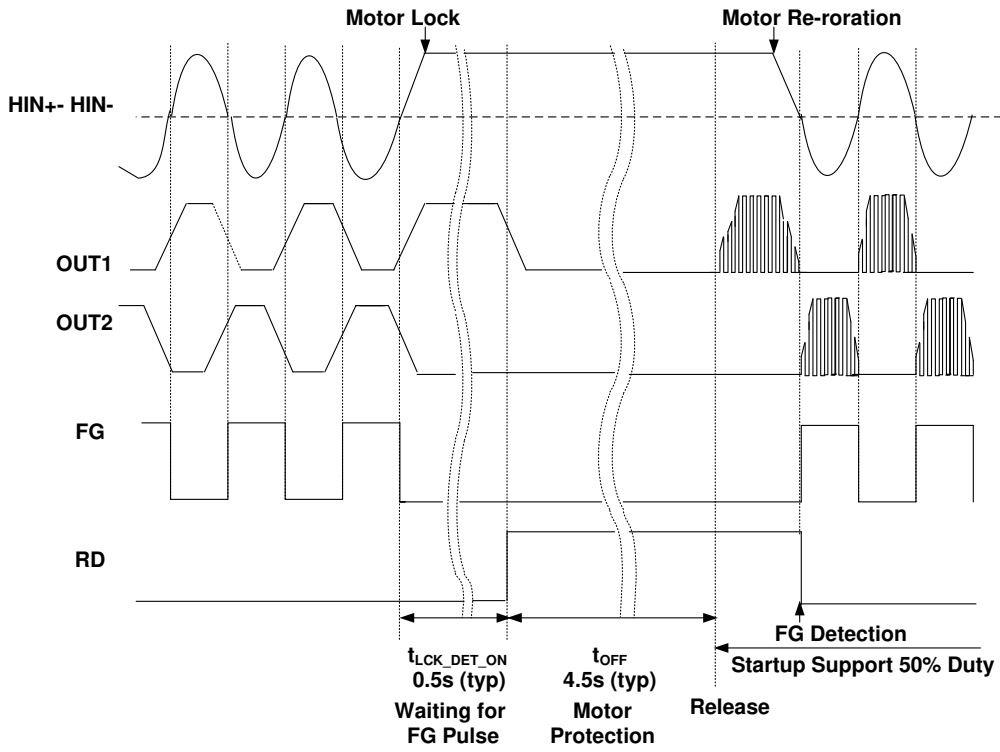

NEW PRODUCT

Application Note

HIN-Bias – Hall Bias Output

This is a 1.25V nominal voltage source to bias a differential un-buffered Hall element sensor. If a Hall element requires a lower voltage than the HIN-Bias output, connect an appropriate value resistor between the HIN-Bias pin and the Hall element supply pin.

HIN+ and HIN- – Hall Inputs

The rotor position is detected by a Hall sensor, with the output of Hall sensor applied to the HIN+ and HIN- pins. This sensor can be either a 4 pin 'naked' Hall device or of the 3 pin buffered switching type. For a 4 pin device the differential Hall output signal is connected to the HIN+ and HIN- pins. For a buffered Hall sensor the Hall device output is attached to the HIN+ pin, with a pull-up attached if needed, whilst the HIN- pin has an external potential divider attached to hold the pin at half V_{REF} . When HIN+ is high in relation to HIN-, OUT2 is the active drive.

PWM Pin - External PWM Signal Input for PWM Speed Control Mode

In PWM speed control mode, external PWM signal is applied at this PWM pin to control the motors speed. The duty ratio of the PWM signal input to this pin controls the fan motor speed by varying the output PWM drive directly.

CPWM Pin

Internal motor control triangular wave is generated based on the capacitor on this pin. A capacitor of 100pF ($C_{PWM} = 100\text{pF}$), will provide a triangular wave of 36kHz (typ). The VCONT and RMI signals are compared with this triangular wave to generate the speed control PWM drive and minimum speed control clamp points. The output PWM drive frequency is same as the triangular waveform frequency.

FG/RD Pin

FG is the Frequency Generator (tachometer) output and is a buffered signal from the Hall sensor. RD is the fan locked status detector. FG and RD are open-drain outputs and will require external pull-up resistors. Typically a pull-up resistor of 10k Ω is recommended from FG and RD pins to the supply voltage.

RF Pin

The current limiter is activated when the voltage between current detection resistor exceeds 0.25V between GND and RF. The current limiter is activated at $I_O = 250\text{mA}$ when $R_F = 1\Omega$. The current limit is set with a R_F resistor between RF pin and GND pin.

RMI Pin – Minimum Speed Setting Pin

RMI is the minimum speed setting pin. DC voltage on this pin sets minimum speed value; If you do not use RMI (minimum speed control), please connect it to 5VREG.

VCONT Pin – DC Voltage Speed Control

VCONT is DC voltage inputs speed control pin. The voltage on the VCONT pin is compared with the triangular oscillation on the CPWM pin to generate the output drive PWM signal. For the control method, refer to the timing chart.

REGH/5VREG Pin

Please insert capacitor value 1 μF between 5VREG and GND for regulated output voltage stabilization; insert capacitor value 1 μF value between V_{DD} and REGH for stable output voltage.

OUT1 and OUT2 pin

OUT1 and OUT2 pins provide H-bridge driver output for fan and motor coil connection.

V_{DD} – Device Supply Voltage

This provides the supply for the device.

GND – Supply Return

This is the device supply ground return pin for control signal.

Application Note (Cont.)

Speed Control

This device allows both DC voltage input and PWM signal input for speed control. Typically only one of the method is used to control the motor speed. In DC voltage speed control mode, the voltage on the VCONT pin is compared with the CPWM triangular wave to generate internal PWM signal to drive the output. In PWM speed control mode, the PWM signal on the PWM pin directly controls the output PWM drive.

The typical application circuits shows the two speed control methods.

1. Speed Control by PWM Pin

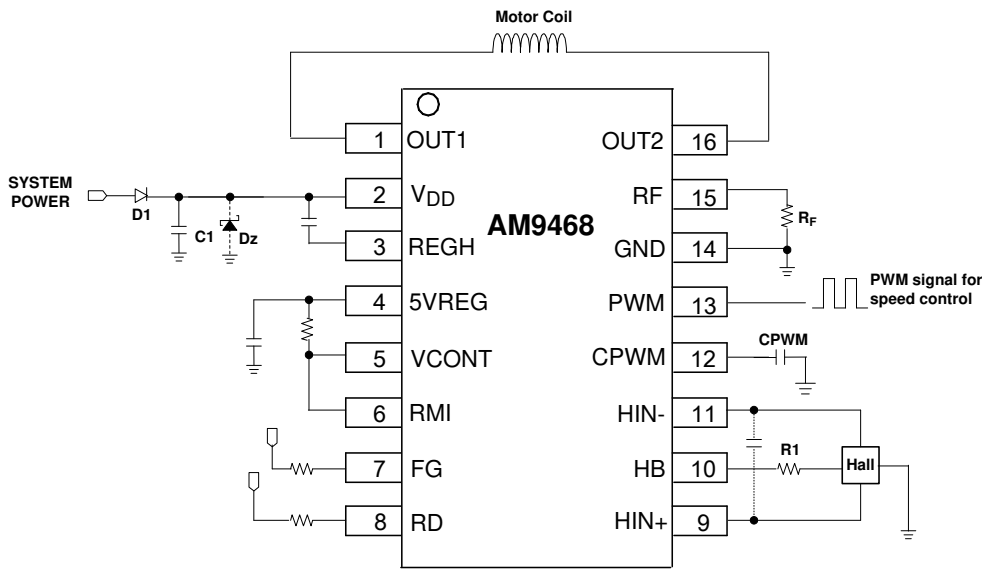

2. Speed Control by VCONT/RMI Pin

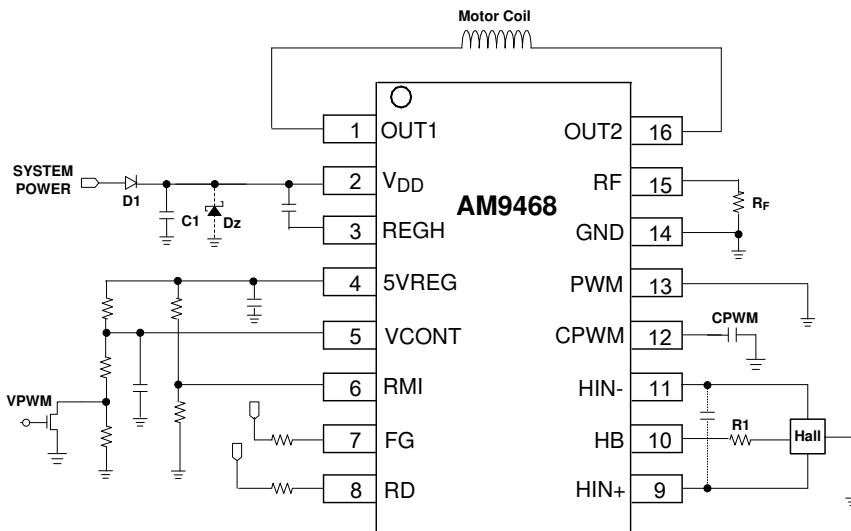

Typical Operating Characteristics

Average Supply Current

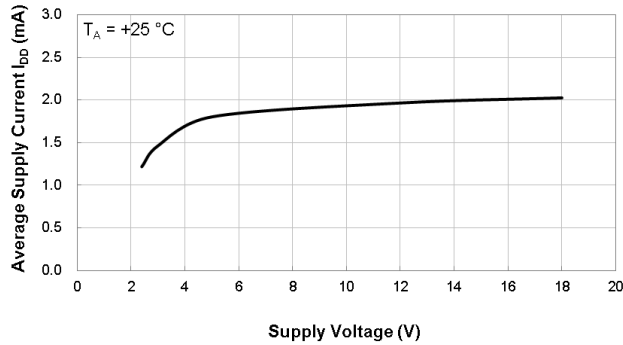

Average Supply Current vs. Supply Voltage

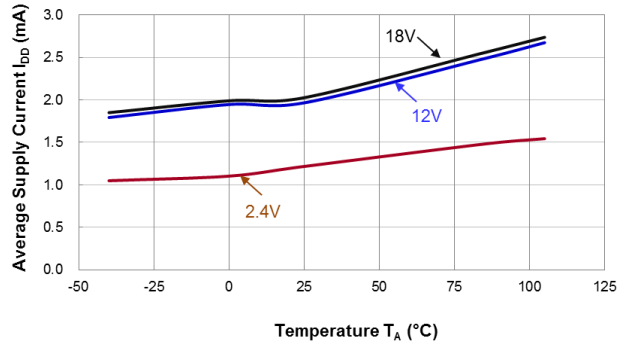

Average Supply Current vs. Temperature

Lock Detect $t_{LCK_DET_ON}$ and Shutdown t_{OFF} Periods

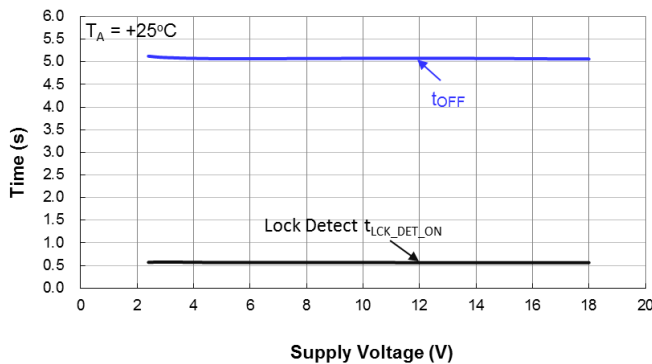

Lock Detect $t_{LCK_DET_ON}$ And t_{OFF} vs. Supply Voltage

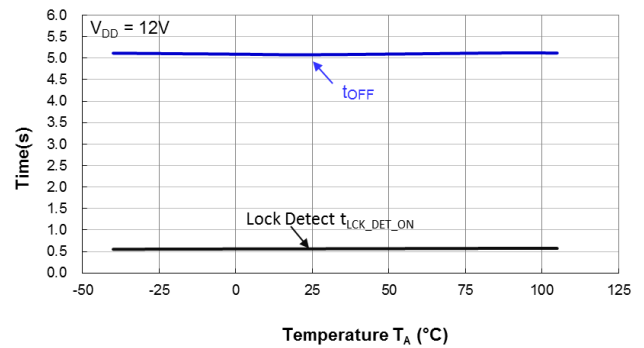

Lock Detect $t_{LCK_DET_ON}$ And t_{OFF} vs. Temperature

Current Limits

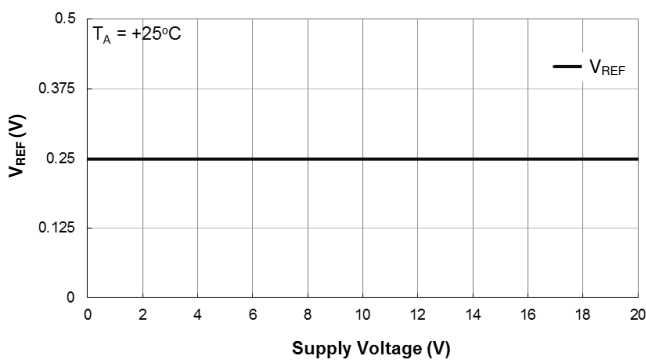

Current limit (250mV) vs. Supply Voltage

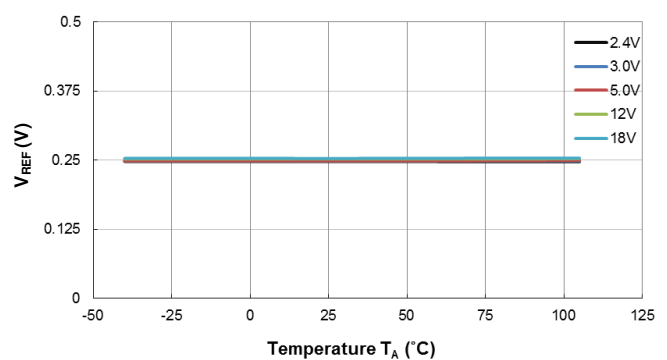

Current Limit (250mV) vs. Temperature

Typical Operating Characteristics (Cont.)

AM9468 Total Resistance

Total H-Bridge Path Resistance – Total $R_{DS(ON)}$ of High Side and Low Side Switches

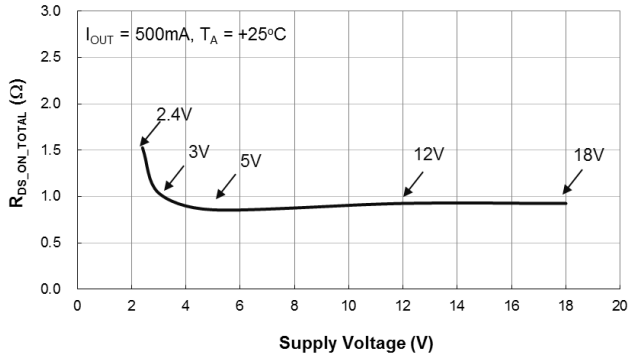

High+Low Side Resistance $R_{DS_ON_TOTAL}$ vs. Supply Voltage

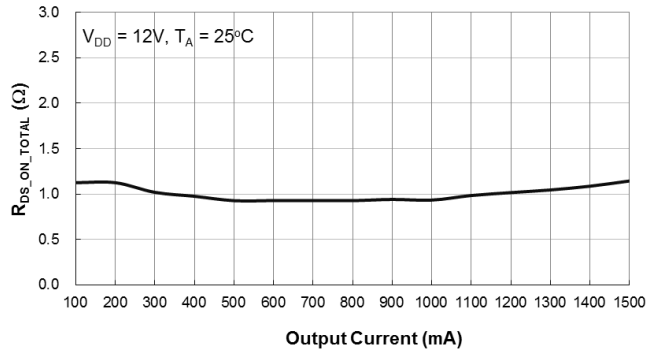

High+Low Side Resistance $R_{DS_ON_TOTAL}$ vs. Current

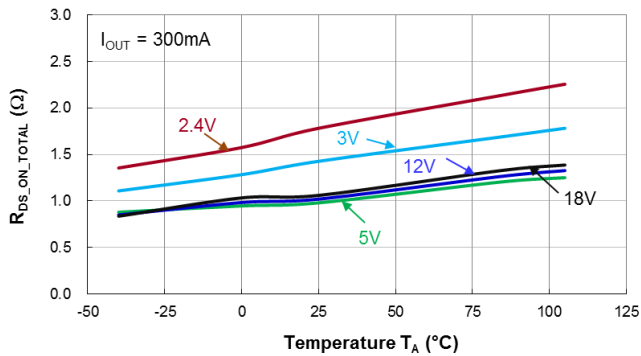

High+Low Side Resistance $R_{DS_ON_TOTAL}$ vs. Temperature

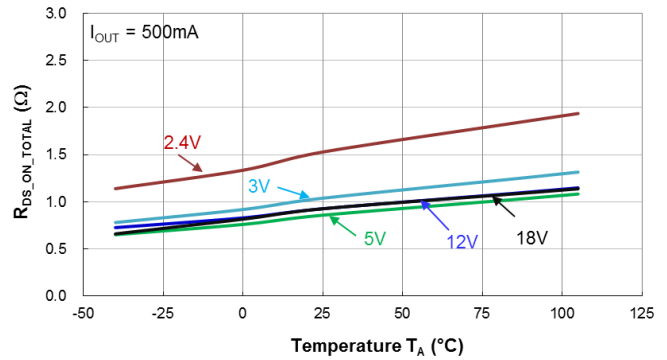

High+Low Side Resistance $R_{DS_ON_TOTAL}$ vs. Temperature

NEW PRODUCT

Thermal Performance

TSSOP-16 Power Dissipation De-rating Curve 1 (Note 13)

T _A (°C)	-40	0	25	50	60	70	80	85	90	95	100	105	110	120	125	130	140	150
P _D (mW)	3,520	3,520	3,520	2,816	2,534	2,253	1,971	1,830	1,690	1,549	1,408	1,267	1,126	845	704	563	282	0

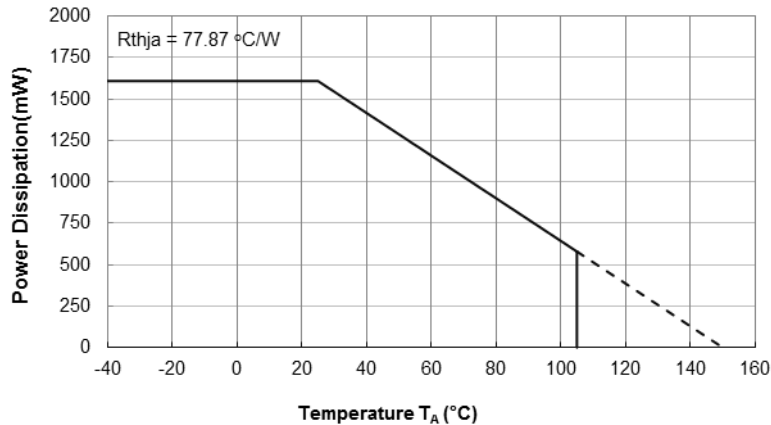

TSSOP-16 Thermal Derating Curve

Note 13: TSSOP-16 is soldered on FR-4 substrate 4-layer 1.6mm thickness PCB board, calculated in accordance with JESD 51-7.

TSSOP-16 Power Dissipation De-rating Curve 2 (Note 14)

T _A (°C)	-40	0	25	50	60	70	80	85	90	95	100	105	110	120	125	130	140	150
P _D (mW)	2,090	2,090	2,090	1,672	1,505	1,338	1,170	1,087	1,003	920	836	752	669	502	418	334	167	0

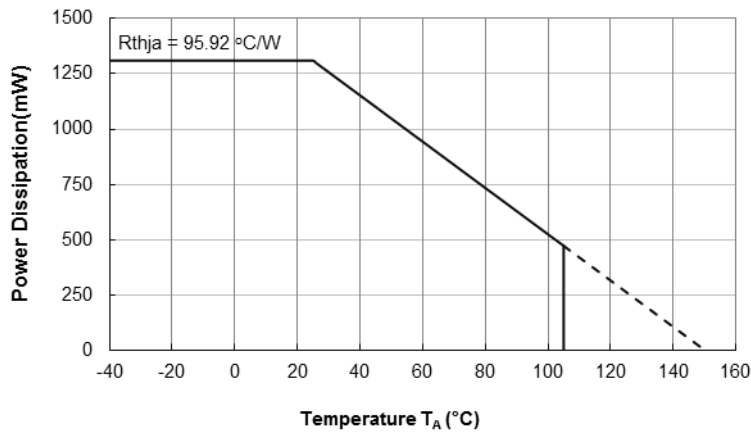

TSSOP-16 Thermal Derating Curve
(Custom Circular PCB with Centre Hole Cut-Out)

Note 14: TSSOP-16 is soldered to the circular PCB diameter 1.2" with the center circular cutout diameter of 0.53". The Hall element space cut-out is 0.12"x0.08". 2-layer 2oz.copper FR-4 PCB (1.6mm thickness) with partial copper flood on the bottom layer.

Thermal Performance

Circular PCB Dimensions

The circular PCB diameter is 1.2" with the centre circular cut-out diameter of 0.53". The Hall element space cut-out is 0.12"x0.08". 2-layer 2oz.copper FR-4 PCB (1.6mm thickness) with partial copper flood on the bottom layer.

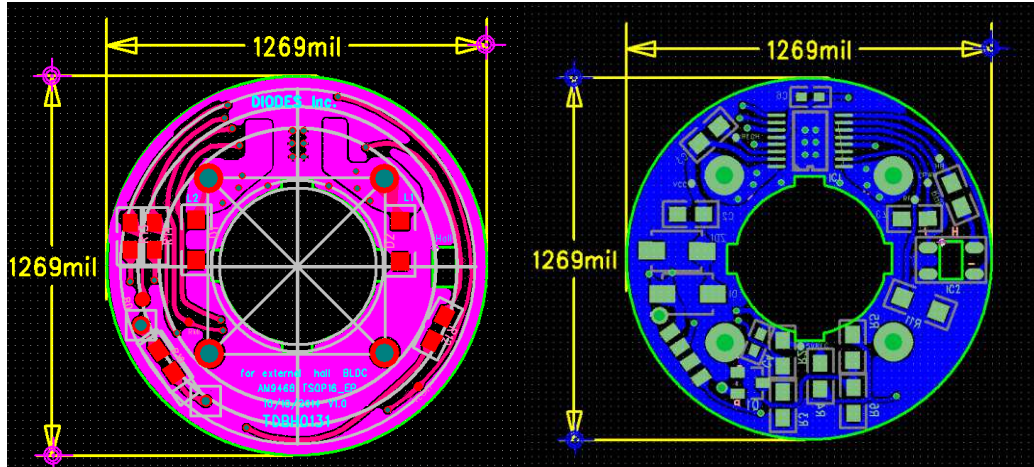

Custom Circular PCB – Top View

Custom Circular PCB – Bottom View

Ordering Information

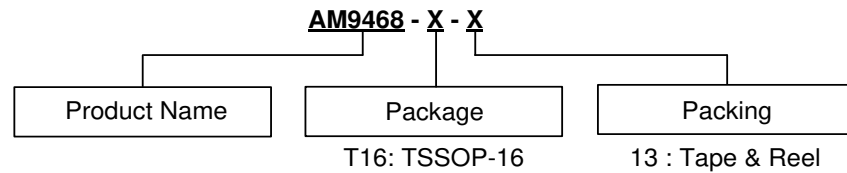

Part Number	Package Code	Packaging	13" Tape and Reel	
			Quantity	Part Number Suffix
AM9468-T16-13	T16	TSSOP-16	2500/Tape & Reel	-13

Marking Information

(1) Package Type: TSSOP-16

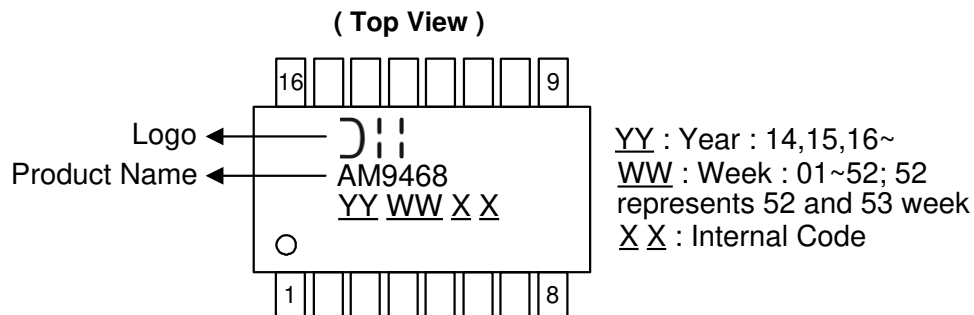

Package Outline Dimensions

Please see <http://www.diodes.com/package-outlines.html> for the latest version.

(1) Package Type: TSSOP-16

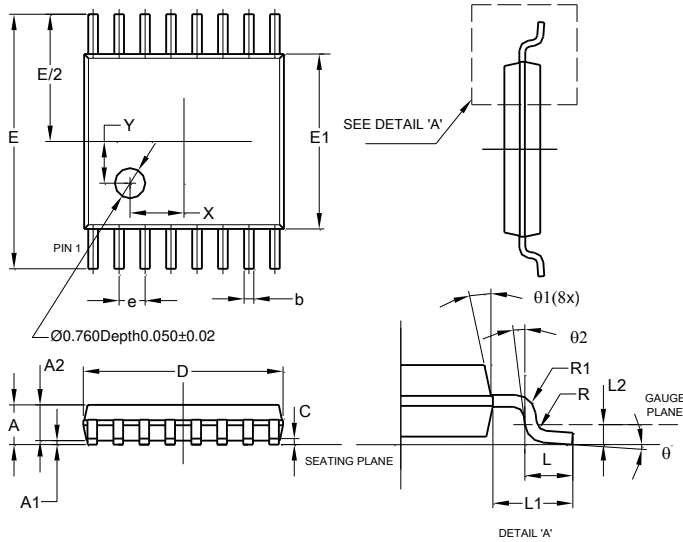

TSSOP-16			
Dim	Min	Max	Typ
A	-	1.08	-
A1	0.05	0.15	-
A2	0.80	0.93	-
b	0.19	0.30	-
c	0.09	0.20	-
D	4.90	5.10	-
E	6.40 BSC		
E1	4.30	4.50	-
e	0.65 BSC		
L	0.45	0.75	-
L1	1.00 REF		
L2	0.25 BSC		
R / R1	0.09	-	-
X	-	-	1.350
Y	-	-	1.050
θ	0°	8°	-
$\theta 1$	5°	15°	-
$\theta 2$	0°	-	-
All Dimensions in mm			

Suggested Pad Layout

Please see <http://www.diodes.com/package-outlines.html> for the latest version.

(1) Package Type: TSSOP-16

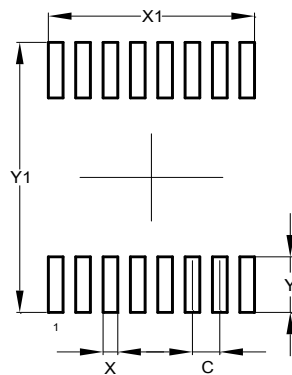

Dimensions	Value (in mm)
C	0.650
X	0.350
X1	4.900
Y	1.400
Y1	6.800

IMPORTANT NOTICE

DIODES INCORPORATED MAKES NO WARRANTY OF ANY KIND, EXPRESS OR IMPLIED, WITH REGARDS TO THIS DOCUMENT, INCLUDING, BUT NOT LIMITED TO, THE IMPLIED WARRANTIES OF MERCHANTABILITY AND FITNESS FOR A PARTICULAR PURPOSE (AND THEIR EQUIVALENTS UNDER THE LAWS OF ANY JURISDICTION).

Diodes Incorporated and its subsidiaries reserve the right to make modifications, enhancements, improvements, corrections or other changes without further notice to this document and any product described herein. Diodes Incorporated does not assume any liability arising out of the application or use of this document or any product described herein; neither does Diodes Incorporated convey any license under its patent or trademark rights, nor the rights of others. Any Customer or user of this document or products described herein in such applications shall assume all risks of such use and will agree to hold Diodes Incorporated and all the companies whose products are represented on Diodes Incorporated website, harmless against all damages.

Diodes Incorporated does not warrant or accept any liability whatsoever in respect of any products purchased through unauthorized sales channel. Should Customers purchase or use Diodes Incorporated products for any unintended or unauthorized application, Customers shall indemnify and hold Diodes Incorporated and its representatives harmless against all claims, damages, expenses, and attorney fees arising out of, directly or indirectly, any claim of personal injury or death associated with such unintended or unauthorized application.

Products described herein may be covered by one or more United States, international or foreign patents pending. Product names and markings noted herein may also be covered by one or more United States, international or foreign trademarks.

This document is written in English but may be translated into multiple languages for reference. Only the English version of this document is the final and determinative format released by Diodes Incorporated.

LIFE SUPPORT

Diodes Incorporated products are specifically not authorized for use as critical components in life support devices or systems without the express written approval of the Chief Executive Officer of Diodes Incorporated. As used herein:

A. Life support devices or systems are devices or systems which:

1. are intended to implant into the body, or
2. support or sustain life and whose failure to perform when properly used in accordance with instructions for use provided in the labeling can be reasonably expected to result in significant injury to the user.

B. A critical component is any component in a life support device or system whose failure to perform can be reasonably expected to cause the failure of the life support device or to affect its safety or effectiveness.

Customers represent that they have all necessary expertise in the safety and regulatory ramifications of their life support devices or systems, and acknowledge and agree that they are solely responsible for all legal, regulatory and safety-related requirements concerning their products and any use of Diodes Incorporated products in such safety-critical, life support devices or systems, notwithstanding any devices- or systems-related information or support that may be provided by Diodes Incorporated. Further, Customers must fully indemnify Diodes Incorporated and its representatives against any damages arising out of the use of Diodes Incorporated products in such safety-critical, life support devices or systems.

Copyright © 2016, Diodes Incorporated

www.diodes.com