



Chipsmall Limited consists of a professional team with an average of over 10 year of expertise in the distribution of electronic components. Based in Hongkong, we have already established firm and mutual-benefit business relationships with customers from,Europe,America and south Asia,supplying obsolete and hard-to-find components to meet their specific needs.

With the principle of “Quality Parts,Customers Priority,Honest Operation,and Considerate Service”,our business mainly focus on the distribution of electronic components. Line cards we deal with include Microchip,ALPS,ROHM,Xilinx,Pulse,ON,Everlight and Freescale. Main products comprise IC,Modules,Potentiometer,IC Socket,Relay,Connector.Our parts cover such applications as commercial,industrial, and automotives areas.

We are looking forward to setting up business relationship with you and hope to provide you with the best service and solution. Let us make a better world for our industry!



Contact us

Tel: +86-755-8981 8866 Fax: +86-755-8427 6832

Email & Skype: info@chipsmall.com Web: www.chipsmall.com

Address: A1208, Overseas Decoration Building, #122 Zhenhua RD., Futian, Shenzhen, China



AMIS-30624, NCV70624

I²C Micro-stepping Motor Driver

INTRODUCTION

The AMIS-30624/NCV70624 is a single-chip micro-stepping motor driver with a position controller and control/diagnostic interface. It is ready to build intelligent peripheral systems where up to 32 drivers can be connected to one I²C master. This significantly reduces system complexity.

The chip receives positioning instructions through the bus and subsequently drives the stator coils so the two-phase stepper motor moves to the desired position. The on-chip position controller is configurable (OTP or RAM) for different motor types, positioning ranges and parameters for speed, acceleration and deceleration. Micro-stepping allows silent motor operation and increased positioning resolution. The advanced motion qualification mode enables verification of the complete mechanical system in function of the selected motion parameters. The AMIS-30624/NCV70624 can easily be connected to an I²C bus where the I²C master can fetch specific status information like actual position, error flags, etc. from each individual slave node.

An integrated sensorless step-loss detection prevents the positioner from losing steps and stops the motor when running into stall. This enables silent, yet accurate position calibrations during a referencing run and allows semi-closed loop operation when approaching the mechanical end-stops.

The chip is implemented in I2T100 technology, enabling both high voltage analog circuitry and digital functionality on the same chip. The NCV70624 is fully compatible with the automotive voltage requirements.

PRODUCT FEATURES

Motor Driver

- Micro-Stepping Technology
- Sensorless Step-Loss Detection
- Peak Current Up to 800 mA
- Fixed Frequency PWM Current-Control
- Selectable PWM Frequency
- Automatic Selection of Fast and Slow Decay Mode
- No external Fly-back Diodes Required
- 14 V/24 V Compliant
- Motion Qualification Mode (Note 1)

Controller with RAM and OTP Memory

- Position Controller
- Configurable Speeds and Acceleration
- Input to Connect Optional Motion Switch

I²C Interface

- Bi-Directional 2-Wire Bus for Inter IC Control

- Field Programmable Node Addresses
- Full Diagnostics and Status Information

Protection

- Overcurrent Protection
- Undervoltage Management
- Open-circuit Detection
- High Temperature Warning and Management
- Low Temperature Flag

EMI Compatibility

- High Voltage Outputs with Slope Control

Patents

- US 7,271,993
- US 7,288,956
- This is a Pb-Free Device
- NCV Prefix for Automotive and Other Applications Requiring Site and Control Changes

1. Not applicable for "Product Versions NCV70624DW010G, NCV70624DW010R2G"



ON Semiconductor®

<http://onsemi.com>

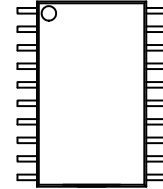

SOIC-20
4 or DW010 SUFFIX
CASE 751AQ

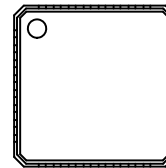

NQFP-32
5 SUFFIX
CASE 560AA

ORDERING INFORMATION

See detailed ordering and shipping information in the package dimensions section on page 2 of this data sheet.

AMIS-30624, NCV70624

APPLICATIONS

The AMIS-30624/NCV70624 is ideally suited for small positioning applications. Target markets include: automotive (headlamp alignment, HVAC, idle control, cruise control), industrial equipment (lighting, fluid control, labeling, process control, XYZ tables, robots) and building

automation (HVAC, surveillance, satellite dish, renewable energy systems). Suitable applications typically have multiple axes or require mechatronic solutions with the driver chip mounted directly on the motor.

Table 1. ORDERING INFORMATION

Part No.	Peak Current	End Market/Version	Package*	Shipping†
AMIS30624C6244G	800 mA	Industrial High Voltage Version	SOIC-20 (Pb-Free)	Tube/Tray
AMIS30624C6244RG	800 mA		SOIC-20 (Pb-Free)	Tape & Reel
AMIS30624C6245G	800 mA		NQFP-32 (7 x 7 mm) (Pb-Free)	Tube/Tray
AMIS30624C6245RG	800 mA		NQFP-32 (7 x 7 mm) (Pb-Free)	Tape & Reel
NCV70624DW010G	800 mA	Automotive High Temperature Version	SOIC-20 (Pb-Free)	Tube/Tray
NCV70624DW010R2G	800 mA		SOIC-20 (Pb-Free)	Tape & Reel

*For additional information on our Pb-Free strategy and soldering details, please download the ON Semiconductor Soldering and Mounting Techniques Reference Manual, SOLDERRM/D.

†For information on tape and reel specifications, including part orientation and tape sizes, please refer to our Tape and Reel Packaging Specification Brochure, BRD8011/D.

QUICK REFERENCE DATA

Table 2. ABSOLUTE MAXIMUM RATINGS

Parameter		Min	Max	Unit
V_{BB}, V_{HW}, V_{SWI}	Supply voltage, hardwired address and SWI pins	-0.3	+40 (Note 2)	V
T_J	Junction temperature range (Note 3)	-50	+175	°C
T_{st}	Storage temperature	-55	+160	°C
V_{esd} (Note 4)	Human Body Model (HBM) Electrostatic discharge voltage on pins	-2	+2	kV
	Machine Model (MM) Electrostatic discharge voltage on pins	-200	+200	V

Stresses exceeding Maximum Ratings may damage the device. Maximum Ratings are stress ratings only. Functional operation above the Recommended Operating Conditions is not implied. Extended exposure to stresses above the Recommended Operating Conditions may affect device reliability.

2. For limited time: $V_{BB} < 0.5$ s, SWI and HW pins < 1.0 s.

3. The circuit functionality is not guaranteed.

4. HBM according to AEC-Q100: EIA-JESD22-A114-B (100 pF via 1.5 k Ω) and MM according to AEC-Q100: EIA-JESD22-A115-A.

Table 3. OPERATING RANGES

Parameter		Min	Max	Unit
V_{BB}	Supply voltage	+6.5	+29	V
T_J	Operating temperature range	-40	+165	°C

AMIS-30624, NCV70624

Table of Contents

General Description	1	Positioning Parameters	11
Product Features	1	Structural Description	14
Applications	2	Functions Description	15
Ordering Information	2	Position Controller	15
Quick Reference Data	2	Main Control and Register	22
Maximum Ratings	2	Autarkic Functionality in Undervoltage Condition ...	24
Block Diagram	3	OTP Register	25
Pin Description	4	Priority Encoder	30
Package Thermal Resistance	5	Motordriver	32
DC Parameters	6	I ² C Bus Description	37
AC Parameters	8	I ² C Application Commands	42
Typical Application	10	Package Outlines	50

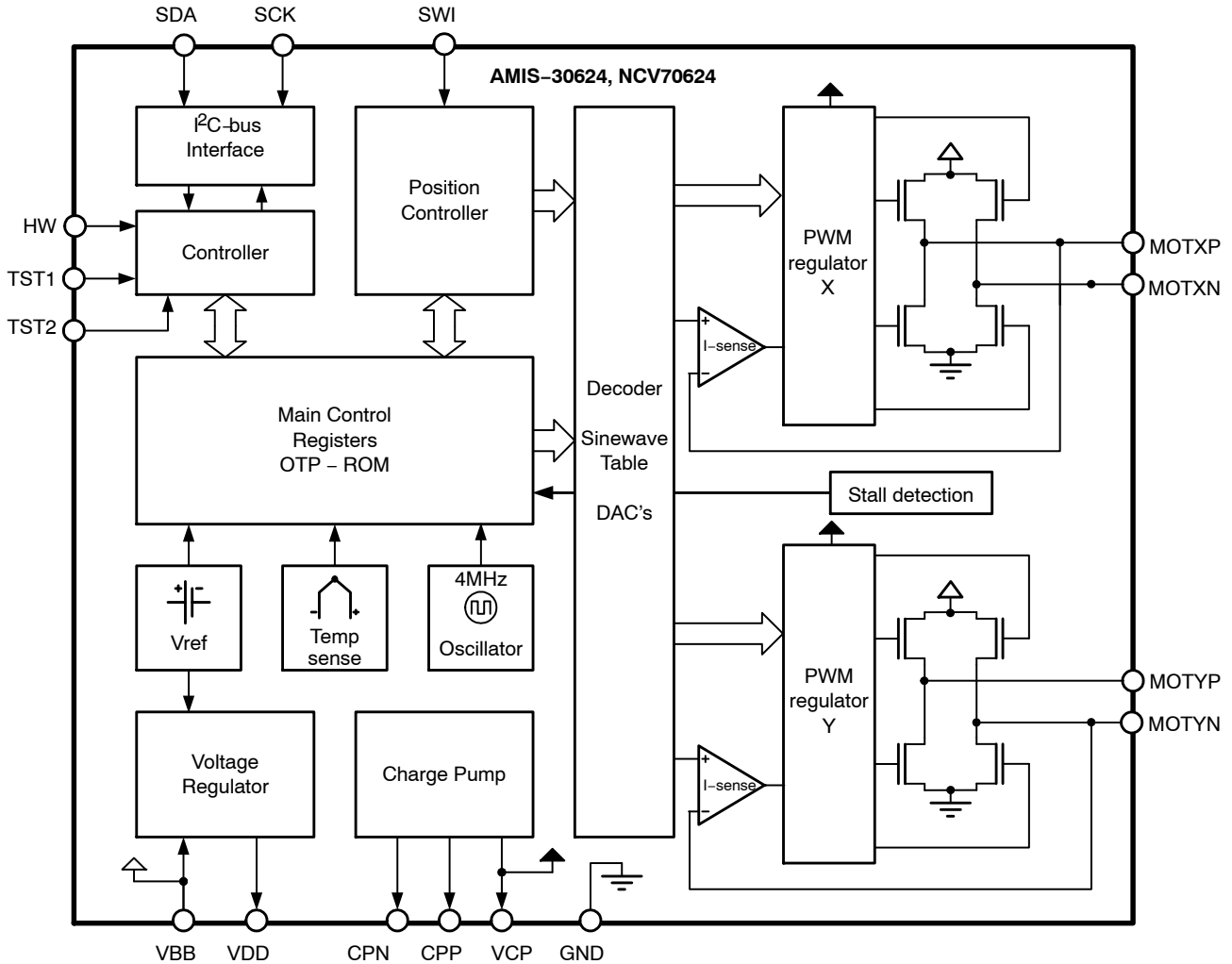

Figure 1. Block Diagram

AMIS-30624, NCV70624

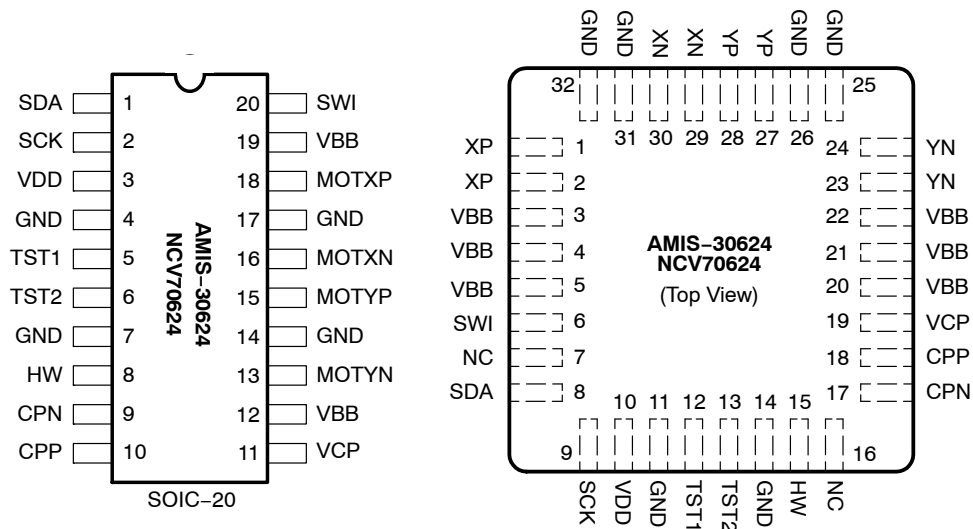

Figure 2. SOIC-20 and NQFP-32 Pin-out

Table 4. PIN DESCRIPTION

Pin Name	Pin Description	SOIC-20	NQFP-32
SDA	I ² C serial data line	1	8
SCK	I ² C serial clock line	2	9
V _{DD}	Internal supply (needs external decoupling capacitor)	3	10
GND	Ground, heat sink	4, 7, 14, 17	11, 14, 25, 26, 31, 32
TST1	Test pin (to be tied to ground in normal operation)	5	12
TST2	Test pin (to be left open in normal operation: internally pulled up)	6	13
HW	Hard wired address bit	8	15
CPN	Negative connection of pump-capacitor (charge pump)	9	17
CPP	Positive connection of pump-capacitor (charge pump)	10	18
VCP	Charge-pump filter-capacitor	11	19
V _{BB}	Battery voltage supply	12, 19	3, 4, 5, 20, 21, 22
MOTYN	Negative end of phase Y coil	13	23, 24
MOTYP	Positive end of phase Y coil	15	27, 28
MOTXN	Negative end of phase X coil	16	29, 30
MOTXP	Positive end of phase X coil	18	1, 2
SWI	Switch input	20	6
NC	Not connected (to be tied to ground)		7, 16

PACKAGE THERMAL RESISTANCE

The AMIS–30624/NCV70624 is available in SOIC–20 or optimized NQFP–32 packages. For cooling optimizations, the NQFP has an exposed thermal pad which has to be soldered to the PCB ground plane. The ground plane needs thermal vias to conduct the heat to the bottom layer. Figures 3 and 4 give examples for good power distribution solutions.

For precise thermal cooling calculations the major thermal resistances of the devices are given. The thermal media to which the power of the devices has to be given are:

- Static environmental air (via the case)
- PCB board copper area (via the device pins and exposed pad)

The thermal resistances are presented in Table 5: DC Parameters.

Package	Rth Junction-to-Leads and Exposed Pad - Rthjp	Rth Junction-to-Leads Rthjp	Rth Junction-to-Ambient Rthja (1SOP)	Rth Junction-to-Ambient Rthja (2S2P)
SOIC–20		19	62	39
NQFP–32	0,95		60	30

The Rthja for 2S2P is simulated conform to JESD–51 as follows:

- A 4–layer printed circuit board with inner power planes and outer (top and bottom) signal layers is used
- Board thickness is 1.46 mm (FR4 PCB material)
- The 2 signal layers: 70 μm thick copper with an area of 5500 mm² copper and 20% conductivity

The major thermal resistances of the device are the Rth from the junction to the ambient (Rthja) and the overall Rth from the junction to the leads (Rthjp).

The NQFP device is designed to provide superior thermal performance. Using an exposed die pad on the bottom surface of the package is mainly contributing to this performance. In order to take full advantage of the exposed pad, it is most important that the PCB has features to conduct heat away from the package. A thermal grounded pad with thermal vias can achieve this.

In the table below, one can find the values for the Rthja and Rthjp, simulated according to the JESD–51 norm:

- The 2 power internal planes: 36 μm thick copper with an area of 5500 mm² copper and 90% conductivity

The Rthja for 1SOP is simulated conform to JESD–51 as follows:

- A 1–layer printed circuit board with only 1 layer
- Board thickness is 1.46 mm (FR4 PCB material)
- The layer has a thickness of 70 μm copper with an area of 5500 mm² copper and 20% conductivity

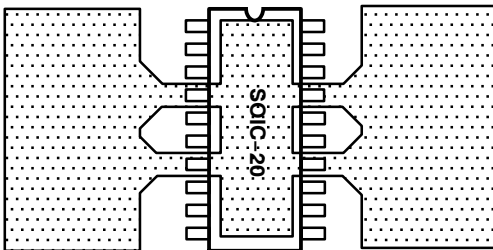

Figure 3. Example of SOIC–20 PCB Ground Plane Layout (preferred layout at top and bottom)

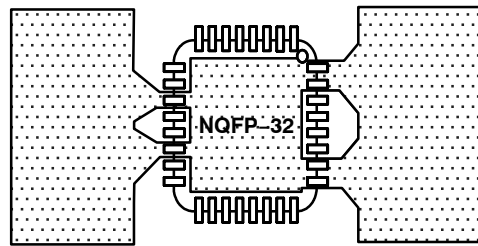

Figure 4. Example of NQFP–32 PCB Ground Plane Layout (preferred layout at top and bottom)

DC PARAMETERS

The DC parameters are guaranteed overtemperature and V_{BB} in the operating range, unless otherwise specified. Convention: currents flowing into the circuit are defined as positive.

Table 5. DC PARAMETERS

Symbol	Pin(s)	Parameter	Test Conditions	Min	Typ	Max	Unit
MOTORDRIVER							
$I_{MSmax,Peak}$	MOTXP MOTXN MOTYP MOTYN	Max current through motor coil in normal operation	$V_{BB} = 14\text{ V}$		800		mA
$I_{MSmax,RMS}$		Max rms current through coil in normal operation	$V_{BB} = 14\text{ V}$		570		mA
I_{MSabs}		Absolute error on coil current (Note 5)	$V_{BB} = 14\text{ V}$	-10		10	%
I_{MSrel}		Matching of X & Y coil currents	$V_{BB} = 14\text{ V}$	-7	0	7	%
$R_{DS(on)}$		On resistance for each motor pin at I_{MSmax} (Note 6)	$V_{BB} = 12\text{ V}, T_j = 50^\circ\text{C}$		0.50	1	Ω
	$V_{BB} = 8\text{ V}, T_j = 50^\circ\text{C}$			0.55	1	Ω	
	$V_{BB} = 12\text{ V}, T_j = 150^\circ\text{C}$			0.70	1	Ω	
	$V_{BB} = 8\text{ V}, T_j = 150^\circ\text{C}$			0.85	1	Ω	
I_{MSL}		Pulldown current	HiZ mode, $V_{BB} = 7.8\text{ V}$		2		mA

I²C SERIAL INTERFACE

V_{IL}	SDA SCK	Input level low (Note 11)		-0.5		$0.3 * V_{DD}$	V
V_{IH}		Input level high (Note 12)		$0.7 * V_{DD}$		$V_{DD} + 0.5$	V
V_{nL}		Noise margin at the LOW level for each connected device (including hysteresis)		$0.1 * V_{DD}$			V
V_{nH}		Noise margin at the HIGH level for each connected device (including hysteresis)		$0.2 * V_{DD}$			

THERMAL WARNING & SHUTDOWN

T_{tw}		Thermal warning (Notes 7 and 8)		138	145	152	$^\circ\text{C}$
T_{tsd}		Thermal shutdown (Note 9)			$T_{tw} + 10$		$^\circ\text{C}$
T_{low}		Low temperature warning (Note 9)				$T_{tw} - 155$	$^\circ\text{C}$

SUPPLY AND VOLTAGE REGULATOR

V_{bbOTP}	V_{BB}	Supply voltage for OTP zapping (Note 10)		9.0		10.0	V
UV_1		Stop voltage high threshold		7.8	8.4	8.9	V
UV_2		Stop voltage low threshold		7.1	7.5	8.0	V
I_{bat}		Total current consumption	Unloaded outputs $V_{BB} = 29\text{ V}$			3.50	10.0

5. Tested in production for 800 mA, 400 mA, 200 mA and 100 mA current settings for both X and Y coil.
6. Not measured in production. Guaranteed by design.
7. Parameter guaranteed by trimming relevant OTP's in production test at $143^\circ\text{C} (\pm 5^\circ\text{C})$ and $V_{BB} = 14\text{ V}$.
8. No more than 100 cumulated hours in life time above T_w .
9. Thermal shutdown and low temperature warning are derived from thermal warning. Guaranteed by design.
10. A buffer capacitor of minimum $100\ \mu\text{F}$ is needed between V_{BB} and GND. Short connections to the power supply are recommended.
11. If input voltages $< -0.3\text{ V}$, than a resistor between $22\ \Omega$ to $100\ \Omega$ needs to be put in series.
12. If the I²C-bus is operated in Fast Mode $V_{IHmin} = 0.7 * V_{DD}$.

AMIS-30624, NCV70624

Table 5. DC PARAMETERS

Symbol	Pin(s)	Parameter	Test Conditions	Min	Typ	Max	Unit
--------	--------	-----------	-----------------	-----	-----	-----	------

SUPPLY AND VOLTAGE REGULATOR

V_{DD}	V_{DD}	Regulated internal supply (Note 13)	$8\text{ V} < V_{BB} < 29\text{ V}$	4.75	5	5.50	V
$V_{ddReset}$		Digital supply reset level @ power down (Note 14)				4.5	V
I_{ddLim}		Current limitation	Pin shorted to ground $V_{BB} = 14\text{ V}$				45

SWITCH INPUT AND HARDWARE ADDRESS INPUT

R_{t_OFF}	SWI HW	Switch OPEN resistance (Note 15)		10			k Ω
R_{t_ON}		Switch ON resistance (Note 15)	Switch to GND or V_{BB}			2	k Ω
V_{bb_sw}		V_{BB} range for guaranteed operation of SWI and HW		6		29	V
I_{lim_sw}		Current limitation	Short to GND or V_{bat} $V_{BB} = 29\text{ V}$	20	30	45	mA

TEST PIN

V_{ihigh}	TST	Input level high	$V_{BB} = 14\text{ V}$	$0.7 * V_{dd}$			V
V_{ilow}		Input level low	$V_{BB} = 14\text{ V}$			$0.3 * V_{dd}$	V
HW_{hyst}		Hysteresis	$V_{BB} = 14\text{ V}$	$0.075 * V_{dd}$			

CHARGE PUMP

V_{cp}	VCP	Output voltage	$6\text{ V} \leq V_{BB} \leq 14\text{ V}$		$2 * V_{BB} - 2.5$		V
			$14\text{ V} \leq V_{BB} \leq 30\text{ V}$	$V_{BB} + 10$		$V_{BB} + 15$	V
C_{buffer}		External buffer capacitor		220		470	nF
C_{pump}	CPP CPN	External pump capacitor		220		470	nF

MOTION QUALIFICATION MODE OUTPUT (Note 16)

V_{OUT}	SWI	Output voltage swing	TestBemf I ² C command		0 – 4.85		V
R_{OUT}		Output impedance	Service mode I ² C command		2		k Ω
A_v		Gain = V_{SWI} / V_{BEMF}	Service mode I ² C command		0.50		

PACKAGE THERMAL RESISTANCE VALUES

R_{thja}	SO	Thermal resistance junction to ambient (2S2P)	Simulated conform JEDEC JESD51		39		K/W
R_{thjp}	SO	Thermal resistance junction to leads			19		K/W
R_{thja}	NQ	Thermal resistance junction to ambient (2S2P)			30		K/W
R_{thjp}	NQ	Thermal resistance junction to leads and exposed pad			0.95		K/W

13. Pin V_{DD} must not be used for any external supply

14. The RAM content will not be altered above this voltage.

15. External resistance value seen from pin SWI or HW, including 1 k Ω series resistor. For the switch OPEN, the maximum allowed leakage current is represented by a minimum resistance seen from the pin.

16. Not applicable for "Product Versions NCV70624DW010G, NCV70624DW010R2G"

AC PARAMETERS

The AC parameters are guaranteed for temperature and V_{BB} in the operating range unless otherwise specified.

Table 6. AC PARAMETERS

Symbol	Pin(s)	Parameter	Test Conditions	Min	Typ	Max	Unit
--------	--------	-----------	-----------------	-----	-----	-----	------

POWERUP

T_{pu}		Power-up time	Guaranteed by design			10	ms
----------	--	---------------	----------------------	--	--	----	----

INTERNAL OSCILLATOR

f_{osc}		Frequency of internal oscillator	$V_{BB} = 14\text{ V}$	3.6	4.0	4.4	MHz
-----------	--	----------------------------------	------------------------	-----	-----	-----	-----

I²C TRANSCEIVER (STANDARD MODE)

f_{SCL}	SDA SCK	SCL clock frequency				100	kHz
$t_{HD,START}$		Hold time (repeated) START condition. After this period the first clock pulse is generated.		4.0			μs
t_{LOW}		LOW period of the SCK clock		4.7			μs
t_{HIGH}		HIGH period of the SCK clock		4.0			μs
$t_{SU,START}$		Set-up time for a repeated START condition		4.7			μs
$t_{HD,DATA}$		Data hold time for I ² C bus devices		0 (Note 18)		3.45 (Note 19)	μs
$t_{SU,DATA}$		Data set-up time		250			ns
t_R		Rise time of SDA and SCK signals				1.0	μs
t_F		Fall time of SDA and SCK signals				0.3	μs
$t_{SU,STOP}$		Set-up time for STOP condition		4.0			μs
t_{BUF}		Bus free time between STOP and START condition		4.7			μs

I²C TRANSCEIVER (FAST MODE)

f_{SCL}	SDA SCK	SCL clock frequency				360	kHz
$t_{HD,START}$		Hold time (repeated) START condition. After this period the first clock pulse is generated.		0.6			μs
t_{LOW}		LOW period of the SCK clock		1.3			μs
t_{HIGH}		HIGH period of the SCK clock		0.6			μs
$t_{SU,START}$		Set-up time for a repeated START condition		0.6			μs
$t_{HD,DATA}$		Data hold time for I ² C bus devices		0 (Note 18)		0.9 (Note 19)	μs
$t_{SU,DATA}$		Data set-up time		100 (Note 20)			ns
t_R		Rise time of SDA and SCK signals		20 + 0.1 C_B		300	ns
t_F		Fall time of SDA and SCK signals		20 + 0.1 C_B		300	ns
$t_{SU,STOP}$		Set-up time for STOP condition		0.6			μs
t_{BUF}		Bus free time between STOP and START condition		1.3			μs

17. The maximum number of connected I²C devices is dependent on the number of available addresses and the maximum bus capacitance to still guarantee the rise and fall times of the bus signals.
18. An I²C device must internally provide a hold time of at least 300 ns for the SDA signal (referred to the V_{IHmin} of the SCL signal) to bridge the undefined region of the falling edge of SCL.
19. The maximum $t_{HD,DATA}$ has only to be met if the device does not stretch the LOW period (t_{LOW}) of the SCL signal.
20. A Fast-mode I²C-bus device can be used in a standard-mode I²C bus system, but the requirement $t_{SU,DATA} \geq 250\text{ ns}$ must than be met. This will automatically be the case if the device does not stretch the LOW period of the SCL signal. If such a device does stretch the LOW period of the SCL signal, it must output the next data bit to the SDA line $t_{max} + t_{SU,DATA} = 1000 + 250 = 1250\text{ ns}$ (according to the standard-mode I²C-bus specification) before the SCL line is released.

Table 6. AC PARAMETERS

Symbol	Pin(s)	Parameter	Test Conditions	Min	Typ	Max	Unit
SWITCH INPUT AND HARDWARE ADDRESS INPUT							
T_{sw}	SWI HW	Scan pulse period (Note 21)	$V_{BB} = 14\text{ V}$		1024		μs
T_{sw_on}		Scan pulse duration (Note 21)	$V_{BB} = 14\text{ V}$		128		μs

MOTORDRIVER

F_{pwm}	MOTxx	PWM frequency (Note 21)	PWMfreq = 0 (Note 22)	20.6	22.8	25.0	kHz
			PWMfreq = 1 (Note 22)	41.2	45.6	50.0	kHz
F_{jit_depth}		PWM jitter modulation depth	PWMJen = 1 (Note 22)		10		%
T_{brise}		Turn-on transient time	Between 10% and 90%		140		ns
T_{bfall}		Turn-off transient time			130		ns
T_{stab}	Run current stabilization time (Note 21)			29	32	35	ms

CHARGE PUMP

f_{CP}	CPN CPP	Charge pump frequency (Note 21)	$V_{BB} = 14\text{ V}$		250		kHz
----------	------------	---------------------------------	------------------------	--	-----	--	-----

21. Derived from the internal oscillator
 22. See [SetMotorParam](#) and [PWM Regulator](#)

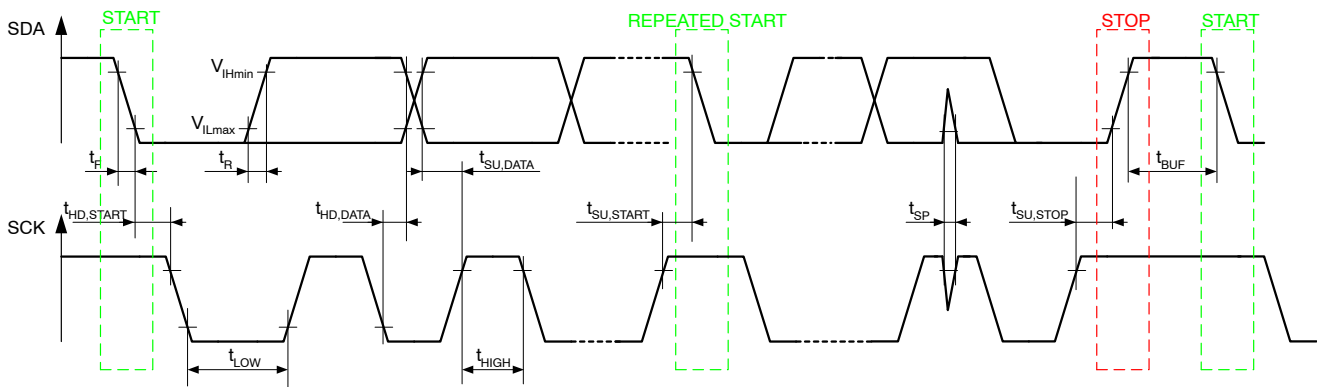

Figure 5. I²C Timing Diagrams

AMIS-30624, NCV70624

Typical Application

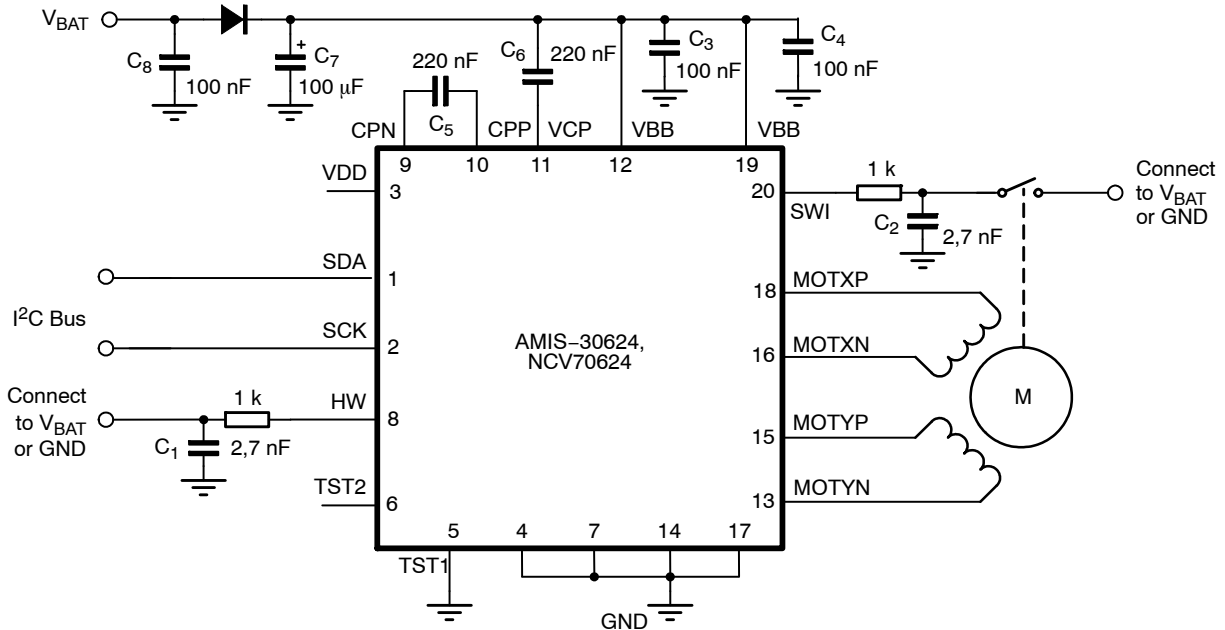

Figure 6. Typical Application Diagram for SO Device

NOTES: All resistors are $\pm 5\%$, 1/4 W

C_1 , C_2 minimum value is 2.7 nF, maximum value is 10 nF

Depending on the application, the ESR value and working voltage of C_7 must be carefully chosen

C_3 and C_4 must be close to pins V_{BB} and GND

C_5 and C_6 must be as close as possible to pins CPN, CPP, VCP, and V_{BB} to reduce EMC radiation

C_9 must be a ceramic capacitor to assure low ESR

POSITIONING PARAMETERS

Stepping Modes

One of four possible stepping modes can be programmed:

- Half-stepping
- 1/4 micro-stepping
- 1/8 micro-stepping
- 1/16 micro-stepping

Maximum Velocity

For each stepping mode, the maximum velocity V_{max} can be programmed to 16 possible values given in the table below.

The accuracy of V_{max} is derived from the internal oscillator. Under special circumstances it is possible to change the V_{max} parameter while a motion is ongoing. All 16 entries for the V_{max} parameter are divided into four groups. When changing V_{max} during a motion the application must take care that the new V_{max} parameter stays within the same group.

Table 7. MAXIMUM VELOCITY SELECTION TABLE

Vmax Index		Vmax (full step/s)	Group	Stepping Mode			
Hex	Dec			Half-stepping (half-step/s)	1/4 th Micro-stepping (micro-step/s)	1/8 th Micro-stepping (micro-step/s)	1/16 th Micro-stepping (micro-step/s)
0	0	99	A	197	395	790	1579
1	1	136	B	273	546	1091	2182
2	2	167		334	668	1335	2670
3	3	197		395	790	1579	3159
4	4	213		425	851	1701	3403
5	5	228		456	912	1823	3647
6	6	243		486	973	1945	3891
7	7	273	C	546	1091	2182	4364
8	8	303		607	1213	2426	4852
9	9	334		668	1335	2670	5341
A	10	364		729	1457	2914	5829
B	11	395		790	1579	3159	6317
C	12	456		912	1823	3647	7294
D	13	546	D	1091	2182	4364	8728
E	14	729		1457	2914	5829	11658
F	15	973		1945	3891	7782	15564

AMIS-30624, NCV70624

Minimum Velocity

Once the maximum velocity is chosen, 16 possible values can be programmed for the minimum velocity V_{min} . The table below provides the obtainable values in full-step/s. The accuracy of V_{min} is derived from the internal oscillator.

Table 8. OBTAINABLE VALUES IN FULL-STEP/s FOR THE MINIMUM VELOCITY

Vmin Index		Vmax Factor	Vmax (Full-step/s)															
			A	B					C					D				
Hex	Dec		99	136	167	197	213	228	243	273	303	334	364	395	456	546	729	973
0	0	1	99	136	167	197	213	228	243	273	303	334	364	395	456	546	729	973
1	1	1/32	3	4	5	6	6	7	7	8	8	10	10	11	13	15	19	27
2	2	2/32	6	8	10	11	12	13	14	15	17	19	21	23	27	31	42	57
3	3	3/32	9	12	15	18	19	21	22	25	27	31	32	36	42	50	65	88
4	4	4/32	12	16	20	24	26	28	30	32	36	40	44	48	55	65	88	118
5	5	5/32	15	21	26	31	32	35	37	42	46	51	55	61	71	84	111	149
6	6	6/32	18	25	31	36	39	42	45	50	55	61	67	72	84	99	134	179
7	7	7/32	21	30	36	43	46	50	52	59	65	72	78	86	99	118	156	210
8	8	8/32	24	33	41	49	52	56	60	67	74	82	90	97	113	134	179	240
9	9	9/32	28	38	47	55	59	64	68	76	84	93	101	111	128	153	202	271
A	10	10/32	31	42	51	61	66	71	75	84	93	103	113	122	141	168	225	301
B	11	11/32	34	47	57	68	72	78	83	93	103	114	124	135	156	187	248	332
C	12	12/32	37	51	62	73	79	85	91	101	113	124	135	147	170	202	271	362
D	13	13/32	40	55	68	80	86	93	98	111	122	135	147	160	185	221	294	393
E	14	14/32	43	59	72	86	93	99	106	118	132	145	158	172	198	237	317	423
F	15	15/32	46	64	78	93	99	107	113	128	141	156	170	185	214	256	340	454

NOTES: The Vmax factor is an approximation.

In case of motion without acceleration (**AccShape** = 1) the length of the steps = $1/V_{min}$. In case of accelerated motion (**AccShape** = 0) the length of the first step is shorter than $1/V_{min}$ depending of **Vmin**, **Vmax** and **Acc**.

AMIS-30624, NCV70624

Acceleration and Deceleration

Sixteen possible values can be programmed for Acc (acceleration and deceleration between Vmin and Vmax). The table below provides the obtainable values in full-step/s². One observes restrictions for some

combinations of acceleration index and maximum speed (gray cells).

The accuracy of Acc is derived from the internal oscillator.

Table 9. ACCELERATION AND DECELERATION SELECTION TABLE

Vmax (FS/s) →		99	136	167	197	213	228	243	273	303	334	364	395	456	546	729	973	
↓ Acc Index																		
Hex	Dec	Acceleration (Full-step/s ²)																
0	0	49								106				473				
1	1	218																
2	2	1004																
3	3	3609																
4	4	6228																
5	5	8848																
6	6	11409																
7	7	13970																
8	8	16531																
9	9	14785	19092															
A	10		21886															
B	11		24447															
C	12		27008															
D	13		29570															
E	14		29570								34925							
F	15		29570								40047							

The formula to compute the number of equivalent full-steps during acceleration phase is:

$$N_{step} = \frac{V_{max}^2 - V_{min}^2}{2 \times Acc}$$

Positioning

The position programmed in command SetPosition is given as a number of (micro-)steps. According to the chosen stepping mode, the position words must be aligned as described in the table below. When using command GotoSecurePosition, data is automatically aligned.

Table 10. POSITION WORD ALIGNMENT

Stepping Mode	Position Word: Pos [15 : 0]																Shift
1/16 th	S	B14	B13	B12	B11	B10	B9	B8	B7	B6	B5	B4	B3	B2	B1	LSB	No shift
1/8 th	S	B13	B12	B11	B10	B9	B8	B7	B6	B5	B4	B3	B2	B1	LSB	0	1-bit left ⇔ ×2
1/4 th	S	B12	B11	B10	B9	B8	B7	B6	B5	B4	B3	B2	B1	LSB	0	0	2-bit left ⇔ ×4
Half-stepping	S	B11	B10	B9	B8	B7	B6	B5	B4	B3	B2	B1	LSB	0	0	0	3-bit left ⇔ ×8
SecurePosition	S	B9	B8	B7	B6	B5	B4	B3	B2	B1	LSB	0	0	0	0	0	No shift

NOTES: LSB: Least Significant Bit

S: Sign bit

Position Ranges

A position is coded by using the binary two’s complement format. According to the positioning commands used and to the chosen stepping mode, the position range will be as shown in the following table.

Table 11. POSITION RANGE

Command	Stepping Mode	Position Range	Full Range Excursion	Number of Bits
SetPosition	Half-stepping	-4096 to +4095	8192 half-steps	13
	1/4 th micro-stepping	-8192 to +8191	16384 micro-steps	14
	1/8 th micro-stepping	-16384 to +16383	32768 micro-steps	15
	1/16 th micro-stepping	-32768 to +32767	65536 micro-steps	16

When using the command SetPosition, although coded on 16 bits, the position word will have to be shifted to the left by a certain number of bits, according to the stepping mode.

Secure Position

A secure position can be programmed. It is coded in 11-bits, thus having a lower resolution than normal positions, as shown in the following table. See also command GotoSecurePosition.

Table 12. SECURE POSITION

Stepping Mode	Secure Position Resolution
Half-stepping	4 half-steps
1/4 th micro-stepping	8 micro-steps (1/4 th)
1/8 th micro-stepping	16 micro-steps (1/8 th)
1/16 th micro-stepping	32 micro-steps (1/16 th)

Important

NOTES: The secure position is disabled in case the programmed value is the reserved code “1000000000” (0x400 or most negative position).
The resolution of the secure position is limited to 9 bit at start-up. The OTP register is copied in RAM as illustrated below. The RAM bits SecPos1 and SecPos0 are set to 0.

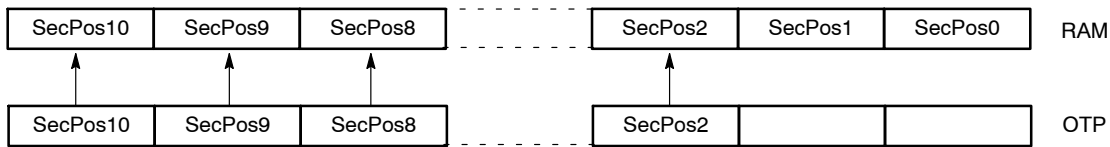

Shaft

A shaft bit, which can be programmed in OTP or with command SetMotorParam, defines whether a positive motion is a clockwise (CW) or counter-clockwise rotation (CCW) (an outer or an inner motion for linear actuators):

- Shaft = 0 ⇒ MOTXP is used as positive pin of the X coil, while MOTXN is the negative one.
- Shaft = 1 ⇒ opposite situation

Exception: in RunVelocity mode, the shaft bit has no function. In this mode the rotational direction is always CW or CCW, which is only determined by the motor wiring.

STRUCTURAL DESCRIPTION

See also the Block Diagram in Figure 1.

Stepper Motordriver

The Motordriver receives the control signals from the control logic. The main features are:

- Two H-bridges, designed to drive a stepper motor with two separated coils. Each coil (X and Y) is driven by one H-bridge, and the driver controls the currents flowing through the coils. The rotational position of the rotor, in unloaded condition, is defined by the ratio of current flowing in X and Y. The torque of the stepper

motor when unloaded is controlled by the magnitude of the currents in X and Y.

- The control block for the H-bridges, including the PWM control, the synchronous rectification and the internal current sensing circuitry.
- The charge pump to allow driving of the H-bridges’ high side transistors.
- Two pre-scale 4-bit DAC’s to set the maximum magnitude of the current through X and Y.

- Two DAC's to set the correct current ratio through X and Y.

Battery voltage monitoring is also performed by this block, which provides the required information to the control logic part. The same applies for detection and reporting of an electrical problem that could occur on the coils or the charge pump.

Control Logic (Position Controller and Main Control)

The control logic block stores the information provided by the I²C interface (in a RAM or an OTP memory) and digitally controls the positioning of the stepper motor in terms of speed and acceleration, by feeding the right signals to the motordriver state machine.

It will take into account the successive positioning commands to properly initiate or stop the stepper motor in order to reach the set point in a minimum time.

It also receives feedback from the motordriver part in order to manage possible problems and decide on internal actions and reporting to the I²C interface.

Motion Detection

Motion detection is based on the back-emf generated internally in the running motor. When the motor is blocked,

e.g. when it hits the end position, the velocity, and as a result also the generated back-emf, is disturbed. The AMIS-30624/NCV70624 senses the back-emf, calculates a moving average and compares the value with two independent threshold levels. If the back-emf disturbance is bigger than the set threshold, the running motor is stopped.

Miscellaneous

The AMIS-30624/NCV70624 also contains the following:

- An internal oscillator, needed for the control logic handler as well as the control logic and the PWM control of the motordriver.
- An internal trimmed voltage source for precise referencing.
- A protection block featuring a thermal shutdown and a power-on-reset circuit.
- A 5 V regulator (from the battery supply) to supply the internal logic circuitry.

FUNCTIONS DESCRIPTION

This chapter describes the following functional blocks in more detail:

- Position controller
- Main control and register, OTP memory + ROM
- Motordriver

The Motion detection and I²C controller are discussed in separate chapters.

Position Controller

Positioning and Motion Control

A positioning command will produce a motion as illustrated in Figure 7. A motion starts with an acceleration phase from minimum velocity (V_{min}) to maximum velocity (V_{max}) and ends with a symmetrical deceleration. This is defined by the control logic according to the position required by the application and the parameters programmed by the application during the configuration phase. The current in the coils is also programmable.

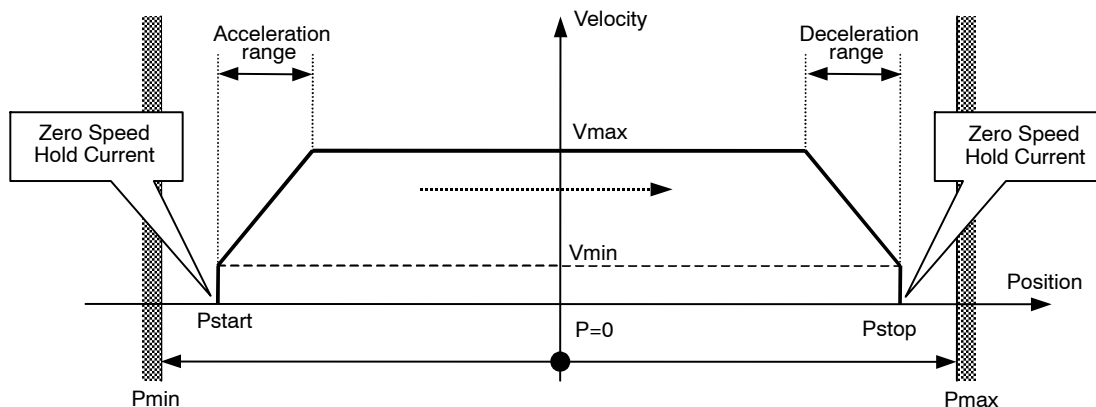

Figure 7. Positioning and Motion Control

Table 13. POSITION RELATED PARAMETERS

Parameter	Reference
Pmax – Pmin	See Positioning
Zero Speed Hold Current	See Ihold
Maximum Current	See Irun
Acceleration and Deceleration	See Acceleration and Deceleration
Vmin	See Minimum Velocity
Vmax	See Maximum Velocity

Different positioning examples are shown in the table below.

Table 14. POSITIONING EXAMPLES

Short motion.	
New positioning command in same direction, shorter or longer, while a motion is running at maximum velocity.	
New positioning command in same direction while in deceleration phase (Note 23) Note: there is no wait time between the deceleration phase and the new acceleration phase.	
New positioning command in reverse direction while motion is running at maximum velocity.	
New positioning command in reverse direction while in deceleration phase.	
New velocity programming while motion is running.	

23. Reaching the end position is always guaranteed, however velocity rounding errors might occur after consecutive accelerations during a deceleration phase. The velocity rounding error will be removed at Vmin (e.g. at end of acceleration or when AccShape=1).

Dual Positioning

A SetDualPosition command allows the user to perform a positioning using two different velocities. The first motion is done with the specified Vmin and Vmax velocities in the SetDualPosition command, with the acceleration (deceleration) parameter already in RAM, to a position Pos1[15:0] also specified in SetDualPosition.

Then a second relative motion to a physical position Pos1[15:0] + Pos2[15:0] is done at the specified Vmin velocity in the SetDualPosition command (no

acceleration). Once the second motion is achieved, the ActPos register is reset to zero, whereas TagPos register is not changed.

When the Secure position is enabled, after the dual positioning, the secure positioning is executed. The figure below gives a detailed overview of the dual positioning function. After the dual positioning is executed an internal flag is set to indicate the AMIS-30624/NCV70624 is referenced.

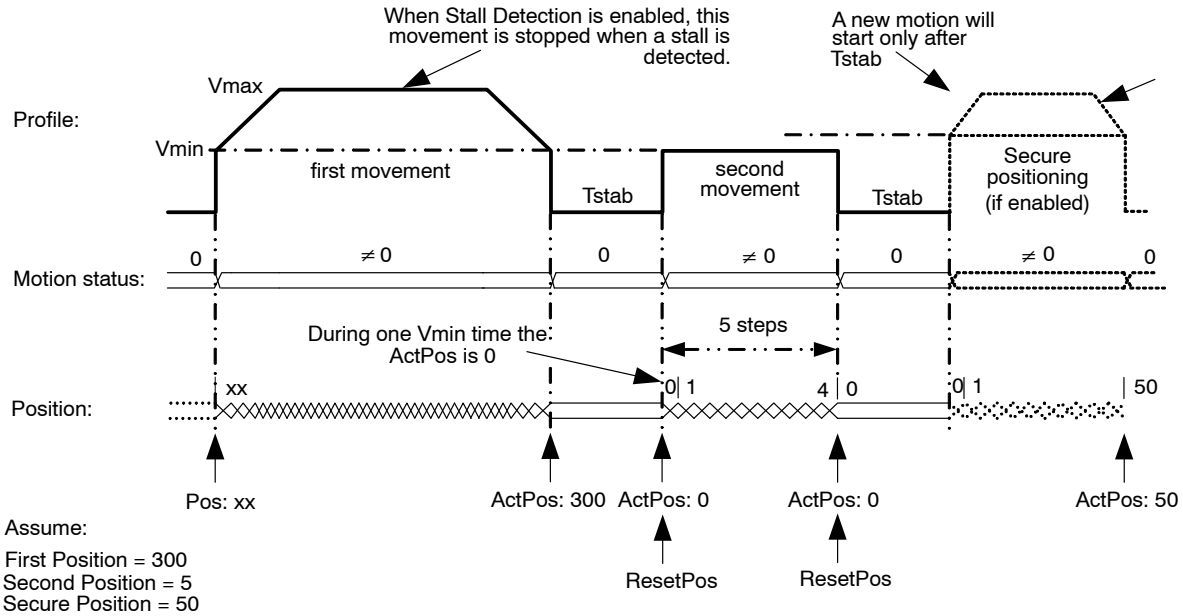

Figure 8. Dual Positioning

Remark: This operation cannot be interrupted or influenced by any further command unless the occurrence of the conditions driving to a motor shutdown or by a HardStop command. Sending a SetDualPosition command while a motion is already ongoing is not recommended.

- 24. The priority encoder is describing the management of states and commands.
- 25. A DualPosition sequence starts by setting TagPos buffer register to SecPos value, provided secure position is enabled otherwise TagPos is reset to zero. If a SetPosition(Short) command is issued during a DualPosition sequence, it will be kept in the position buffer memory and executed afterwards. This applies also for the command GotoSecurePosition.
- 26. Commands such as GetFullStatus1 or GetFullStatus2 will be executed while a Dual Positioning is running.
- 27. The Pos1, Pos2, Vmax and Vmin values programmed in a SetDualPosition command apply only for this sequence. All other motion parameters are used from the RAM registers (programmed for instance by a former SetMotorParam command). After the DualPosition motion is completed, the former Vmin and Vmax become active again.
- 28. Commands ResetPosition, SetDualPosition, and SoftStop will be ignored while a DualPosition sequence is ongoing, and will not be executed afterwards.
- 29. Recommendation: a SetMotorParam command should not be sent during a SetDualPosition sequence: all the motion parameters defined in the command, except Vmin and Vmax, become active immediately.

Position Periodicity

Depending on the stepping mode the position can range from -4096 to +4095 in half-step to -32768 to +32767 in 1/16th micro-stepping mode. One can project all these positions lying on a circle. When executing the command SetPosition, the position controller will set the movement direction in such a way that the traveled distance is minimal.

The figure below illustrates that the moving direction going from ActPos = +30000 to TagPos = -30000 is clockwise.

If a counter clockwise motion is required in this example, several consecutive SetPosition commands can be used. One could also use for larger movements the command RunVelocity.

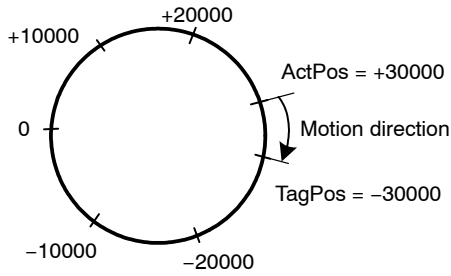

Figure 9. Motion Direction is Function of Difference between ActPos and TagPos

Hardwired Address HW

In the drawing below, a simplified schematic diagram is shown of the HW comparator circuit.

The HW pin is sensed via 2 switches. The DriveHS and DriveLS control lines are alternatively closing the top and bottom switch connecting HW pin with a current to resistor converting. Closing S_{TOP} (DriveHS = 1) will sense a current to GND. In that case the top $I \rightarrow R$ converter output is low, via the closed passing switch S_{PASS_T} this signal is fed to the “R” comparator which output HW_Cmp is high. Closing bottom switch S_{BOT} (DriveLS = 1) will sense a current to V_{BAT} . The corresponding $I \rightarrow R$ converter output is low and via S_{PASS_B} fed to the comparator. The output HW_Cmp will be high.

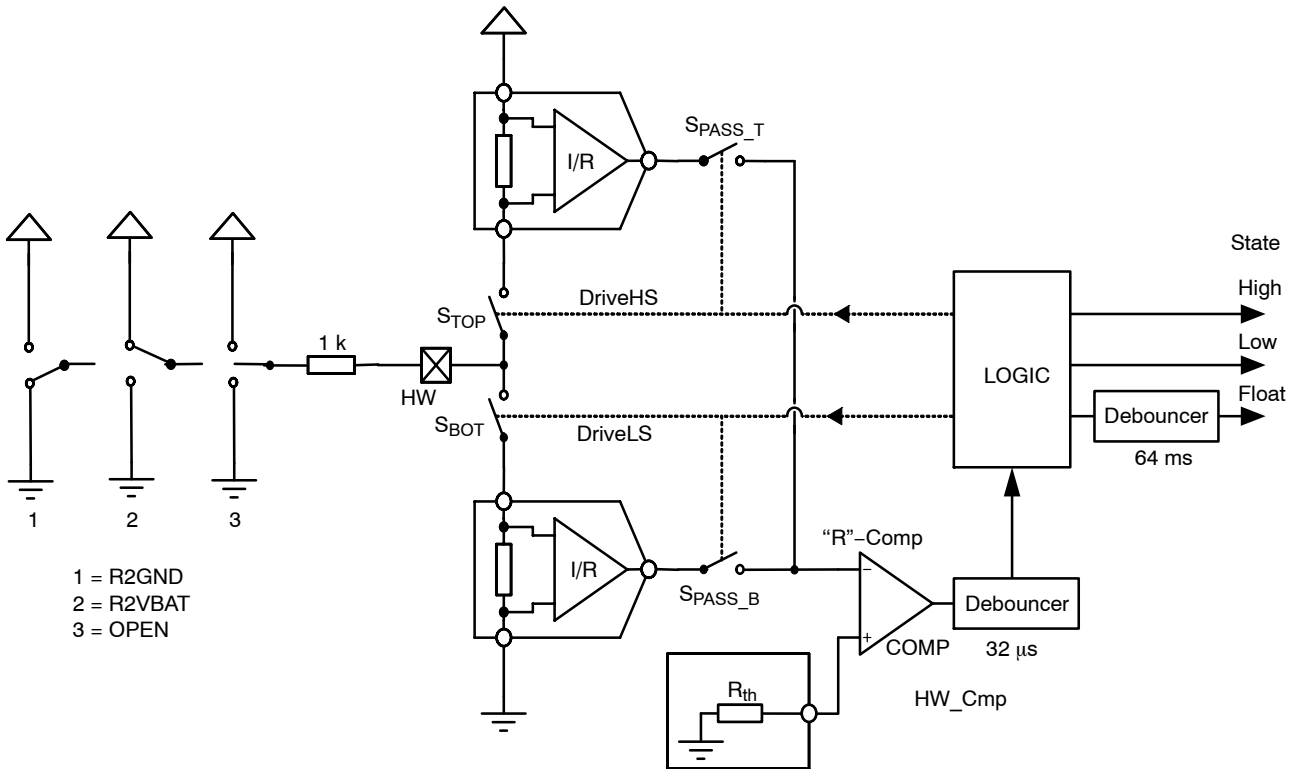

Figure 10. Simplified Schematic Diagram of the HW Comparator

3 cases can be distinguished (see also Figure 10 above):

- HW is connected to ground: R2GND or drawing 1
- HW is connected to VBAT: R2VBAT or drawing 2
- HW is floating: OPEN or drawing 3

Table 15. STATE DIAGRAM OF THE HW COMPARATOR

Previous State	DriveLS	DriveHS	HW_Cmp	New State	Condition	Drawing
Float	1	0	0	Float	R2GND or OPEN	1 or 3
Float	1	0	1	High	R2VBAT	2
Float	0	1	0	Float	R2VBAT or OPEN	2 or 3
Float	0	1	1	Low	R2GND	1
Low	1	0	0	Low	R2GND or OPEN	1 or 3
Low	1	0	1	High	R2VBAT	2
Low	0	1	0	Float	R2VBAT or OPEN	2 or 3
Low	0	1	1	Low	R2GND	1
High	1	0	0	Float	R2GND or OPEN	1 or 3
High	1	0	1	High	R2VBAT	2
High	0	1	0	High	R2VBAT or OPEN	2 or 3
High	0	1	1	Low	R2GND	1

The logic is controlling the correct sequence in closing the switches and in interpreting the 32 μ s debounced HW_Cmp output accordingly. The output of this small state-machine is corresponding to:

- High or address = 1
- Low or address = 0
- Floating

As illustrated in the table above (Table 15), the state is depending on the previous state, the condition of the 2 switch controls (DriveLS and DriveHS) and the output of HW_Cmp. Figure 11 shows an example of a practical case where a connection to VBAT is interrupted.

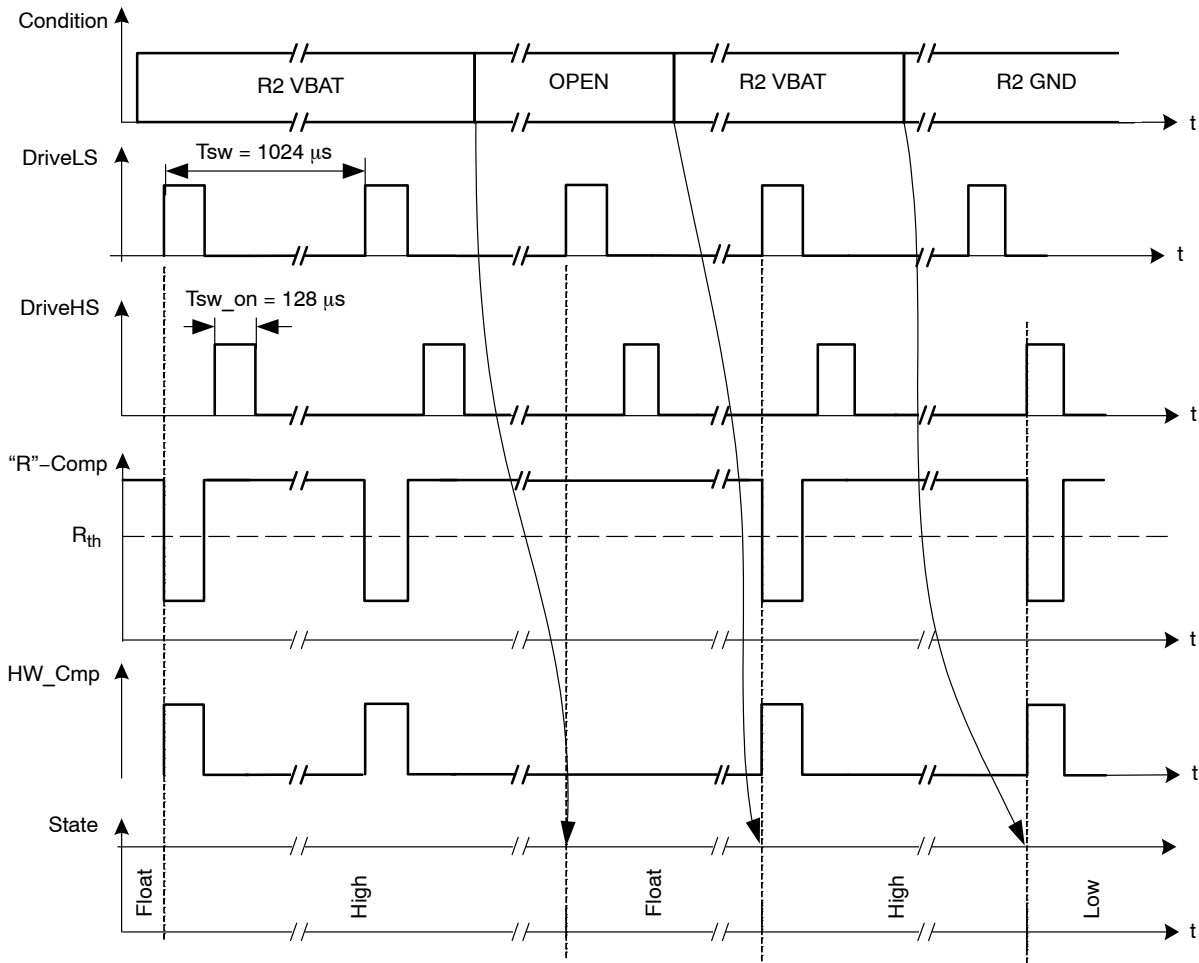

Figure 11. Timing Diagram Showing the Change in States for HW Comparator

R2VBAT

A resistor is connected between VBAT and HW. Every 1024 μs S_{BOT} is closed and a current is sensed. The output of the $I \Rightarrow R$ converter is low and the HW_Cmp output is high. Assuming the previous state was floating, the internal logic will interpret this as a change of state and the new state will be high (see also Table 15). The next time S_{BOT} is closed the same conditions are observed. The previous state was high so based on Table 15 the new state remains unchanged. This high state will be interpreted as HW address = 1.

OPEN

In case the HW connection is lost (broken wire, bad contact in connector) the next time S_{BOT} is closed, this will be sensed. There will be no current, the output of the corresponding $I \Rightarrow R$ converter is high and the HW_Cmp will be low. The previous state was high. Based in Table 15 one can see that the state changes to float. This will trigger

a motion to secure position after a debounce time of 64 ms, which prevents false triggering in case of micro-interruptions of the power supply.

R2GND

If a resistor is connected between HW and the GND, a current is sensed every 1024 μs when S_{TOP} is closed. The output of the top $I \Rightarrow R$ converter is low and as a result the HW_Cmp output switches to high. Again based on the stated diagram in Table 15 one can see that the state will change to Low. This low state will be interpreted as HW address = 0.

External Switch SWI

As illustrated in Figure 12 the SWI comparator is almost identical to HW. The major difference is in the limited number of states. Only open or closed is recognized leading to respectively $ESW = 0$ and $ESW = 1$.

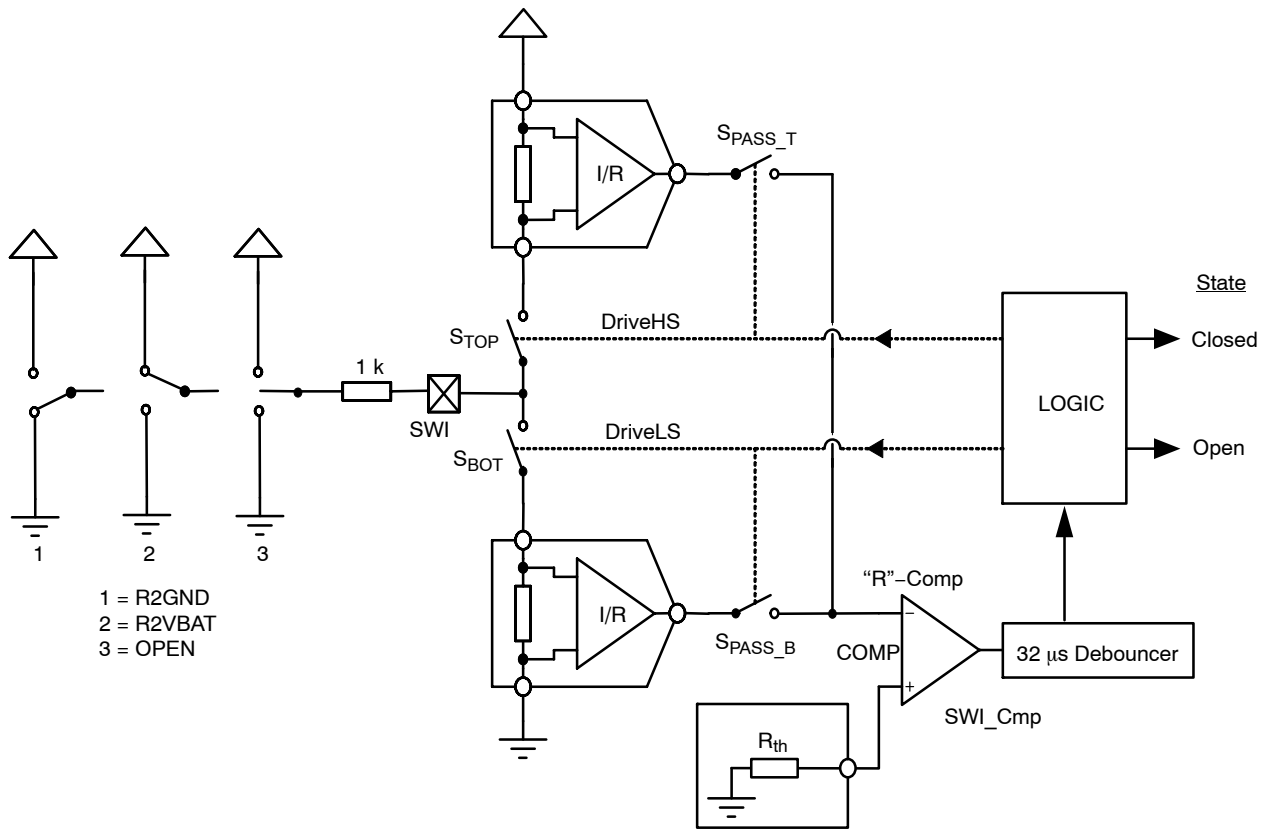

Figure 12. Simplified Schematic Diagram of the SWI Comparator

As illustrated in the drawing above, a change in state is always synchronized with DriveHS or DriveLS. The same synchronization is valid for updating the internal position register. This means that after every current pulse (or closing of STOP or SBOT) the state of the position switch together with the corresponding position is memorized.

The `FullStatus1` command reads back the `<ActPos>` register and the status of ESW. In this way the master node may get synchronous information about the state of the switch together with the position of the motor. See Table 16 below.

Table 16. GetFullStatus1 I²C COMMAND

GetFullStatus1 Response Frame									
Byte	Content	Structure							
		Bit 7	Bit 6	Bit 5	Bit 4	Bit 3	Bit 2	Bit 1	Bit 0
0	Address	1	1	OTP3	OTP2	OTP1	OTP0	HW	1
1	Address	1	1	1	OTP3	OTP2	OTP1	OTP0	HW
2	Data 1	Irun[3:0]				Ihold[3:0]			
3	Data 2	Vmax[3:0]				Vmin[3:0]			
4	Data 3	AccShape	StepMode[1:0]		Shaft	Acc[3:0]			
5	Data 4	vddReset	StepLoss	EIDef	UV2	TSD	TW	Tinfo[1:0]	
6	Data 5	Motion[2:0]			ESW	OVC1	OVC2	Stall	CPFail
7	Data 6	1	1	1	1	1	1	1	1
8	Data 7	AbsThr[3:0]				DelThr[3:0]			

AMIS-30624, NCV70624

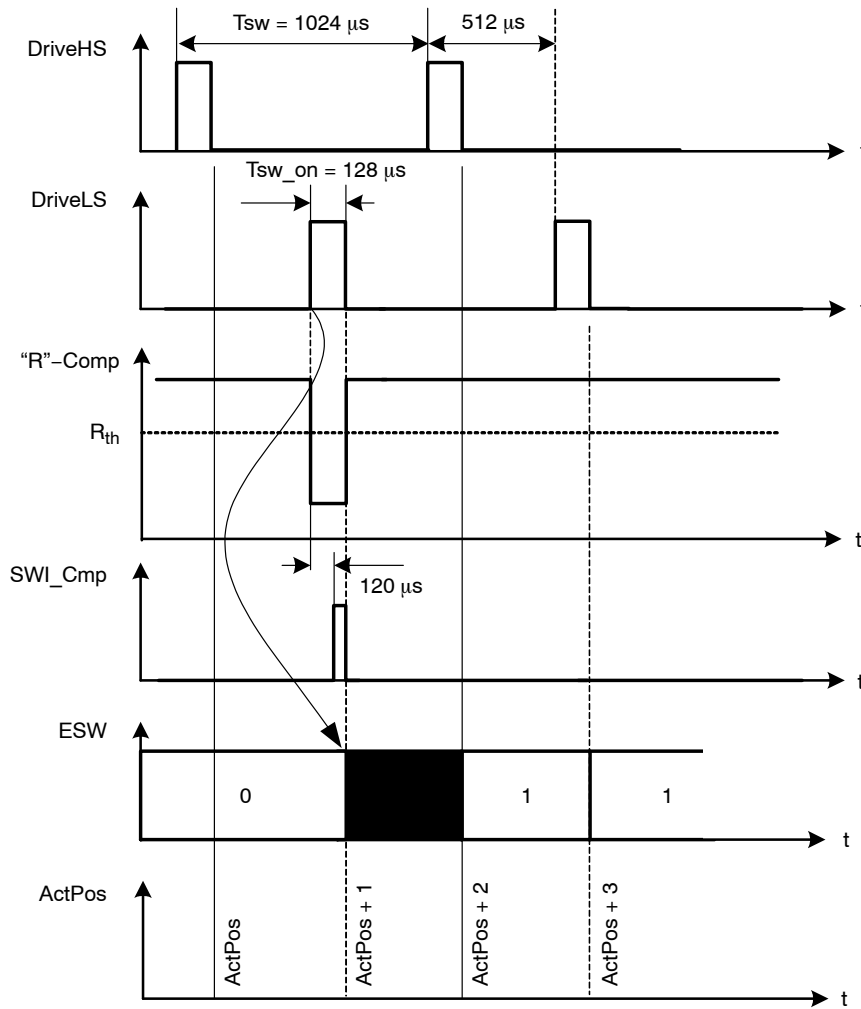

Figure 13. Simplified Timing Diagram Showing the Change in States for SWI Comparator

Main Control and Register, OTP memory + ROM

Power-up Phase

Power-up phase of the AMIS-30624/NCV70624 will not exceed 10 ms. After this phase, the AMIS-30624/NCV70624 is in standby mode, ready to receive I²C messages and execute the associated commands. After power-up, the registers and flags are in the reset state, while some of them are being loaded with the OTP memory content (see Table 19: RAM Registers).

Reset

After power-up, or after a reset occurrence (e.g. a micro-cut on pin V_{BB} has made V_{DD} to go below V_{ddReset}

level), the H-bridges will be in high-impedance mode, and the registers and flags will be in a predetermined position. This is documented in Table 19: RAM Registers and Table 20: Flags Table.

Soft-stop

A soft-stop is an immediate interruption of a motion, but with a deceleration phase. At the end of this action, the register <TagPos> is loaded with the value contained in register <ActPos>, see Table 19: Ram Registers). The circuit is then ready to execute a new positioning command, provided thermal and electrical conditions allow for it.

Thermal Shutdown Mode

When thermal shutdown occurs, the circuit performs a <SoftStop> command and goes to motor shutdown mode (see Figure 14: State Diagram Temperature Management).

Temperature Management

The AMIS-30624/NCV70624 monitors temperature by means of two thresholds and one shutdown level, as

illustrated in the state diagram and illustration of Figure 14: State Diagram Temperature Management below. The only condition to reset flags <TW> and <TSD> (respectively thermal warning and thermal shutdown) is to be at a temperature lower than T_{tw} and to get the occurrence of a `GetFullStatus1` I²C frame.

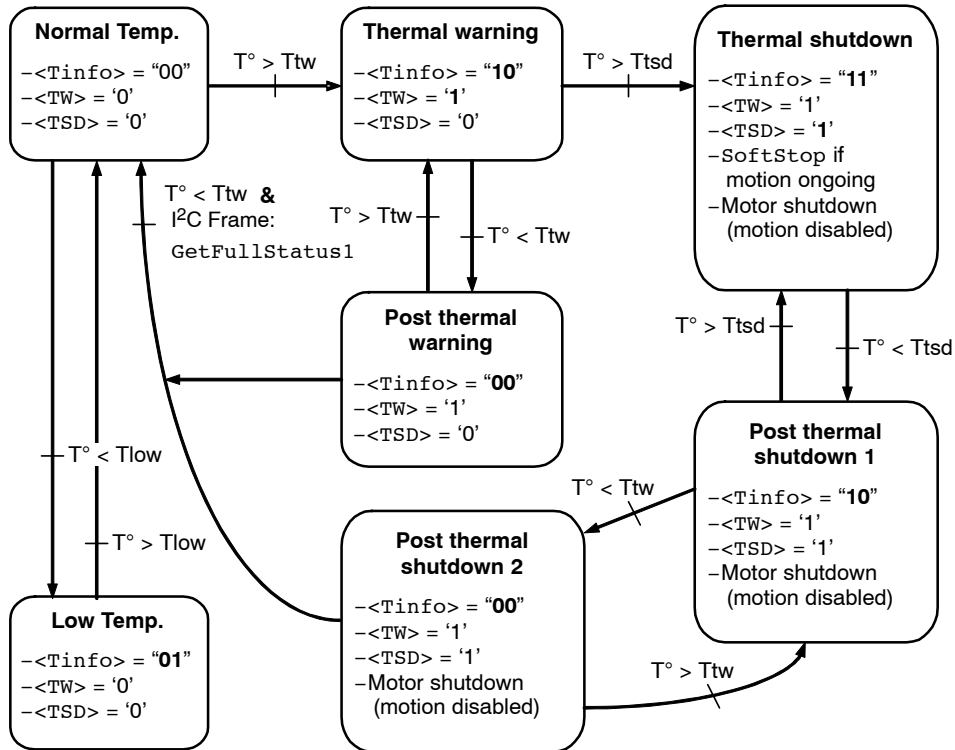

Figure 14. State Diagram Temperature Management

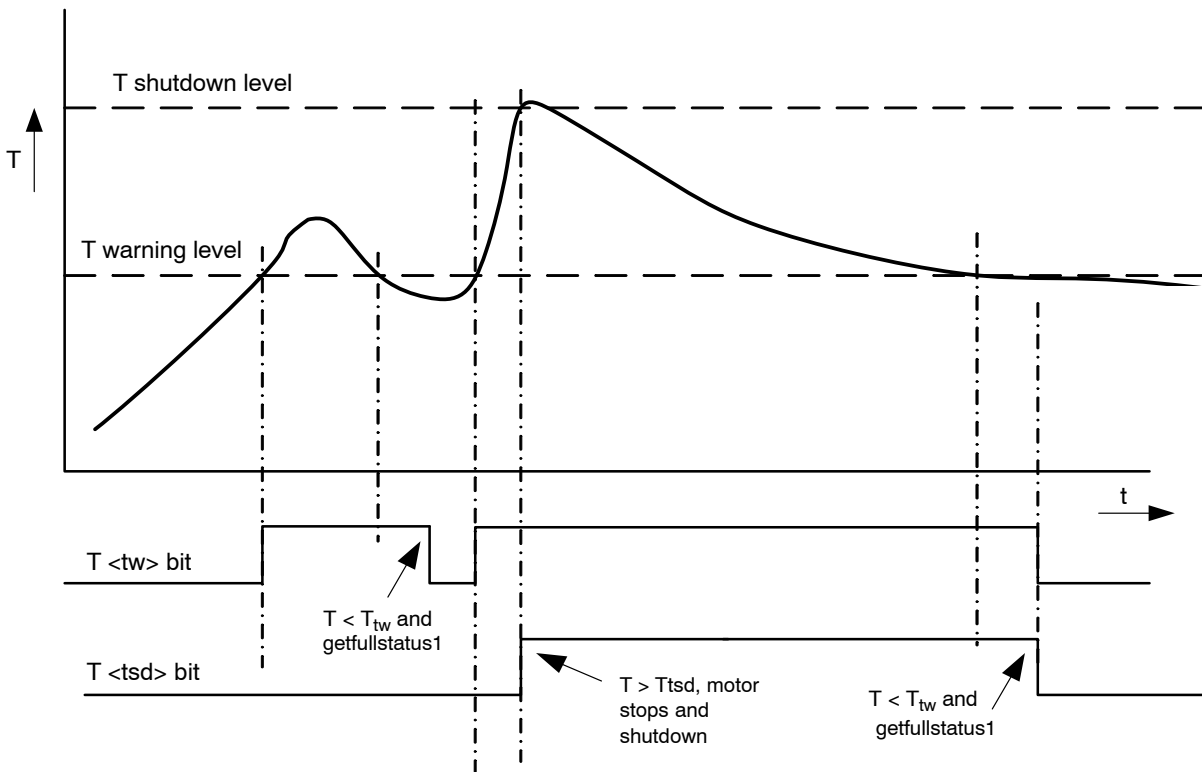

Figure 15. Illustration of Thermal Management Situation

Autarkic Functionality in Under-Voltage Condition

Battery Voltage Management

The AMIS-30624/NCV70624 monitors the battery voltage by means of one threshold and one shutdown level. The only condition to reset flags `<UV2>` and `<StepLoss>` is to recover by a battery voltage higher than UV1 and to receive a `GetFullStatus1` command.

Autarkic Function

The device enters states `<HardUnder>` (see Figure 16), followed by `<ShutUnder>` when V_{BB} is below the UV2 level or `<CPFail> = 1`. The motion is stopped immediately and Target Position (TagPos) is kept and not overwritten by Actual Position (ActPos). The motor is in HiZ state and the flags `<UV2>` and `<StepLoss>` are set to inform the master that the voltage has dropped below UV2 or the charge pump voltage has dropped below the level of the charge pump comparator and loss of steps is possible.

- If in this state V_{BB} becomes $> UV1$ within 15 seconds, then AMIS-30624/NCV70624 returns to `<Stopped>` state. From there, it resumes the interrupted motion and accepts updates of the target position by means of the commands `SetPosition` and

`GotoSecurePosition`, even if the `<UV2>` flag, the `<CPFail>` flag and `<StepLoss>` flags are NOT cleared.

- If however the V_{BB} voltage remains below UV2 level or the charge pump voltage level is below the charge pump comparator for more than 15 seconds, then the device will enter `<Shutdown>` state and the target position is overwritten by Actual Position. This state can be exited only if V_{BB} is $> UV1$, the charge pump voltage is above the charge pump comparator voltage and an incoming command `GetFullStatus1` is received.

Important Notes:

1. In the case of Autarkic positioning, care needs to be taken because accumulated steploss can cause a significant deviation between physical and stored actual position.
2. The `SetDualPosition` command will only be executed after clearing the `<UV2>`, `CPFail` and `<StepLoss>` flags.
3. RAM reset occurs when $V_{dd} < V_{ddReset}$ (digital Power-On-Reset level).
4. The Autarkic function remains active as long as $V_{DD} > V_{ddReset}$.

OTP Register

OTP Memory Structure

The table below shows how the parameters to be stored in the OTP memory are located.

Table 17. OTP MEMORY STRUCTURE

Address	Bit 7	Bit 6	Bit 5	Bit 4	Bit 3	Bit 2	Bit 1	Bit 0
0x00	OSC3	OSC2	OSC1	OSC0	IREF3	IREF2	IREF1	IREF0
0x01	0	TSD2	TSD1	TSD0	BG3	BG2	BG1	BG0
0x02	AbsThr3	AbsThr2	AbsThr1	AbsThr0	PA3	PA2	PA1	PA0
0x03	Irun3	Irun2	Irun1	Irun0	Ihold3	Ihold2	Ihold1	Ihold0
0x04	Vmax3	Vmax2	Vmax1	Vmax0	Vmin3	Vmin2	Vmin1	Vmin0
0x05	SecPos10	SecPos9	SecPos8	Shaft	Acc3	Acc2	Acc1	Acc0
0x06	SecPos7	SecPos6	SecPos5	SecPos4	SecPos3	SecPos2		
0x07	DelThr3	DelThr2	DelThr1	DelThr0	StepMode1	StepMode0	LOCKBT	LOCKBG

Parameters stored at address 0x00 and 0x01 and bit <LOCKBT> are already programmed in the OTP memory at circuit delivery. They correspond to the calibration of the circuit and are just documented here as an indication.

Each OTP bit is at '0' when not zapped. Zapping a bit will set it to '1'. Thus only bits having to be at '1' must be zapped. Zapping of a bit already at '1' is disabled. Each OTP byte will be programmed separately (see command [SetOTPparam](#)). Once OTP programming is completed, bit <LOCKBG> can be zapped to disable future zapping, otherwise any OTP bit at '0' could still be zapped by using a [SetOTPparam](#) command.

Table 18. OTP OVERWRITE PROTECTION

Lock Bit	Protected Bytes
LOCKBT (factory zapped before delivery)	0x00 to 0x01
LOCKBG	0x00 to 0x07

The command used to load the application parameters via the I²C bus in the RAM prior to an OTP Memory programming is [SetMotorParam](#). This allows for a functional verification before using a [SetOTPparam](#) command to program and zap separately one OTP memory byte. A [GetOTPparam](#) command issued after each [SetOTPparam](#) command allows verifying the correct byte zapping.

Note: Zapped bits will become active only after a power cycle. After programming the I²C bits the power cycle has to be performed first to guarantee further communication with the device.

Application Parameters Stored in OTP Memory

Except for the physical address <PA[3:0]> these parameters, although programmed in a non-volatile memory can still be overridden in RAM by a I²C writing operation.

PA[3:0] In combination with hired wired (HW) address, it forms the physical address AD[6:0] of the stepper-motor. Up to 32 stepper motors can theoretically be connected to the same I²C bus.

AbsThr[3:0] Absolute threshold used for the motion detection

Index	AbsThr				AbsThr level (V) (*)
0	0	0	0	0	Disable
1	0	0	0	1	0.5
2	0	0	1	0	1.0
3	0	0	1	1	1.5
4	0	1	0	0	2.0
5	0	1	0	1	2.5
6	0	1	1	0	3.0
7	0	1	1	1	3.5
8	1	0	0	0	4.0
9	1	0	0	1	4.5
A	1	0	1	0	5.0
B	1	0	1	1	5.5
C	1	1	0	0	6.0
D	1	1	0	1	6.5
E	1	1	1	0	7.0
F	1	1	1	1	7.5

(*) Not tested in production. Values are approximations.