



Chipsmall Limited consists of a professional team with an average of over 10 year of expertise in the distribution of electronic components. Based in Hongkong, we have already established firm and mutual-benefit business relationships with customers from,Europe,America and south Asia,supplying obsolete and hard-to-find components to meet their specific needs.

With the principle of "Quality Parts,Customers Priority,Honest Operation,and Considerate Service",our business mainly focus on the distribution of electronic components. Line cards we deal with include Microchip,ALPS,ROHM,Xilinx,Pulse,ON,Everlight and Freescale. Main products comprise IC,Modules,Potentiometer,IC Socket,Relay,Connector.Our parts cover such applications as commercial,industrial, and automotives areas.

We are looking forward to setting up business relationship with you and hope to provide you with the best service and solution. Let us make a better world for our industry!



Contact us

Tel: +86-755-8981 8866 Fax: +86-755-8427 6832

Email & Skype: info@chipsmall.com Web: www.chipsmall.com

Address: A1208, Overseas Decoration Building, #122 Zhenhua RD., Futian, Shenzhen, China



Quad DMOS Full-Bridge PWM Motor Driver

FEATURES AND BENEFITS

- 18 V output rating
- 4 full bridges
- Dual stepper motor driver
- High-current outputs
- 3.3 and 5 V compatible logic
- Synchronous rectification
- Internal undervoltage lockout (UVLO)
- Thermal shutdown circuitry
- Crossover-current protection
- Overcurrent protection
- Low-profile QFN package

PACKAGE:

Package EV, 36-pin QFN
0.90 mm nominal height
with exposed thermal pad

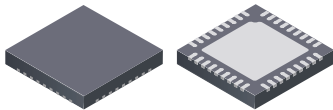

Not to scale

DESCRIPTION

The AMT49701 is a quad DMOS full-bridge driver capable of driving up to two stepper motors or four DC motors. Each full-bridge output is rated up to 1 A and 18 V. The AMT49701 includes fixed off-time pulse-width modulation (PWM) current regulators, along with 2-bit nonlinear DACs (digital-to-analog converters) that allow stepper motors to be controlled in full, half, and quarter steps, and DC motors in forward, reverse, and coast modes. The PWM current regulator uses the Allegro™ patented mixed decay mode for reduced audible motor noise, increased step accuracy, and reduced power dissipation.

Internal synchronous rectification control circuitry is provided to improve power dissipation during PWM operation.

Protection features include thermal shutdown with hysteresis, undervoltage lockout (UVLO) and crossover-current protection. Special power-up sequencing is not required.

The AMT49701 is supplied in the EV package, a 6 mm × 6 mm, 36-pin QFN package with a nominal overall package height of 0.90 mm, and with an exposed thermal pad for enhanced thermal performance. The package is lead (Pb) free, with 100% matte-tin leadframe plating.

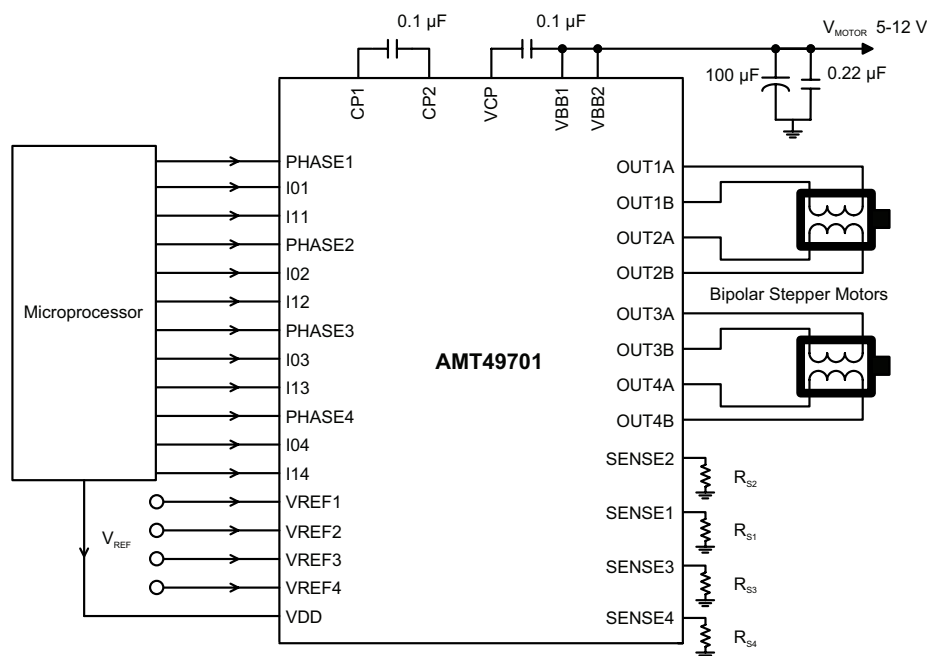

Figure 1: Typical Application Circuit

SELECTION GUIDE

Part Number	Package	Packing
AMT49701GEVATR	36-pin QFN package with exposed pad	Tape and reel, 1500 pieces per 7-inch reel

ABSOLUTE MAXIMUM RATINGS

Characteristic	Symbol	Notes	Rating	Units
Load Supply Voltage	V_{BB}		-0.5 to 18	V
Output Current	I_{OUT}	May be limited by duty cycle, ambient temperature, and heat sinking. Under any set of conditions, do not exceed the specified current rating or a Junction Temperature of 150°C.	1.0	A
Logic Input Voltage Range	V_{IN}		-0.3 to 7	V
SENSE _x Pin Voltage	V_{SENSEx}		0.5	V
		Pulsed $t_w < 1 \mu s$	2.5	V
VREF _x Pin Voltage	V_{REFx}		2.5	V
Operating Temperature Range	T_A	Range G	-40 to 105	°C
Junction Temperature	$T_J(max)$		150	°C
Storage Temperature Range	T_{stg}		-40 to 125	°C

THERMAL CHARACTERISTICS (may require derating at maximum conditions)

Characteristic	Symbol	Test Conditions	Min.	Units
Package Thermal Resistance	$R_{\theta JA}$	EV package, 4-layer PCB based on JEDEC standard	27	°C/W

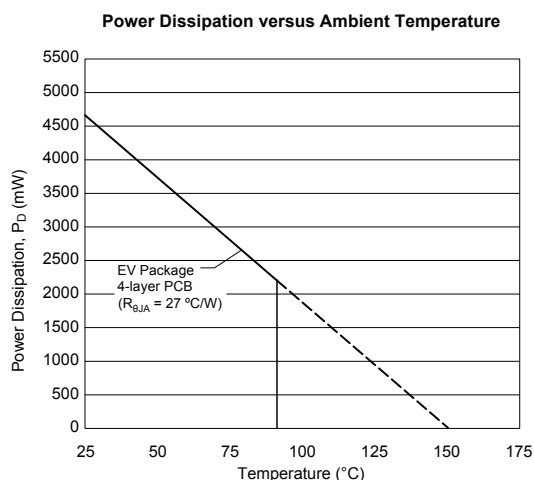

FUNCTIONAL BLOCK DIAGRAM

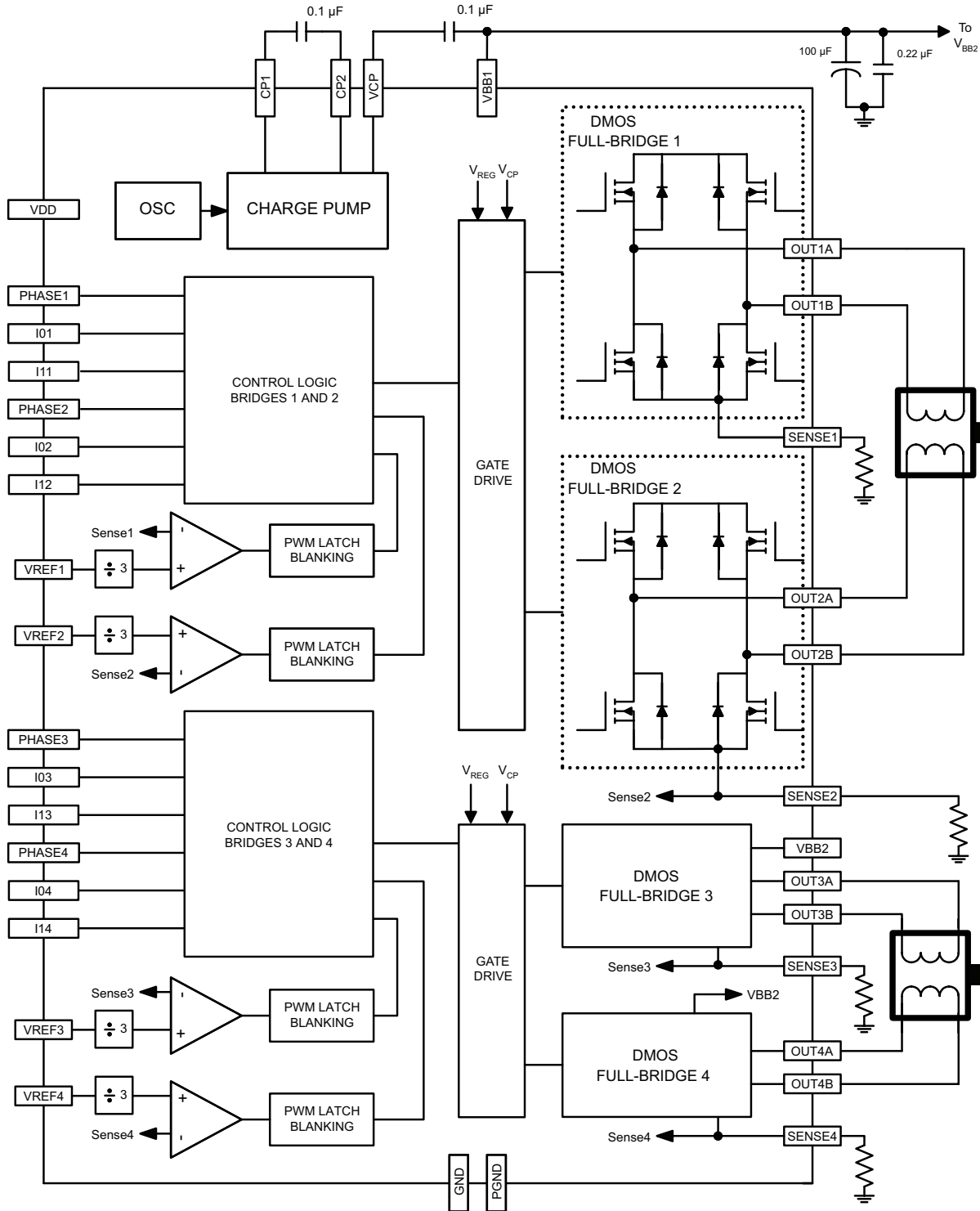

ELECTRICAL CHARACTERISTICS ^[1]: Valid at $T_A = 25^\circ\text{C}$, $V_{BB} = 18\text{ V}$, unless otherwise noted

Characteristics	Symbol	Test Conditions	Min.	Typ. ^[2]	Max.	Units
Load Supply Voltage Range	V_{BB}	Operating	4.0	–	18	V
Logic Supply Voltage Range	V_{DD}	Operating	3.0	–	5.5	V
Output On-Resistance	$R_{DS(on)}$	Source driver, $I_{OUT} = -1\text{ A}$, $T_J = 25^\circ\text{C}$	–	355	430	m Ω
		Sink driver, $I_{OUT} = 1\text{ A}$, $T_J = 25^\circ\text{C}$	–	355	430	m Ω
V_f , Outputs		$I_{OUT} = 1\text{ A}$	–	–	1.2	V
Output Leakage	I_{DSS}	Outputs, $V_{OUT} = 0$ to V_{BB}	–5	–	5	μA
VBB Supply Current	I_{BB}	$I_{OUT} = 0\text{ mA}$, outputs on, PWM = 50 kHz, DC = 50%	–	4.0	6.0	mA
		Outputs off	–	0.6	1.0	mA
VDD Supply Current	I_{DD}		–	5.5	8.0	mA
CONTROL LOGIC						
Logic Input Voltage	$V_{IN(1)}$		2	–	–	V
	$V_{IN(0)}$		–	–	0.8	V
Logic Input Current	I_{IN}	$V_{IN} = 0$ to 5 V	–5	<1	5	μA
Logic Input Hysteresis	V_{hys}		150	300	500	mV
Crossover Delay	t_{COD}		250	425	1000	ns
Blank Time	t_{BLANK}		0.7	1	1.3	μs
VREF _x Pin Input Voltage Range	V_{REFx}	Operating	0.0	–	1.5	V
VREF _x Pin Reference Input Current	I_{REF}	$V_{REF} = 1.5$	–	–	± 1	μA
Current Trip-Level Error ^[3]	V_{ERR}	$V_{REF} = 1.5$, phase current = 100%	–5	–	5	%
		$V_{REF} = 1.5$, phase current = 67%	–5	–	5	%
		$V_{REF} = 1.5$, phase current = 33%	–15	–	15	%
PROTECTION CIRCUITS						
VBB UVLO Threshold	$V_{UV(VBB)}$	V_{BB} rising	3.18	3.33	3.48	V
VBB Hysteresis	$V_{UV(VBB)hys}$		265	330	415	mV
VDD UVLO Threshold	$V_{UV(VDD)}$	V_{DD} rising	2.55	2.70	2.85	V
VDD Hysteresis	$V_{UV(VDD)hys}$		75	125	175	mV
Overcurrent Protection Threshold			1.8	–	–	A
Thermal Shutdown Temperature	T_{JTSD}		155	165	175	$^\circ\text{C}$
Thermal Shutdown Hysteresis	$T_{JTSDhys}$		–	15	–	$^\circ\text{C}$

^[1] For input and output current specifications, negative current is defined as coming out of (sourcing) the specified device pin.

^[2] Typical data are for initial design estimations only, and assume optimum manufacturing and application conditions. Performance may vary for individual units, within the specified maximum and minimum limits.

^[3] $V_{ERR} = [(V_{REF}/3) - V_{SENSE}] / (V_{REF}/3)$.

FUNCTIONAL DESCRIPTION

Device Operation. The AMT49701 is designed to operate two stepper motors, four DC motors, or one stepper and two DC motors. The currents in each of the output full-bridges, all N-channel DMOS, are regulated with fixed off-time pulse-width-modulated (PWM) control circuitry. Each full-bridge peak current is set by the value of an external current sense resistor, R_{Sx} , and a reference voltage, V_{REFx} .

Internal PWM Current Control. Each full-bridge is controlled by a fixed off-time PWM current control circuit that limits the load current to a desired value, I_{TRIP} . Initially, a diagonal pair of source and sink DMOS outputs are enabled, and current flows through the motor winding and R_{Sx} . When the voltage across the current sense resistor equals the voltage on the V_{REFx} pin, the current sense comparator resets the PWM latch, which turns off the source driver.

The maximum value of current limiting is set by the selection of R_S and voltage at the V_{REF} input with a transconductance function, approximated by:

$$I_{TripMax} = V_{REF} / (3 \times R_S)$$

Each current step is a percentage of the maximum current, $I_{TripMax}$. The actual current at each step I_{Trip} is approximated by:

$$I_{Trip} = (\% I_{TripMax} / 100) \times I_{TripMax}$$

where $\% I_{TripMax}$ is given in the Step Sequencing table.

Note: It is critical to ensure that the maximum rating of ± 500 mV on each $SENSEx$ pin is not exceeded.

Fixed Off-Time. The internal PWM current control circuitry uses a one-shot circuit to control the time the drivers remain off. The off-time (t_{off}) is 8.1 μs .

Blanking. This function blanks the output of the current sense comparator when the outputs are switched by the internal current control circuitry. The comparator output is blanked to prevent false detections of overcurrent conditions due to reverse recovery currents of the clamp diodes, or to switching transients related to the capacitance of the load. The stepper blank time, t_{BLANK} , is approximately 1 μs .

Control Logic. Communication is implemented via the industry standard I1, I0, and PHASE interface. This communication logic allows for full, half, and quarter step modes. Each bridge also has an independent V_{REF} input, so higher resolution step modes can be programmed by dynamically changing the voltage on the V_{REFx} pins.

Charge Pump (CP1 and CP2) The charge pump is used to generate a gate supply greater than V_{BB} to drive the source-side DMOS gates. A 0.1 μF ceramic capacitor should be connected between CP1 and CP2 for pumping purposes. A 0.1 μF ceramic capacitor is required between VCP and V_{BBx} to act as a reservoir to operate the high-side DMOS devices.

Shutdown. In the event of a fault (excessive junction temperature, or low voltage on VCP), the outputs of the device are disabled until the fault condition is removed. At power-up, the undervoltage lockout (UVLO) circuit disables the drivers.

Synchronous Rectification

When a PWM-off cycle is triggered by an internal fixed off-time cycle, load current will recirculate. The AMT49701 synchronous rectification feature will turn on the appropriate MOSFETs during the current decay, and effectively short out the body diodes with the low $R_{DS(on)}$ driver. This significantly lowers power dissipation. When a zero current level is detected, synchronous rectification is turned off to prevent reversal of the load current.

Mixed Decay Operation

The bridges operate in mixed decay mode. Referring to Figure 2, as the trip point is reached, the device goes into fast decay mode for 30.1% of the fixed off-time period. After this fast decay portion, t_{FD} , the device switches to slow decay mode for the

remainder of the off-time. During transitions from fast decay to slow decay, the drivers are forced off for approximately 600 ns. This feature is added to prevent shoot-through in the bridge. As shown in Figure 2, during this “dead time” portion, synchronous rectification is not active, and the device operates in fast decay and slow decay only.

Overcurrent Protection

An overcurrent monitor protects the AMT49701 from damage due to output shorts. If a short is detected, the AMT49701 latches the fault and disables the outputs. The latched fault can only be cleared by cycling the power to VBB. During OCP events, Absolute Maximum Ratings may be exceeded for a short period of time before outputs are latched off.

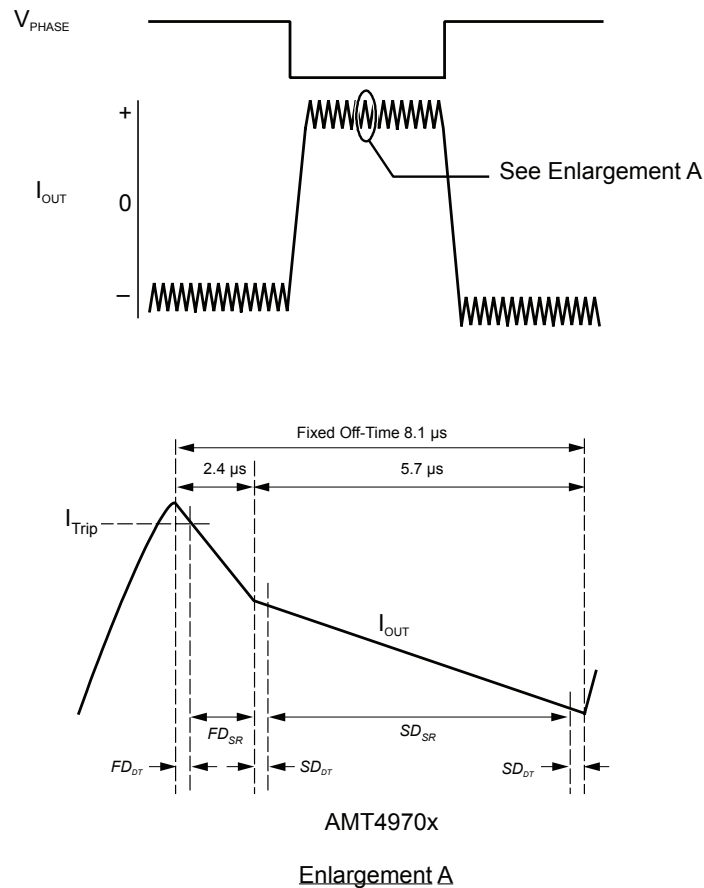

Figure 2: Mixed Decay Mode Operation

STEP SEQUENCING DIAGRAMS

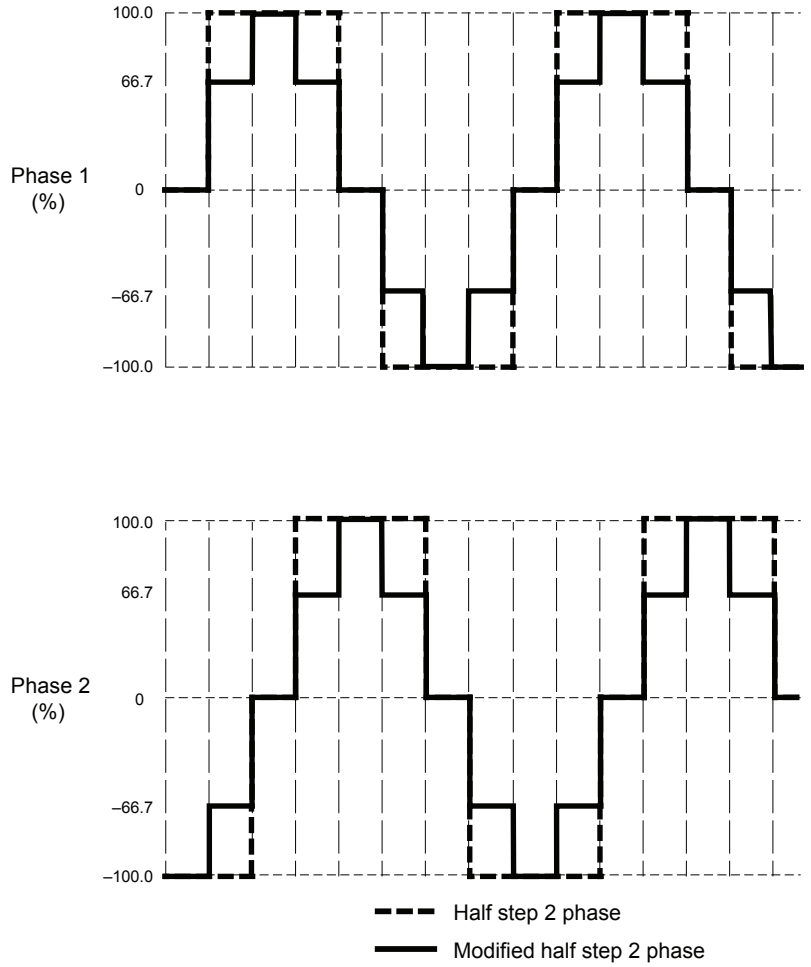
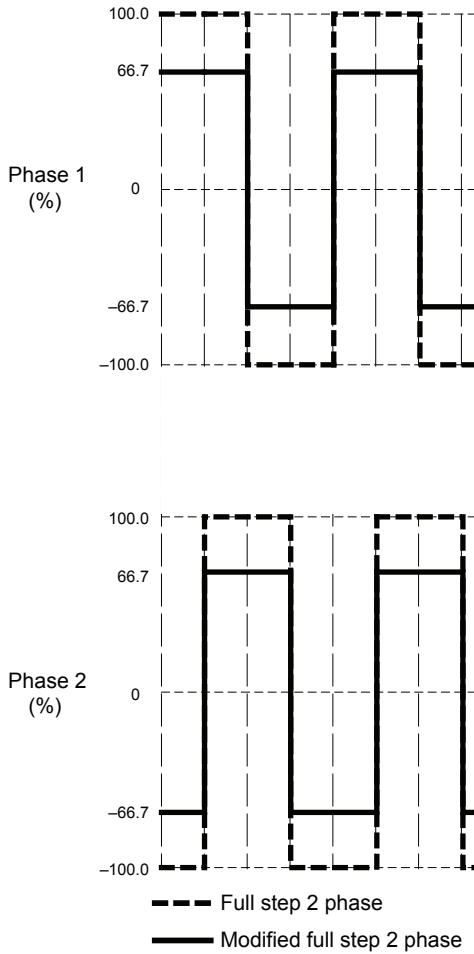

Figure 3: Step Sequencing for Full-Step Increments

Figure 4: Step Sequencing for Half-Step Increments

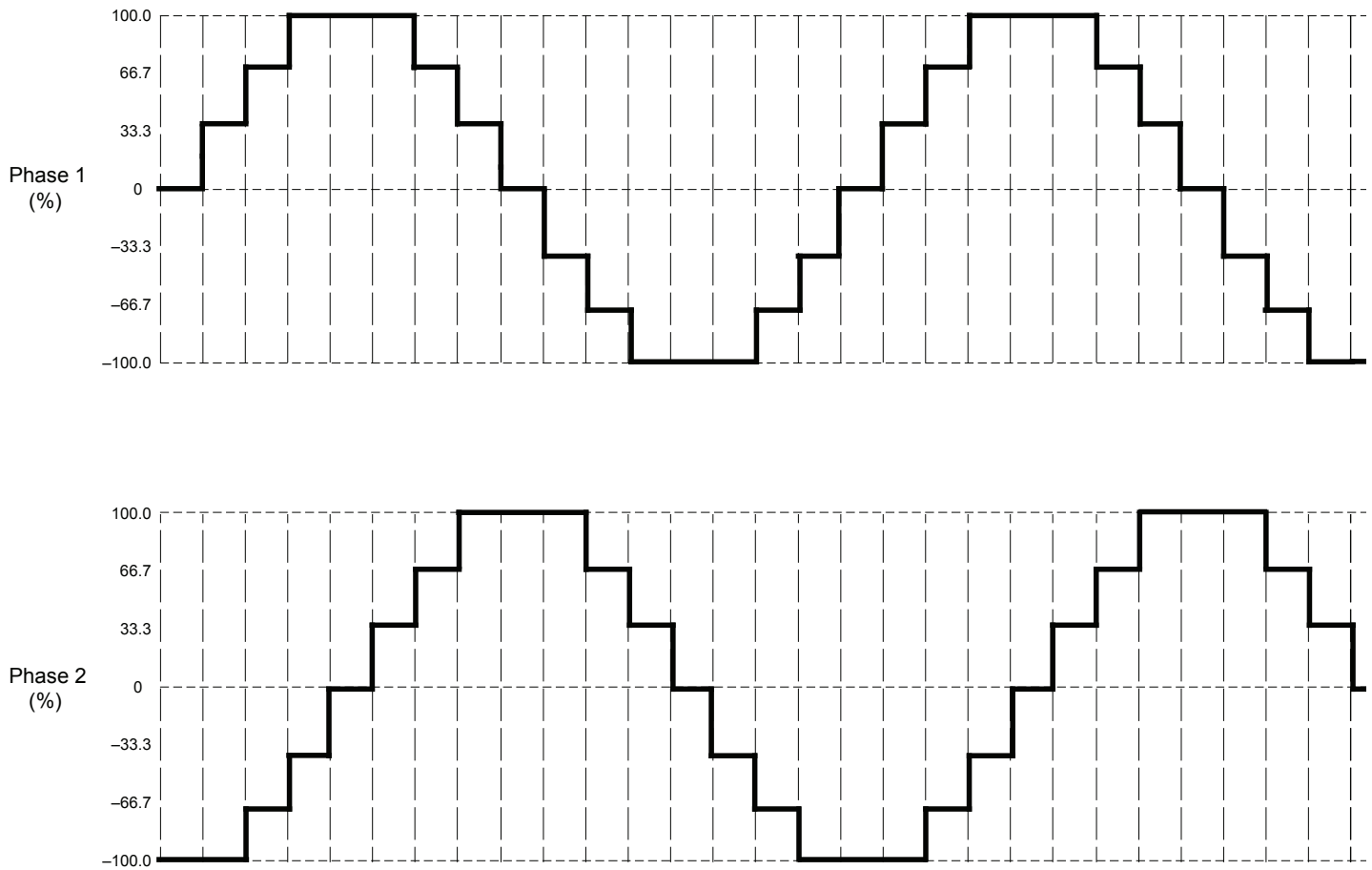

Figure 5: Step Sequence for Quarter-Step Increments

Table 1: Step Sequencing Settings

Full	1/2	1/4	Phase 1 (%I _{TripMax})	I0x	I1x	PHASE	Phase 2 (%I _{TripMax})	I0x	I1x	PHASE
	1	1	0	H	H	X	100	L	L	0
		2	33	L	H	1	100	L	L	0
1	2	3	100/66*	L/H*	L	1	100/66*	L/H*	L	0
		4	100	L	L	1	33	L	H	0
	3	5	100	L	L	1	0	H	H	X
		6	100	L	L	1	33	L	H	1
2	4	7	100/66*	L/H*	L	1	100/66*	L/H*	L	1
		8	33	L	H	1	100	L	L	1
	5	9	0	H	H	X	100	L	L	1
		10	33	L	H	0	100	L	L	1
3	6	11	100/66*	L/H*	L	0	100/66*	L/H*	L	1
		12	100	L	L	0	33	L	H	1
	7	13	100	L	L	0	0	H	H	X
		14	100	L	L	0	33	L	H	0
4	8	15	100/66*	L/H*	L	0	100/66*	L/H*	L	0
		16	33	L	H	0	100	L	L	0

*Denotes modified step mode

APPLICATIONS INFORMATION

DC Motor Control. Each of the 4 full bridges has independent PWM current control circuitry that makes the AMT49701 capable of driving up to four DC motors at currents up to 500 mA. Control of the DC motors is accomplished by tying the I0x and I1x pins together, creating an equivalent ENABLE function with maximum current defined by the voltage on the corresponding VREF pin. The DC motors can be driven via a PWM signal on this enable signal, or on the corresponding PHASE pin. Motor control includes forward, reverse, and coast.

Layout. The printed circuit board should use a heavy groundplane. For optimum electrical and thermal performance, the AMT49701 must be soldered directly onto the board. On the underside of the AMT49701 package is an exposed pad, which provides a path for enhanced thermal dissipation. The thermal pad should be soldered directly to an exposed surface on the PCB. Thermal vias are used to transfer heat to other layers of the PCB.

Grounding. In order to minimize the effects of ground bounce and offset issues, it is important to have a low-impedance single-point ground, known as a *star ground*, located very close to the device. By making the connection between the exposed thermal

pad and the groundplane directly under the AMT49701, that area becomes an ideal location for a star ground point.

A low-impedance ground will prevent ground bounce during high-current operation and ensure that the supply voltage remains stable at the input terminal. The recommended PCB layout shown in the diagram below illustrates how to create a star ground under the device to serve both as low-impedance ground point and thermal path.

The two input capacitors should be placed in parallel and as close to the device supply pins as possible. The ceramic capacitor should be closer to the pins than the bulk capacitor. This is necessary because the ceramic capacitor will be responsible for delivering the high-frequency current components.

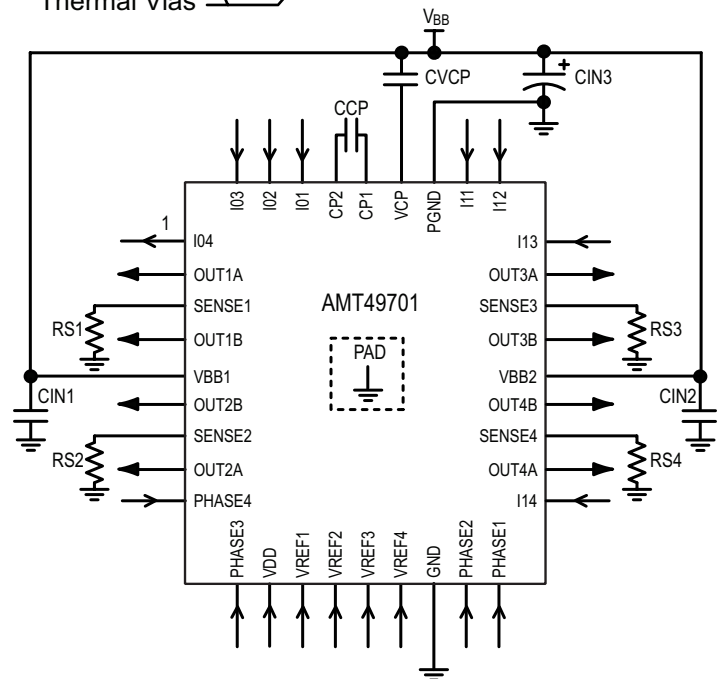
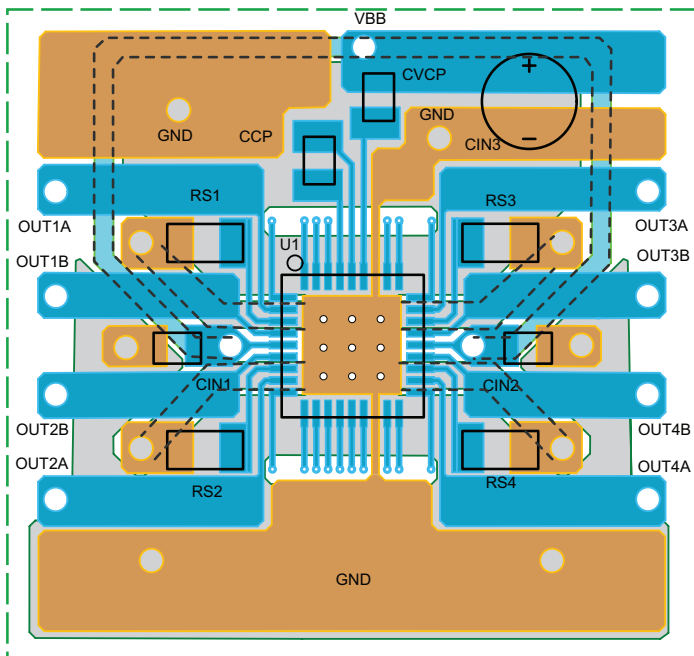
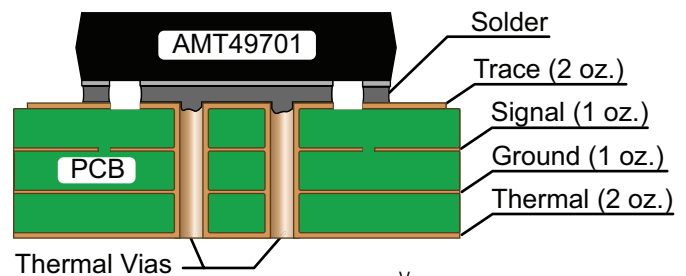
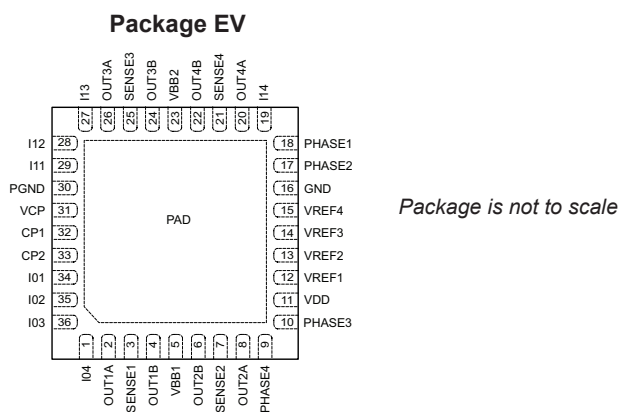

Figure 6: Printed circuit board layout with typical application circuit, shown at right. The copper area directly under the AMT49701 (U1) is soldered to the exposed thermal pad on the underside of the device. The thermal vias serve also as electrical vias, connecting it to the ground plane on the other side of the PCB, so the two copper areas together form the star ground.

Sense Pins. The sense resistors, RS_x , should have a very low impedance path to ground, because they must carry a large current while supporting very accurate voltage measurements by the current sense comparators. Long ground traces will cause additional voltage drops, adversely affecting the ability of the comparators to accurately measure the current in the windings. As shown in the layout in Figure 6, the $SENSE_x$ pins have very short traces to the RS_x resistors and very thick, low-impedance traces directly to the star ground beneath the device. If possible, there should be no other components on the sense circuits.

Note: When selecting a value for the sense resistors, be sure not to exceed the maximum voltage on the $SENSE_x$ pins of ± 500 mV.

PINOUT DIAGRAMS AND TERMINAL LIST TABLE



Terminal List Table

Number	Pin Name	Pin Description
2	OUT1A	DMOS Full-Bridge 1 Output A
3	SENSE1	Sense Resistor Terminal for Bridge 1
4	OUT1B	DMOS Full-Bridge 1 Output B
5	VBB1	Load Supply Voltage
6	OUT2B	DMOS Full-Bridge 2 Output B
7	SENSE2	Sense Resistor Terminal for Bridge 2
8	OUT2A	DMOS Full-Bridge 2 Output A
9	PHASE4	Control Input
10	PHASE3	Control Input
11	VDD	Logic Supply
12	VREF1	Analog Input
13	VREF2	Analog Input
14	VREF3	Analog Input
15	VREF4	Analog Input
16	GND*	Analog and Digital Ground
17	PHASE2	Control Input
18	PHASE1	Control Input
-	FAULTn	Open Drain Fault Output (JP package only)
19	I14	Control Input
20	OUT4A	DMOS Full-Bridge 4 Output A
21	SENSE4	Sense Resistor Terminal for Bridge 4
22	OUT4B	DMOS Full-Bridge 4 Output B
23	VBB2	Load Supply Voltage
24	OUT3B	DMOS Full-Bridge 3 Output B
25	SENSE3	Sense Resistor Terminal for Bridge 3
26	OUT3A	DMOS Full-Bridge 3 Output A
27	I13	Control Input
28	I12	Control Input
29	I11	Control Input
30	PGND*	Power Ground
31	VCP	Reservoir Capacitor Terminal
32	CP1	Charge Pump Capacitor Terminal
33	CP2	Charge Pump Capacitor Terminal
34	I01	Control Input
35	I02	Control Input
36	I03	Control Input
1	I04	Control Input
-	PAD	Exposed pad for enhanced thermal performance. Should be soldered to the PCB.

* GND, PGND, and thermal pad must be connected together externally under the device.

EV PACKAGE, 36-PIN QFN WITH EXPOSED THERMAL PAD

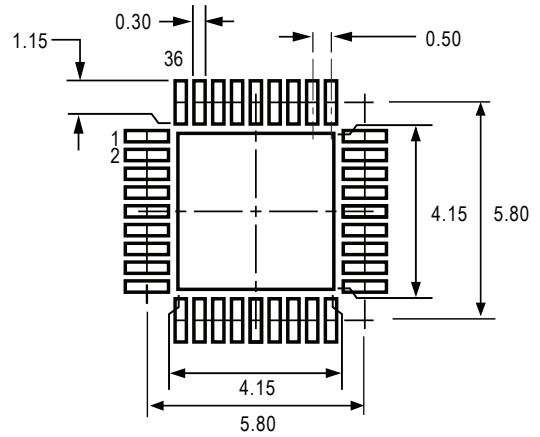
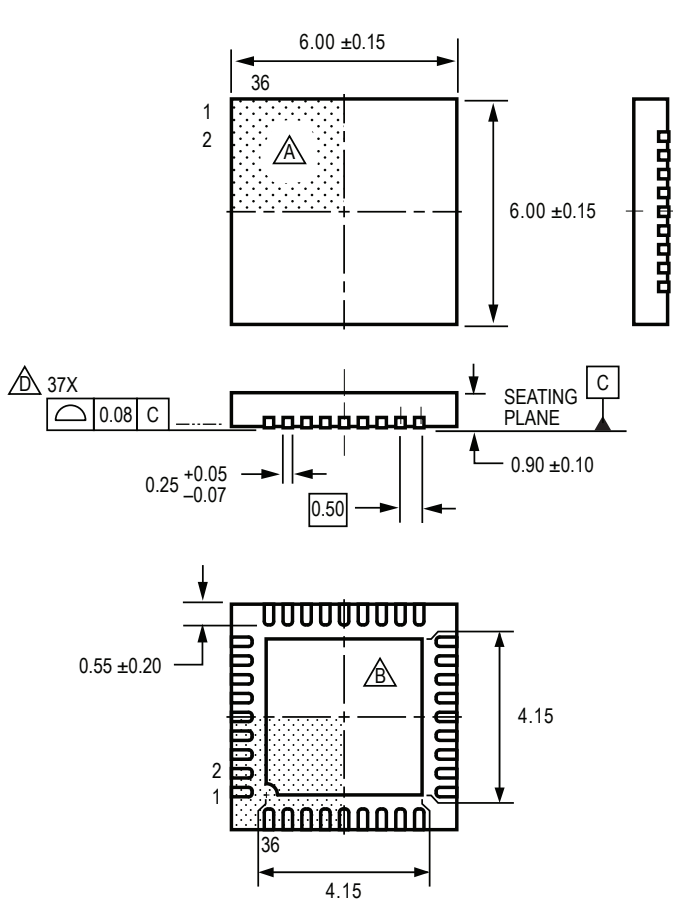

All dimensions nominal, not for tooling use
 (reference JEDEC MO-220VJJD-3, except pin count)
 Dimensions in millimeters
 Exact case and lead configuration at supplier discretion within limits shown

- Terminal #1 mark area
- Exposed thermal pad (reference only, terminal #1 identifier appearance at supplier discretion)
- Reference land pattern layout (reference IPC7351 QFN50P600X600X100-37V1M); All pads a minimum of 0.20 mm from all adjacent pads; adjust as necessary to meet application process requirements and PCB layout tolerances; when mounting on a multilayer PCB, thermal vias at the exposed thermal pad land can improve thermal dissipation (reference EIA/JEDEC Standard JESD51-5)
- Coplanarity includes exposed thermal pad and terminals

Revision History

Number	Date	Description
–	August 30, 2017	Initial release

Copyright ©2017, Allegro MicroSystems, LLC

Allegro MicroSystems, LLC reserves the right to make, from time to time, such departures from the detail specifications as may be required to permit improvements in the performance, reliability, or manufacturability of its products. Before placing an order, the user is cautioned to verify that the information being relied upon is current.

Allegro's products are not to be used in any devices or systems, including but not limited to life support devices or systems, in which a failure of Allegro's product can reasonably be expected to cause bodily harm.

The information included herein is believed to be accurate and reliable. However, Allegro MicroSystems, LLC assumes no responsibility for its use; nor for any infringement of patents or other rights of third parties which may result from its use.

For the latest version of this document, visit our website:

www.allegromicro.com

