



Chipsmall Limited consists of a professional team with an average of over 10 year of expertise in the distribution of electronic components. Based in Hongkong, we have already established firm and mutual-benefit business relationships with customers from,Europe,America and south Asia,supplying obsolete and hard-to-find components to meet their specific needs.

With the principle of “Quality Parts,Customers Priority,Honest Operation,and Considerate Service”,our business mainly focus on the distribution of electronic components. Line cards we deal with include Microchip,ALPS,ROHM,Xilinx,Pulse,ON,Everlight and Freescale. Main products comprise IC,Modules,Potentiometer,IC Socket,Relay,Connector.Our parts cover such applications as commercial,industrial, and automotives areas.

We are looking forward to setting up business relationship with you and hope to provide you with the best service and solution. Let us make a better world for our industry!



Contact us

Tel: +86-755-8981 8866 Fax: +86-755-8427 6832

Email & Skype: info@chipsmall.com Web: www.chipsmall.com

Address: A1208, Overseas Decoration Building, #122 Zhenhua RD., Futian, Shenzhen, China





Zentri AMW037 Data Sheet

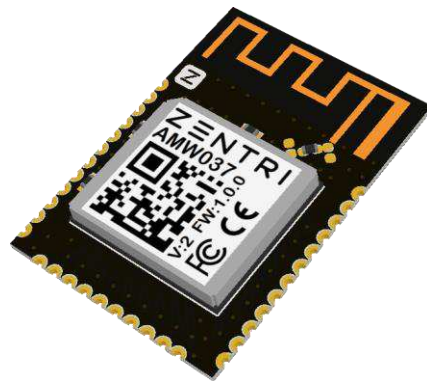

Disclaimer

While the information provided in this document is believed to be accurate, it is under development and Zentri reserves the right to make changes without further notice to the product described herein to improve reliability, function, or design, and makes no guarantee or warranty concerning the accuracy of said information, nor shall it be responsible for any loss or damage of whatever nature resulting from the use of, or reliance upon, such information. Zentri makes no warranties of any kind, whether express, implied or arising by custom or course of trade or performance, and specifically disclaims the implied warranties of title, non-infringement, merchantability, or fitness for a particular purpose.

No part of this document may be copied, reproduced, stored in a retrieval system, or transmitted, in any form or by any means, electronic, mechanical, photographic, or otherwise, or used as the basis for manufacture or sale of any items without the prior written consent of Zentri.

Trademarks

Zentri and the Zentri logo are trademarks of Zentri. Other trademarks in this document belong to their respective owners.

© 2014-2017 Zentri All rights reserved.

Document Number: ADS-MW037-101R

Release Date: August 29, 2017

Contact

<https://www.silabs.com/about-us/contact-us>

About this Data Sheet

This document provides information on the AMW037 802.11b/g/n Wi-Fi networking module from Zentri. Specifications for the module I/O, peripherals the WLAN subsystem were compiled from vendor datasheets and measured data.

Organization

This data sheet is organized into the following sections:

1	General Description.....	1
2	Block Diagram.....	2
3	Electrical Specifications	3
4	WLAN RF Specifications.....	6
5	Pinout and Signal Descriptions.....	8
6	Design Guidelines	11
7	Regulatory Certification	15
8	Packaging, Handling and Storage, RoHS.....	21
9	Ordering Information	24
10	Revision History & Glossary.....	25
11	References.....	26

AMW037 Data Sheet

Embedded Wi-Fi Networking Solution

General Features

- Self-contained ultra-low power Wi-Fi module with industry standard SSL/TLS secure TCP/IP network stack and PCB Trace antenna.
- Integrated SPI-serial flash for software upgrades and user accessible read/write file system

Wi-Fi

- Single band 2.4GHz IEEE 802.11b/g/n 1x1 Wi-Fi transceiver
- Includes support for all Wi-Fi security modes including Open, WEP, WPA, and WPA2-PSK

Microprocessor

- 32-bit application processor
- Operates up to 160MHz core frequency

Interfaces*

- UART: 1 x 4-wire, 1 x TX only up to 4.5Mbit/s
- GPIO: Up to 8 GPIOs (overlaid with peripherals)
- A/D converter: 1 x 10-bit resolution
- PWM: Up to 4 PWM outputs
- Wake-up: Wake pin for ultra-low power operation

**Some interfaces share module pins*

Operational & Radio

- Single operating voltage : 3.3V (typical)
- Operational Temperature Range: -40°C to +85°C
- Size : 16.5 x 24.8 x 2.6mm (0.65" x 0.98" x 0.10")
- Weight : 0.03 oz (1g)
- Current consumption @ 3.3V, 25°C
 - Standby : 0.9mA
 - Deep sleep / RTC : 20 / 60µA
 - Sleep (Memory Retention) : 0.31mA
 - Wi-Fi Powersave : 0.86mA (DTIM = 3)
 - Active receive : 65mA
 - Active transmit :
 - 100mA @ +0dBm
 - 200mA @ +18dBm
- Maximum RF transmit power
 - 802.11b/g : +20 dBm
 - 802.11n : +16 dBm
- Minimum Receive sensitivity
 - 802.11b/g : -93 dBm
 - 802.11n : -85 dBm

Applications

- Industrial, M2M and Home Automation
 - Environmental monitoring
 - Energy monitoring
 - Wireless sensing, remote data logging
 - HVAC, power, light, & thermostat control
 - Appliance control
- Security
 - Cameras, Doors/Window monitoring
 - Alarms, Smoke Detectors
 - Door and entry control
- Health & Fitness
 - Fitness Equipment
 - Home health monitoring e.g. weight scales
- Consumer
 - Audio, Toys, Robots

ZentriOS-WL Firmware Features

The ZentriOS-WL firmware supplied with the AMW037 provides a wide range of features beyond the underlying hardware, and supports application development via its command API.

For complete documentation of ZentriOS-WL, see:

<https://docs.zentri.com/zentrios/wl/latest/>

Software APIs

- [ZentriOS-WL command API](#)

Interfaces

- Serial (UART, remote terminal)
- SoftAP and WLAN client (not concurrent)

Servers

- TCP, UDP, HTTP, DHCP, DNS
- HTTP Server with RESTful API
- Fully customizable mobile responsive Web application with JavaScript and Python libraries

Clients

- TCP, TLS, NTP, DHCP, DNS
- HTTP(S) client
- Websocket client

Setup

- Multiple Wi-Fi setup options, including via serial command and Web setup with SoftAP

Peripherals and Sensors

- GPIOs for control, indication and monitoring
- Automated broadcast and streaming of sensor data
- Local caching of sensor data

Update and Recovery

Wireless OTA (Over-the-Air) update to remote manage firmware using the Zentri DMS (Device Management Service)

System Management

- System configuration and monitoring via setting and getting a wide range of variables
- Configurable power states
Sleep/wake timers

File System

- Read/write file system
- Storage of large files
- HTTP download to file system, HTTP upload from file system

Contents

1	General Description	1	7.3.2	Further Information.....	18
1.1	ZentriOS	1	7.5	Europe	19
2	Block Diagram	2	7.5.1	Labeling and User Information Requirements.....	19
3	Electrical Specifications.....	3	7.5.2	Further Information.....	19
3.1	Absolute Maximum Ratings.....	3	7.6	Australia.....	20
3.2	Recommended Operating Conditions	3	7.6.1	Further Information.....	20
3.2.1	DC Operating Conditions	3	7.7	New Zealand	20
3.2.2	Environmental Conditions	3	7.7.1	Further Information.....	20
3.3	Power Consumption	4	8	Packaging, Handling and Storage, RoHS	21
3.4	Digital IO Characteristics.....	5	8.1	Packaging.....	21
4	WLAN RF Specifications	6	8.2	Handling & Storage.....	21
4.1	Summary WLAN Specifications.....	6	8.3	RoHS Directive	21
4.2	WLAN Specifications.....	7	8.4	Tape and Reel Specifications	22
5	Pinout and Signal Descriptions	8	9	Ordering Information.....	24
5.1	Pinout.....	8	9.1	Ordering an Unspecified ZentriOS Version...24	
5.2	Pin Description.....	9	9.2	Ordering a Specific ZentriOS-WL Version or a Custom Firmware Version.....	24
6	Design Guidelines.....	11	9.3	ZentriOS Version History	24
6.1	Dimensions	11	10	Revision History & Glossary	25
6.3	Recommended PCB Footprint	12	10.1	Revision History	25
6.4	Routing Recommendations	12	10.2	Glossary	25
6.5	Soldering Information.....	13	11	References	26
6.6	Application Examples.....	14			
6.6.1	Operation using ZentriOS	14			
7	Regulatory Certification	15			
7.1	United States	15			
7.1.1	Labeling and User Information Requirements.....	15			
7.1.2	RF Exposure	16			
7.1.3	Further Information.....	16			
7.3	Canada	17			
7.3.1	Labeling and User Information Requirements.....	17			

1 General Description

The AMW037 module from Zentri provides an advanced stand-alone Wi-Fi and networking solution.

An integrated module avoids difficult RF layout and enables designers to rapidly embed Wi-Fi and secure networking functionality into virtually any device.

The ZentriOS embedded connected operating system, pre-programmed into all modules, may be used to fast-track module integration into end-products.

With dimensions of just 16.5mm x 23.5mm and a wide temperature range, the module is suitable for integration into most embedded applications.

The Wi-Fi device includes an integrated RF transmit power amplifier and provides superior Wi-Fi performance and full compatibility with all 2.4GHz 802.11b/g/n Wi-Fi networks.

The AMW037 microcontroller core operates at a frequency of 160MHz.

The AMW037 module offers extensive I/O and peripheral interfaces listed below, and provides additional interface combinations by leveraging multiplexing and alternate function capabilities.

- 1 x 4-Wire UART interface
- 8 x GPIOs
- 1 x 10-bit A/D converters
- 4 x PWM outputs
- 1 x ultra-low power wake input

The module is powered by a single 3.3V power supply.

Various powersave modes offer ultra-low power operation. Wake from low power sleep mode is possible using IO pins or the internal real-time clock, and wake from ultra-low power standby mode is achieved using the dedicated wake pin.

The module has numerous modular approvals. See Section 7, Regulatory Certification.

1.1 ZentriOS

This document is designed to cover the physical and electrical characteristics of the AMW037 module. For information on ZentriOS see:

<http://docs.zentri.com/zentrios/wl/latest/>

2 Block Diagram

Figure 1 is a block diagram of the AMW037 module. The main components of the module are a Wi-Fi System-on-Chip (SoC) and the quad-SPI serial flash. The processor and peripherals are driven by a 40MHz crystal. An on-board 2 MByte serial flash chip may be used to store user

applications, data and configuration, and firmware images as part of the Zentri secure over the air (OTA) update process.

Figure 1. AMW037 Architecture

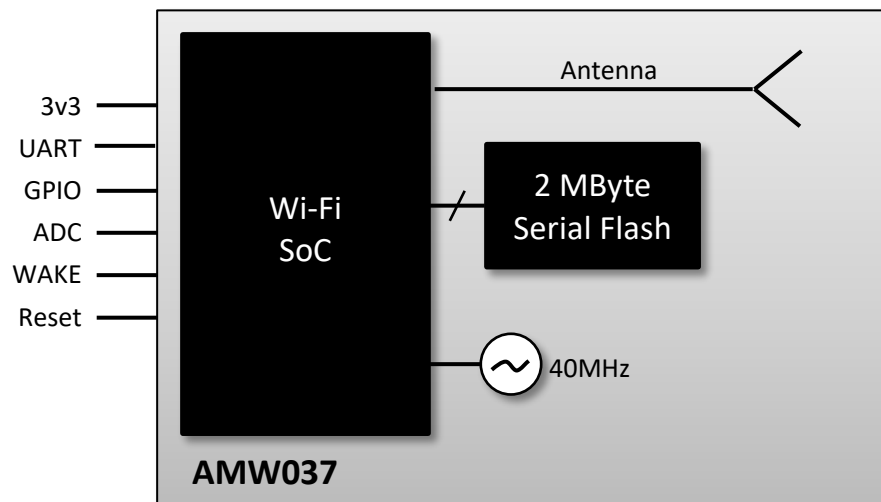

3 Electrical Specifications

3.1 Absolute Maximum Ratings

CAUTION! The absolute maximum ratings in Table 1 and Table 2 indicate levels where permanent damage to the device can occur, even if these limits are exceeded for only a brief duration. Functional operation is not guaranteed under these conditions. Operation at absolute maximum conditions for extended periods can adversely affect long-term reliability of the device.

Table 1. Absolute Maximum Voltage Ratings

Symbol	Ratings	Min	Max	Unit
VDD	External power supply voltage	-0.3	3.6	V
V _{in}	Input voltage on any other GPIO pin	GND - 0.3	VDD + 0.4	

Table 2. Absolute Maximum Environmental Ratings

Characteristic	Note	Min	Max	Unit
Storage Temperature	–	-40	+125	°C
Storage Humidity	Non-condensing (storage)	–	65	%
Electrostatic Discharge (HBM)	TEMP=25°C		2	kV
Electrostatic Discharge (CDM)	TEMP=25°C		0.5	kV
Maximum Soldering Temperature	IPC/JEDEC JSTD-020		260	°C

3.2 Recommended Operating Conditions

Functional operation is not guaranteed outside the limits shown in Table 3 and Table 4, and operation outside these limits for extended periods can adversely affect long-term reliability of the device.

3.2.1 DC Operating Conditions

Table 3. Recommended DC Operating Conditions

Symbol	Ratings	Min	Typ	Max	Unit
VDD ¹	External power supply voltage	3.0	3.3	3.6	V

Notes:

1. The performance of the Wi-Fi subsystem is degraded significantly at low voltages

3.2.2 Environmental Conditions

Table 4. Recommended Environmental Conditions

Characteristic	Note	Min	Max	Unit
Ambient Temperature	Limited by crystal specification	-30	+85	°C

Characteristic	Note	Min	Max	Unit
Relative Humidity	Non-condensing (operating)	–	85	%

Notes:

If you require an extended temperature range, contact Zentri.

3.3 Power Consumption

Table 5. Power consumption (VDD_3V3, VDD_WIFI, VBAT @ 3.3V)

Parameters	Min	Typical	Max	Unit
Transmit @ +18dBm		200		mA
Transmit @ +12dBm		150		mA
Transmit @ +0dBm		100		mA
Receive		50		mA
Application running, radio off		25		mA
Sleep		10		μA
Power up, 70ms boot time		15		mA

3.4 Digital IO Characteristics

All digital IO pads are bidirectional, non-inverting and tri-state. Each pad includes an input and an output buffer with tristate control inputs. When the AMW037 is powered down, all output enable signals can be set to hold high or low to minimize power consumption.

The hold functionality introduces some positive feedback into the pad. Hence, the external driver that drives the pad must be stronger than the positive feedback. The required drive strength is however small – in the range of 5uA.

Table 6. Digital IO Characteristics

Parameters	Min	Max	Unit
Input low voltage	-0.3	0.25 x VDD	V
Input high voltage	0.75 x VDD	3.6	V
Input leakage current		50	μA
Output low voltage		0.1 x VDD	V
Output high voltage	0.8 x VDD		V
Input pin capacitance		2	pF
Maximum drive capability		12	mA

4 WLAN RF Specifications

Unless otherwise stated, the specifications in this section apply when the operating conditions are within the limits specified in Section 3.2, Recommended Operating Conditions. Functional operation outside these limits is not guaranteed.

All specifications are measured by connecting directly to either of the antenna ports via a short PCB trace with the other antenna port terminated in 50 ohms.

4.1 Summary WLAN Specifications

Table 7. Summary WLAN Specifications

Feature Supported	Description
WLAN Standard	IEEE 802.11b/g/n 1x1 SISO
Frequency Band	2.412 GHz – 2.484 GHz
WLAN Channels	Channels 1 – 14
Data Rates	802.11b (1, 2, 5.5, 11 Mbps) 802.11g (6, 9, 12, 24, 36, 48, 54 Mbps) 802.11n (HT20 MCS0-MCS7)

4.2 WLAN Specifications

Table 8. WLAN Receiver Performance Specifications

Parameter	Condition/Notes	Min	Typical	Max	Unit
Frequency Range	–	2412	–	2484	MHz
Operating Temperature ¹	–	-40	–	+85	°C
Receive Sensitivity ² (8% PER for 1024 octet PSDU) at either antenna port	1 Mbps DSSS	–	-98	–	dBm
	11 Mbps CCK	–	-91	–	
Receive Sensitivity ² (10% PER for 1000 octet PSDU) at antenna port	6 Mbps OFDM	–	-93	–	dBm
	54 Mbps OFDM	–	-75	–	
Receive Sensitivity ² (10% PER for 4096 octet PSDU) at either antenna port.	6.5 Mbps MCS0, HT20	–	-85	–	dBm
	65 Mbps MCS7, HT20	–	-72	–	
Transmit power @ 72.2Mbps		14	15	16	dBm
Transmit power @ 1Mbps		18	19	20	dBm

Notes:

1. Operation below -20°C and above +65°C with parameter derating per Note 2
2. Derate receive sensitivity by 1.5dB for operation between temperatures of -40°C to -20°C and 65°C to 85°C

5 Pinout and Signal Descriptions

5.1 Pinout

A top view of the AMW037 pinout is depicted in Figure 2. All dimensions are in thousands of an inch. A recommended footprint is provided in Section 6.2.

Figure 2. AMW037 Pinout (TOP View – Pins NOT visible from top!)

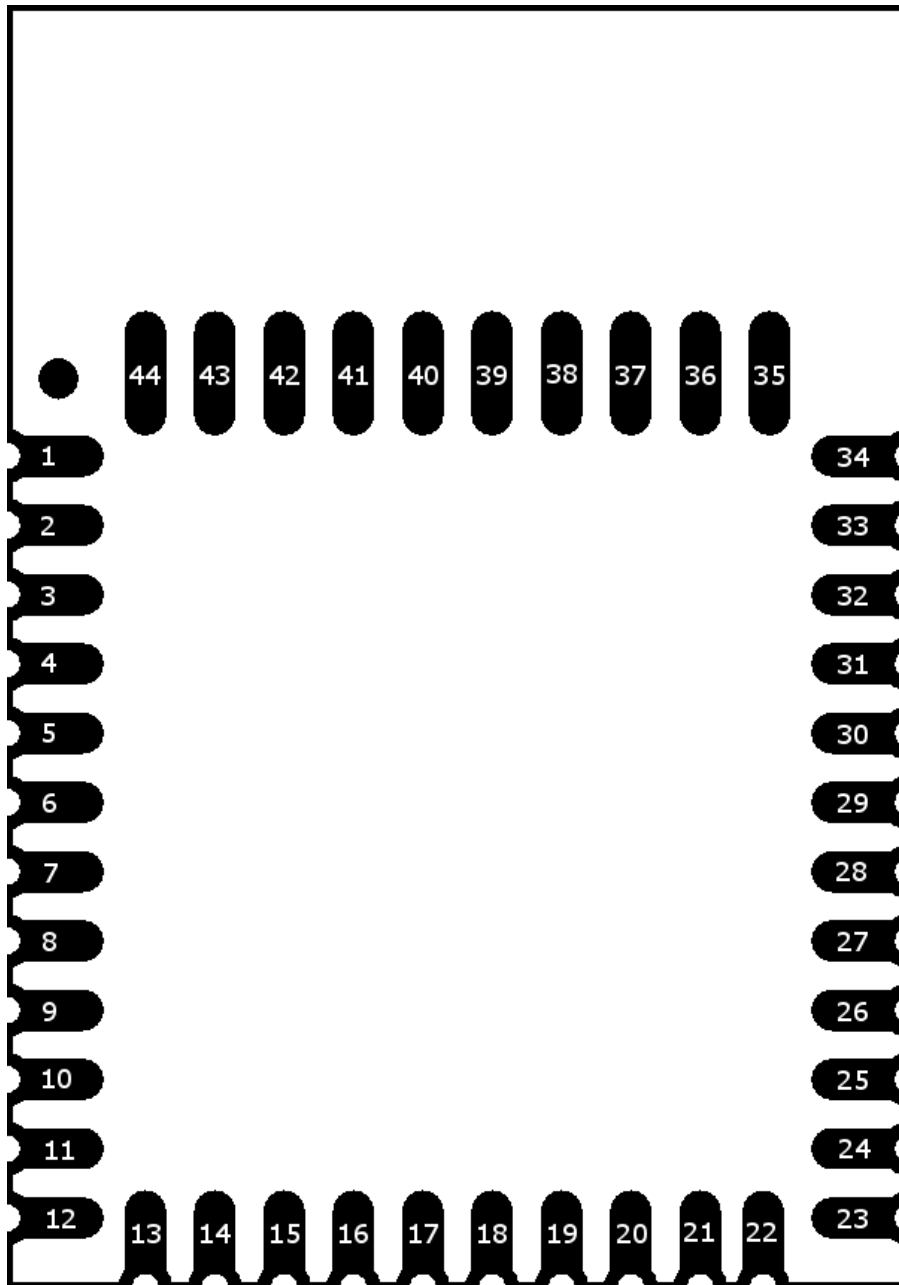

5.2 Pin Description

Table 9. AMW037 Pin Definitions

Pin	Name	Type ¹	Primary Function	Alternate & Other Function(s)
1	GND	S	Ground	-
2	VDD	S	Power Supply	+3.3V nominal
3	ADC	A	ADC	-
4-5	-	-	-	-
6	WAKE	O	WAKE	(1k resistor to RESET_N)
7	-	-	-	-
8	GPIO_0	I/O	GPIO / Factory Reset	PWM_0 (onboard 100k pull down)
9	GPIO_1	I/O	GPIO	PWM_1
10	UART_RX	I/O	-	-
11	UART_TX	I/O	-	Boot Control ³ (onboard 10k pull down resistor)
12	GND	S	Ground	-
13	GPIO_2	I/O	GPIO	Boot Control ³ DEBUG_UART_TX (onboard 2.2k pull up resistor)
14	GPIO_3	IO	GPIO	Boot Control ³ (onboard 2.2k pull up resistor)
15	GPIO_4	I/O	GPIO	PWM2

Pinout and Signal Descriptions, Section 5

Pin	Name	Type ¹	Primary Function	Alternate & Other Function(s)
16-22	-	NC	-	-
23	GND	S	Ground	-
24	GPIO_5	I/O	GPIO	-
25-28	-	NC	-	-
29	RESET_N	I	RESET	-
30	GPIO_6	I/O	GPIO	UART_CTS
31	GPIO_7	I/O	GPIO	UART_RTS
32	-	NC	-	-
33	CHIP_EN	I	Chip Enable	VDD = Enable module GND = Deep Sleep Mode (onboard 100k pull up)
34-44	GND	S	-	-

Notes:

1. I = Input, O = Output, S = Supply, A = Analog, NC = No Connection (Do not connect to ground)
2. The Wi-Fi Antenna pin is AC-coupled and has a nominal 50 ohms output impedance.
3. The Boot Control pins must be at the following levels immediately after a reset in order for the module to boot correctly: UART_TX = GND, GPIO_2 = VDD, GPIO_3 = VDD

6 Design Guidelines

6.1 Dimensions

Figure 3 - AMW037 Spectre Dimensions

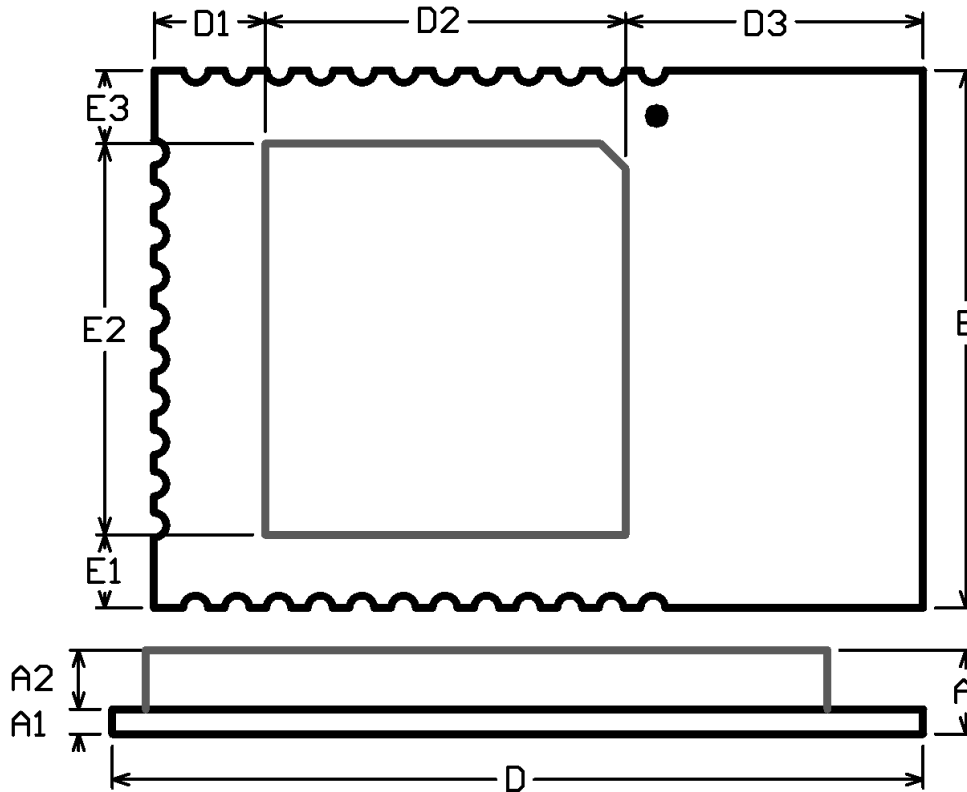

Figure 4 - AMW037 Spectre Dimensions

Symbol	Imperial (thou)	Tolerance (thou)	Metric (mm)	Tolerance (mm)
A	101	±6	2.57	±0.15
A1	30	±3	0.76	±0.08
A2	71	±6	1.80	±0.15
D	975	±5	24.77	±0.13
D1	133	±5	3.38	±0.13
D2	433	±6	11.00	±0.15
D3	358	±5	9.09	±0.13
E	650	±5	16.51	±0.13
E1	88	±5	2.24	±0.13
E2	472	±6	12.00	±0.15
E3	88	±5	2.24	±0.13

6.3 Recommended PCB Footprint

All dimensions in Figure 5 are in thousands of an inch unless otherwise marked.

Figure 5. AMW037 Recommended Footprint (Top)

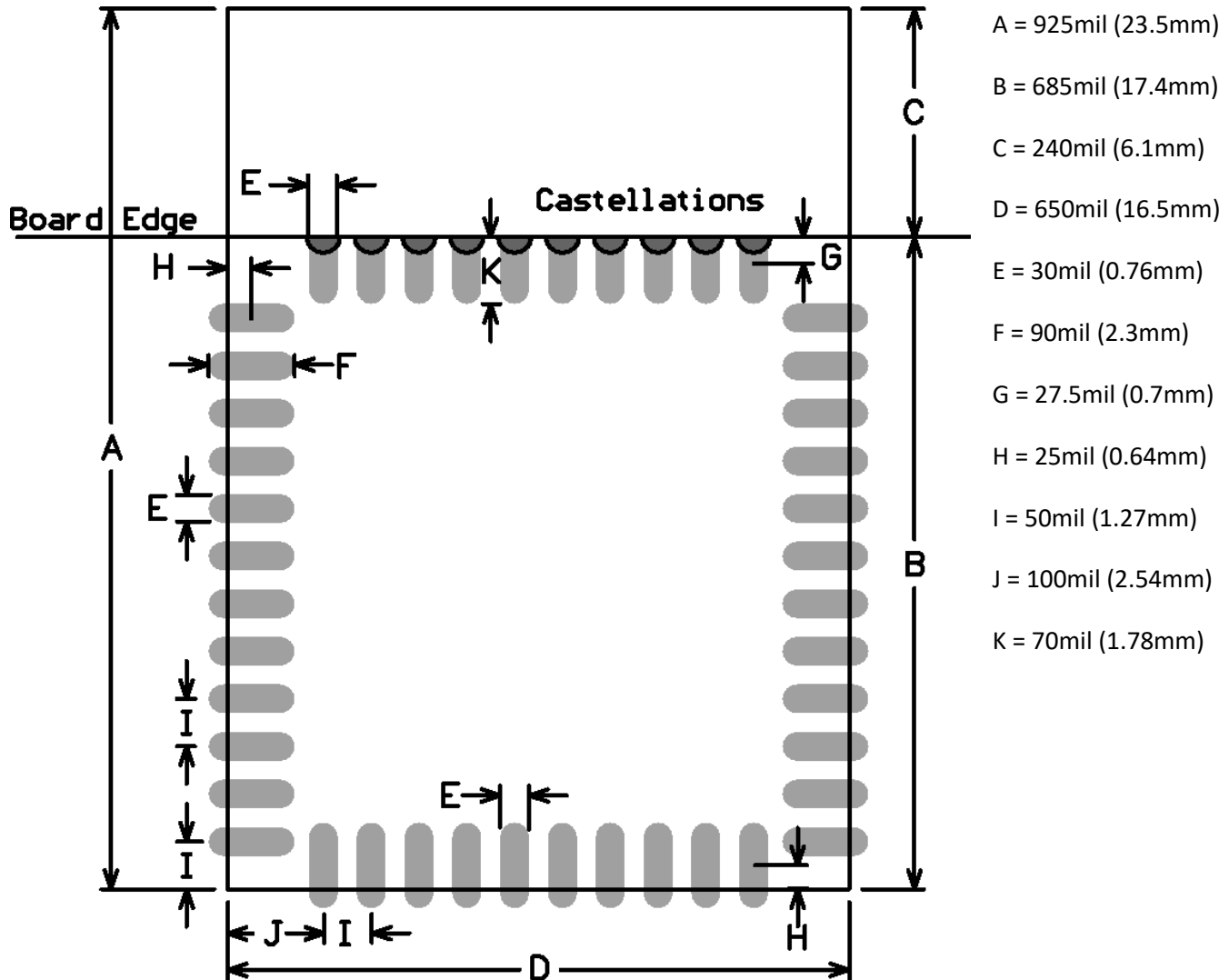

6.4 Routing Recommendations

When designing a carrier board, the addition of ground fill directly underneath the AMW037 module, rather than signal or power traces, is recommended. All ground pads adjacent to antenna pins must be connected to a solid ground plane. Failure to comply with these recommendations may result in degraded performance of WLAN functionality.

6.5 Soldering Information

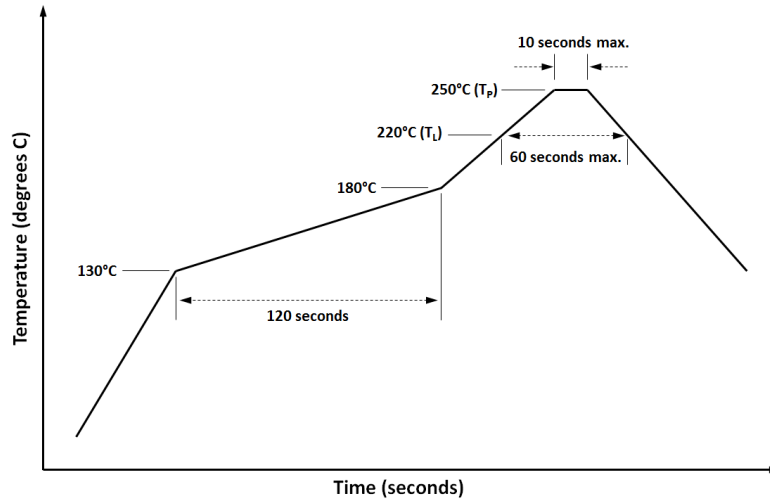

Figure 6 - Recommended solder reflow profile

Oven Name: HELLER

Process Window Name: ALPHA_OM325

Setpoints (摄氏度)									
Zone	1	2	3	4	5	6	7	8	9
Top	100	120	140	160	180	200	235	255	250
Bottom	100	120	140	160	180	200	235	255	250

Conveyor Speed (cm/min): 70.0

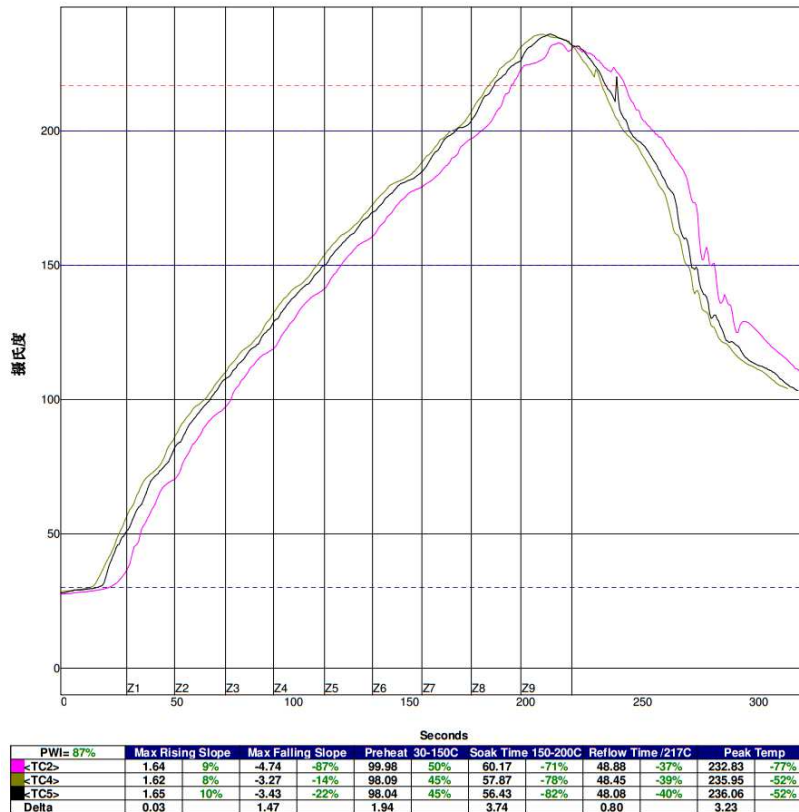

Figure 7 - Example solder reflow profile (AMW037-E03 evaluation board)

6.6 Application Examples

6.6.1 Operation using ZentriOS

Each AMW037 module is pre-installed with and licensed to use ZentriOS-WL, Zentri’s feature-rich and reliable Wi-Fi networking application. The module can be used with an external host microcontroller via the serial interface command API.

To use ZentriOS-WL with a host processor, the module only requires an external connection to power and a UART serial interface. A host processor connects to the UART (pins 10/11) as shown in Figure 8. Zentri recommends UART hardware flow control (RTS/CTS) is used to improve the reliability of data communications. All required pull up/down resistors are included inside the module.

For hardware design guidelines, see:

<https://docs.zentri.com/hardware/zentri/amwx06/amwx06-hardware-design#pcb-layout>

The general guidelines for the AMWx06 devices apply to all Zentri devices.

Figure 8. Using the AMW037 Module with ZentriOS and a UART serial interface

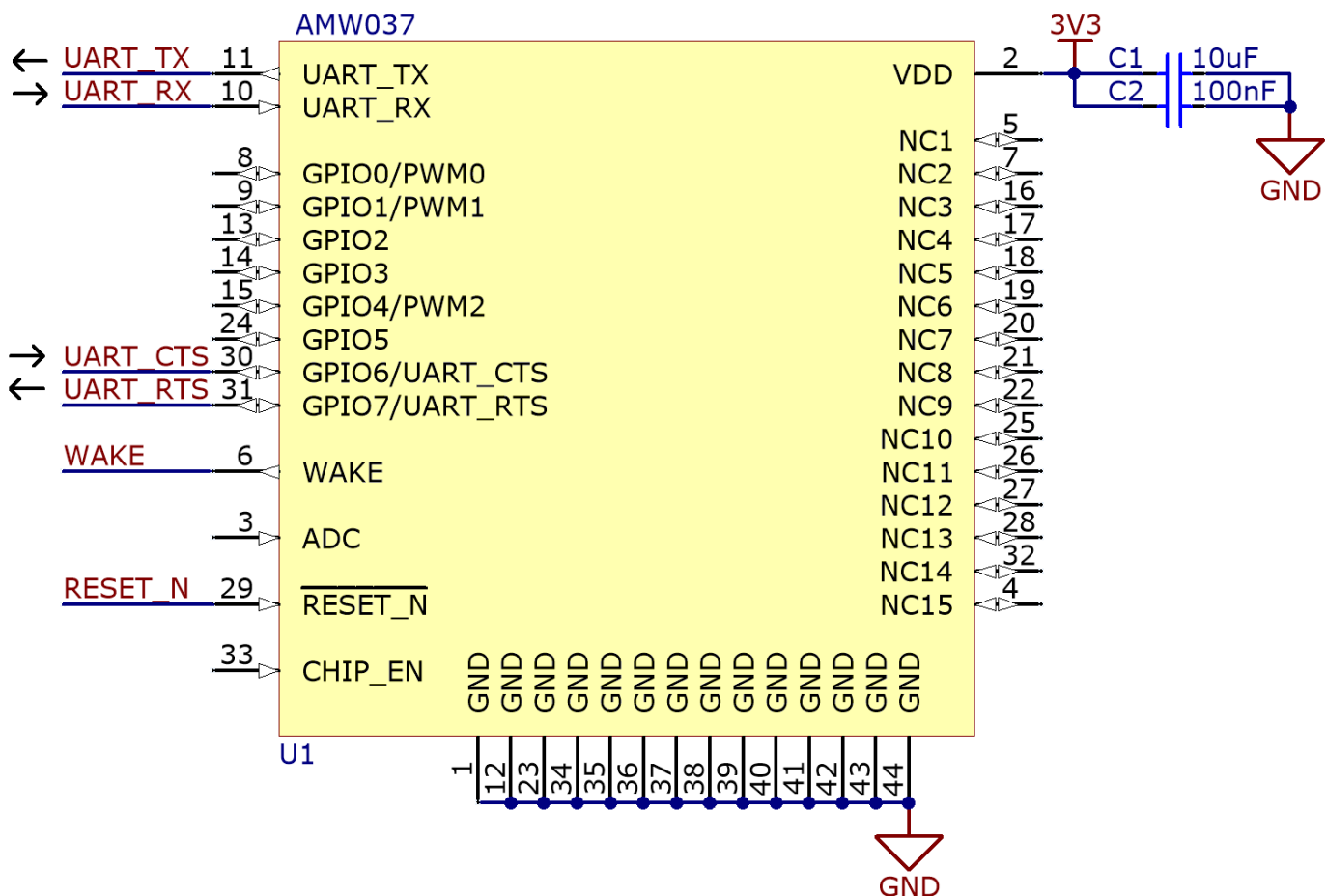

7 Regulatory Certification

The AMW037 module has been certified for operation in various regulatory domains. This section outlines certification information specific to the following countries and regions:

- United States
- Canada
- Europe
- Australia
- New Zealand

The certifications listed in this section are valid at the time of publication. For up-to-date information refer to Zentri documentation online at:

<https://docs.zentri.com>.

All AMW037 test reports are available on the Zentri website at:

<https://docs.zentri.com/zentri/docresources#amw037>

Should you require regulatory certification for the AMW037 module in a country or region not listed, please contact your local Zentri sales office or create a support request via our website at <https://www.silabs.com/about-us/contact-us>

7.1 United States

The Zentri AMW037 module has received Federal Communications Commission (FCC) CFR47 Telecommunications, Part 15 Sub-part C “Intentional Radiators” modular approval in accordance with Part 15.212 Modular Transmitter approval. Modular approval allows the end user to integrate the AMW037 module into a finished product without obtaining subsequent and separate FCC approvals for intentional radiation, provided no changes or modifications are made to the module circuitry. Changes or modifications could void the user’s authority to operate the equipment. The end user must comply with all of the instructions provided by the Grantee which indicate installation and/or operating conditions necessary for compliance.

The finished product is required to comply with all applicable FCC equipment authorization, regulations, requirements, and equipment functions not associated with the transmitter module portion. For example, compliance must be demonstrated to regulations for other transmit-

ter components within the host product; to requirements for unintentional radiators (Part 15 Sub-part B “Unintentional Radiators”), such as digital devices, computer peripherals, radio receivers, etc.; and to additional authorization requirements for non-transmitter functions on the transmitter module (i.e. Verification, or Declaration of Conformity) (e.g., transmitter modules may also contain digital logic functions) as appropriate.

7.1.1 Labeling and User Information Requirements

The AMW037 module has been labelled with a unique FCC ID number, and if the FCC ID is not visible when the module is installed inside another device, then the outside of the finished product into which the module is installed must also display a label referring to the enclosed module. This exterior label can use wording as follows:

Contains FCC ID: 2ABPY-5B9198
 This device complies with Part 15 of the FCC Rules.
 Operation is subject to the following two conditions:
 (1) this device may not cause harmful interference,
 and (2) this device must accept any interference received, including interference that may cause undesired operation.

If the exterior label area is smaller than the palm of the hand, the end product user manual must contain the above statement. The user manual should contain the following additional statement:

This equipment has been tested and found to comply with the limits for a Class B digital device, pursuant to part 15 of the FCC Rules. These limits are designed to provide reasonable protection against harmful interference in a residential installation. This equipment generates, uses and can radiate radio frequency energy and if not installed and used in accordance with the instructions, may cause harmful interference to radio communications. However, there is no guarantee that interference will not occur in a particular installation. If this equipment does cause harmful interference to radio or television reception, which can be determined by turning the equipment off and on, the user is encouraged to try to correct the interference by one or more of the following measures:

- Reorient or relocate the receiving antenna.
- Increase the separation between the equipment and receiver.
- Connect the equipment into an outlet on a circuit different from that to which the receiver is connected.
- Consult the dealer or an experienced radio/TV technician for help.

The Host Model Number (HMN) must be indicated at any location on the exterior of the end product or product packaging or product literature which shall be available with the end product or online.

Additional information on labeling and user information requirements for Part 15 devices can be found in KDB Publication 784748 available at the FCC Office of Engineering and Technology (OET) Laboratory Division Knowledge Database (KDB) at the following website: <http://www.fcc.gov>

For products available in the USA/Canada market, only channels 1 to 11 can be operated. Selection of other channels is not possible.

This module is intended for OEM integrators. The OEM integrator is responsible for compliance in all the rules that apply to the product into which this certified RF module is integrated.

Additional testing and certification may be necessary when multiple modules are used.

7.1.2 RF Exposure

All transmitters regulated by FCC must comply with RF exposure requirements. OET Bulletin 65, Evaluating Compliance with FCC Guidelines for Human Exposure to Radio Frequency Electromagnetic Fields, provides assistance in determining whether proposed or existing transmitting facilities, operations or devices comply with limits for human exposure to Radio Frequency (RF) fields adopted by the Federal Communications Commission (FCC). The bulletin offers guidelines and suggestions for evaluating compliance.

If appropriate, compliance with exposure guidelines for mobile and unlicensed devices can be accomplished by the use of warning labels and by providing users with information concerning minimum separation distances from transmitting structures and proper installation of antennas.

The following statement must be included as a CAUTION statement in manuals and OEM products to alert users of FCC RF exposure compliance:

To satisfy FCC RF Exposure requirements for mobile and base station transmission devices, a separation distance of 20 cm or more should be maintained between the antenna of this device and persons during operation. To ensure compliance, operation at closer than this distance is not recommended. The antenna(s) used for this transmitter must not be co-located or operating in conjunction with any other antenna or transmitter.

If the AMW037 module is used in a portable application (i.e., the antenna is less than 20 cm from persons during operation), the integrator is responsible for performing Specific Absorption Rate (SAR) testing in accordance with FCC rules 2.1091.

7.1.3 Further Information

Additional information regarding FCC certification and use of the AMW037 module in the United States is available from the following sources.

- Federal Communications Commission (FCC)
<http://www.fcc.gov>

7.3 Canada

The AMW037 module has been certified for use in Canada under Industry Canada (IC) Radio Standards Specification (RSS) RSS-210 and RSSGen. Modular approval permits the installation of a module in a host device without the need to recertify the device.

7.3.1 Labeling and User Information Requirements

Labeling Requirements for the Host Device (from Section 3.2.1, RSS-Gen, Issue 3, December 2010): The host device shall be properly labeled to identify the module within the host device.

The Industry Canada certification label of a module shall be clearly visible at all times when installed in the host device, otherwise the host device must be labeled to display the Industry Canada certification number of the module, preceded by the words “Contains transmitter module”, or the word “Contains”, or similar wording expressing the same meaning, as follows:

Contains transmitter module IC: 11685A-5B9198

The user documentation should contain the following information:

For products available in the USA/Canada market, only channel 1~11 can be operated. Selection of other channels is not possible.

Pour les produits disponibles aux États-Unis / Canada du marché, seul le canal 1 à 11 peuvent être exploités. Sélection d'autres canaux n'est pas possible.

The Host Model Number (HMN) must be indicated at any location on the exterior of the end product or product packaging or product literature which shall be available with the end product or online.

User Manual Notice for License-Exempt Radio Apparatus (from Section 7.1.3 RSS-Gen, Issue 3, December 2010): User manuals for license-exempt radio apparatus shall contain the following or equivalent notice in a conspicuous location in the user manual or alternatively on the device or both:

This device complies with Industry Canada license-exempt RSS standard(s). Operation is subject to the following two conditions: (1) this device may not cause interference, and (2) this device must accept any interference, including interference that may cause undesired operation of the device.

Le présent appareil est conforme aux CNR d'Industrie Canada applicables aux appareils radio exempts de licence. L'exploitation est autorisée aux deux conditions suivantes: (1) l'appareil ne doit pas produire de brouillage, et (2) l'utilisateur de l'appareil doit accepter tout brouillage radioélectrique subi, même si le brouillage est susceptible d'en compromettre le fonctionnement.

Transmitter Antenna Notification (from Section 7.1.2 RSS-Gen, Issue 3, December 2010): User manuals for transmitters shall display the following notice in a conspicuous location:

Under Industry Canada regulations, this radio transmitter may only operate using an antenna of a type and maximum (or lesser) gain approved for the transmitter by Industry Canada. To reduce potential radio interference to other users, the antenna type and its gain should be so chosen that the equivalent isotropically radiated power (EIRP) is not more than that necessary for successful communication.

Conformément à la réglementation d'Industrie Canada, le présent émetteur radio peut fonctionner avec une antenne d'un type et d'un gain maximal (ou inférieur) approuvé pour l'émetteur par Industrie Canada. Dans le but de réduire les risques de brouillage radioélectrique à l'intention des autres utilisateurs, il faut choisir le type d'antenne et son gain de sorte que la puissance isotrope rayonnée équivalente (p.i.r.e.) ne dépasse pas l'intensité nécessaire à l'établissement d'une communication satisfaisante.

The above notice may be affixed to the device instead of displayed in the user manual.

Regulatory Certification, Section 7

In the users manual of the end product, the end user has to be informed to keep at least 20 cm separation with the antenna while this end product is installed and operated. The end user has to be informed that the IC radio-frequency exposure guidelines for an uncontrolled environment can be satisfied.

The end user has to also be informed that any changes or modifications not expressly approved by the manufacturer could void the user's authority to operate this equipment.

User manuals for transmitters equipped with detachable antennas shall also contain the following notice in a conspicuous location:

This radio transmitter IC ID 11685A-5B9198 has been approved by Industry Canada to operate with the built-in antenna type, with the maximum permissible gain and required antenna impedance for each antenna type indicated. Antenna types not included in this list, having a gain greater than the maximum gain indicated for that type, are strictly prohibited for use with this device.

Le présent émetteur radio IC ID 11685A-5B9198 a été approuvé par Industrie Canada pour fonctionner avec l'antenne installé, et ayant un gain admissible maximal et l'impédance requise pour chaque type d'antenne.

Immediately following the above notice, the manufacturer shall provide a list of all antenna types approved for use with the transmitter, indicating the maximum permissible antenna gain (in dBi) and required impedance for each.

7.3.2 Further Information

Additional information may be obtained from the Industry Canada website at <http://www.ic.gc.ca>

7.5 Europe

The AMW037 module is a Radio Equipment Directive (RED) assessed radio module that is CE marked and has been manufactured and tested with the intention of being integrated into a final product.

The AMW037 module has been tested to Radio Equipment Directive (2014/53/EU) and R&TTE Directive (1999/5/EC).

Opinion has also been issued.

See [AMW0x7 CE Reports](#)

The R&TTE Compliance Association provides guidance on modular devices in the document titled Technical Guidance Note 01.

NOTE: To maintain conformance to the testing listed in Table 12. European Compliance Testing, the module shall be installed in accordance with the installation instructions in this data sheet and shall not be modified.

When integrating a radio module into a completed product the integrator becomes the manufacturer of the final product and is therefore responsible for demonstrating compliance of the final product with the essential requirements of the R&TTE Directive.

7.5.1 Labeling and User Information Requirements

The label on the final product which contains the AMW037 module must follow CE marking requirements. The R&TTE Compliance Association Technical Guidance Note 01 provides guidance on final product CE marking.

The end user manual or labelling should contain the following information:

This equipment complies with EU radiation exposure limits set forth for an uncontrolled environment. This equipment should be installed and operated with minimum distance 20cm between the radiator and your body.

7.5.2 Further Information

Further information may be obtained by searching for:

- European Conference of Postal and Telecommunications Administrations (CEPT)
- Radio Equipment Directive (RED), which replaces Radio and Telecommunications Terminal Equipment (R&TTE)

Table 12. European Compliance Testing

Certification	Standard	Report Number	Date	Laboratory
Safety	EN 60950-1:2006, A11:2009, A1:2010, A12:2011, A2:2013	L641926L244	20 July 2016	Sporton International Inc. Lab
EMF	EN 62311:2008	EA641926	26 May 2016	Sporton International Inc. Lab
EMC	EN 301 489-1 v2.1.1 (2016-11), Class B EN 301 489-17 v3.1.1 (2016-11)	21274927_001	10 July 2017	TÜV Rheinland
	EN 55022:2010/AC:2011, Class B EN 55024:2010	EH641926	26 May 2016	Sporton International Inc. Lab
Radio	EN 300 328 v2.1.1 (2016-11)	21274937_001	10 July 2017	TÜV Rheinland
Notified Body Opinion		G0M-1607-5753-C-V01	26 July 2016	Eurofins

7.6 Australia

Australian radio regulations do not provide a modular approval policy similar to the United States (FCC) or Canada (IC). However, AMW037 module test reports may be used in part to demonstrate compliance in accordance with ACMA Radio communications “Short Range Devices” Standard 2004 which references Australia/New Zealand industry standard AS/NZS-4268:2012. AMW037 RF transmitter test reports may be used as part of the product certification and compliance folder. For further information regarding the availability of RF test reports, please contact Zentri via our website at <https://www.silabs.com/about-us/contact-us>.

7.6.1 Further Information

Additional information may be obtained from the Australian Communications and Media Authority website at <http://www.acma.gov.au>.

7.7 New Zealand

New Zealand radio regulations do not provide a modular approval policy similar to the United States (FCC) or Canada (IC). However, AMW037 module test reports may be used in part to demonstrate compliance with the New Zealand “General User Radio License for Short Range Devices”. New Zealand Radio communications (Radio Standards) Notice 2010 references Australia/New Zealand industry standard AS/NZS-4268:2012. AMW037 RF transmitter test reports may be used as part of the product certification and compliance folder. For further information regarding the availability of RF test reports, please contact Zentri via our website at <https://www.silabs.com/about-us/contact-us>.

7.7.1 Further Information

Additional information may be obtained from the New Zealand Radio Spectrum Ministry of Economic Development website at <http://www.rsm.govt.nz>.