



Chipsmall Limited consists of a professional team with an average of over 10 year of expertise in the distribution of electronic components. Based in Hongkong, we have already established firm and mutual-benefit business relationships with customers from,Europe,America and south Asia,supplying obsolete and hard-to-find components to meet their specific needs.

With the principle of "Quality Parts,Customers Priority,Honest Operation,and Considerate Service",our business mainly focus on the distribution of electronic components. Line cards we deal with include Microchip,ALPS,ROHM,Xilinx,Pulse,ON,Everlight and Freescale. Main products comprise IC,Modules,Potentiometer,IC Socket,Relay,Connector.Our parts cover such applications as commercial,industrial, and automotives areas.

We are looking forward to setting up business relationship with you and hope to provide you with the best service and solution. Let us make a better world for our industry!



## Contact us

Tel: +86-755-8981 8866 Fax: +86-755-8427 6832

Email & Skype: info@chipsmall.com Web: www.chipsmall.com

Address: A1208, Overseas Decoration Building, #122 Zhenhua RD., Futian, Shenzhen, China



Ultra small, Single Band LNA-IC for 2.4 GHz Band Applications

FEATURES

- Low voltage operation +3.3 V typ.
- Low current consumption
  - 8.0 mA typ. (High-Gain mode)
  - 30 μA typ. (Low-Gain mode)
- High gain 17.0 dB typ. (High-Gain mode)
- Low noise figure 0.9 dB typ. (High-Gain mode)
- Low distortion +4.0 dBm typ. (High-Gain mode)
- 5 pin Wafer level chip size package (WLCSP)

DESCRIPTION

AN26024A is a single band LNA (Low Noise Amplifier)-IC for 2.4 GHz Band applications.

Realizing high performance by using 0.18 μm SiGeC Bi-CMOS process ( $f_T = 90$  GHz,  $f_{max} = 140$  GHz).

High/Low Gain-mode is changeable, controlled by integrated CMOS logic circuit.

Achieving miniaturization by using small size Wafer Level Chip Size Package (WLCSP).

APPLICATIONS

- WLAN/WiMAX

SIMPLIFIED APPLICATION

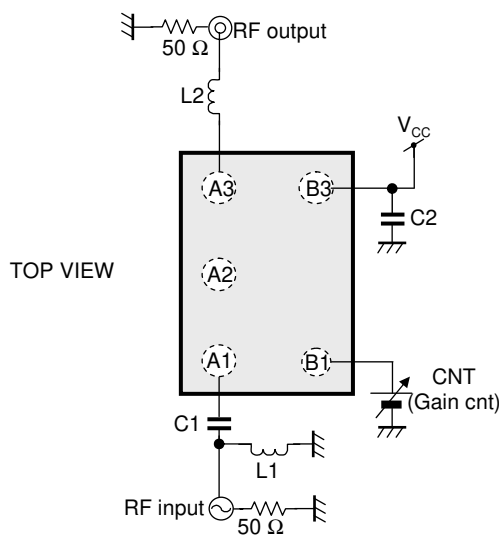

Components	Size	Value	Part Number	Vendor
L1	0603	5.1 nH	LQP03TN5N1H04	Murata
L2	0603	4.7 nH	LQP03TN4N7H04	Murata
C1	0603	1 000 pF	GRM033B11C102KD01	Murata
C2	0603	100 000 pF	GRM33B30J104KE18	Murata

Notes) This application circuit is an example. The operation of mass production set is not guaranteed. You should perform enough evaluation and verification on the design of mass production set. You are fully responsible for the incorporation of the above application circuit and information in the design of your equipment.

**ABSOLUTE MAXIMUM RATINGS**

Parameter	Symbol	Rating	Unit	Note
Supply voltage	$V_{CC}$	3.7	V	*1
Supply current	$I_{CC}$	18	mA	—
Operating ambient temperature	$T_{opr}$	-40 to +85	°C	*2
Operating junction temperature	$T_j$	-40 to +125	°C	*2
Storage temperature	$T_{stg}$	-55 to +125	°C	*2
Input Voltage Range	IN (Pin No.A1)	—	V	*3
	CNT (Pin No.B1)	-0.3 to $V_{CC}$	V	—
	OUT (Pin No.A3)	-0.3 to $V_{CC}$	V	—
ESD	HBM (Human Body Model)	2	kV	—

Notes). This product may sustain permanent damage if subjected to conditions higher than the above stated absolute maximum rating.

This rating is the maximum rating and device operating at this range is not guaranteeable as it is higher than our stated recommended operating range.

When subjected under the absolute maximum rating for a long time, the reliability of the product may be affected.

\*1:The values under the condition not exceeding the above absolute maximum ratings and the power dissipation.

\*2:Except for the operating ambient temperature, operating junction temperature and storage temperature, all ratings are for  $T_a = 25^{\circ}C$ .

\*3:RF signal input pin. Do not apply DC. Do not apply more than 0 dBm to RF input.

**POWER DISSIPATION RATING**

PACKAGE	$\theta_{JA}$	PD ( $T_a=25^{\circ}C$ )	PD ( $T_a=85^{\circ}C$ )
WLCSP	1391°C/W	0.072 W	0.029 W

Note). For the actual usage, please refer to the PD-Ta characteristics diagram in the package specification, supply voltage, load and ambient temperature conditions to ensure that there is enough margin follow the power and the thermal design does not exceed the allowable value.



**CAUTION**

Although this has limited built-in ESD protection circuit, but permanent damage may occur on it. Therefore, proper ESD precautions are recommended to avoid electrostatic damage to the MOS gates

**RECOMMENDED OPERATING CONDITIONS**

Parameter	Symbol	Min.	Typ.	Max.	Unit	Note
Supply voltage range	$V_{CC}$	3.0	3.3	3.6	V	*1

Note) \*1 : The values under the condition not exceeding the above absolute maximum ratings and the power dissipation.

**ELECTRICAL CHARACTERISTICS**

Note).  $T_a = 25^{\circ}\text{C} \pm 2^{\circ}\text{C}$ ,  
 $V_{CC} = 3.3\text{ V}$

Parameter	Symbol	Condition	Limits			Unit	Note
			Min	Typ	Max		
<b>DC electrical characteristics</b>							
Supply current HG	$I_{CCH}$	$V_{CC}$ current at High-Gain mode, No input signal	—	8	11	mA	—
Supply current LG	$I_{CCL}$	$V_{CC}$ current at Low-Gain mode, No input signal	—	30	90	$\mu\text{A}$	—
Input voltage (High-Gain mode)	$V_{IH}$	—	1.48	—	3.6	V	—
Input voltage (Low-Gain mode)	$V_{IL}$	—	0	—	0.6	V	—
SW current (High)	$I_{IH}$	Current at CNT pin $V_{IH} = V_{CC}$	—	30	45	$\mu\text{A}$	—

**ELECTRICAL CHARACTERISTICS (continued)**

Note).  $T_a = 25^{\circ}\text{C} \pm 2^{\circ}\text{C}$ ,  
 $V_{CC} = 3.3\text{ V}$ ,  
 $f_{RX} = 2.442\text{ GHz}$ ,  $PRX = -30\text{ dBm}$ , CW unless otherwise specified.

Parameter	Symbol	Condition	Limits			Unit	Note
			Min	Typ	Max		
<b>AC electrical characteristics</b>							
Power Gain HG	GHS	High-Gain mode	15.5	17.0	18.5	dB	—
Power Gain LG	GLS	Low-Gain mode $PRX = -20\text{ dBm}$	-9	-7	-5	dB	—
IIP3 -10 MHz offset HG	IIP3H1S	High-Gain mode $f_1 = f_{RX} - 10\text{ MHz}$ $f_2 = f_{RX} - 20\text{ MHz}$ Input 2 signals ( $f_1, f_2$ )	-1	4	—	dBm	—



**APPLICATION INFORMATION**

**REFERENCE VALUES FOR DESIGN**

Note).  $T_a = 25^{\circ}\text{C} \pm 2^{\circ}\text{C}$ ,

$V_{CC} = 3.3\text{ V}$ ,

$f_{RX} = 2.4\text{ GHz}, 2.442\text{ GHz}, 2.484\text{ GHz}$ ,  $PRX = -30\text{ dBm}$ , CW unless otherwise specified.

Parameter	Symbol	Condition	Reference values			Unit	Note
			Min	Typ	Max		
<b>AC electrical characteristics</b>							
Power Gain HG	GH	High-Gain mode	15.5	17	18.5	dB	*1
Power Gain LG	GL	Low-Gain mode PRX = -20 dBm	-9	-7	-5	dB	*1
Noise Figure HG	NFH	High-Gain mode	—	1.0	1.4	dB	*1,*2
Noise Figure LG	NFL	Low-Gain mode	—	7	9.5	dB	*1,*2
IIP3 -10 MHz offset HG	IIP3H1	High-Gain mode $f1 = f_{RX} - 10\text{ MHz}$ $f2 = f_{RX} - 20\text{ MHz}$ Input 2 signals ( $f1, f2$ )	-1	4	—	dBm	*1
IIP3 +10 MHz offset HG	IIP3H2	High-Gain mode $f1 = f_{RX} + 10\text{ MHz}$ $f2 = f_{RX} + 20\text{ MHz}$ Input 2 signals ( $f1, f2$ )	-1	4	—	dBm	*1
Input P1dB HG	IP1dBH	High-Gain mode	-20	-13	—	dBm	*1
IIP3 +100 kHz offset LG	IIP3L	Low-Gain mode $f1 = f_{RX}$ $f2 = f_{RX} + 100\text{ kHz}$ Input 2 signals ( $f1, f2$ )	10	24	—	dBm	*1
Input P1dB LG	IP1dB L	Low-Gain mode	0	8	—	dBm	*1
Reverse Isolation HG	ISOH	High-Gain mode	30	36	—	dB	*1
Reverse Isolation LG	ISOL	Low-Gain mode	5	7	—	dB	*1
Input Return Loss HG	S11H	High-Gain mode	8.5	14	—	dB	*1
Input Return Loss LG	S11L	Low-Gain mode	4	5	—	dB	*1
Output Return Loss HG	S22H	High-Gain mode	8.5	12	—	dB	*1
Output Return Loss LG	S22L	Low-Gain mode	6.5	10	—	dB	*1

Note) \*1 : Checked by design, not production tested.

\*2 : RF input Connector & substrate loss (0.09 dB) included.

**APPLICATION INFORMATION (continued)**

**REFERENCE VALUES FOR DESIGN (continued)**

Note).  $T_a = -40^{\circ}\text{C}$  to  $85^{\circ}\text{C}$ ,

$V_{CC} = 3.0$  to  $3.6\text{ V}$ ,

Parameter	Symbol	Condition	Reference values			Unit	Note
			Min	Typ	Max		
<b>DC electrical characteristics</b>							
Supply current HG	$I_{CCHT}$	$V_{CC}$ current at High-Gain mode No input signal	—	8	12.7	mA	*1
Supply current LG	$I_{CCLT}$	$V_{CC}$ current at Low-Gain mode No input signal	—	30	100	$\mu\text{A}$	*1
SW current (High)	$I_{IHT}$	Current at CNT pin $V_{IH} = V_{CC}$	—	30	51	$\mu\text{A}$	*1

Note) \*1 : Checked by design, not production tested.

**APPLICATION INFORMATION (continued)**

**REFERENCE VALUES FOR DESIGN (continued)**

Note).  $T_a = -40^{\circ}\text{C}$  to  $85^{\circ}\text{C}$ ,

$V_{CC} = 3.0$  to  $3.6\text{ V}$ ,

$f_{RX} = 2.4\text{ GHz}$ ,  $2.442\text{ GHz}$ ,  $2.484\text{ GHz}$ ,  $PRX = -30\text{ dBm}$ , CW unless otherwise specified

Parameter	Symbol	Condition	Reference values			Unit	Note
			Min	Typ	Max		
<b>AC electrical characteristics</b>							
Power Gain HG	GHTa	High-Gain mode	14.3	17	19.8	dB	*1
Power Gain LG	GLTa	Low-Gain mode PRX = -20 dBm	-9.8	-7	-4.5	dB	*1
Noise Figure HG	NFHTa	High-Gain mode	—	1.0	2.0	dB	*1,*2
Noise Figure LG	NFLTa	Low-Gain mode	—	7	10.2	dB	*1,*2
IIP3 -10 MHz offset HG	IIP3H1Ta	High-Gain mode f1 = $f_{RX} - 10\text{ MHz}$ f2 = $f_{RX} - 20\text{ MHz}$ Input 2 signals (f1, f2)	-2.3	4	—	dBm	*1
IIP3 +10 MHz offset HG	IIP3H2Ta	High-Gain mode f1 = $f_{RX} + 10\text{ MHz}$ f2 = $f_{RX} + 20\text{ MHz}$ Input 2 signals (f1, f2)	-2.3	4	—	dBm	*1
Input P1dB HG	P1dBHTa	High-Gain mode	-23.6	-13	—	dBm	*1

Note) \*1 : Checked by design, not production tested.

\*2 : RF input Connector & substrate loss (0.09 dB) included.

**PIN CONFIGURATION**

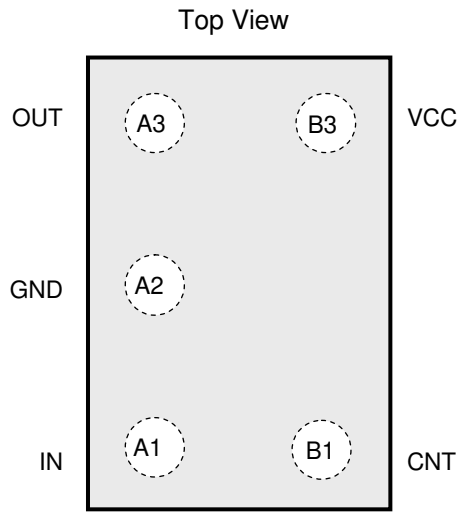

**PIN FUNCTIONS**

Pin No.	Pin name	Type	Description
A1	IN	Input	RF Input
A2	GND	Ground	GND
A3	OUT	Output	RF Output
B1	CNT	Input	High-Gain/Low-Gain switch L: Low-Gain Mode H: High-Gain Mode
B3	VCC	Power Supply	V <sub>CC</sub>

**FUNCTIONAL BLOCK DIAGRAM**

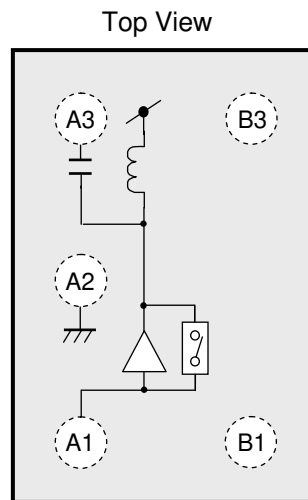

Notes) · This block diagram is for explaining functions. Part of the block diagram may be omitted, or it may be simplified.



PACKAGE INFORMATION ( Reference Data )

Package Code:ALGA005-W-0609ANA

Unit:mm

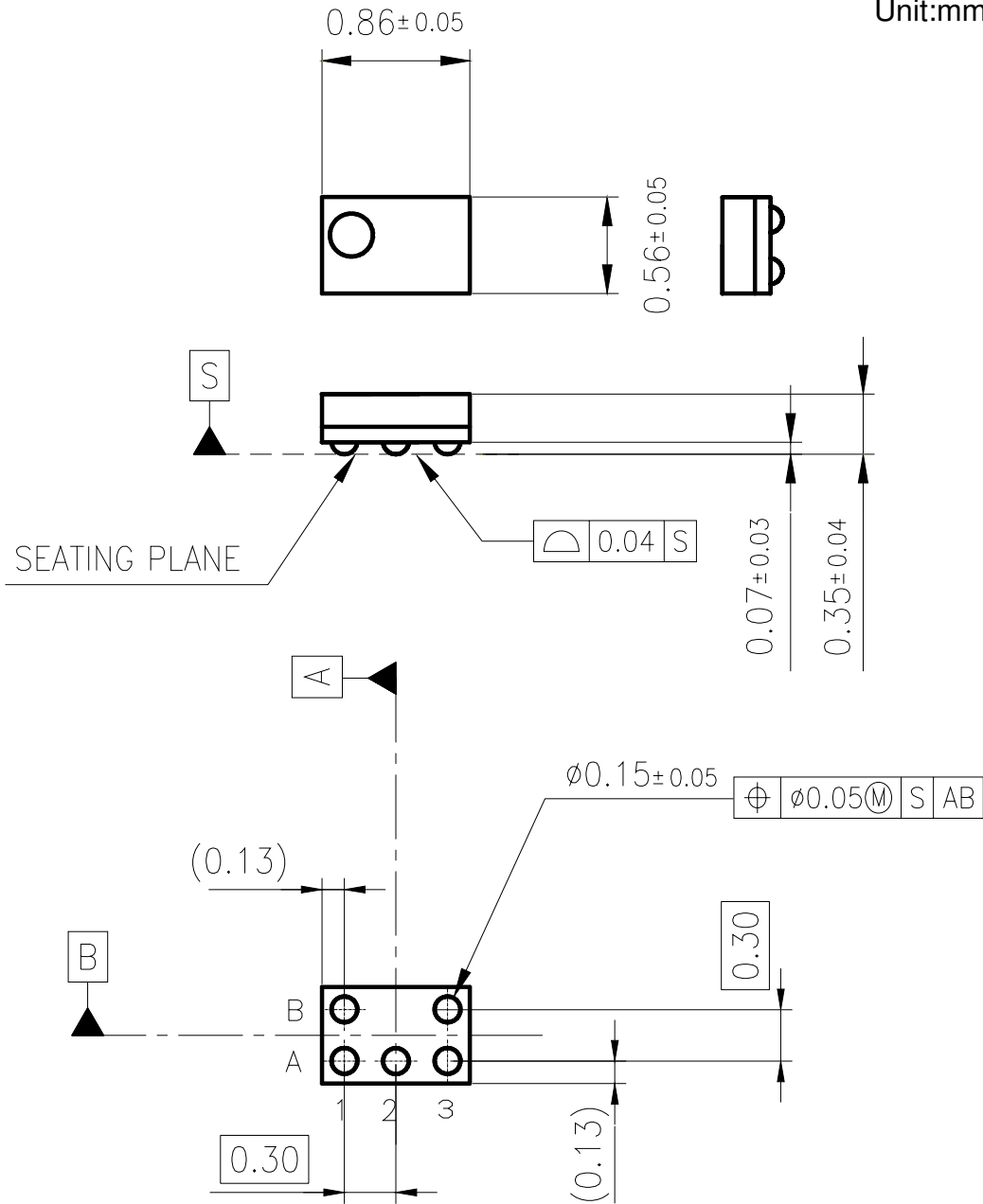

Body Material : Br/Sb Free Epoxy Resin
Reroute Material : Cu
Bump : SnAgCu

**IMPORTANT NOTICE**

1. The products and product specifications described in this book are subject to change without notice for modification and/or improvement. At the final stage of your design, purchasing, or use of the products, therefore, ask for the most up-to-date Product Standards in advance to make sure that the latest specifications satisfy your requirements.
  
2. When using the LSI for new models, verify the safety including the long-term reliability for each product.
  
3. When the application system is designed by using this LSI, be sure to confirm notes in this book.  
Be sure to read the notes to descriptions and the usage notes in the book
  
4. The technical information described in this book is intended only to show the main characteristics and application circuit examples of the products. No license is granted in and to any intellectual property right or other right owned by Panasonic Corporation or any other company. Therefore, no responsibility is assumed by our company as to the infringement upon any such right owned by any other company which may arise as a result of the use of technical information de-scribed in this book.
  
5. This book may be not reprinted or reproduced whether wholly or partially, without the prior written permission of our company.
  
6. This LSI is intended to be used for general electronic equipment [2.4 GHz Band Applications].  
Consult our sales staff in advance for information on the following applications: Special applications in which exceptional quality and reliability are required, or if the failure or malfunction of this LSI may directly jeopardize life or harm the human body.  
Any applications other than the standard applications intended.
  - (1) Space appliance (such as artificial satellite, and rocket)
  - (2) Traffic control equipment (such as for automobile, airplane, train, and ship)
  - (3) Medical equipment for life support
  - (4) Submarine transponder
  - (5) Control equipment for power plant
  - (6) Disaster prevention and security device
  - (7) Weapon
  - (8) Others : Applications of which reliability equivalent to (1) to (7) is required
 It is to be understood that our company shall not be held responsible for any damage incurred as a result of or in connection with your using the LSI described in this book for any special application, unless our company agrees to your using the LSI in this book for any special application.
  
7. This LSI is neither designed nor intended for use in automotive applications or environments unless the specific product is designated by our company as compliant with the ISO/TS 16949 requirements.  
Our company shall not be held responsible for any damage incurred by you or any third party as a result of or in connection with your using the LSI in automotive application, unless our company agrees to your using the LSI in this book for such application.
  
8. If any of the products or technical information described in this book is to be exported or provided to non-residents, the laws and regulations of the exporting country, especially, those with regard to security export control, must be observed.
  
9. Please use this product in compliance with all applicable laws and regulations that regulate the inclusion or use of controlled substances, including without limitation, the EU RoHS Directive. Our company shall not be held responsible for any damage incurred as a result of your using the LSI not complying with the applicable laws and regulations.

---

**USAGE NOTES**

1. When designing your equipment, comply with the range of absolute maximum rating and the guaranteed operating conditions (operating power supply voltage and operating environment etc.). Especially, please be careful not to exceed the range of absolute maximum rating on the transient state, such as power-on, power-off and mode-switching. Otherwise, we will not be liable for any defect which may arise later in your equipment.

Even when the products are used within the guaranteed values, take into the consideration of incidence of break down and failure mode, possible to occur to semiconductor products. Measures on the systems such as redundant design, arresting the spread of fire or preventing glitch are recommended in order to prevent physical injury, fire, social damages, for example, by using the products.

2. Comply with the instructions for use in order to prevent breakdown and characteristics change due to external factors (ESD, EOS, thermal stress and mechanical stress) at the time of handling, mounting or at customer's process. When using products for which damp-proof packing is required, satisfy the conditions, such as shelf life and the elapsed time since first opening the packages.
3. Pay attention to the direction of LSI. When mounting it in the wrong direction onto the PCB (printed-circuit-board), it might smoke or ignite.
4. Pay attention in the PCB (printed-circuit-board) pattern layout in order to prevent damage due to short circuit between pins. In addition, refer to the Pin Description for the pin configuration.
5. Perform a visual inspection on the PCB before applying power, otherwise damage might happen due to problems such as a solder-bridge between the pins of the semiconductor device. Also, perform a full technical verification on the assembly quality, because the same damage possibly can happen due to conductive substances, such as solder ball, that adhere to the LSI during transportation.
6. Take notice in the use of this product that it might break or occasionally smoke when an abnormal state occurs such as output pin-VCC short (Power supply fault), output pin-GND short (Ground fault), or output-to-output-pin short (load short) .  
  
And, safety measures such as an installation of fuses are recommended because the extent of the above-mentioned damage and smoke emission will depend on the current capability of the power supply.
7. Due to unshielded structure of this LSI, under exposure of light, function and characteristic of the product cannot be guaranteed. During normal operation or even under testing condition, please ensure that LSI is not exposed to light.
8. Basically, chip surface is ground potential. Please design to ensure no contact between chip surface and metal shielding.

## Request for your special attention and precautions in using the technical information and semiconductors described in this book

- (1) If any of the products or technical information described in this book is to be exported or provided to non-residents, the laws and regulations of the exporting country, especially, those with regard to security export control, must be observed.
- (2) The technical information described in this book is intended only to show the main characteristics and application circuit examples of the products. No license is granted in and to any intellectual property right or other right owned by Panasonic Corporation or any other company. Therefore, no responsibility is assumed by our company as to the infringement upon any such right owned by any other company which may arise as a result of the use of technical information described in this book.
- (3) The products described in this book are intended to be used for general applications (such as office equipment, communications equipment, measuring instruments and household appliances), or for specific applications as expressly stated in this book.  
Consult our sales staff in advance for information on the following applications:
  - Special applications (such as for airplanes, aerospace, automotive equipment, traffic signaling equipment, combustion equipment, life support systems and safety devices) in which exceptional quality and reliability are required, or if the failure or malfunction of the products may directly jeopardize life or harm the human body.It is to be understood that our company shall not be held responsible for any damage incurred as a result of or in connection with your using the products described in this book for any special application, unless our company agrees to your using the products in this book for any special application.
- (4) The products and product specifications described in this book are subject to change without notice for modification and/or improvement. At the final stage of your design, purchasing, or use of the products, therefore, ask for the most up-to-date Product Standards in advance to make sure that the latest specifications satisfy your requirements.
- (5) When designing your equipment, comply with the range of absolute maximum rating and the guaranteed operating conditions (operating power supply voltage and operating environment etc.). Especially, please be careful not to exceed the range of absolute maximum rating on the transient state, such as power-on, power-off and mode-switching. Otherwise, we will not be liable for any defect which may arise later in your equipment.  
Even when the products are used within the guaranteed values, take into the consideration of incidence of break down and failure mode, possible to occur to semiconductor products. Measures on the systems such as redundant design, arresting the spread of fire or preventing glitch are recommended in order to prevent physical injury, fire, social damages, for example, by using the products.
- (6) Comply with the instructions for use in order to prevent breakdown and characteristics change due to external factors (ESD, EOS, thermal stress and mechanical stress) at the time of handling, mounting or at customer's process. When using products for which damp-proof packing is required, satisfy the conditions, such as shelf life and the elapsed time since first opening the packages.
- (7) This book may be not reprinted or reproduced whether wholly or partially, without the prior written permission of our company.