



Chipsmall Limited consists of a professional team with an average of over 10 year of expertise in the distribution of electronic components. Based in Hongkong, we have already established firm and mutual-benefit business relationships with customers from,Europe,America and south Asia,supplying obsolete and hard-to-find components to meet their specific needs.

With the principle of “Quality Parts,Customers Priority,Honest Operation,and Considerate Service”,our business mainly focus on the distribution of electronic components. Line cards we deal with include Microchip,ALPS,ROHM,Xilinx,Pulse,ON,Everlight and Freescale. Main products comprise IC,Modules,Potentiometer,IC Socket,Relay,Connector.Our parts cover such applications as commercial,industrial, and automotives areas.

We are looking forward to setting up business relationship with you and hope to provide you with the best service and solution. Let us make a better world for our industry!



Contact us

Tel: +86-755-8981 8866 Fax: +86-755-8427 6832

Email & Skype: info@chipsmall.com Web: www.chipsmall.com

Address: A1208, Overseas Decoration Building, #122 Zhenhua RD., Futian, Shenzhen, China



DATA SHEET

Part No.	AN30235A
Package Code No.	UBGA036-W-3132AEL

Contents

■ Overview	3
■ Features	3
■ Applications	3
■ Package	3
■ Structure	3
■ Application Circuit Example	4
■ Block Diagram	5
■ Pin Layout	6
■ Pin Descriptions	7
■ Absolute Maximum Ratings	8
■ Operating Supply Voltage Range	8
■ Allowable Current and Voltage Ranges	9
■ Electrical Characteristics	10
■ Electrical Characteristics (Reference Values for Design)	13
■ Technical Data	16
1. Specifications of power supply block	16
2. Timing chart	17
3. I/O block circuit diagrams and pin function descriptions	24
4. P_D — T_a diagram	29
■ Usage Notes.....	30

AN30235A

2-Channel Step-up/down DC-DC Converter

■ Overview

AN30235A is a 2-channel step-up/down DC-DC converter with fixed switching frequency.

With one inductor for each channel, it can stably supply step-up/down voltages from two lithium-ion cells.

It has built-in N-channel MOSFET of low on resistance, allowing high efficient operation with fewer external components.

■ Features

- Wide range of input voltage (4.0 V to 8.4 V)
- 2-channel step-up/down DC-DC converter
 - DDCA: 4.5 V to 6.0 V / 850 mA
 - DDCB: 4.8 V / 1250 mA to 7.0 V / 800 mA
- High-accuracy feedback voltage ($\pm 2\%$)
- Synchronous rectifying system
- Bootstrap circuit
- Phase compensation
- Forced CCM (Continuous Conduction Mode)
- 1-MHz fixed switching frequency
- Digital soft start (5 ms)
- Shutdown function
- Short circuit protection with timer latch
- Power OK function

■ Applications

- Digital single lens reflex camera

■ Package

- 36-pin wafer level chip size package (WLCSP)
Size: 3.16 mm \times 3.06 mm (0.5 mm pitch)

■ Structure

- Bi-CMOS IC

■ Application Circuit Example

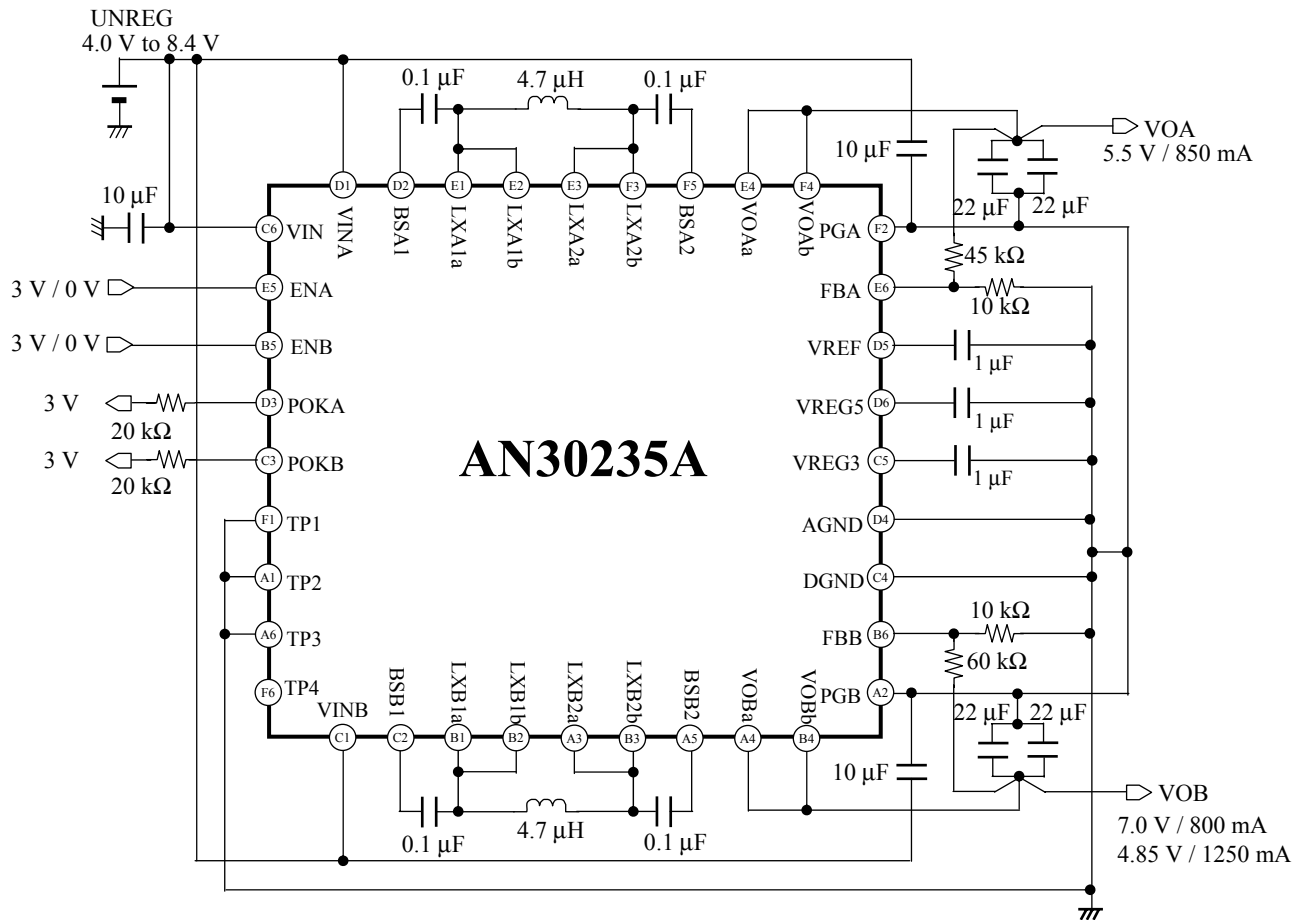

- Notes) • This application circuit is an example. Operation of mass production set is not guaranteed. Perform enough evaluation and verification on the design of mass production set.
- In case of not using CHB block, set up following pins as mentioned below. Otherwise, failures like malfunction or others might occur.
 Left open: Pin A3 (LXB2a), Pin A5 (BSB2), Pin B1 (LXB1a), Pin B2 (LXB1b), Pin B3 (LXB2b), Pin C2 (BSB1) and Pin C3 (POKB)
 Connected to GND: Pin A4 (VOBa), Pin B4 (VOBb), Pin B5 (ENB) and Pin B6 (FBB)
 Connected to Pin C6 (VIN): Pin C1 (VINB)
 - In case of not using CHA block, set up following pins except Pin C3 (POKB), TBD, as mentioned below. Otherwise, failures like malfunction or others might occur.
 Left open: Pin D2 (BSA1), Pin E1 (LXA1a), Pin E2 (LXA1b), Pin E3 (LXA2a), Pin F3 (LXA2b), Pin F5 (BSA2) and Pin D3 (POKA)
 Connected to GND: Pin E4 (VOAa), Pin E5 (ENA), Pin E6 (FBA) and Pin F4 (VOAb)
 Connected to Pin C6 (VIN): Pin D1 (VINA)

■ Block Diagram

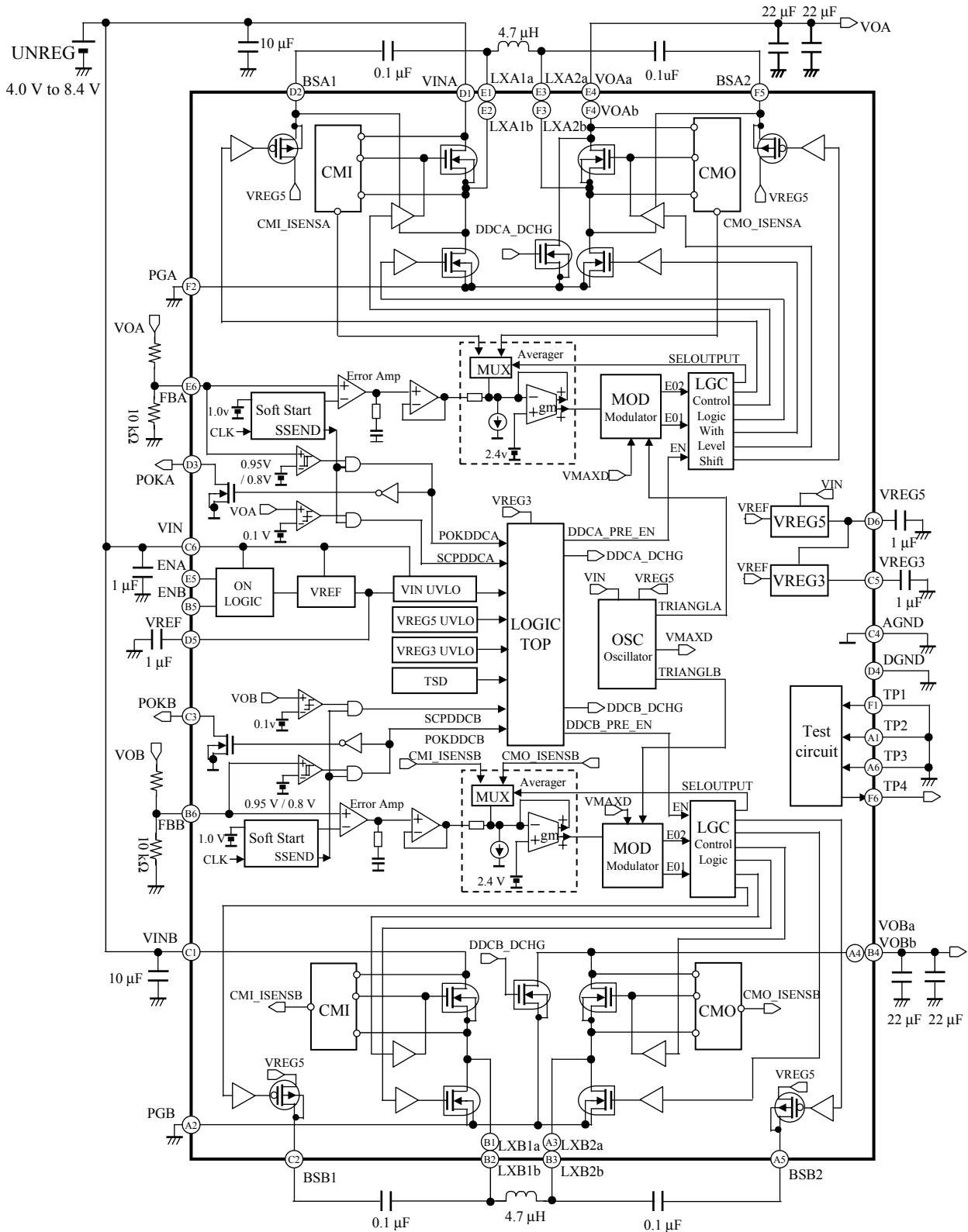

Note) This block diagram is for explaining functions. Some circuit blocks may be omitted, or simplified.

■ Pin Layout (Bottom View)

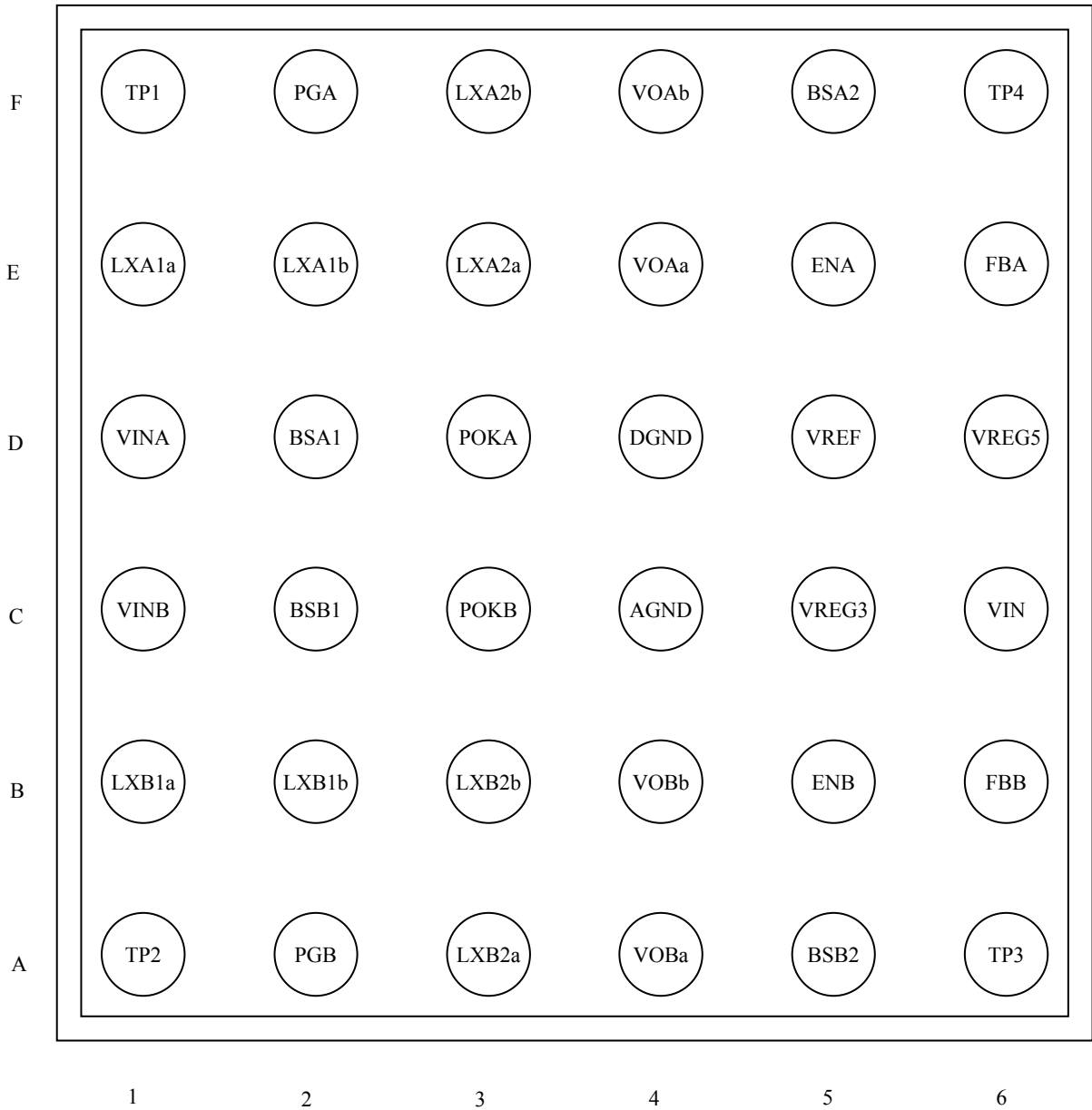

BOTTOM VIEW

- Notes) • Pin C1 (VINB) and Pin D1 (VINA) are connected via internal wiring.
 • Pin A2 (PGB) and Pin F2 (PGA) are connected via internal wiring.

■ Pin Descriptions

Pin No.	Pin Name	Type	Descriptions
A1	TP2	Input	Test circuit input
A2	PGB	Ground	PGND for channel-B
A3	LXB2a	Output	Coil connection for channel-B step-up
A4	VOBa	Output	Channel-B output
A5	BSB2	Input	Bootstrap for channel-B step-up
A6	TP3	Input	Test circuit input
B1	LXB1a	Output	Coil connection for channel-B step-down
B2	LXB1b	Output	Coil connection for channel-B step-down
B3	LXB2b	Output	Coil connection for channel-B step-up
B4	VOBb	Output	Channel-B output
B5	ENB	Input	Channel-B enable input
B6	FBB	Input	Feedback voltage input for channel-B
C1	VINB	Power Supply	Supply voltage input for channel-B
C2	BSB1	Input	Bootstrap for channel-B step-down
C3	POKB	Output	POK output for channel-B
C4	AGND	Ground	GND for analog circuit
C5	VREG3	Output	3.1-V regulator output
C6	VIN	Power Supply	Supply voltage input for internal circuits
D1	VINA	Power Supply	Supply voltage input for channel-A
D2	BSA1	Input	Bootstrap for channel-A step-down
D3	POKA	Output	POK output for channel-A
D4	DGND	Ground	GND for digital circuit
D5	VREF	Output	Reference voltage output
D6	VREG5	Output	5-V regulator output
E1	LXA1a	Output	Coil connection for channel-A step-down
E2	LXA1b	Output	Coil connection for channel-A step-down
E3	LXA2a	Output	Coil connection for channel-A step-up
E4	VOAa	Output	Channel-A output
E5	ENA	Input	Channel-A enable input
E6	FBA	Input	Feedback voltage input for channel-A
F1	TP1	Input	Test circuit input
F2	PGA	Ground	PGND for channel-A
F3	LXA2b	Output	Coil connection for channel-A step-up
F4	VOAb	Output	Channel-A output
F5	BSA2	Input	Bootstrap for channel-A step-up
F6	TP4	Output	Test circuit input

■ Absolute Maximum Ratings

Note) The absolute maximum ratings are the limit values beyond which the IC may be damaged. Operation is not guaranteed under these conditions.

A No.	Parameter	Symbol	Rating	Unit	Notes
1	Supply voltage	VIN, VINA, VINB	10	V	*1
2	Supply current	I _{CC}	—	A	—
3	Power dissipation	P _D	0.113	W	*2
4	Operating ambient temperature	T _{opr}	−20 to +85	°C	*3
5	Storage temperature	T _{stg}	−55 to +150	°C	*3

Notes) *1: The values are defined, provided that the IC is used within all of the above absolute maximum ratings including the power dissipation.

*2: The power dissipation shown is the value at T_a = 85°C for the independent (unmounted) IC package without a heat sink. When using this IC, refer to the P_D-T_a diagram of the package standard and design the heat radiation with sufficient margin not to exceed the allowable value based on the conditions of power supply voltage, load, and ambient temperature.

*3: All ratings are at T_a = 25°C, except the power dissipation, operating ambient temperature, and storage temperature.

■ Operating Supply Voltage Range

Parameter	Symbol	Range	Unit	Note
Supply voltage range	VIN, VINA, VINB	4.0 to 8.4	V	*1

Note) *1: The value is defined, provided that the IC is used within all of the above absolute maximum ratings including the power dissipation.

■ Allowable Current and Voltage Ranges

- Notes) • The allowable current and voltage ranges are limit values beyond which the IC may be damaged. Operation is not guaranteed under these conditions.
- Rating voltages are voltages on each pin, with respect to the GND. GND denotes the voltage of AGND, DGND, PGB and PGA.
(GND = AGND = DGND = PGA = PGB)
 - Do not apply external current or voltages to any pins except mentioned below.

Pin No.	Pin Name	Rating Voltage	Unit	Notes	Pin No.	Pin Name	Rating Voltage	Unit	Notes
E5 B5	ENA ENB	-0.3 to 3.6	V	—	E4 F4	VOAa VOAb	-0.3 to 10	V	*2
E6 B6	FBA FBB	-0.3 to 3.3	V	—	A4 B4	VOBa VOBb	-0.3 to 10	V	*2
D3 C3	POKA POKB	-0.3 to 3.6	V	—	E1 E2	LXA1a LXA1b	-0.3 to (VINA + 0.3)	V	*1 *2
D2	BSA1	-0.3 to (VINA + VREG5 + 0.3)	V	—	E3 F3	LXA2a LXA2b	-0.3 to (VOA + 0.3)	V	*1 *2
F5	BSA2	-0.3 to (VOA + VREG5 + 0.3)	V	—	B1 B2	LXB1a LXB1b	-0.3 to (VINB + 0.3)	V	*1 *2
C2	BSB1	-0.3 to (VINB + VREG5 + 0.3)	V	—	A3 B3	LXB2a LXB2b	-0.3 to (VOB + 0.3)	V	*1 *2
A5	BSB2	-0.3 to (VOB + VREG5 + 0.3)	V	—					

Notes) *1: Do not exceed 10 V for specified voltage.

*2: Applying external voltage into these pins is prohibited, because they are output pins.

■ Electrical Characteristics

Note) $T_a = 25^\circ\text{C} \pm 2^\circ\text{C}$, unless otherwise specified.

B No.	Parameter	Symbol	Conditions	Limits			Unit	Notes
				Min	Typ	Max		
Consumption Current Characteristics VIN = 8.4 V								
A1	Shutdown consumption current	ISHDN	ENA = ENB = 0 V	—	—	5	μA	—
UVLO Characteristics								
B1	VIN_UVLO detection voltage	VUUVL	—	3.0	3.30	—	V	—
B2	VIN_UVLO release voltage	VUUVLN	—	—	3.50	3.85	V	—
B3	VIN_UVLO hysteresis voltage	VHYSU	—	0.15	0.20	—	V	—
B4	VREG5_UVLO detection voltage	VR5UVL	—	3.0	3.3	—	V	—
B5	VREG5_UVLO release voltage	VR5UVLN	—	—	3.5	3.85	V	—
B6	VREG5_UVLO hysteresis voltage	VHYSR5	—	0.15	0.20	—	V	—
B7	VREG3_UVLO detection voltage	VR3UVL	—	2.30	2.55	—	V	—
B8	VREG3_UVLO release voltage	VR3UVLN	—	—	2.75	3.0	V	—
B9	VREG3_UVLO hysteresis voltage	VHYSR3	—	0.08	0.2	—	V	—
Enable Characteristics (ENA, ENB) VIN = 7.4 V								
C1	Input voltage (High)	VIH	—	2.2	—	3.3	V	—
C2	Input voltage (Low)	VIL	—	0	—	0.4	V	—
C3	Pull-down resistance	RPDWN	—	400	—	—	kΩ	—
REF Characteristics (Reference Voltage) VIN = 7.4 V, Input Capacitance: 1.0 μF (Rank-B), Output Capacitance: 1.0 μF (Rank-B)								
D1	VREF pin voltage	VREF	DDCA, B switching OFF	1.224	1.236	1.248	V	—
VREG Characteristics (Linear Power Supply) VIN = 7.4 V, Output Capacitance: 1.0 μF (Rank-B)								
E1	VREG5 output voltage	VREG5	No load	4.7	5.0	5.3	V	—
E2	VREG3 output voltage	VREG3	No load	2.95	3.1	3.25	V	—

■ Electrical Characteristics (continued)

Note) $T_a = 25^\circ\text{C} \pm 2^\circ\text{C}$, unless otherwise specified.

For the circuit current I_{out} , “+” denotes current flowing into the IC, and “-” denotes current flowing out from the IC.

B No.	Parameter	Symbol	Conditions	Limits			Unit	Notes
				Min	Typ	Max		
DDCA Characteristics (Synchronous Rectification / Step-up/down / Fixed Frequency / Current Mode / DC-DC Converter) Input Voltage: $V_{INA} = 7.4\text{ V}$, Output Voltage: $V_{out} = 5.5\text{ V}$, $ENB = 0\text{ V}$ (Unless otherwise specified) Input Capacitance: $10\text{ }\mu\text{F}$, Output Capacitance: $44\text{ }\mu\text{F}$ (Effective value: at least $22\text{ }\mu\text{F}$) Choke Coil: NR6020T4R7M, $L = 4.7\text{ }\mu\text{H}$								
F1	Consumption current A0	ICCA	$V_{IN} = 8.4\text{ V}$, no-load output $EN_A = 3.3\text{ V}$, $EN_B = 0\text{ V}$ $I_{outA} = 0\text{ A}$, $V_{outA} = 5.5\text{ V}$	—	10	15	mA	—
F2	Output voltage A1	VODDCA1	$V_{INA} = 4.0\text{ V}$, 8.4 V $I_{out} = -1\text{ mA}$	5.417	5.5	5.583	V	—
F3	Output voltage A2	VODDCA2	$V_{INA} = 4.0\text{ V}$ $I_{out} = -220\text{ mA}$	5.417	5.5	5.583	V	—
F4	Output voltage A3	VODDCA3	$V_{INA} = 8.4\text{ V}$ $I_{out} = -850\text{ mA}$	5.417	5.5	5.583	V	—
F5	Soft start time 1	SSDDCA1	$V_{INA} = 4.0\text{ V}$ $V_{out} = 5.5\text{ V}$, $I_{out} = -1\text{ mA}$	3.6	4.6	5.6	ms	—
F6	Soft start time 2	SSDDCA2	$V_{INA} = 8.4\text{ V}$ $V_{out} = 5.5\text{ V}$, $I_{out} = -1\text{ mA}$	3.6	4.6	5.6	ms	—
F10	POK detection voltage	VTHDPOKA	—	75	80	85	%	—
F11	POK release voltage	VTHRPOKA	—	91	95	99	%	—
F12	SCP detection delay time	SCDELDDCA	—	70	100	130	ms	—
F13	Rapid SCP detection voltage	VRSCDDCB	—	50	100	150	mV	—
F14	On resistance of discharge switch	RDCDDCA	—	—	—	100	Ω	—
F15	On resistance of high-side input switch	RONH1DDCA	$V_{INA} = 7.4\text{ V}$	—	0.125	0.18	Ω	—
F16	On resistance of low-side input switch	RONL1DDCA	—	—	0.14	0.20	Ω	—
F17	On resistance of high-side output switch	RONH2DDCA	$V_{out} = 5.5\text{ V}$	—	0.125	0.18	Ω	—
F18	On resistance of low-side output switch	RONL2DDCA	—	—	0.14	0.20	Ω	—
F19	Switching frequency 0	FSDDCA	$V_{INA} = 4.0\text{ V}$ to 8.4 V	0.8	1	1.2	MHz	*1
F20	Load regulation	REGINDDCA	$V_{INA} = 4.0\text{ V}$, 8.4 V $\Delta V_{out} = V_{out}(-1\text{ mA}) - V_{out}(-220, -850\text{ mA}) $	—	—	82.5	mV	—
F21	Line regulation	REGLDDCA	$I_{out} = -1\text{ mA}$ $\Delta V_{out} = V_{out}(V_{INA} = 4.0\text{ V}) - V_{out}(V_{INA} = 8.4\text{ V}) $	—	—	82.5	mV	—
F22	On resistance of POKA pin	RONPOKA	—	—	—	1.0	k Ω	—

Note) *1: This indicates the characteristics in test mode.

■ Electrical Characteristics (continued)

Note) $T_a = 25^{\circ}\text{C} \pm 2^{\circ}\text{C}$, unless otherwise specified.

For the circuit current I_{out} , “+” denotes current flowing into the IC, and “-” denotes current flowing out from the IC.

B No.	Parameter	Symbol	Conditions	Limits			Unit	Notes
				Min	Typ	Max		
DDCB Characteristics (Synchronous Rectification / Step-up/down / Fixed Frequency / Current Mode / DC-DC Converter) Input Voltage: $V_{INB} = 7.4\text{ V}$, Output Voltage: $V_{out} = 7.0\text{ V}$, $E_{NA} = 0\text{ V}$ (Unless otherwise specified) Input Capacitance: $10\text{ }\mu\text{F}$, Output Capacitance: $44\text{ }\mu\text{F}$ (Effective value: at least $22\text{ }\mu\text{F}$) Choke Coil: NR6020T4R7M, $L = 4.7\text{ }\mu\text{H}$								
G1	Consumption current B0	ICCB	$V_{IN} = 8.4\text{ V}$, no-load output $E_{NA} = 0\text{ V}$, $E_{NB} = 3.3\text{ V}$ $I_{outB} = 0\text{ A}$, $V_{outB} = 7.0\text{ V}$	—	10	15	mA	—
G2	Output voltage B1	VODDCB1	$V_{INB} = 4.0\text{ V}$, 8.4 V $I_{out} = -1\text{ mA}$	6.895	7.0	7.105	V	—
G3	Output voltage B2	VODDCB2	$V_{INB} = 4.0\text{ V}$ $I_{out} = -160\text{ mA}$	6.895	7.0	7.105	V	—
G4	Output voltage B3	VODDCB4	$V_{INB} = 8.4\text{ V}$ $I_{out} = -800\text{ mA}$	6.895	7.0	7.105	V	—
G5	Soft start time 1	SSDDCB1	$V_{INB} = 4.0\text{ V}$ $V_{out} = 5.5\text{ V}$, $I_{out} = -1\text{ mA}$	3.6	4.6	5.6	ms	—
G6	Soft start time 2	SSDDCB2	$V_{INB} = 8.4\text{ V}$ $V_{out} = 5.5\text{ V}$, $I_{out} = -1\text{ mA}$	3.6	4.6	5.6	ms	—
G10	POK detection voltage	VTHDPOKB	—	75	80	85	%	—
G11	POK release voltage	VTHRPOKB	—	91	95	99	%	—
G12	SCP detection delay time	SCDELDDCA	—	70	100	130	ms	—
G13	Rapid SCP detection voltage	VRSCDDCB	—	50	100	150	mV	—
G14	On resistance of discharge switch	RDCDD2P9	—	—	—	100	Ω	—
G15	On resistance of high-side input switch	RONH1DDCB	$V_{INB} = 7.4\text{ V}$	—	0.10	0.14	Ω	—
G16	On resistance of low-side input switch	RONL1DDCB	—	—	0.14	0.20	Ω	—
G17	On resistance of high-side output switch	RONH2DDCB	$V_{out} = 7.0\text{ V}$	—	0.10	0.14	Ω	—
G18	On resistance of low-side output switch	RONL2DDCB	—	—	0.14	0.20	Ω	—
G19	switching frequency 0	FSDDCB	$V_{INB} = 4.0\text{ V}$ to 8.4 V	0.8	1	1.2	MHz	*1
G20	Load regulation	REGINDDCB	$V_{INB} = 4.0\text{ V}$, 8.4 V $\Delta V_{out} = V_{out}(-1\text{ mA}) - V_{out}(-160, -800\text{ mA}) $	—	—	105	mV	—
G21	Line regulation	REGLDDCB	$I_{out} = -1\text{ mA}$ $\Delta V_{out} = V_{out}(V_{INB} = 4.0\text{ V}) - V_{out}(V_{INB} = 8.4\text{ V}) $	—	—	105	mV	—
G22	On resistance of POKB pin	RONPOKB	—	—	—	1.0	k Ω	—

Note) *1: This indicates the characteristics in test mode.

■ Electrical Characteristics (Reference Values for Design)

Note) $T_a = 25^\circ\text{C} \pm 2^\circ\text{C}$, unless otherwise specified.

For the circuit current I_{out} , “+” denotes current flowing into the IC, and “-” denotes current flowing out from the IC.

If, by any chance, the problem caused by these characteristics occurs, we will respond in good faith to user concerns.

B No.	Parameter	Symbol	Conditions	Limits			Unit	Notes
				Min	Typ	Max		
Enable Characteristics (ENA, ENB) $V_{IN} = 7.4 \text{ V}$								
c1	Hysteresis voltage	VHYS	—	—	0.2	—	V	—
REF Characteristics (Reference Voltage) $V_{IN} = 7.4 \text{ V}$, Input Capacitance: $1.0 \mu\text{F}$ (Rank-B), Output Capacitance: $1.0 \mu\text{F}$ (Rank-B)								
d1	VREF pin voltage	VREF	$T_a = -20^\circ\text{C}$ to 85°C $V_{in} = 1.8 \text{ V}$ to 5.41 V $I_{out} = 0 \mu\text{A}$	1.218	1.236	1.254	V	—
TSD Characteristics (Reference Voltage) $V_{IN} = 7.4 \text{ V}$								
h1	TSD detection temperature	TSD	—	150	170	—	$^\circ\text{C}$	—

■ Electrical Characteristics (Reference Values for Design) (continued)

Note) $T_a = 25^\circ\text{C} \pm 2^\circ\text{C}$, unless otherwise specified.

For the circuit current I_{out} , “+” denotes current flowing into the IC, and “-” denotes current flowing out from the IC.

If, by any chance, the problem caused by these characteristics occurs, we will respond in good faith to user concerns.

B No.	Parameter	Symbol	Conditions	Limits			Unit	Notes
				Min	Typ	Max		
DDCA Characteristics (Synchronous Rectification / Step-up/down / Fixed Frequency / Current Mode / DC-DC Converter) Input Voltage: $V_{INA} = 7.4\text{ V}$, Output Voltage: $V_{out} = 5.5\text{ V}$ (Unless otherwise specified) Input Capacitance: $10\ \mu\text{F}$, Output Capacitance: $44\ \mu\text{F}$ (Effective value: at least $22\ \mu\text{F}$) Choke Coil: NR6020T4R7M, $L = 4.7\ \mu\text{H}$								
f1	FBA pin voltage	VFBA	$T_a = -20^\circ\text{C}$ to 85°C , $V_{INA} = 4.0\text{ V}$ to 8.4 V	0.98	1.0	1.02	V	—
f2	Input bias current of FBA pin	IFBA	—	—	-10	—	nA	—
f3	Setting range of output voltage	VOUTA	—	4.5	—	6.0	V	—
f4	Output voltage	VOA	$T_a = -20^\circ\text{C}$ to 85°C , $V_{INA} = 4.0\text{ V}$ to 8.4 V $I_{out} = -1\text{ mA}$ to -850 mA The dispersion of external resistance connected to FBA pin is ignored.	5.39	5.50	5.61	V	—
f5	Output ripple voltage	VOAR	$V_{INA} = 4.0\text{ V}$, 8.4 V $I_{out} = -1\text{ mA}$ to -850 mA $\text{ESR}(\text{Co}) = 2.5\text{ m}\Omega$	—	25	—	mV	—
f6	Switching frequency	FSA	$V_{INA} = 4.0\text{ V}$ to 8.4 V	0.75	1	1.25	MHz	—
f7	Maximum duty cycle of step-up	DMAXA	$V_{INA} = 4.0\text{ V}$ to 8.4 V	65	80	95	%	—

■ Electrical Characteristics (Reference Values for Design) (continued)

Note) $T_a = 25^\circ\text{C} \pm 2^\circ\text{C}$, unless otherwise specified.

For the circuit current I_{out} , “+” denotes current flowing into the IC, and “-” denotes current flowing out from the IC.

If, by any chance, the problem caused by these characteristics occurs, we will respond in good faith to user concerns.

B No.	Parameter	Symbol	Conditions	Limits			Unit	Notes
				Min	Typ	Max		
DDCB Characteristics (Synchronous Rectification / Step-up/down / Fixed Frequency / Current Mode / DCDC Converter) Input Voltage: $V_{INB} = 7.4\text{ V}$, Output Voltage: $V_{out} = 7.0\text{ V}$ (Unless otherwise specified) Input Capacitance: $10\ \mu\text{F}$, Output Capacitance: $44\ \mu\text{F}$ (Effective value: at least $22\ \mu\text{F}$) Choke Coil: NR6020T4R7M, $L = 4.7\ \mu\text{H}$								
g1	FBB pin voltage	VFBB	$T_a = -20^\circ\text{C}$ to 85°C , $V_{INB} = 4.0\text{ V}$ to 8.4 V	0.98	1.0	1.02	V	—
g2	Input bias current of FBB pin	IFBB	—	—	-10	—	nA	—
g3	Setting range of output voltage	VOUTB	—	4.8	—	7.0	V	—
g4	Output voltage 1	VOB1	$T_a = -20^\circ\text{C}$ to 85°C , $V_{INB} = 4.0\text{ V}$ to 8.4 V Output voltage: $V_{out} = 7.0\text{ V}$ $I_{out} = -1\text{ mA}$ to -800 mA The dispersion of external resistance connected to FBB pin is ignored.	6.86	7.0	7.14	V	—
g5	Output voltage 2	VOB2	$T_a = -20^\circ\text{C}$ to 85°C , $V_{INB} = 4.0\text{ V}$ to 8.4 V Output voltage: $V_{out} = 4.85\text{ V}$ $I_{out} = -1\text{ mA}$ to -1250 mA The dispersion of external resistance connected to FBB pin is ignored.	4.753	4.85	4.947	V	—
g6	Output ripple voltage 1	VOBR1	$V_{INB} = 4.0\text{ V}, 8.4\text{ V}$ Output voltage: $V_{out} = 7.0\text{ V}$ $I_{out} = -1\text{ mA}$ to -800 mA $\text{ESR}(C_o) = 2.5\text{ m}\Omega$	—	30	—	mV	—
g7	Output ripple voltage 2	VOBR2	$V_{INB} = 4.0\text{ V}, 8.4\text{ V}$ Output voltage: $V_{out} = 4.85\text{ V}$ $I_{out} = -1\text{ mA}$ to -1250 mA $\text{ESR}(C_o) = 2.5\text{ m}\Omega$	—	45	—	mV	—
g8	Switching frequency	FSB	$V_{INB} = 4.0\text{ V}$ to 8.4 V	0.75	1	1.25	MHz	—
g9	Maximum duty cycle of step-up	DMAXB	$V_{INB} = 4.0\text{ V}$ to 8.4 V	65	80	95	%	—

■ Technical Data

1. Specifications of Power Supply Block

• Specifications of DC-DC converter

Name	Control				Input Voltage (V)		Output Voltage (V)		POK	OVP	SCP	Load Switch	Discharge Switch
	Type	Synchronous Rectification	Mode	System	Min	Max	Min	Max					
DDCA	Step-up/down	Yes	Average current	Fixed frequency	4.0	8.4	4.5	6.0	Yes	—	Yes	—	Yes
DDCB	Step-up/down	Yes	Average current	Fixed frequency	4.0	8.4	4.8	7.0	Yes	—	Yes	—	Yes

■ Technical Data (continued)

2. Timing Chart

Note) These characteristics are reference values for design, and are not guaranteed.

- UNREG_IN → ENABLE → START (DDCB: Disable)

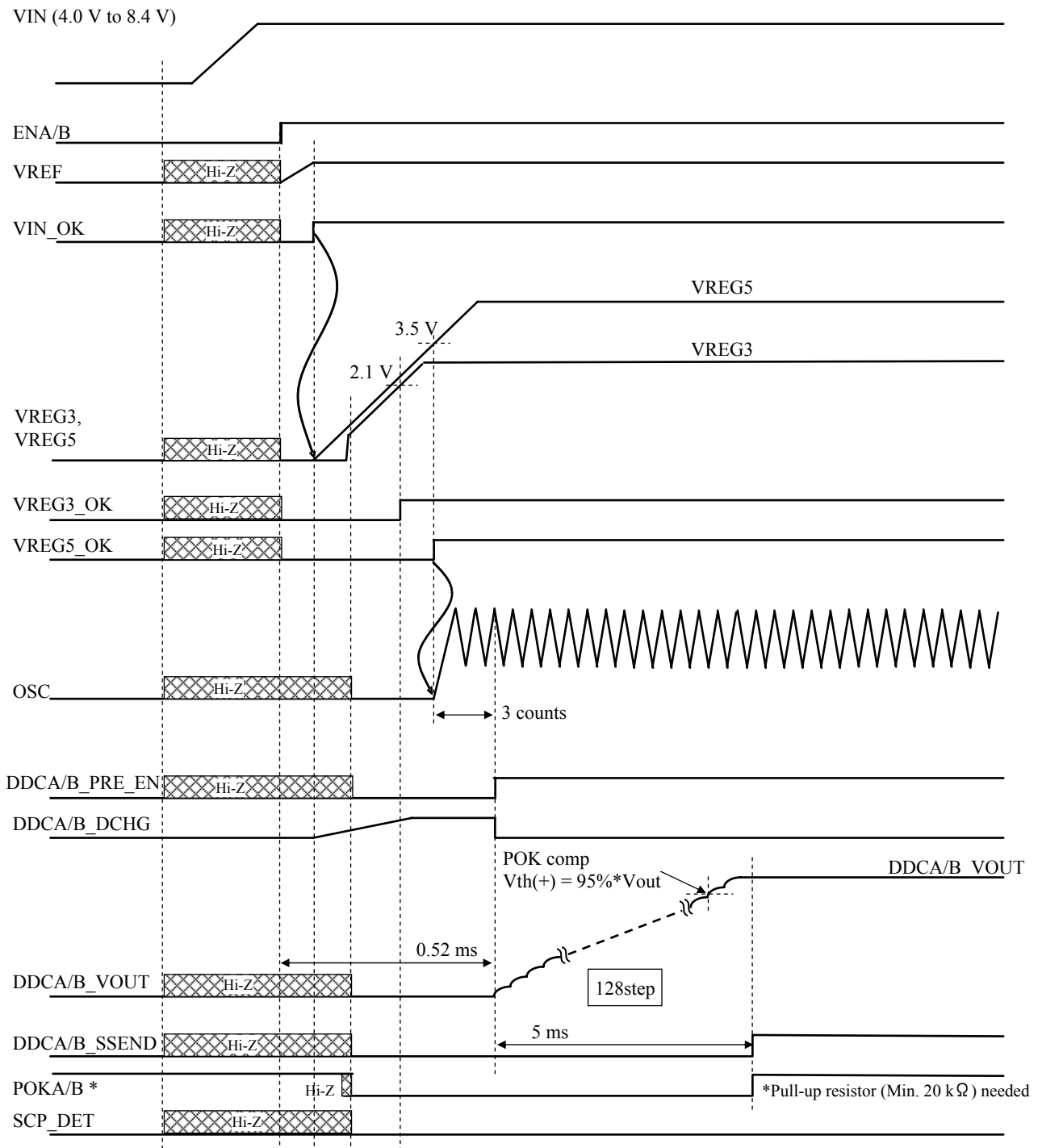

■ Technical Data (continued)
 2. Timing Chart (continued)

Note) These characteristics are reference values for design, and are not guaranteed.

- UNREG_IN → ENABLE-START (OUTPUT-GND short / DDCB: Disable)

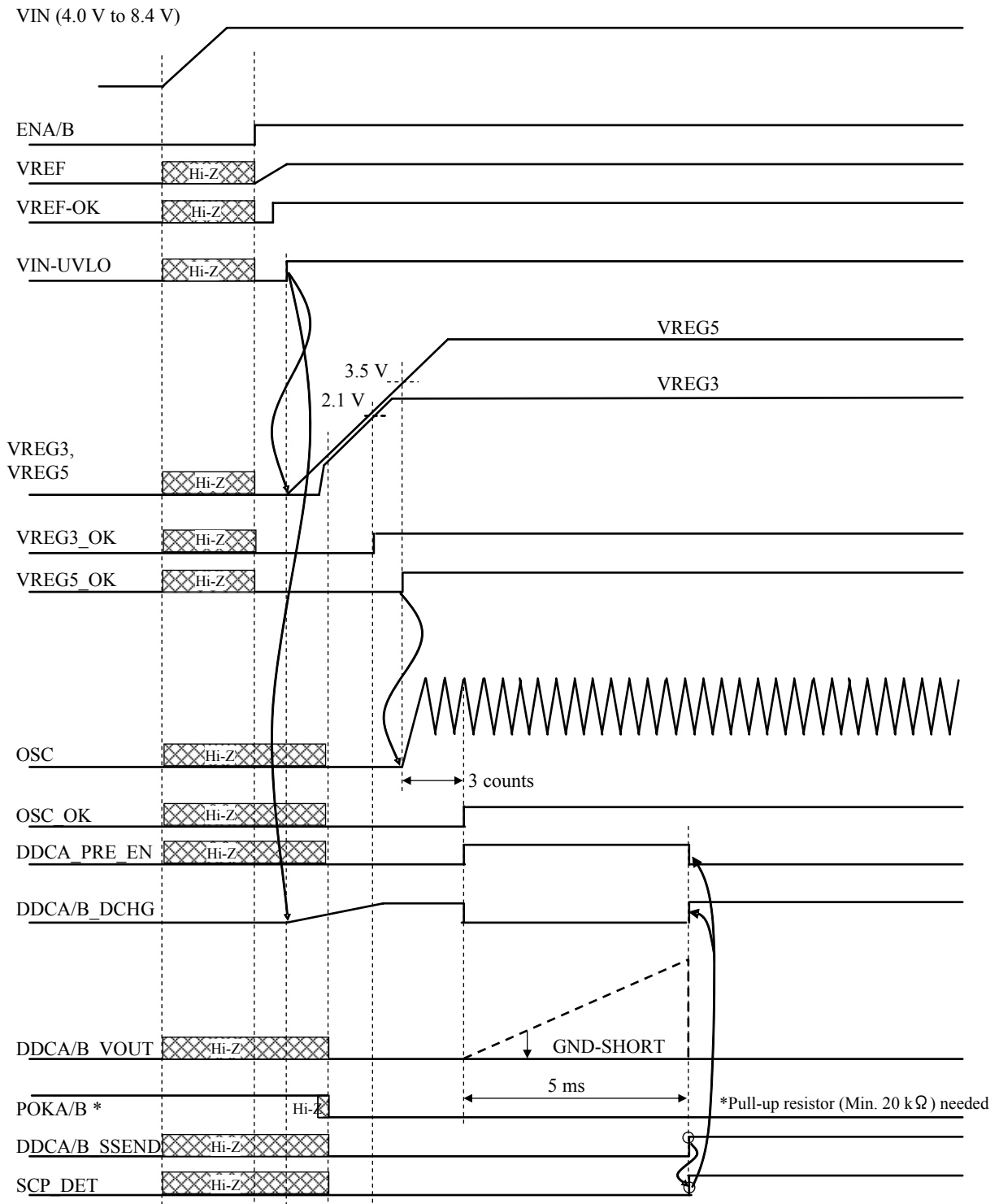

■ Technical Data (continued)

2. Timing Chart (continued)

Note) These characteristics are reference values for design, and are not guaranteed.

- SCPDET → STOP → ENA "H" → "L" (DDCB: Disable)

VIN (4.0 V to 8.4 V)

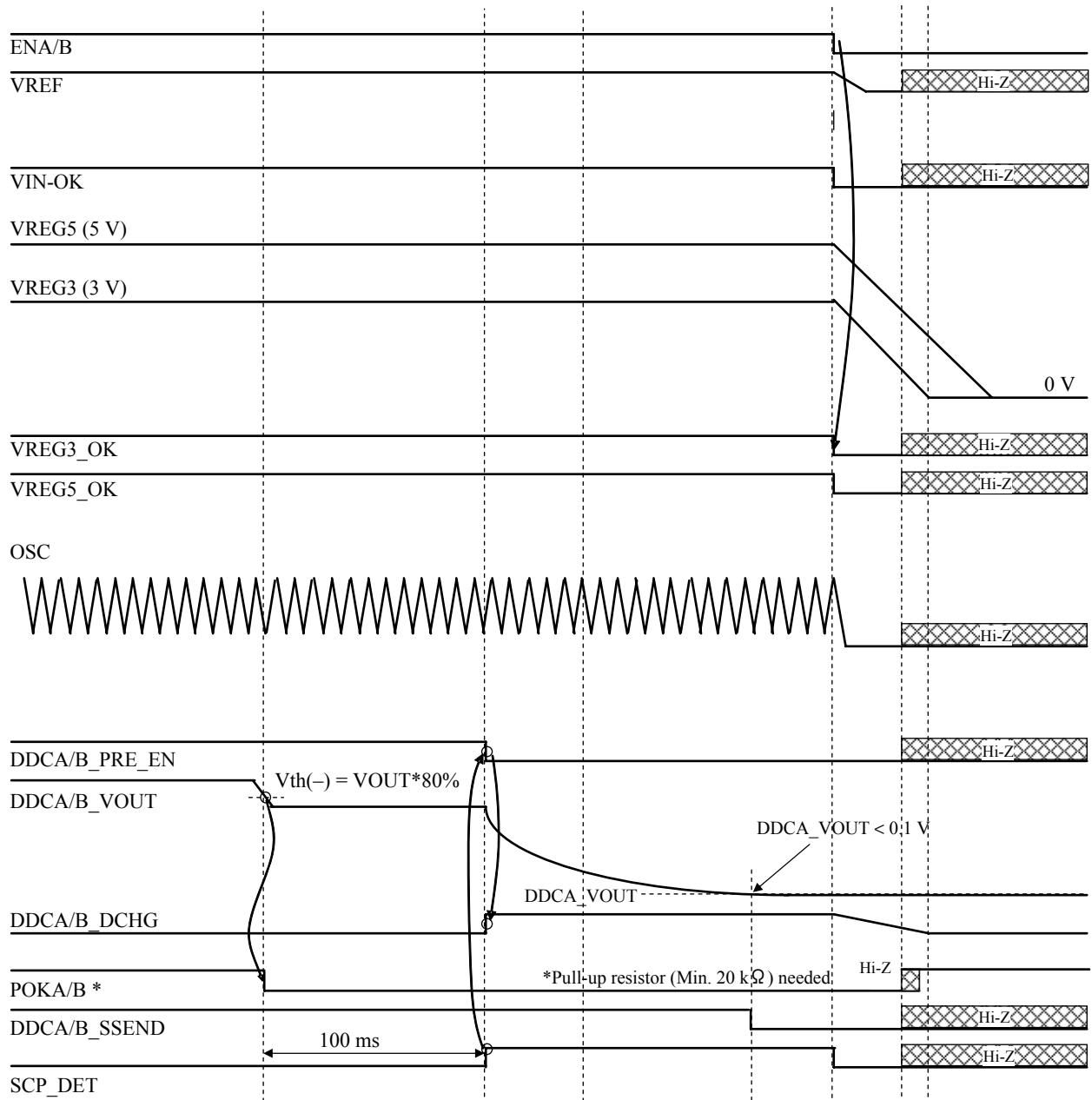

■ Technical Data (continued)

2. Timing Chart (continued)

Note) These characteristics are reference values for design, and are not guaranteed.

- SCPDET (OUTPUT-GND short) → STOP → ENA "H" → "L" (DDCB: Disable)

VIN (4.0 V to 8.4 V)

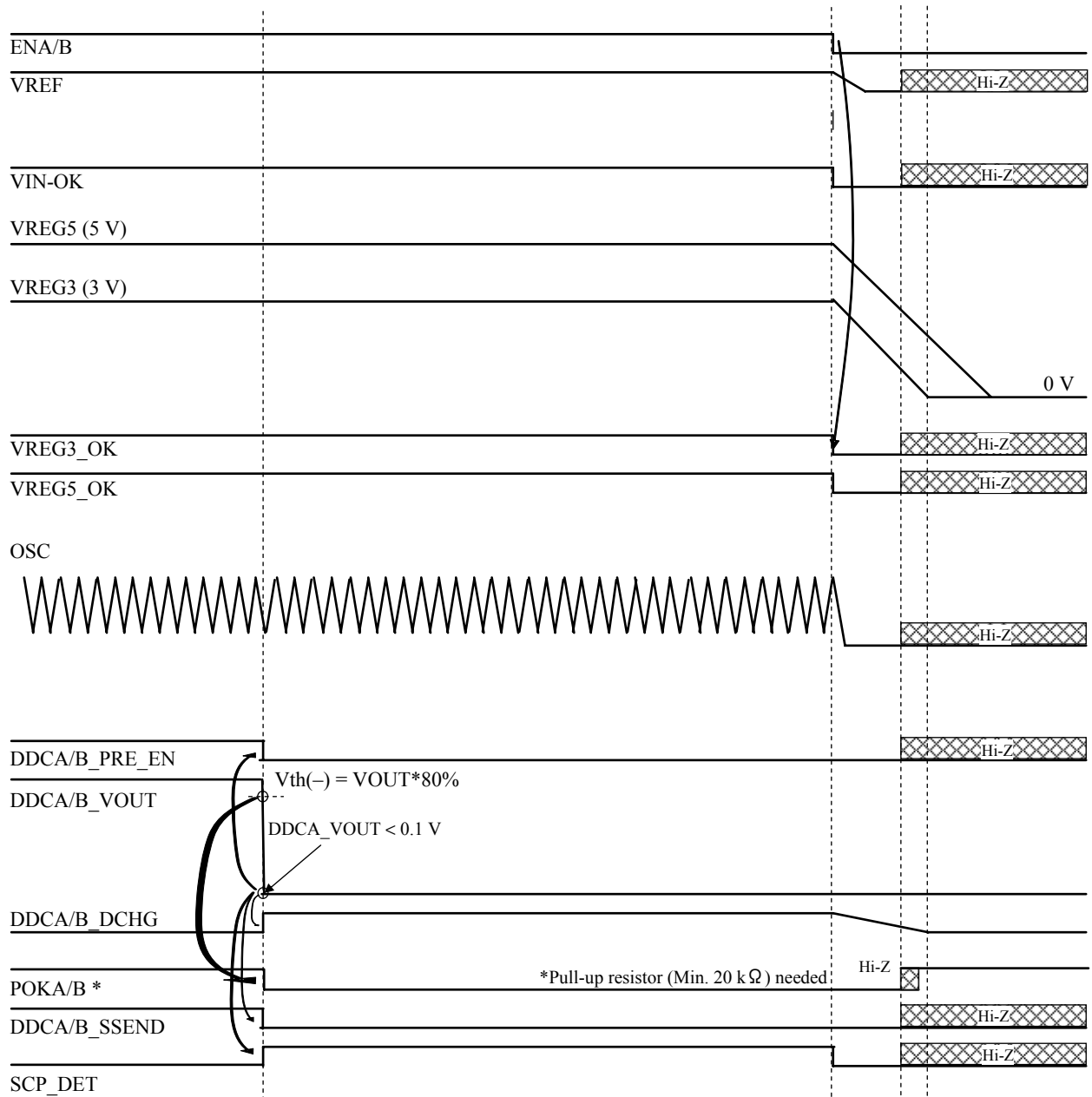

■ Technical Data (continued)

2. Timing Chart (continued)

Note) These characteristics are reference values for design, and are not guaranteed.

- VIN = 8.4 V → VIN = 3.0 V → VIN = 8.4 V (DDCB: Disable)

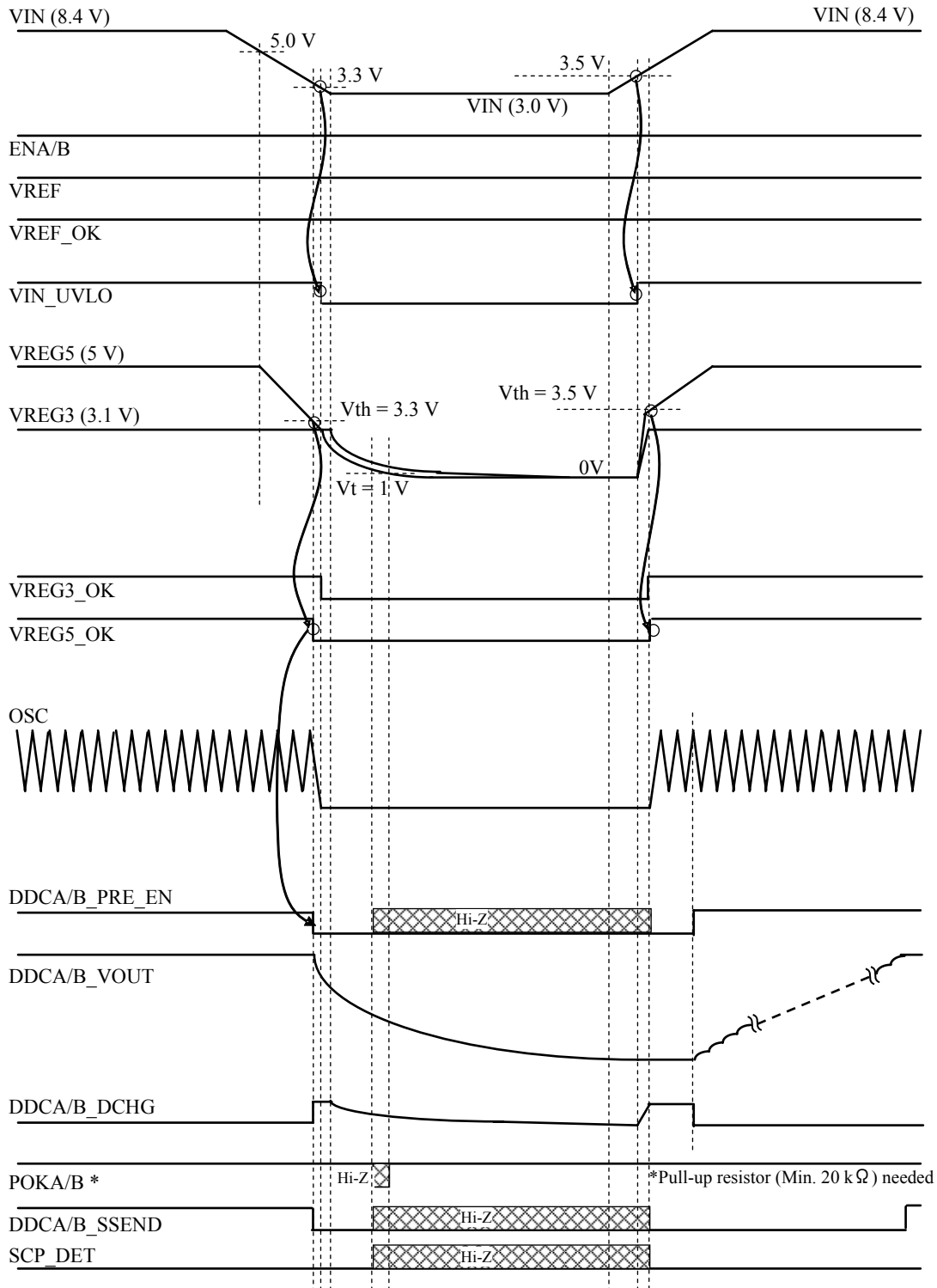

■ Technical Data (continued)
 2. Timing Chart (continued)

Note) These characteristics are reference values for design, and are not guaranteed.

- ENA "H" → TSD-DETECT → ENA "L" (DDCB: Disable)

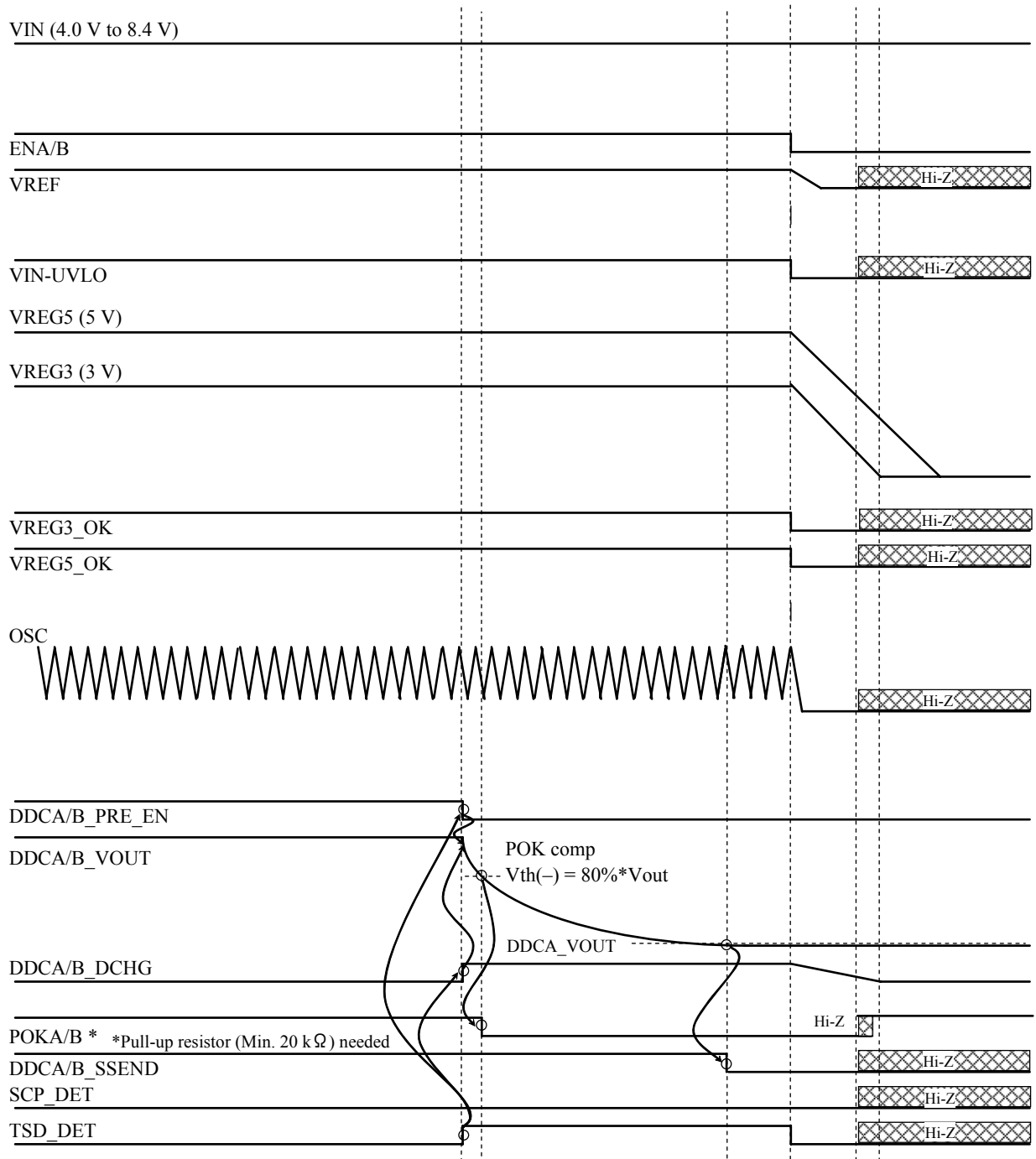

■ Technical Data (continued)

3. I/O Block Circuit Diagrams and Pin Function Descriptions







Note) These characteristics are reference values for design, and are not guaranteed.

Pin No.	Waveform and Voltage	Internal Circuit	Impedance	Descriptions
E1	<p>VINA 0 V</p>	<p>VINA E1 E2 PGA</p>	—	LXA1a Coil connection for channel-A step-down
E2				LXA1b Coil connection for channel-A step-down
E3	<p>VOA 0 V</p>	<p>VOA E3 F3 PGA</p>	—	LXA2a Coil connection for channel-A step-up
F3				LXA2b Coil connection for channel-A step-up
E4	<p>DC 4.5 V to 6.0 V</p>	<p>E4 F4 LXA2 AGND PGA</p>	—	VOAa Channel-A output
F4				VOAb Channel-A output
D2	<p>VINA+VREG5 0 V</p>	<p>VINA D2 VREG5 Pin E1, E2 LXA1a, LXA1b PGA</p>	—	BSA1 Bootstrap for channel-A step-down
F5	<p>VOA+VREG5 0 V</p>	<p>VOA F5 VREG5 Pin E3, F3 LXA2a, LXA2b PGA</p>	—	BSA2 Bootstrap for channel-A step-up

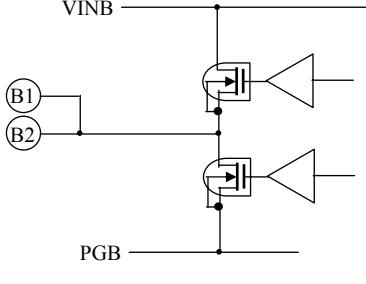
■ Technical Data (continued)

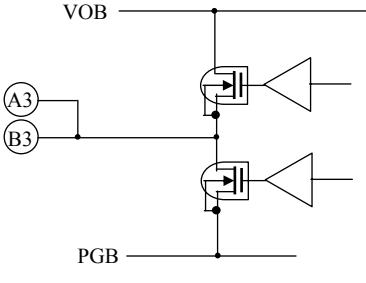
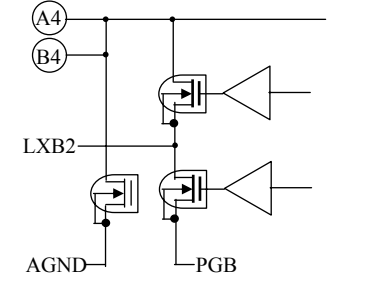
3. I/O Block Circuit Diagrams and Pin Function Descriptions (continued)

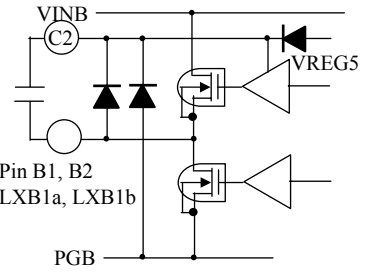
Note) These characteristics are reference values for design, and are not guaranteed.

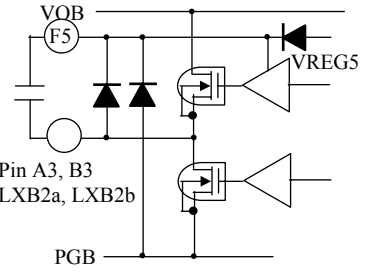
Pin No.	Waveform and Voltage	Internal Circuit	Impedance	Descriptions
B1			—	LXB1a Coil connection for channel-B step-down
B2				LXB1b Coil connection for channel-B step-down
A3			—	LXB2a Coil connection for channel-B step-up
B3				LXB2b Coil connection for channel-B step-up
A4	DC 4.8 V to 7.0 V		—	VOBa Channel-B output
B4				VOBb Channel-B output
C2			—	BSB1 Bootstrap for channel-B step-down
A5			—	BSB2 Bootstrap for channel-B step-up