



Chipsmall Limited consists of a professional team with an average of over 10 year of expertise in the distribution of electronic components. Based in Hongkong, we have already established firm and mutual-benefit business relationships with customers from,Europe,America and south Asia,supplying obsolete and hard-to-find components to meet their specific needs.

With the principle of “Quality Parts,Customers Priority,Honest Operation,and Considerate Service”,our business mainly focus on the distribution of electronic components. Line cards we deal with include Microchip,ALPS,ROHM,Xilinx,Pulse,ON,Everlight and Freescale. Main products comprise IC,Modules,Potentiometer,IC Socket,Relay,Connector.Our parts cover such applications as commercial,industrial, and automotives areas.

We are looking forward to setting up business relationship with you and hope to provide you with the best service and solution. Let us make a better world for our industry!



## Contact us

Tel: +86-755-8981 8866 Fax: +86-755-8427 6832

Email & Skype: info@chipsmall.com Web: www.chipsmall.com

Address: A1208, Overseas Decoration Building, #122 Zhenhua RD., Futian, Shenzhen, China



## 4×3 Matrix LED Driver LSI with Step-up Charge Pump Control Circuit

### FEATURES

- 4 x 3 LED Matrix Driver  
(Total LED that can be driven = 12)
- LED maximum current selectable
- Step-up charge pump DC/DC converter : 200 mA
- I<sup>2</sup>C interface (Slave address selectable)
- 24 pin Wafer Level Chip Size Package (WLCSP)

### DESCRIPTION

AN32155A is a 4 x 3 LED driver equipped with a step-up charge pump circuit.

### APPLICATIONS

- Mobile Phone
- Smart Phone
- PCs
- Game Consoles
- Home Appliances etc.

### TYPICAL APPLICATION

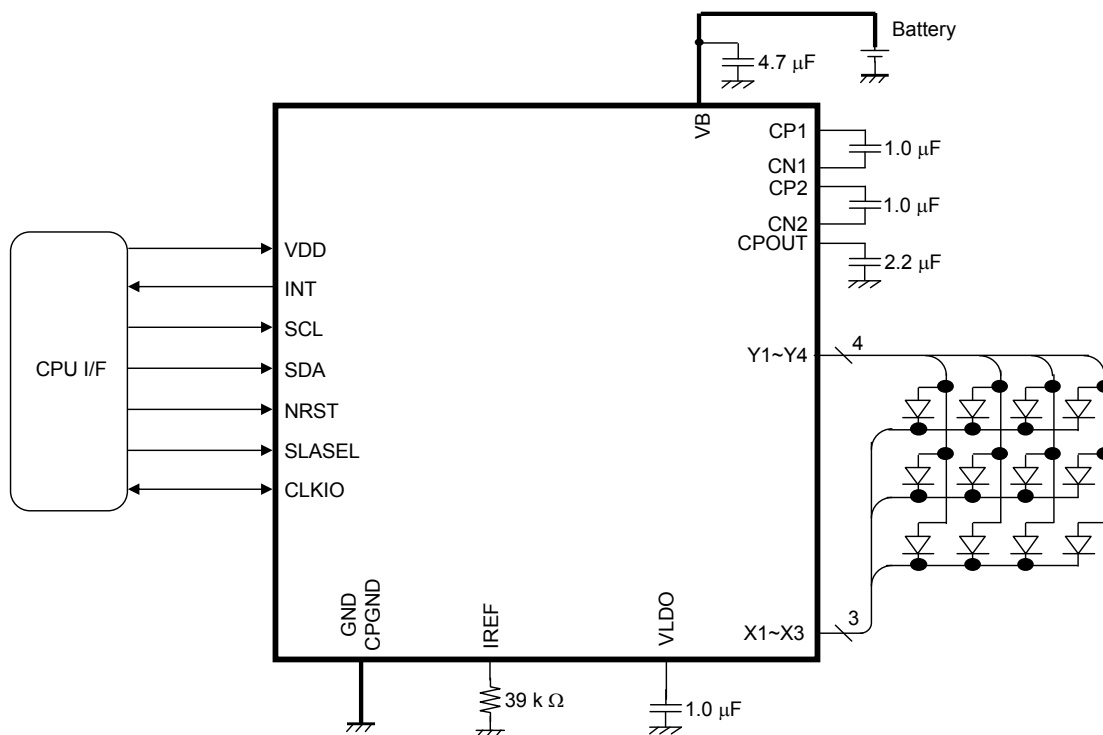

Note)

The application circuit is an example. The operation of the mass production set is not guaranteed. Sufficient evaluation and verification is required in the design of the mass production set. The Customer is fully responsible for the incorporation of the above illustrated application circuit in the design of the equipment.

**ABSOLUTE MAXIMUM RATINGS**

Parameter	Symbol	Rating	Unit	Note
Supply voltage	$V_{B\_MAX}$	6.5	V	*1
	$CPOUT_{MAX}$	6.5	V	*1
	$VDD_{MAX}$	6.5	V	*1
Operating ambience temperature	$T_{opr}$	- 30 to + 85	°C	*2
Operating junction temperature	$T_j$	- 30 to + 125	°C	*2
Storage temperature	$T_{stg}$	- 55 to + 125	°C	*2
Input Voltage Range	SLASEL, SCL, SDA, CLKIO, NRST	- 0.3 to 6.5	V	—
Output Voltage Range	CLKIO, VLDO, INT, Y1, Y2, Y3, Y4, X1, X2, X3	- 0.3 to 6.5	V	—
ESD	HBM	2.0	kV	—

Note) This product may sustain permanent damage if subjected to conditions higher than the above stated absolute maximum rating. This rating is the maximum rating and device operating at this range is not guaranteeable as it is higher than our stated recommended operating range.

When subjected under the absolute maximum rating for a long time, the reliability of the product may be affected.

\*1:  $V_{B\_MAX} = V_B$ ,  $VDD_{MAX} = VDD$ ,  $CPOUT_{MAX} = CPOUT$

The values under the condition not exceeding the above absolute maximum ratings and the power dissipation.

\*2: Except for the power dissipation, operating ambient temperature, and storage temperature, all ratings are for  $T_a = 25^\circ\text{C}$ .

**POWER DISSIPATION RATING**

PACKAGE	$\theta_{JA}$	$P_D (Ta=25^\circ\text{C})$	$P_D (Ta=85^\circ\text{C})$
24 pin Wafer Level Chip Size Package (WLCSP)	197.29 °C /W	0.507 W	0.2028 W

Note) For the actual usage, please refer to the  $P_D$ - $T_a$  characteristics diagram in the package specification, follow the power supply voltage, load and ambient temperature conditions to ensure that there is enough margin and the thermal design does not exceed the allowable value.



**CAUTION**

Although this LSI has built-in ESD protection circuit, it may still sustain permanent damage if not handled properly. Therefore, proper ESD precautions are recommended to avoid electrostatic damage to the MOS gates

**RECOMMENDED OPERATING CONDITIONS**

Parameter	Symbol	Min.	Typ.	Max.	Unit	Note
Supply voltage range	VB (CPOUT)	3.1	3.6	6.0	V	*1
	VDD	1.7	1.85	6.0	V	*1, 2
Input Voltage Range	SLASEL, SCL, SDA, CLKIO	- 0.3	—	VDD + 0.3	V	*3
	NRST	- 0.3	—	VB + 0.3	V	*3
Output Voltage Range	CLKIO	- 0.3	—	VDD + 0.3	V	*3
	VLDO, INT, Y1, Y2, Y3, Y4, X1, X2, X3	- 0.3	—	VB + 0.3	V	*3

- Note) \*1: The values under the condition not exceeding the above absolute maximum ratings and the power dissipation.  
Do not apply external currents and voltages to any pin not specifically mentioned.  
Voltage values, unless otherwise specified, are with respect to GND. GND is voltage for GND and CPGND.  
VDD is voltage for VDD. VB is voltage for VB and VBCP. VLED is voltage for VLED.
- \*2: VDD voltage must be applied in the range which does not exceed VB voltage.
- \*3: (VDD + 0.3 ) V must not exceed 6.5 V. (VB + 0.3 ) V must not exceed 6.5 V.



**ELECTRICAL CHARACTERISTICS**

VB = 3.6 V, VDD = 1.85 V

Note) T<sub>a</sub> = 25 °C ± 2 °C unless otherwise specified.

Parameter	Symbol	Condition	Limits			Unit	Note
			Min	Typ	Max		
<b>Current consumption</b>							
Current consumption (1) at OFF mode	ICC1	VB = 3.6 V NRST = 0V	—	0	1	μA	—
Current consumption (2) at OFF mode	ICC2	VB = 3.6 V NRST = High	—	35	60	μA	—
Current consumption (3) at VB through mode	ICC3	VB = 4.6 V NRST = High VB through mode I <sub>CPOUT</sub> = 0 mA LED = current 0 mA setting	—	0.26	0.52	mA	—
Current consumption (4) at charge pump 1.5× (600 kHz operation)	ICC4	VB = 3.1 V NRST = High Charge Pump ON, 1.5×, 600 kHz operation mode LED = current 0 mA setting	—	1.3	2.6	mA	—
Current consumption (5) at charge pump 1.5× (1.2 MHz operation)	ICC5	VB = 3.1 V NRST = High Charge Pump ON, 1.5×, 1.2 MHz operation mode LED = current 0 mA setting	—	2.3	4.6	mA	—
<b>Internal oscillator</b>							
Oscillation frequency	FDC1	VB = 3.1 V to 4.6 V	1.92	2.40	2.88	MHz	—
<b>VB through switch</b>							
Resistance at switch ON	RVBS	VB = 4.5 V I <sub>CPOUT</sub> = -30 mA RVBS = (V <sub>VB</sub> - V <sub>CPOUT</sub> ) / 30 mA	—	1.0	2.0	Ω	—
<b>SCAN switch</b>							
Resistance at switch ON	RSCAN	CPOUT = 4.5 V I <sub>y1</sub> to I <sub>y4</sub> = 20 mA	—	1.6	3.0	Ω	—

**ELECTRICAL CHARACTERISTICS (continued)**

VB = 3.6 V, VDD = 1.85 V

Note) T<sub>a</sub> = 25 °C ± 2 °C unless otherwise specified.

Parameter	Symbol	Condition	Limits			Unit	Note
			Min	Typ	Max		
<b>Current regulator (matrix)</b>							
Output current (1)	IMX1	At 25.50 mA setting V <sub>X1</sub> to V <sub>X3</sub> = 1 V IMX1 = I <sub>X1</sub> to I <sub>X3</sub>	24.22	25.50	26.78	mA	*1
Output current (2)	IMX2	At 1 mA setting V <sub>X1</sub> to V <sub>X3</sub> = 1 V IMX2 = I <sub>X1</sub> to I <sub>X3</sub>	0.95	1.00	1.05	mA	*1
Current step	IMXSTEP	IMAX[2:0] = 011 setting	0	100	200	μA	—
Off leak current	IMXOFF	OFF setting V <sub>X1</sub> to V <sub>X3</sub> = 4.5 V IMXOFF = I <sub>X1</sub> to I <sub>X3</sub>	—	—	1	μA	—
Error between channels	IMXCH	At 12.8 mA setting Current error between each channel and the median of X1 to 3	- 5	—	5	%	—
<b>Overvoltage detection</b>							
Overvoltage detection voltage	VOV	Charge pump DC/DC overvoltage detection	5.3	5.5	5.7	V	—
<b>Step-up mode switch of charge pump</b>							
Step-up mode switch voltage of charge pump	VLD1	X1 to 3 pin voltage at the time when the step-up mode switch of charge pump changes	—	0.35	0.40	V	—
<b>Minimum voltage at which LED driver can keep constant current value</b>							
Minimum voltage at which LED driver can keep constant current value	VLD2	IMAX[2:0] = 011, 95% LED current value at the time when X1 to 3 pin voltage is set to 1V. Minimum value of X1 to 3 pin voltage	—	0.20	0.35	V	—

Note)\*1 : The specified values are the values in case that a recommended component (ERJ2RHD393X) is connected to IREF pin.

**ELECTRICAL CHARACTERISTICS (continued)**

$V_B = 3.6\text{ V}$ ,  $V_{DD} = 1.85\text{ V}$

Note)  $T_a = 25\text{ }^\circ\text{C} \pm 2\text{ }^\circ\text{C}$  unless otherwise specified.

Parameter	Symbol	Condition	Limits			Unit	Note
			Min	Typ	Max		
<b>SLASEL</b>							
High-level input voltage range	VIH1	High-level recognition voltage	$0.7 \times V_{DD}$	—	$V_{DD} + 0.3$	V	—
Low-level input voltage range	VIL1	Low-level recognition voltage	-0.3	—	$0.3 \times V_{DD}$	V	—
High-level input current	IIH1	$V_{SLASEL} = 3.6\text{ V}$	—	0	1	$\mu\text{A}$	—
Low-level input current	IIL1	$V_{SLASEL} = 0\text{ V}$	—	0	1	$\mu\text{A}$	—
<b>CLKIO</b>							
High-level input voltage range	VIH2	High-level recognition voltage (at external clock input mode)	$0.7 \times V_{DD}$	—	$V_{DD} + 0.3$	V	—
Low-level input voltage range	VIL2	Low-level recognition voltage (at external clock input mode)	-0.3	—	$0.3 \times V_{DD}$	V	—
Pin pull-down resistance	RPD2	—	0.4	0.8	1.6	$\text{M}\Omega$	—
High-level input voltage	VOH2	$I_{CLKIO} = -1\text{ mA}$ (at external clock output mode)	$0.8 \times V_{DD}$	—	$V_{DD} + 0.3$	V	—
Low-level input voltage	VOL2	$I_{CLKIO} = 1\text{ mA}$ (at external clock output mode)	-0.3	—	$0.2 \times V_{DD}$	V	—
<b>NRST</b>							
High-level input voltage range	VIH3	High-level recognition voltage	1.5	—	$V_B + 0.3$	V	—
Low-level input voltage range	VIL3	Low-level recognition voltage	-0.3	—	0.6	V	—
High-level input current	IIH3	$V_{NRST} = 3.6\text{ V}$	—	0	1	$\mu\text{A}$	—
Low-level input current	IIL3	$V_{NRST} = 0\text{ V}$	—	0	1	$\mu\text{A}$	—
<b>INT</b>							
ON resistance	RINTON	$I_{INT} = 5\text{ mA}$	—	—	50	$\Omega$	—

**ELECTRICAL CHARACTERISTICS (continued)**

VB = 3.6 V, VDD = 1.85 V

Note) Ta = 25 °C ± 2 °C unless otherwise specified.

Parameter	Symbol	Condition	Limits			Unit	Note
			Min	Typ	Max		
<b>I<sup>2</sup>C bus (Internal I/O stage characteristics)</b>							
Low-level input voltage	VIH4	Voltage which recognized that SDA and SCL are Low-level	0.7 × VDD	—	VDD + 0.5, 6.0	V	*2,3
High-level input voltage	VIL4	Voltage which recognized that SDA and SCL are High-level	—	—	0.3 × VDD	V	*3
Low-level output voltage 1	VOL41	VDD > 2 V ISDA = 3 mA	0	—	0.4	V	—
Low-level output voltage 2	VOL42	VDD < 2 V ISDA = 3 mA	0	—	0.2 × VDD	V	—
Input current each I/O pin	Ii	V <sub>SCL</sub> , V <sub>SDA</sub> = 0.17 V ~ 2.88 V	-10	0	10	μA	—
SCL clock frequency	f <sub>SCL</sub>	—	—	—	400	kHz	—
<b>I<sup>2</sup>C bus (Internal I/O stage characteristics)</b>							
Hysteresis of Schmitt trigger input 1	Vhys1	Hysteresis of SDA, SCL VDD > 2 V	0.05 × VDD	—	—	V	*4 *5
Hysteresis of Schmitt trigger input 2	Vhys2	Hysteresis of SDA, SCL VDD < 2 V	0.1 × VDD	—	—	V	*4 *5
Output fall time from VIHmin to VILmax	Tof	Bus capacitance : 10 pF to 400pF IP ≤ 6 mA (VOLmax = 0.6 V) IP : Max. sink current	20 + 0.1 × Cb	—	250	ns	*4 *5
Pulse width of spikes which must be suppressed by the input filter	Tsp	—	0	—	50	ns	*4 *5
Capacitance for each I/O pin	Ci	—	—	—	10	pF	*4 *5

Note) \*2 : The maximum value of High-level input voltage range is the voltage which is the lower of (VDD + 0.5 V) or 6.0 V.

\*3 : The input threshold voltage of I<sup>2</sup>C bus (Vth) is linked to VDD (I<sup>2</sup>C bus I/O stage supply voltage).

In case the pull-up voltage is not VDD, the threshold voltage (Vth) is fixed to ((VDD / 2) ± (Schmitt width) / 2) and High-level, Low-level of input voltage are not specified. In this case, pay attention to Low-level (max.) value (VILMAX). It is recommended that the pull-up voltage of I<sup>2</sup>C bus is set to the I<sup>2</sup>C bus I/O stage supply voltage (VDD).

\*4 : The timing of Fast-mode Plus devices in I<sup>2</sup>C-bus is specified in Page.19. All values referred to VIHMIN and VILMAX level.

\*5 : These are values checked by design but not production tested.



**ELECTRICAL CHARACTERISTICS (continued)**

VB = 3.6 V, VDD = 1.85 V

Note) Ta = 25 °C ± 2 °C unless otherwise specified.

Parameter	Symbol	Condition	Limits			Unit	Note
			Min	Typ	Max		
<b>I<sup>2</sup>C bus (Bus line specifications)</b>							
Hold time (repeated) START condition	t <sub>HD:STA</sub>	The first clock pulse is generated after t <sub>HD:STA</sub> .	0.6	—	—	μs	*4 *5
Low period of the SCL clock	t <sub>LOW</sub>	—	1.3	—	—	μs	*4 *5
High period of the SCL clock	t <sub>HIGH</sub>	—	0.6	—	—	μs	*4 *5
Set-up time for a repeat START condition	t <sub>SU:STA</sub>	—	0.6	—	—	μs	*4 *5
Data hold time	t <sub>HD:DAT</sub>	—	0	—	—	μs	*4 *5
Data set-up time	t <sub>SU:DAT</sub>	—	100	—	—	ns	*4 *5
Rise time of both SDA and SCL signals	tr	—	20 + 0.1×Cb	—	300	ns	*4 *5
Fall time of both SDA and SCL signals	tf	—	20 + 0.1×Cb	—	300	ns	*4 *5
Set-up time of STOP condition	t <sub>SU:STO</sub>	—	0.6	—	—	μs	*4 *5
Bus free time between STOP and START condition	t <sub>BUF</sub>	—	1.3	—	—	μs	*4 *5
Capacitive load for each bus line	C <sub>b</sub>	—	—	—	400	pF	*4 *5
Data valid time	t <sub>VD:DAT</sub>	—	—	—	0.9	μs	*4 *5
Data valid acknowledge	t <sub>VD:ACK</sub>	—	—	—	0.9	μs	*4 *5
Noise margin at the Low-level for each connected device	V <sub>aL</sub>	—	0.1 × VDD	—	—	V	*4 *5
Noise margin at the High-level for each connected device	V <sub>aH</sub>	—	0.2 × VDD	—	—	V	*4 *5

Note) \*4 : The timing of Fast-mode Plus devices in I<sup>2</sup>C-bus is specified in Page.19. All values referred to V<sub>IHMIN</sub> and V<sub>ILMAX</sub> level.

\*5 : These are values checked by design but not production tested.

**ELECTRICAL CHARACTERISTICS (continued)**

VB = 3.6 V, VDD = 1.85 V

Note) Ta = 25 °C ± 2 °C unless otherwise specified.

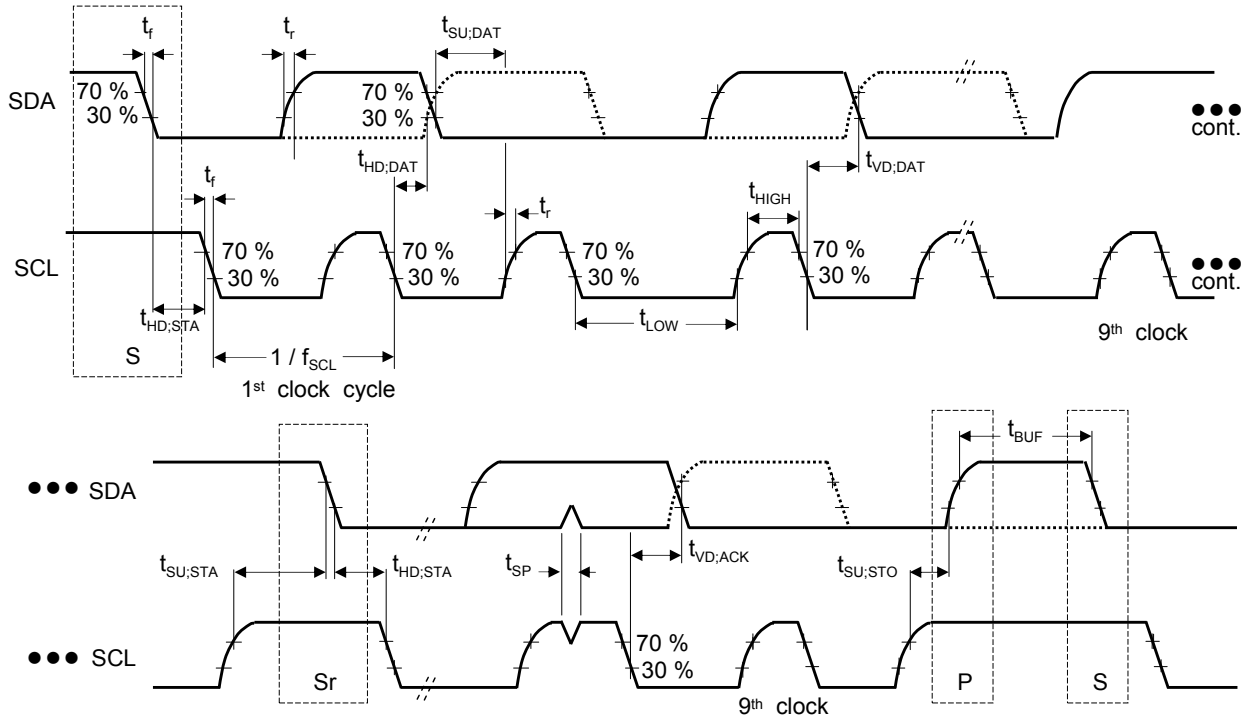

$V_{ILMAX} = 0.3 V_{DD}$

$V_{IHMIN} = 0.7 V_{DD}$

- S : START condition
- Sr : Repeat START condition
- P : STOP condition

**PIN CONFIGURATION**

Top View

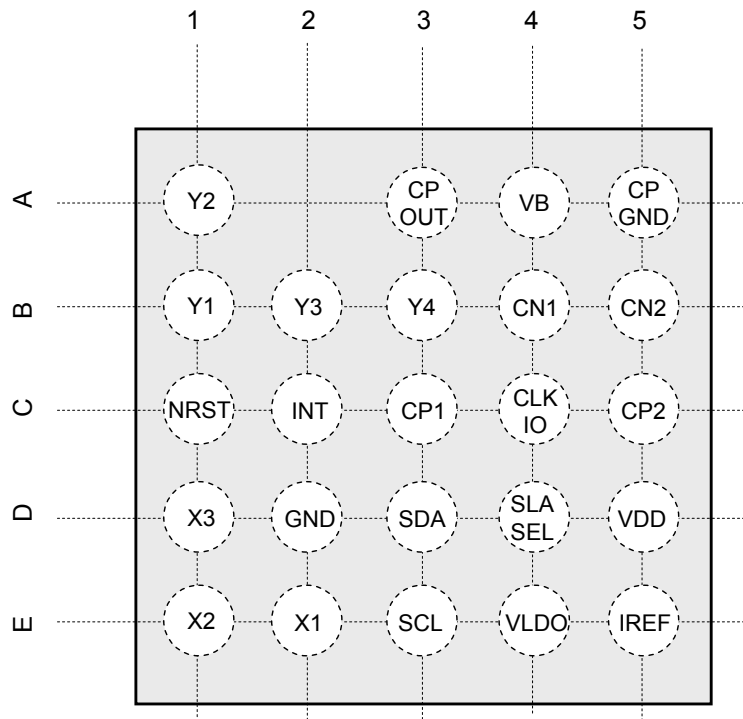

**PIN FUNCTIONS**

Pin No.	Pin name	Type	Description	Pin processing at unused
E3(1)	SCL	Input	I <sup>2</sup> C interface clock input pin	(Must be connected) *1
D3(2)	SDA	Input/Output	I <sup>2</sup> C interface data input / output pin	(Must be connected) *1
D4(3)	SLASEL	Input	I <sup>2</sup> C interface slave address selection pin	(Must be connected) *1
D5(4)	VDD	Input	Power supply pin for interface	(Must be connected) *1
C1(5)	NRST	Input	Reset input pin	(Must be connected) *1
C2(6)	INT	Output	Interrupt output pin	Open
C4(7)	CLKIO	Input/Output	Clock input/output and LED lighting external synchronous input pin	Open
D2(8) A5(22)	GND CPGND	Ground	Ground pin	(Must be connected) *1
E2(9)	X1	Output	Constant current circuit, PWM control output pin Connected to 1st row of matrix LED	Open
E1(10)	X2	Output	Constant current circuit, PWM control output pin Connected to 2nd row of matrix LED	Open
D1(11)	X3	Output	Constant current circuit, PWM control output pin Connected to 3rd row of matrix LED	Open
B1(12)	Y1	Output	Control switch pin for matrix driver Connected to A column of matrix LED	Open
A1(13)	Y2	Output	Control switch pin for matrix driver Connected to B column of matrix LED	Open
B2(14)	Y3	Output	Control switch pin for matrix driver Connected to C column of matrix LED	Open
B3(15)	Y4	Output	Control switch pin for matrix driver Connected to D column of matrix LED	Open
A3(16)	CPOUT	Output	Charge pump output pin / Power supply pin for matrix driver	(Must be connected) *1
A4(17)	VB	Power supply	Power supply pin	(Must be connected) *1
C3(18)	CP1	Output	Capacitor connection pin for charge pump	Open
B4(19)	CN1	Output	Capacitor connection pin for charge pump	Open
C5(20)	CP2	Output	Capacitor connection pin for charge pump	Open
B5(21)	CN2	Output	Capacitor connection pin for charge pump	Open
E5(23)	IREF	Output	Resistor connection pin for constant current setup	(Must be connected) *1
E4(24)	VLDO	Output	Power supply pin for internal circuits	(Must be connected) *1

Note) \*1 : This terminal is required pin when using this LSI. This terminal must be connected.

**FUNCTIONAL BLOCK DIAGRAM**

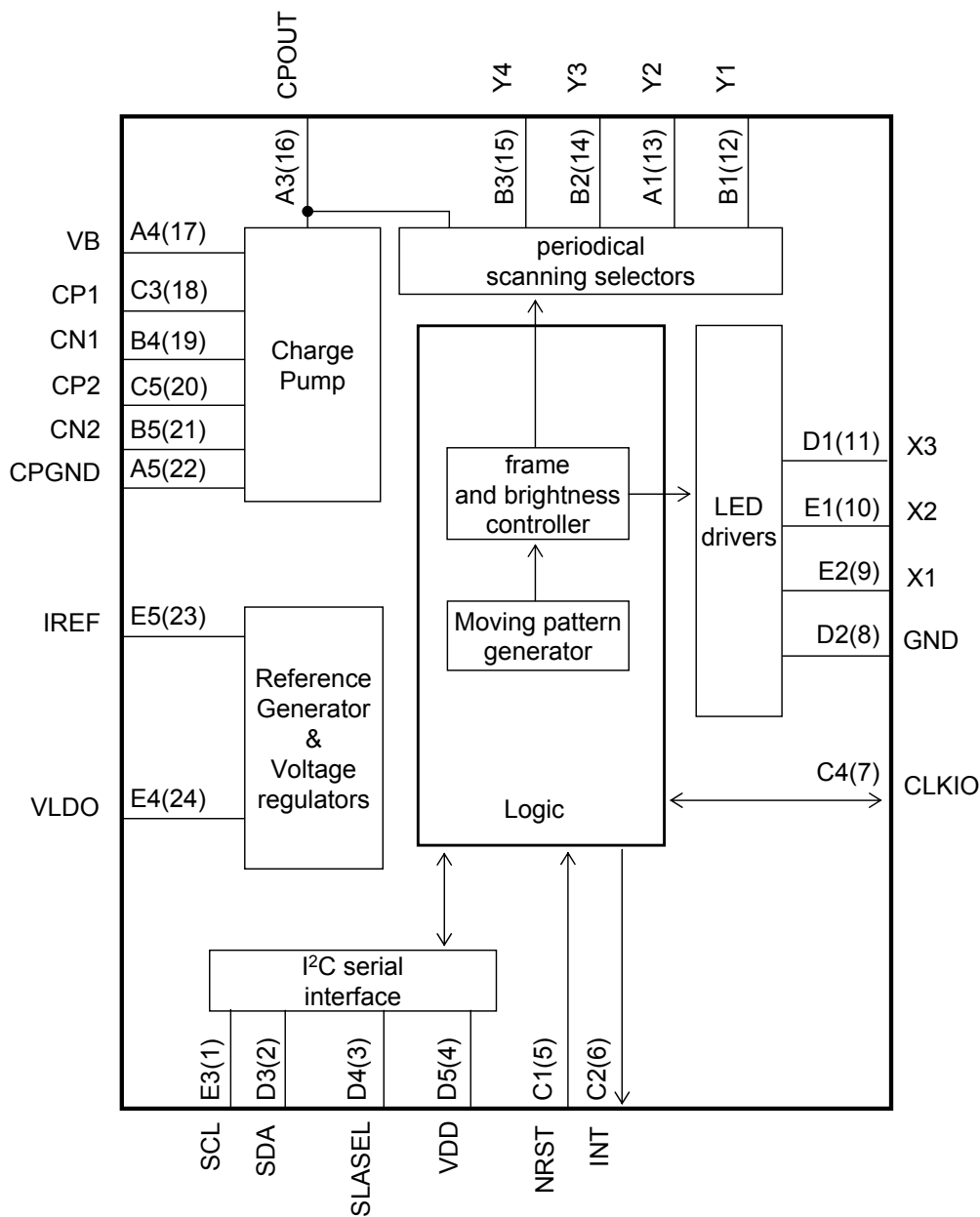

Note) This block diagram is for explaining functions.  
 Part of the block diagram may be omitted, or it may be simplified.



## OPERATION

### 1. Power-on / Power-off sequence control

#### 1.1 Power ON

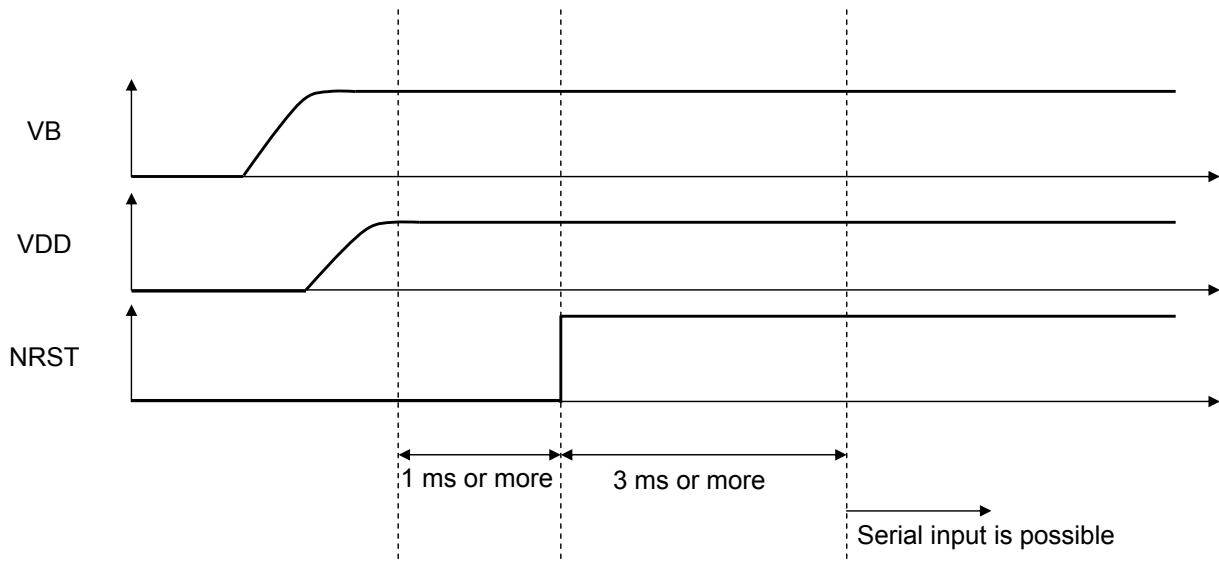

Note) Even if the power-on timing of VDD is the same as the rising timing of VB, there is no problem unless VDD voltage exceeds VB voltage.

#### 1.2 Power OFF

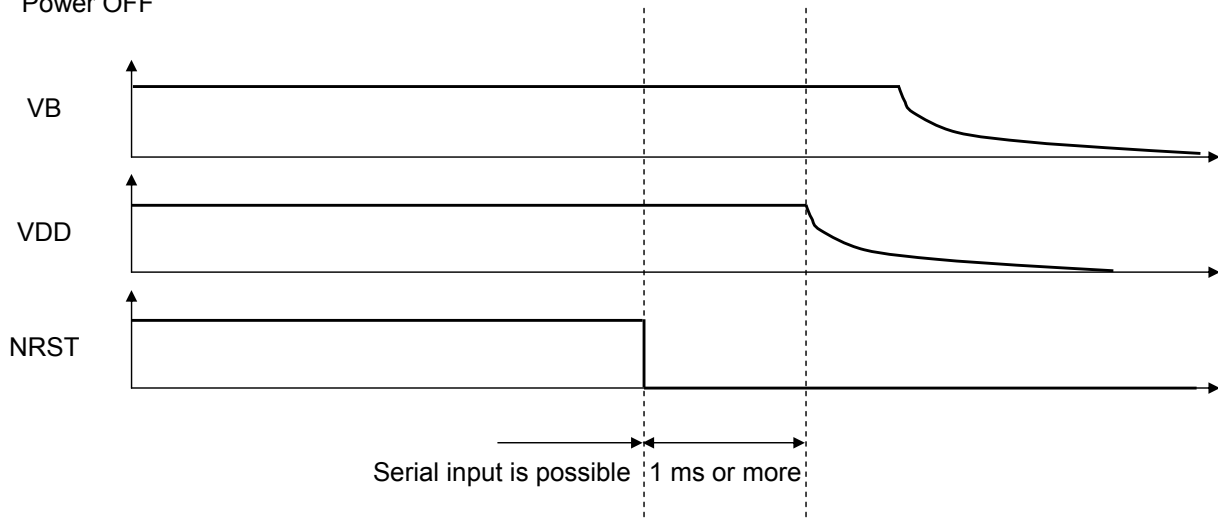

Note) Even if the power-off timing of VDD is the same as the falling timing of VB, there is no problem unless VDD voltage exceeds VB voltage.

**OPERATION (continued)**

**2. Register map**

Sub Address	R/W	Register Name	Default	Data								
				D7	D6	D5	D4	D3	D2	D1	D0	
00h	W	SRESET	00h	—	—	—	—	—	—	—	—	SRESET
01h	R/W	POWERCNT	00h	—	—	—	CPRET MODE	CPCLK SEL20	CPCLK SEL15	OSCEN	—	CPSW
02h	W	LEDMODE	00h	INFON	INFTIME[2:0]			SEQON	—	SEQNUM[1:0]		
03h	R	STATE CHANGE	01h	—	—	—	CPERR	CP20	CP15	VB	—	CPOFF
04h	R/W	STATE FORCE	00h	RETURN VB	ERRMSK	ERRCLR	ERRSTOP	FCP20	FCP15	FVB	—	FCPOFF
05h	R/W	VDETLED CNT	00h	—	—	—	—	VDET3 EN	VDET2 EN	VDET1 EN	—	VDETMX
06h	R/W	MTXON	60h	IMAX[2:0]			MTX DETTM	MTX CPMD	MTXTIME[1:0]			MTXON
07h	W	IOCNT	00h	—	CTLGAIN[2:0]			—	IOEN	CLKDIR	—	EXTPWM
08h	W	CONST	00h	Y4CONST	Y3CONST	Y2CONST	Y1CONST	—	X3CONST	X2CONST	—	X1CONST
09h	W	INTSEL	00h	—	RSTCNT	—	—	—	—	—	—	INTSEL
0Ah	R	INT1	00h	SLPINTC2	SLPINTC1	SLPINTB3	SLPINTB2	SLPINTB1	SLPINTA3	SLPINTA2	—	SLPINTA1
0Bh	R	INT2	00h	SDET	VBDET	FUNCINT	CNTINT	SLPINTD3	SLPINTD2	SLPINTD1	—	SLPINTC3
0Ch	W	INTCLR1	00h	SLPINTC2 CLR	SLPINTC1 CLR	SLPINTB3 CLR	SLPINTB2 CLR	SLPINTB1 CLR	SLPINTA3 CLR	SLPINTA2 CLR	—	SLPINTA1 CLR
0Dh	W	INTCLR2	00h	—	VBDET CLR	FUNCINT CLR	CNTINT CLR	SLPINTD3 CLR	SLPINTD2 CLR	SLPINTD1 CLR	—	SLPINTC3 CLR
0Eh	W	INTMSK1	00h	SLPINTC2 MSK	SLPINTC1 MSK	SLPINTB3 MSK	SLPINTB2 MSK	SLPINTB1 MSK	SLPINTA3 MSK	SLPINTA2 MSK	—	SLPINTA1 MSK
0Fh	R/W	INTMSK2	00h	SDET MSK	VBDET MSK	FUNCINT MSK	CNTINT MSK	SLPINTD3 MSK	SLPINTD2 MSK	SLPINTD1 MSK	—	SLPINTC3 MSK

Note) Read value of "—" (the blanks) is [0] in the register map.

**OPERATION (continued)**

**2. Register map (continued)**

Sub Address	R/W	Register Name	Default	Data							
				D7	D6	D5	D4	D3	D2	D1	D0
10h	R/W	LEDON1	00h	—	B3ON	B2ON	B1ON	—	A3ON	A2ON	A1ON
11h	R/W	LEDON2	00h	—	D3ON	D2ON	D1ON	—	C3ON	C2ON	C1ON
12h	R/W	FADE1	00h	—	FADEB3	FADEB2	FADEB1	—	FADEA3	FADEA2	FADEA1
13h	R/W	FADE2	00h	—	FADED3	FADED2	FADED1	—	FADEC3	FADEC2	FADEC1
14h	R/W	FF1	00h	—	FFB3	FFB2	FFB1	—	FFA3	FFA2	FFA1
15h	R/W	FF2	00h	—	FFD3	FFD2	FFD1	—	FFC3	FFC2	FFC1
16h	R/W	ACT1	00h	ACTINV	ACTB3	ACTB2	ACTB1	—	ACTA3	ACTA2	ACTA1
17h	R/W	ACT2	00h	ACTON	ACTD3	ACTD2	ACTD1	—	ACTC3	ACTC2	ACTC1
18h	R/W	COUNT1	00h	COUNTB1[1:0]		COUNTA3[1:0]		COUNTA2[1:0]		COUNTA1[1:0]	
19h	R/W	COUNT2	00h	COUNTC2[1:0]		COUNTC1[1:0]		COUNTB3[1:0]		COUNTB2[1:0]	
1Ah	R/W	COUNT3	00h	COUNTD3[1:0]		COUNTD2[1:0]		COUNTD1[1:0]		COUNTC3[1:0]	
1Bh	R	LSIVER	01h	—	—	—	—	—	LSIVER[2:0]		

Note) Read value of "—" (the blanks) is [0] in the register map.

**OPERATION (continued)**

**2. Register map (continued)**

Sub Address	R/W	Register Name	Default	Data							
				D7	D6	D5	D4	D3	D2	D1	D0
20h	R/W	SEQA1	00h	—	—	—	—	SEQA14	SEQA13	SEQA12	SEQA11
21h	R/W	SEQA2	00h	—	—	—	—	SEQA24	SEQA23	SEQA22	SEQA21
22h	R/W	SEQA3	00h	—	—	—	—	SEQA34	SEQA33	SEQA32	SEQA31
23h	R/W	SEQB1	00h	—	—	—	—	SEQB14	SEQB13	SEQB12	SEQB11
24h	R/W	SEQB2	00h	—	—	—	—	SEQB24	SEQB23	SEQB22	SEQB21
25h	R/W	SEQB3	00h	—	—	—	—	SEQB34	SEQB33	SEQB32	SEQB31
26h	R/W	SEQC1	00h	—	—	—	—	SEQC14	SEQC13	SEQC12	SEQC11
27h	R/W	SEQC2	00h	—	—	—	—	SEQC24	SEQC23	SEQC22	SEQC21
28h	R/W	SEQC3	00h	—	—	—	—	SEQC34	SEQC33	SEQC32	SEQC31
29h	R/W	SEQD1	00h	—	—	—	—	SEQD14	SEQD13	SEQD12	SEQD11
2Ah	R/W	SEQD2	00h	—	—	—	—	SEQD24	SEQD23	SEQD22	SEQD21
2Bh	R/W	SEQD3	00h	—	—	—	—	SEQD34	SEQD33	SEQD32	SEQD31

Note) Read value of "—" (the blanks) is [0] in the register map.

**OPERATION (continued)**

**2. Register map (continued)**

Sub Address	R/W	Register Name	Default	Data							
				D7	D6	D5	D4	D3	D2	D1	D0
30h	R/W	A1SET1	00h	BLA1[7:0]							
31h	R/W	A1SET2	00h	TSA1[7:0]							
32h	R/W	A1SET3	00h	DLLCA1	—	—	DLA1[4:0]				
33h	R/W	A2SET1	00h	BLA2[7:0]							
34h	R/W	A2SET2	00h	TSA2[7:0]							
35h	R/W	A2SET3	00h	DLLCA2	—	—	DLA2[4:0]				
36h	R/W	A3SET1	00h	BLA3[7:0]							
37h	R/W	A3SET2	00h	TSA3[7:0]							
38h	R/W	A3SET3	00h	DLLCA3	—	—	DLA3[4:0]				
39h	R/W	B1SET1	00h	BLB1[7:0]							
3Ah	R/W	B1SET2	00h	TSB1[7:0]							
3Bh	R/W	B1SET3	00h	DLLCB1	—	—	DLB1[4:0]				
3Ch	R/W	B2SET1	00h	BLB2[7:0]							
3Dh	R/W	B2SET2	00h	TSB2[7:0]							
3Eh	R/W	B2SET3	00h	DLLCB2	—	—	DLB2[4:0]				
3Fh	R/W	B3SET1	00h	BLB3[7:0]							
40h	R/W	B3SET2	00h	TSB3[7:0]							
41h	R/W	B3SET3	00h	DLLCB3	—	—	DLB3[4:0]				

Note) Read value of "—" (the blanks) is [0] in the register map.



**OPERATION (continued)**

**2. Register map (continued)**

Sub Address	R/W	Register Name	Default	Data							
				D7	D6	D5	D4	D3	D2	D1	D0
42h	R/W	C1SET1	00h	BLC1[7:0]							
43h	R/W	C1SET2	00h	TSC1[7:0]							
44h	R/W	C1SET3	00h	DLLCC1	—	—	DLC1[4:0]				
45h	R/W	C2SET1	00h	BLC2[7:0]							
46h	R/W	C2SET2	00h	TSC2[7:0]							
47h	R/W	C2SET3	00h	DLLCC2	—	—	DLC2[4:0]				
48h	R/W	C3SET1	00h	BLC3[7:0]							
49h	R/W	C3SET2	00h	TSC3[7:0]							
4Ah	R/W	C3SET3	00h	DLLCC3	—	—	DLC3[4:0]				
4Bh	R/W	D1SET1	00h	BLD1[7:0]							
4Ch	R/W	D1SET2	00h	TSD1[7:0]							
4Dh	R/W	D1SET3	00h	DLLCD1	—	—	DLD1[4:0]				
4Eh	R/W	D2SET1	00h	BLD2[7:0]							
4Fh	R/W	D2SET2	00h	TSD2[7:0]							
50h	R/W	D2SET3	00h	DLLCD2	—	—	DLD2[4:0]				
51h	R/W	D3SET1	00h	BLD3[7:0]							
52h	R/W	D3SET2	00h	TSD3[7:0]							
53h	R/W	D3SET3	00h	DLLCD3	—	—	DLD3[4:0]				

Note) Read value of "—" (the blanks) is [0] in the register map.

**OPERATION (continued)**

**3. I<sup>2</sup>C-bus interface**

3.1 Basic Rules

- This LSI, I<sup>2</sup>C-bus, is designed to correspond to the Standard-mode (100 kbps) and Fast-mode(400 kbps) devices in the version 03 of NXP's specification. However, it does not correspond to the H<sub>S</sub>-mode (to 3.4 Mbps).
- This LSI will operate as a slave device in the I<sup>2</sup>C-bus system. This LSI will not operate as a master device.
- The program operation check of this LSI has not been conducted on the multi-master bus system and the mix-speed bus system, yet. The connected confirmation of this LSI to the CBUS receiver also has not been checked. Please confirm with our company if it will be used in these mode systems.
- The I<sup>2</sup>C is the brand of NXP.

3.2. START and STOP conditions

A High to Low transition on the SDA line while SCL is High is one such unique case. This situation indicates START condition. A Low to High transition on the SDA line while SCL is High defines STOP condition. START and STOP conditions are always generated by the master. After START condition occur, the bus will be busy. The bus is considered to be free again a certain time after the STOP condition.

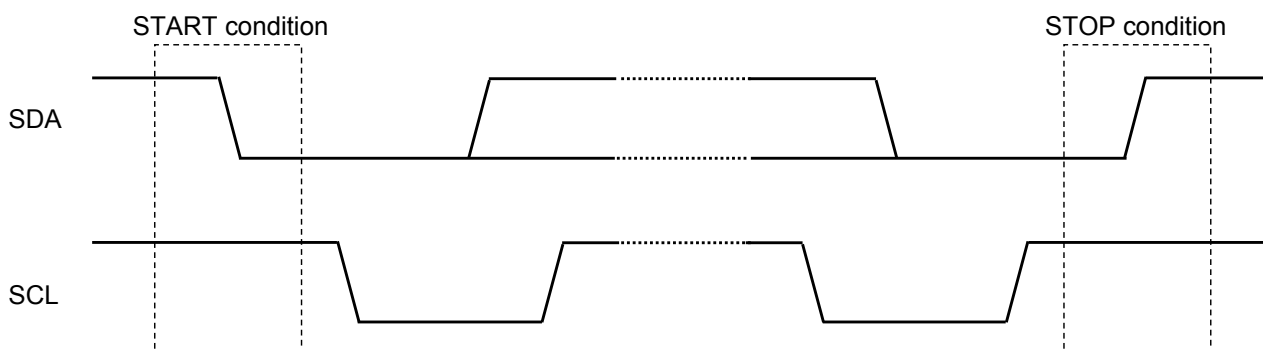

3.3. Transferring Data

Every byte put on the SDA line must be 8-bits long. The number of bytes that can be transmitted per transfer is unrestricted. Each byte has to be followed by an acknowledge bit. Data is transferred with the most significant bit (MSB) first.

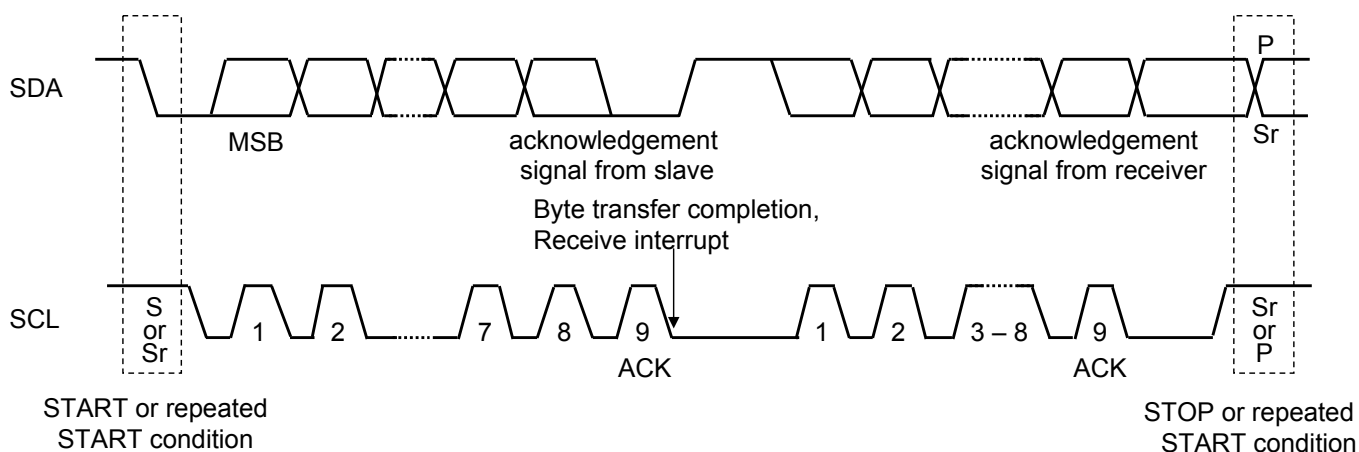

**OPERATION (continued)**

**3. I<sup>2</sup>C-bus interface (continued)**

3.4 Data format

It is possible to select slave address by switching SLASEL pin from Low-level to High-level.  
 The slave address of this LSI is as follows.

SLASEL	Slave address
Low	0110100X
High	0110101X

Write mode

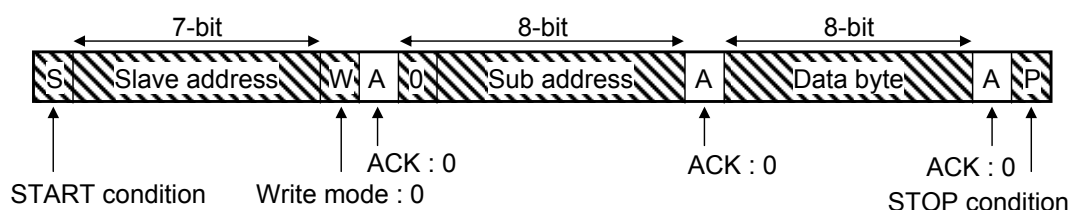

When MSB of sub address (8-bit) is "0", the sub address is not incremented automatically.  
 By transmitting data bytes continuously, the next data bytes are written into the same sub address. by transmitting data byte continuously

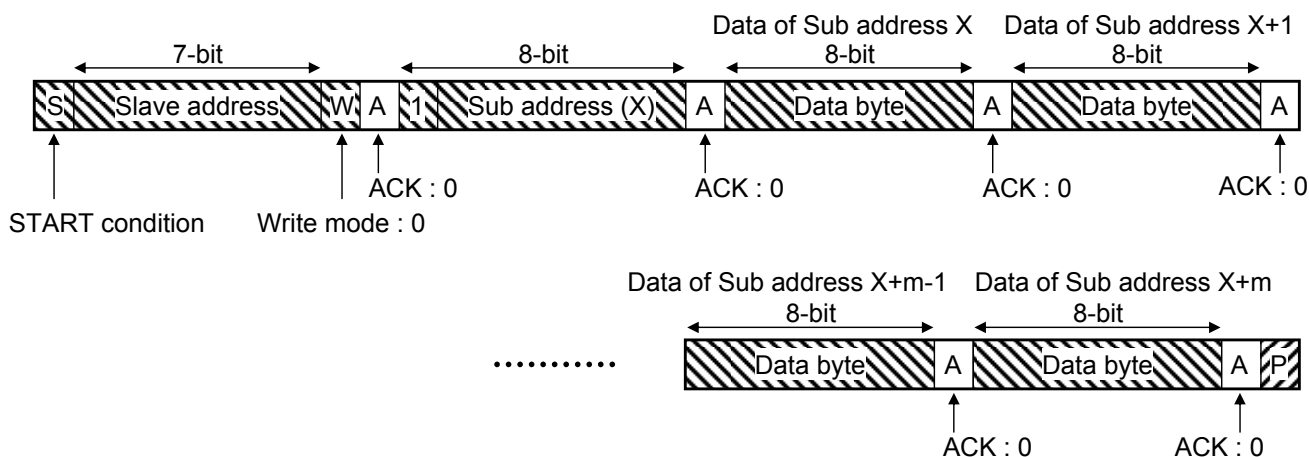

Write mode (Auto increment mode)

When MSB of sub address (8-bit) is "1", auto increment mode is defined.  
 By transmitting data bytes continuously, the data bytes are written into continuous sub address.  
 The sub address is incremented automatically.



 : Data transmission from Master  
 : Data transmission from Slave

**OPERATION (continued)**

**3. I<sup>2</sup>C-bus interface (continued)**

3.4 Data format (continued)

Read mode (In case sub address is not specified)

When the data is read without specifying sub address 8-bit, it is possible to read the value of sub address specified at adjacent write mode.

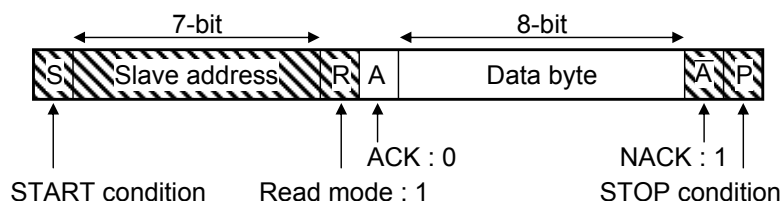

Read mode (In case sub address is specified)

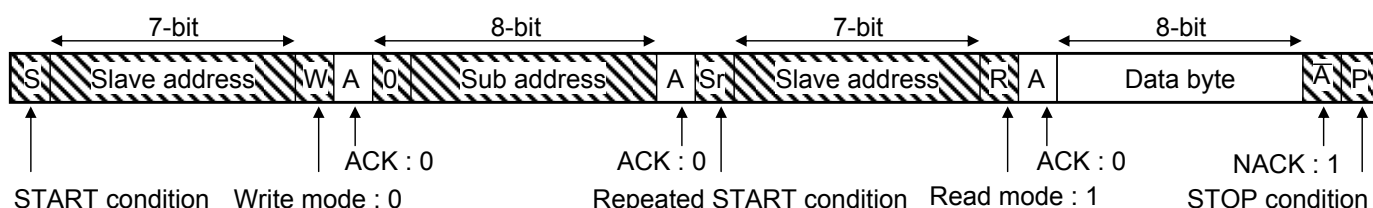

When MSB of sub address (8-bit) is "0", sub address is incremented automatically. Data byte of specified sub address is read repeatedly continuously until STOP condition is received.

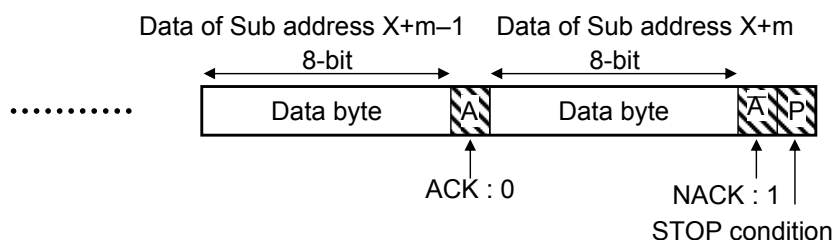
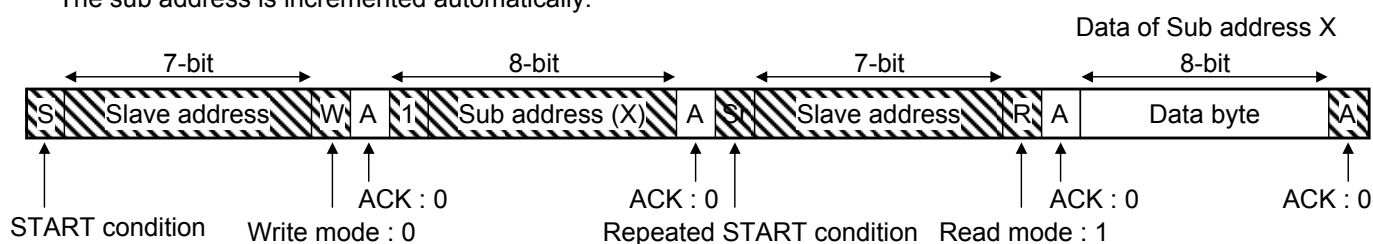

Read mode (Auto increment mode in case sub address is specified)

When MSB of sub address (8-bit) is "1", auto increment mode is specified. Until STOP condition is received, data byte of sub address incremented automatically by specified sub address can be read continuously. The sub address is incremented automatically.



 : Data transmission from Master  
 : Data transmission from Slave

**OPERATION (continued)**

**4. Signal distribution diagram**

Distribution diagram of power supply system

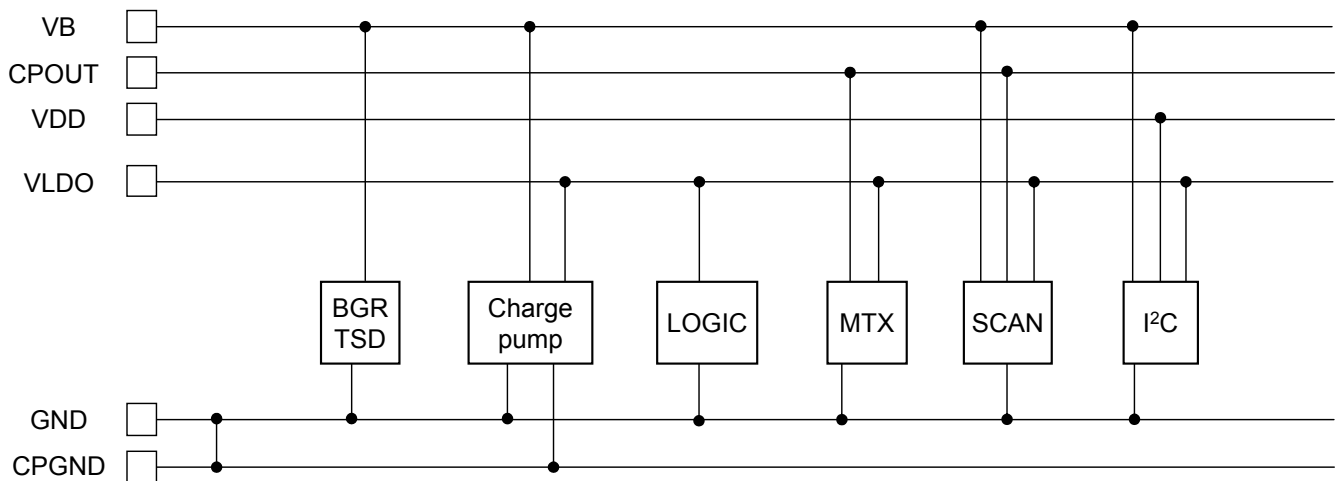

Distribution diagram of control / clock system

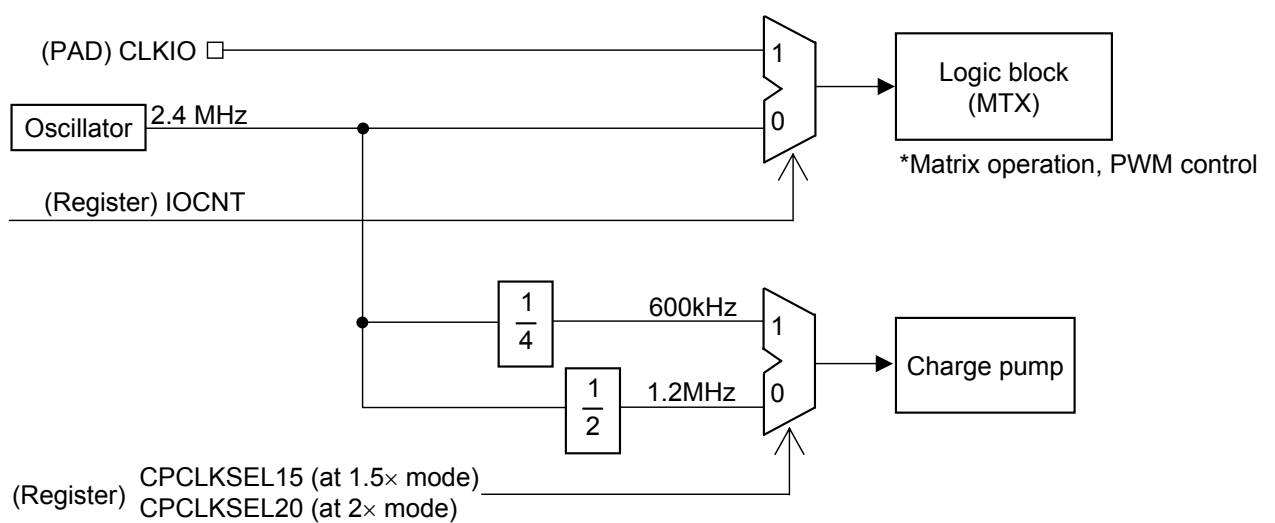



**PACKAGE INFORMATION ( Reference Data )**

Package Code : UBGA024-W-2525AEL

Unit:mm

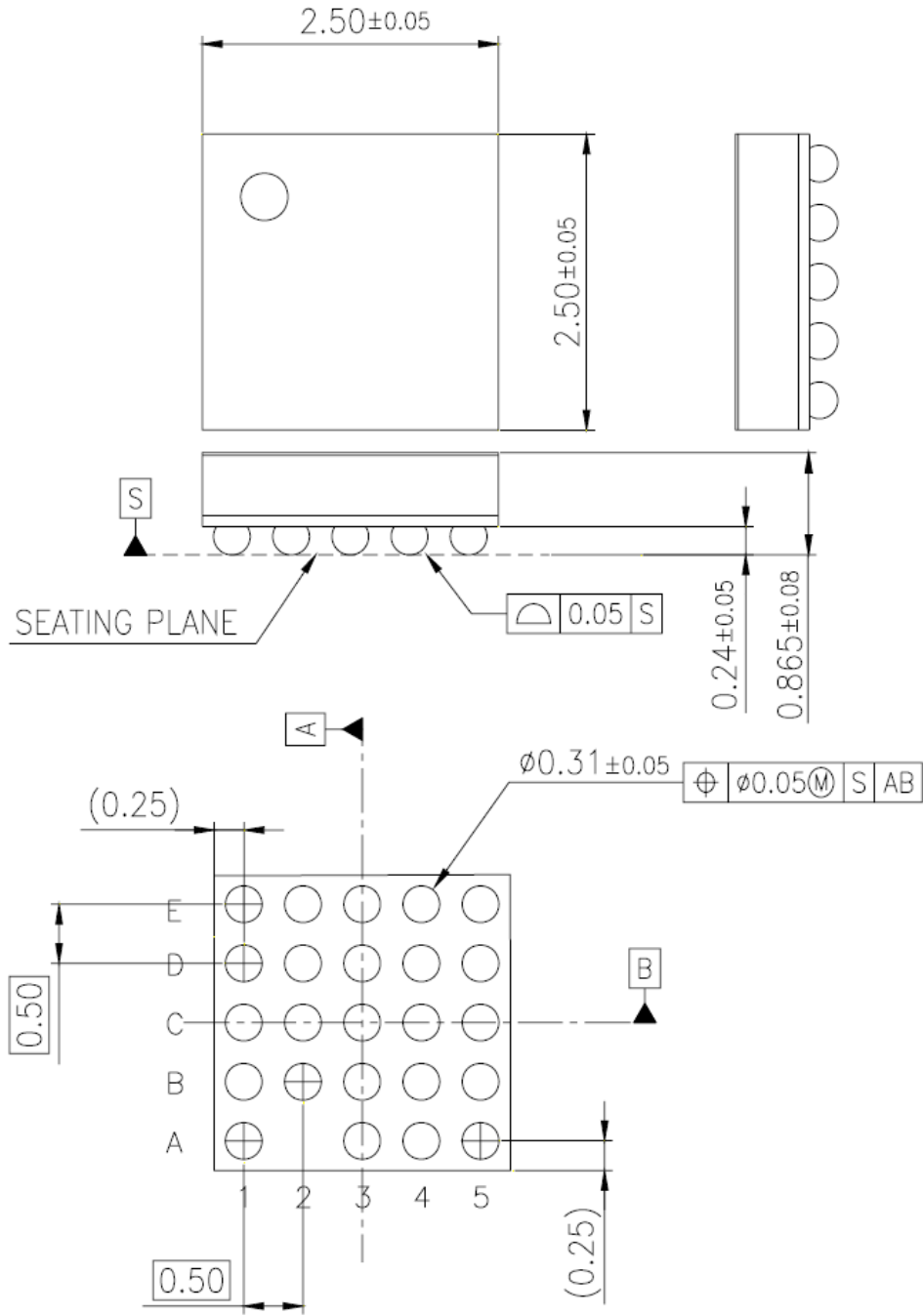

Body Material	: Br / Sb Free Epoxy Resin
Reroute Material	: Cu
Bump	: SnAgCu

## IMPORTANT NOTICE

1. When using the LSI for new models, verify the safety including the long-term reliability for each product.
2. When the application system is designed by using this LSI, please confirm the notes in this book.  
Please read the notes to descriptions and the usage notes in the book.
3. This LSI is intended to be used for general electronic equipment.  
Consult our sales staff in advance for information on the following applications: Special applications in which exceptional quality and reliability are required, or if the failure or malfunction of this LSI may directly jeopardize life or harm the human body.  
Any applications other than the standard applications intended.
  - (1) Space appliance (such as artificial satellite, and rocket)
  - (2) Traffic control equipment (such as for automobile, airplane, train, and ship)
  - (3) Medical equipment for life support
  - (4) Submarine transponder
  - (5) Control equipment for power plant
  - (6) Disaster prevention and security device
  - (7) Weapon
  - (8) Others : Applications of which reliability equivalent to (1) to (7) is requiredOur company shall not be held responsible for any damage incurred as a result of or in connection with the LSI being used for any special application, unless our company agrees to the use of such special application.
4. This LSI is neither designed nor intended for use in automotive applications or environments unless the specific product is designated by our company as compliant with the ISO/TS 16949 requirements.  
Our company shall not be held responsible for any damage incurred by customers or any third party as a result of or in connection with the LSI being used in automotive application, unless our company agrees to such application in this book.
5. Please use this product in compliance with all applicable laws and regulations that regulate the inclusion or use of controlled substances, including without limitation, the EU RoHS Directive. Our company shall not be held responsible for any damage incurred as a result of our LSI being used by our customers, not complying with the applicable laws and regulations.
6. Pay attention to the direction of LSI. When mounting it in the wrong direction onto the PCB (printed-circuit-board), it might emit smoke or ignite.
7. Pay attention in the PCB (printed-circuit-board) pattern layout in order to prevent damage due to short circuit between pins. In addition, refer to the Pin Description for the pin configuration.
8. Perform visual inspection on the PCB before applying power, otherwise damage might happen due to problems such as solder-bridge between the pins of the semiconductor device. Also, perform full technical verification on the assembly quality, because the same damage possibly can happen due to conductive substances, such as solder ball, that adhere to the LSI during transportation.
9. Take notice in the use of this product that it might be damaged or occasionally emit smoke when an abnormal state occurs such as output pin-VCC short (Power supply fault), output pin-GND short (Ground fault), or output-to-output-pin short (load short). Safety measures such as installation of fuses are recommended because the extent of the above-mentioned damage and smoke emission will depend on the current capability of the power supply..
10. The protection circuit is for maintaining safety against abnormal operation. Therefore, the protection circuit should not work during normal operation.  
Especially for the thermal protection circuit, if the area of safe operation or the absolute maximum rating is momentarily exceeded due to output pin to VCC short (Power supply fault), or output pin to GND short (Ground fault), the LSI might be damaged before the thermal protection circuit could operate.
11. Unless specified in the product specifications, make sure that negative voltage or excessive voltage are not applied to the pins because the device might be damaged, which could happen due to negative voltage or excessive voltage generated during the ON and OFF timing when the inductive load of a motor coil or actuator coils of optical pick-up is being driven.
12. Verify the risks which might be caused by the malfunctions of external components.
13. Due to the unshielded structure of this LSI, functions and characteristics of the product cannot be guaranteed under the exposure of light. During normal operation or even under testing condition, please ensure that the LSI is not exposed to light.
14. Please ensure that your design does not have metal shield parts touching the chip surface as the surface potential is GND voltage.

## Request for your special attention and precautions in using the technical information and semiconductors described in this book

- (1) If any of the products or technical information described in this book is to be exported or provided to non-residents, the laws and regulations of the exporting country, especially, those with regard to security export control, must be observed.
- (2) The technical information described in this book is intended only to show the main characteristics and application circuit examples of the products. No license is granted in and to any intellectual property right or other right owned by Panasonic Corporation or any other company. Therefore, no responsibility is assumed by our company as to the infringement upon any such right owned by any other company which may arise as a result of the use of technical information de-scribed in this book.
- (3) The products described in this book are intended to be used for general applications (such as office equipment, communications equipment, measuring instruments and household appliances), or for specific applications as expressly stated in this book.  
Please consult with our sales staff in advance for information on the following applications, moreover please exchange documents separately on terms of use etc.: Special applications (such as for in-vehicle equipment, airplanes, aerospace, automotive equipment, traffic signaling equipment, combustion equipment, medical equipment and safety devices) in which exceptional quality and reliability are required, or if the failure or malfunction of the products may directly jeopardize life or harm the human body.  
Unless exchanging documents on terms of use etc. in advance, it is to be understood that our company shall not be held responsible for any damage incurred as a result of or in connection with your using the products described in this book for any special application.
- (4) The products and product specifications described in this book are subject to change without notice for modification and/or improvement. At the final stage of your design, purchasing, or use of the products, therefore, ask for the most up-to-date Product Standards in advance to make sure that the latest specifications satisfy your requirements.
- (5) When designing your equipment, comply with the range of absolute maximum rating and the guaranteed operating conditions (operating power supply voltage and operating environment etc.). Especially, please be careful not to exceed the range of absolute maximum rating on the transient state, such as power-on, power-off and mode-switching. Otherwise, we will not be liable for any defect which may arise later in your equipment.  
Even when the products are used within the guaranteed values, take into the consideration of incidence of break down and failure mode, possible to occur to semiconductor products. Measures on the systems such as redundant design, arresting the spread of fire or preventing glitch are recommended in order to prevent physical injury, fire, social damages, for example, by using the products.
- (6) Comply with the instructions for use in order to prevent breakdown and characteristics change due to external factors (ESD, EOS, thermal stress and mechanical stress) at the time of handling, mounting or at customer's process. We do not guarantee quality for disassembled products or the product re-mounted after removing from the mounting board.  
When using products for which damp-proof packing is required, satisfy the conditions, such as shelf life and the elapsed time since first opening the packages.
- (7) When reselling products described in this book to other companies without our permission and receiving any claim of request from the resale destination, please understand that customers will bear the burden.
- (8) This book may be not reprinted or reproduced whether wholly or partially, without the prior written permission of our company.