



Chipsmall Limited consists of a professional team with an average of over 10 year of expertise in the distribution of electronic components. Based in Hongkong, we have already established firm and mutual-benefit business relationships with customers from,Europe,America and south Asia,supplying obsolete and hard-to-find components to meet their specific needs.

With the principle of “Quality Parts,Customers Priority,Honest Operation,and Considerate Service”,our business mainly focus on the distribution of electronic components. Line cards we deal with include Microchip,ALPS,ROHM,Xilinx,Pulse,ON,Everlight and Freescale. Main products comprise IC,Modules,Potentiometer,IC Socket,Relay,Connector.Our parts cover such applications as commercial,industrial, and automotives areas.

We are looking forward to setting up business relationship with you and hope to provide you with the best service and solution. Let us make a better world for our industry!



## Contact us

Tel: +86-755-8981 8866 Fax: +86-755-8427 6832

Email & Skype: info@chipsmall.com Web: www.chipsmall.com

Address: A1208, Overseas Decoration Building, #122 Zhenhua RD., Futian, Shenzhen, China



Realizing in One IC,  
 PWM Output Open Control by External PWM Signal and  
 PWM Output Loop Control by External DC Voltage and Current Peak Detection.

## 3-Phase Brushless Motor Drive IC

### Features

- Supply voltage range: 6.0 V to 36 V
- Built-in 5-V regulator
- 3-phase 120-deg--energization drive system by 3-Hall-sensor
- Drive control mode is selectable:
  - PWM open control by an external PWM signal (PWM through drive)
  - PWM loop control by external DC voltage and current peak detection. (OFF time fixed current peak detection PWM drive)
- OFF time setting switching function
- Rotation direction switching function
- FG pulse switching function (1FG or 3FG)
- Short-brake/Free-running function
- Built in various protection functions: under voltage lock out (UVLO), thermal protection, motor restricted protection, overcurrent protection and drive output short protection

### Applications

- Driver IC for 3-phase brushless motor

### Package

- 24-pin plastic quad flat non-lead package (QFN type, size: 4 mm × 4 mm)



### Summary

AN44150A is a driver IC for 3-phase brushless motor. The rotor position detection by a 3-Hall-sensor and a 120-deg--energization drive system are adopted. It is selectable the PWM through drive mode or the OFF time fixed current peak detection PWM drive mode. Low power consumption of a motor module is realized, and it contributes to the application expansion of various motor units.

### Application Circuit Example

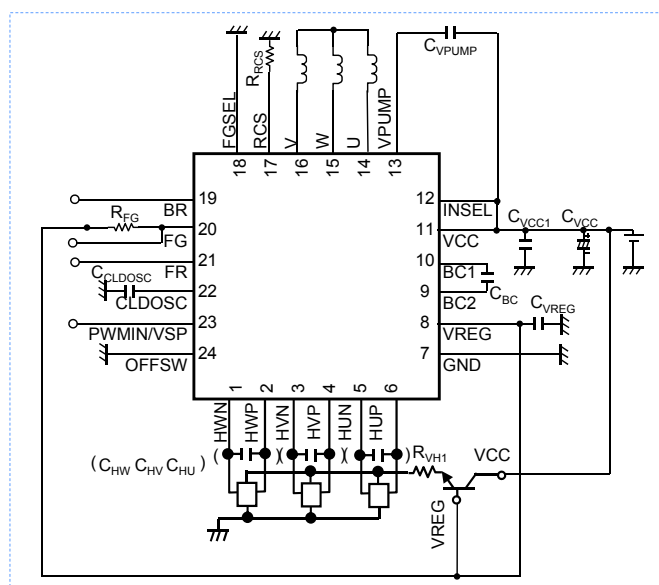

Note: In the above circuit example, It's not that the operation of the volume production is guaranteed. When designing a mass production set, after having conducted an evaluation and verification enough, use it with the customer's responsibility.

### Motor Drive Waveform

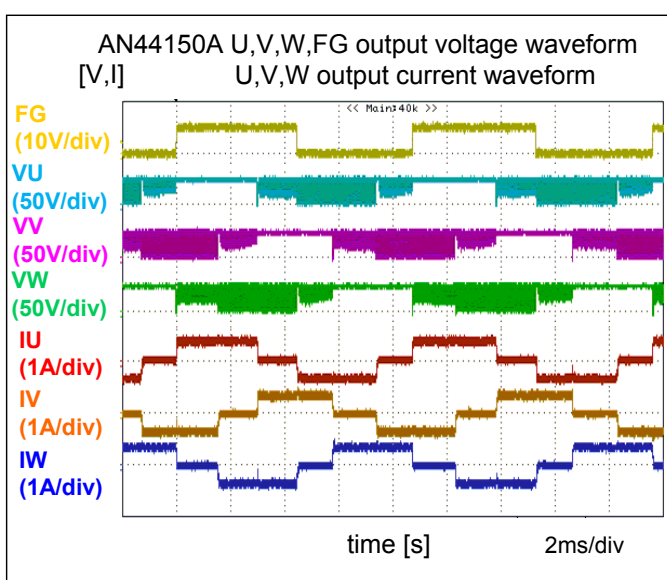

Conditions: PWMIN mode, PWMIN=20kHz, 50%duty  
 $V_{CC} = 24\text{ V}$ ,  $V_{FR} = \text{H}$ , FGSEL=L

**Table of Contents**

■ Feature .....	1
■ Summary .....	1
■ Applications .....	1
■ Package .....	1
■ Application Circuit Example .....	1
■ Motor Drive Waveform .....	1
■ Table of Contents .....	2
■ Absolute Maximum Rating .....	3
■ Rated Power Consumption .....	3
■ Recommended Operating Conditions .....	4
■ Electrical Characteristics .....	5
■ Pin Configuration .....	8
■ Pin Functions .....	8
■ Block Diagram .....	9
■ Application Circuit Diagram .....	10
■ Function Pin Table .....	11
■ Protection Function .....	12
■ 3 Phase Drive State Diagram .....	13
■ Functional Explanation .....	14
■ PIN EQUIVALENT CIRCUIT .....	24
■ Safe Operating Area .....	30
■ Package Information .....	31
■ IMPORTANT NOTICE .....	34
■ Usage Notes .....	36



**Absolute Maximum Rating**

Parameter	Symbol	Rating	Unit	Note
Supply voltage	$V_{CC}$	37	V	*1
Output current	$I_U, I_V, I_W$	$\pm 1.5$	A	*1, *4
Operating ambient temperature	$T_{OPR}$	- 40 ~ + 80	°C	*2
Storage temperature	$T_{STG}$	- 55 ~ +150	°C	*2
Input voltage range	$V_{OFFSW}, V_{HUP}, V_{HUN}, V_{HVP}, V_{HVN}, V_{HWP}, V_{HWN}, V_{BR}, V_{FR}, V_{PVMIN/VSP}, V_{FGSEL}$	- 0.3 ~ 6.0	V	—
	$V_{INSEL}$	- 0.3 ~ 37.0	V	—
Output voltage range	$V_U, V_V, V_W$	37	V	*1, *3
	$V_{FG}$	- 0.3 ~ 6.0	V	—
	$V_{VREG}, V_{RCS}, V_{CLDOSC}$	- 0.3 ~ 6.0	V	*3
	$V_{BC1}$	37	V	*3
	$V_{BC2}, V_{PUMP}$	45	V	*3
Input current range	$I_{FG}$	0 ~ 10	mA	—
	$I_{VREG}$	0 ~ -10	mA	*4
ESD tolerance	MM	$\pm 200$	V	—
	HBM	$\pm 2$	kV	—

Notes:

If you give a stress above those listed under absolute maximum ratings, it is possible that permanent damage to the product. These are provisions for stress ratings, it is not guaranteed that functional operation of the device at the value greater than recommended operating range. When exposing to absolute maximum conditions for extended periods, it may affect the reliability of this product.

- \*1: It indicates when using in a range that does not exceed the absolute maximum rating, including the rated power consumption.
- \*2: Except the operating ambient temperature, and the storage temperature, all ratings are for  $T_a = 25\text{ °C}$ .
- \*3: Do not apply external voltage to these pins, and set them not to exceed the rated value even transitional.
- \*4: Do not apply external current to these pins, and set them not to exceed the rated value even transitional.

**Rated Power Consumption**

Package	$\theta_{j-a}$	$\theta_{j-c}$	$P_D (T_a=25\text{°C})$	$P_D (T_a=70\text{°C})$
24 pin Plastic Quad Flat Non-lead Package (QFN type)	57.8°C/W	5.4 °C/W	2163mW	1384mW

Note: For the actual usage, refer to the PD-Ta characteristics diagram in the package specification, follow the supply voltage, load and ambient temperature conditions to ensure that there is enough margin and the thermal design does not exceed the allowable value.

\*1: Glass-epoxy substrate (2 Layers) : 50×50×0.8t (mm) ,thermal via, back heat sink: Dai-pad , Soldered.



**CAUTION**

Although this has limited built-in ESD protection circuit, but permanent damage may occur on it. Therefore, proper ESD precautions are recommended to avoid electrostatic damage to the MOS gates.

**Recommended Operating Conditions**

Parameter	Symbol	Min.	Typ.	Max.	Unit	Note
Supply voltage range	$V_{CC}$	6.0	—	36	V	*1
Input voltage range	$V_{INSEL}$	0	—	$V_{CC}$	V	*1
	$V_{OFFSW}$	0	—	$V_{VREG}$	V	*1
	$V_{FGSEL}$	0	—	$V_{VREG}$	V	*1
	$V_{RCS}$	0	—	$V_{VREG}$	V	*1
	$V_{BR}$	0	—	$V_{VREG}$	V	*1
	$V_{FR}$	0	—	$V_{VREG}$	V	*1
	$V_{PVMIN/VSP}$	0	—	$V_{VREG}$	V	*1
External constants (reference)	$C_{VCC}$	—	47 $\mu$	—	F	*2
	$C_{VCC1}$	—	0.1 $\mu$	—	F	*2
	$C_{VREG}$	—	0.1 $\mu$	—	F	*2
	$C_{BC}$	—	0.01 $\mu$	—	F	*2
	$C_{VPUMP}$	—	0.01 $\mu$	—	F	*2
	$C_{CLDOSC}$	—	0.022 $\mu$	—	F	*2
	$C_{HU}$	—	0.01 $\mu$	—	F	*2
	$C_{HV}$	—	0.01 $\mu$	—	F	*2
	$C_{HW}$	—	0.01 $\mu$	—	F	*2
	$R_{RCS}$	0.16	0.27	—	$\Omega$	*2,*3
	$R_{FG}$	—	51k	—	$\Omega$	*2
	$R_{VH1}$	—	1k	—	$\Omega$	*2

Notes:

- \*1 For the setting range of input control voltage, refer to the Electrical Characteristics, and the Functional Explanation.
- \*2 This value is an example. Operation of mass production set is not guaranteed. Perform enough evaluation and verification on the design of mass production set.
- \*3 A value less than this resistance is prohibited. If you set below this minimum value, there is a possibility that the output current exceeding rated current.

**Electrical Characteristics**

at V<sub>CC</sub>=24V,

Note: T<sub>a</sub> = 25°C±2°C unless otherwise noted.

Parameter	Symbol	Condition	Limits			Unit	Note
			Min	Typ	Max		
<b>Circuit current</b>							
V <sub>CC</sub> current	I <sub>CC1</sub>	—	—	2.4	3.8	mA	
V <sub>CC</sub> current at STBY mode	I <sub>CC2</sub>	at STBY mode	—	350	700	μA	
<b>Power block</b>							
Output on-resistance	R <sub>ONHL</sub>	I = ±1A (High side + Low side) V <sub>CC</sub> =12V	0.7	1.14	1.55	Ω	
Output leak current	I <sub>PL</sub>	—	—	10	50	μA	
Diode forward voltage	V <sub>DI</sub>	I = 1A	—	1	1.6	V	
<b>5V regulator block</b>							
VREG voltage	V <sub>VREG</sub>	—	4.7	5	5.3	V	
Voltage regulation	ΔV <sub>REG1</sub>	V <sub>CC</sub> =6 ~ 36V, I <sub>o</sub> =-5mA	—	20	50	mV	
Load regulation	ΔV <sub>REG2</sub>	I <sub>o</sub> =-5m ~ -10mA	—	50	100	mV	
<b>CLD oscillator circuit</b>							
High level output voltage	V <sub>OHCLD</sub>	Design target value	—	2.5	—	V	*2
Low level output voltage	V <sub>OLCLD</sub>	Design target value	—	0.5	—	V	*2
Amplitude	V <sub>CLD</sub>	—	1.3	2.0	2.7	V <sub>pp</sub>	
External capacitor charge current	I <sub>CLD1</sub>	V <sub>CLD</sub> =1.5V	-17.6	-12	-6.4	μA	
External capacitor discharge current	I <sub>CLD2</sub>	V <sub>CLD</sub> =1.5V	6.4	12	17.6	μA	
Oscillation frequency	F <sub>CLD</sub>	C=0.022μF (Design target value)	—	136	—	Hz	*2
<b>Hall block</b>							
Input bias current	I <sub>HALL</sub>	—	-2	0	2	μA	
Input dynamic range	V <sub>HALL</sub>	—	0	—	V <sub>REG</sub> -1.7	V	
Hysteresis width	V <sub>OVhys</sub>	—	9	20	35	mV	
Hysteresis level: L → H	V <sub>HYS1</sub>	—	3	10	17	mV	
Hysteresis level: H → L	V <sub>HYS2</sub>	—	-17	-10	-3	mV	
Hall input sensitivity	V <sub>HIN</sub>	—	80	—	—	mV p-p	
Common-mode input voltage range	V <sub>ICM</sub>	One side input bias	0	—	V <sub>REG</sub>	V	

Notes : \*2 Typical design value

**Electrical Characteristics (continued)**

at V<sub>CC</sub>=24V,

Note: T<sub>a</sub> = 25°C±2°C unless otherwise noted.

Parameter	Symbol	Condition	Limits			Unit	Note
			Min	Typ	Max		
<b>Charge pump output</b>							
Output boosted voltage	V <sub>PUMP</sub>	I <sub>pump</sub> =0mA	V <sub>CC</sub> +5	V <sub>CC</sub> +7	V <sub>CC</sub> +9	V	
<b>VCC under voltage lock out</b>							
Operation voltage	V <sub>UVLO</sub>	—	4.5	4.8	5.1	V	
Hysteresis width	ΔV <sub>UVLO</sub>	—	0.1	0.2	0.3	V	
<b>Current limiter operation</b>							
Limiter voltage	V <sub>RF</sub>	INSEL=H	0.19	0.21	0.23	V	
<b>FG Block</b>							
Output on-resistance	V <sub>ONFG</sub>	I <sub>FG</sub> =5mA	-	40	60	Ω	
Output leak current	I <sub>LFG</sub>	V <sub>O</sub> =5V	-	-	10	μA	
<b>BR Interface</b>							
High level input voltage	V <sub>THBR</sub>	—	2.0	—	VREG	V	
Low level input voltage	V <sub>TLBR</sub>	—	0	—	1	V	
Input open voltage	V <sub>IOBR</sub>	—	2.65	3	3.35	V	
Hysteresis width	V <sub>ISBR</sub>	—	0.25	0.33	0.4	V	
High level input current	I <sub>IHBR</sub>	V <sub>BR</sub> =5V	45	60	75	μA	
Low level input current	I <sub>ILBR</sub>	V <sub>BR</sub> =0V	-60	-80	-100	μA	
<b>FR Interface</b>							
High level input voltage	V <sub>THFR</sub>	—	2.0	—	VREG	V	
Low level input voltage	V <sub>TLFR</sub>	—	0	—	1	V	
Input open voltage	V <sub>IOFR</sub>	—	2.65	3	3.35	V	
Hysteresis width	V <sub>ISFR</sub>	—	0.25	0.33	0.4	V	
High level input current	I <sub>IHFR</sub>	V <sub>FR</sub> =5V	45	60	75	μA	
Low level input current	I <sub>ILFR</sub>	V <sub>FR</sub> =0V	-60	-80	-100	μA	

**Electrical Characteristics (continued)**

at  $V_{CC}=24V$ ,

Note:  $T_a = 25^{\circ}C \pm 2^{\circ}C$  unless otherwise noted.

Parameter	Symbol	Condition	Limits			Unit	Note
			Min	Typ	Max		
<b>PWMIN Interface (Switching by PWMIN/VSP pin, at INSEL=H)</b>							
High level input voltage	$V_{THPWMI}$	—	2.0	—	VREG	V	
Low level input voltage	$V_{TLPWMI}$	—	0	—	1	V	
Input open voltage	$V_{IOPWMI}$	—	2.65	3	3.35	V	
Hysteresis width	$V_{ISPWMI}$	—	0.25	0.33	0.4	V	
High level input current	$I_{HPWMI}$	$V_{PWMIN}=5V$	45	60	75	$\mu A$	
Low level input current	$I_{LPWMI}$	$V_{PWMIN}=0V$	-67	-90	-113	$\mu A$	
Recommended input frequency	$F_{PWMIN}$	Design recommended value	0.5	—	60	kHz	
<b>INSEL Interface</b>							
High level input voltage	$V_{INSELH}$	—	$V_{CC} - 1$	—	$V_{CC}$	V	
Low level input voltage	$V_{INSELL}$	—	0	—	1	V	
<b>FGSEL Interface</b>							
High level input voltage	$V_{FGSELH}$	—	$V_{REG} - 1$	—	$V_{REG}$	V	
Low level input voltage	$V_{FGSELL}$	—	0	—	1	V	
<b>OFFSW Interface</b>							
High level input voltage	$V_{OFFSWH}$	—	$V_{REG} - 1$	—	$V_{REG}$	V	
Low level input voltage	$V_{OFFSWL}$	—	0	—	1	V	
<b>VSP Interface (Switching by PWMIN/VSP pin, at INSEL=L)</b>							
Input dynamic range L level	$V_{SPDL}$	—	0.8	1	1.2	V	
Input dynamic range H level	$V_{SPDH}$	—	2.25	2.5	2.75	V	
Input to output gain	$V_{SPG}$	$V_{SP}=1.3 \sim 2.2V$	0.126	0.14	0.154	V/V	
Threshold voltage of free-run comparator	$V_{FRC}$		0.8	0.9	1.0	V	
OFF time1	$V_{OFFT1}$	OFFSW=H	1.1	2.2	3.5	$\mu s$	
OFF time2	$V_{OFFT2}$	OFFSW=L	4.2	7.0	11	$\mu s$	
<b>Thermal protection</b>							
Thermal shutdown operation temperature	TSD	Design target value	-	160	-	$^{\circ}C$	*1
Hysteresis width	$\Delta TSD$	Design target value	-	40	-	$^{\circ}C$	*1

Notes : \*1 These are values checked by design but not production tested.



■ Pin Configuration

TOP VIEW

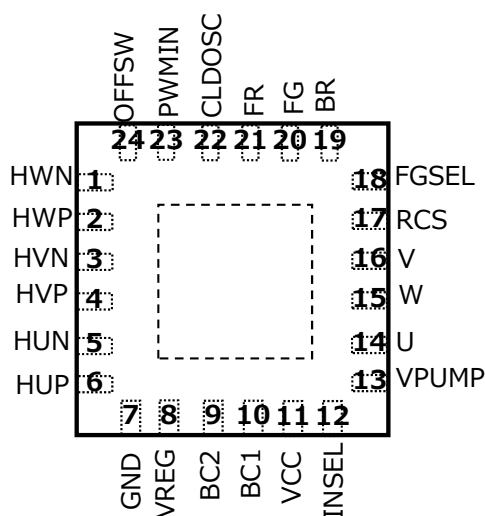

**Pin Functions**

Pin No.	Pin name	Type	Description
1	HWN	Input	Hall amplifier input W (-), Connected to the output pin of the Hall element.
2	HWP	Input	Hall amplifier input W (+), Connected to the output pin of the Hall element.
3	HVN	Input	Hall amplifier input V (-), Connected to the output pin of the Hall element.
4	HVP	Input	Hall amplifier input V (+), Connected to the output pin of the Hall element.
5	HUN	Input	Hall amplifier input U (-), Connected to the output pin of the Hall element.
6	HUP	Input	Hall amplifier input U (+), Connected to the output pin of the Hall element.
7	GND	GND	Ground
8	VREG	Output	Internal reference voltage (5V)
9	BC2	Output	For charge pump 2, Capacitor is connected between BC1 and BC2
10	BC1	Output	For charge pump 1, Capacitor is connected between BC1 and BC2
11	VCC	Power Supply	Supply voltage for IC and motor.
12	INSEL	Input	PWMIN or VSP mode selection pin
13	VPUMP	Output	Charge pump voltage output
14	U	Output	U-phase output
15	W	Output	W-phase output
16	V	Output	V-phase output
17	RCS	Output	Motor current limit (PWMIN mode) / Motor current detector (VSP mode)
18	FGSEL	Input	FG output mode selection
19	BR	Input	Brake mode selection
20	FG	Output	FG external output
21	FR	Input	Forward / Reverse rotation direction selection
22	CLDOSC	Input	Setting oscillation frequency of motor restricted protection
23	PWMIN/VSP	Input	PWM input (PWMIN mode) or DC voltage input (VSP mode) for motor control
24	OFFSW	Input	PWM OFF time selection

■Block diagram

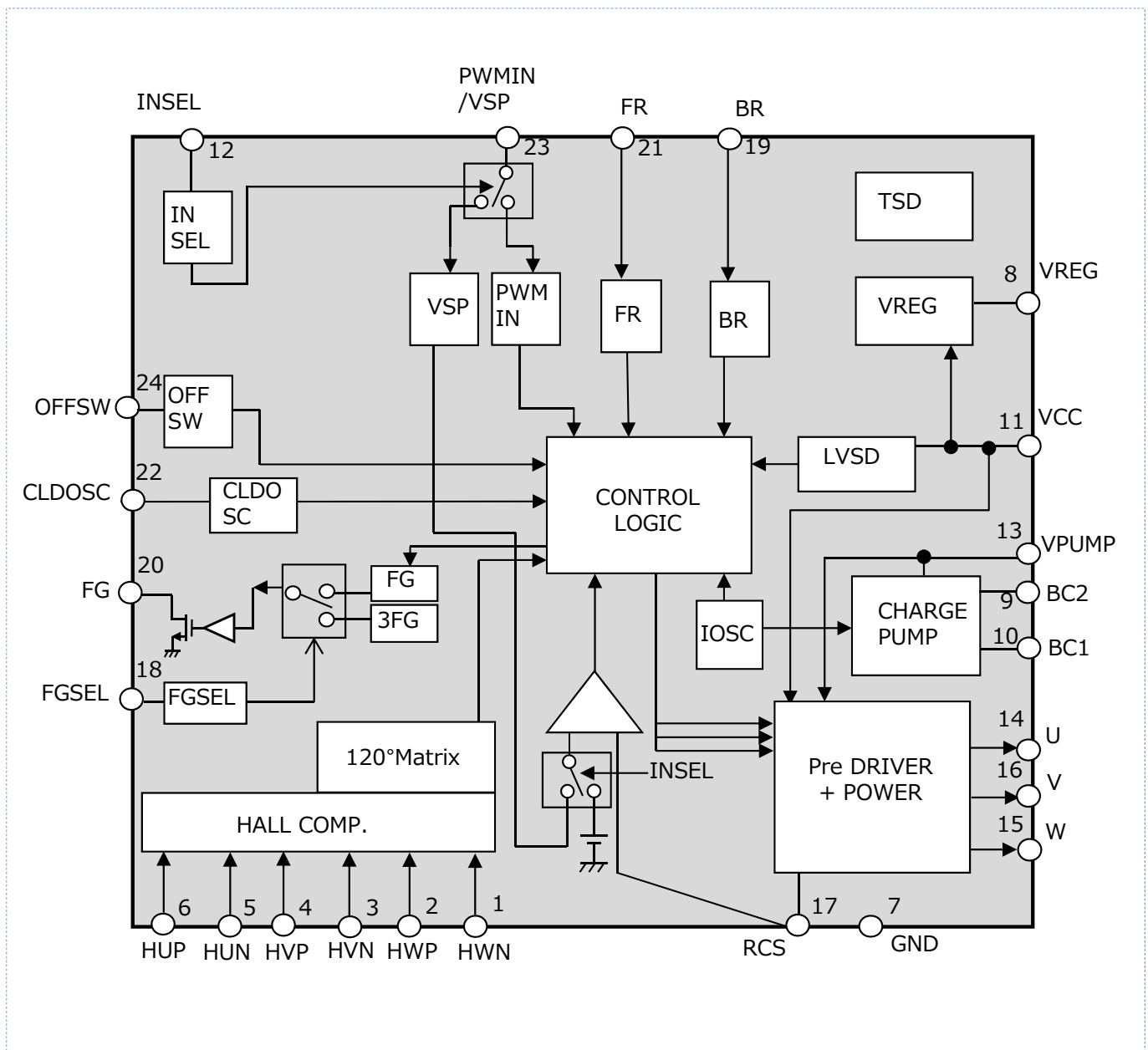

Note: This block diagram is for explaining functions. The part of the block diagram may be omitted, or it may be simplified.

■Application Circuit Diagram

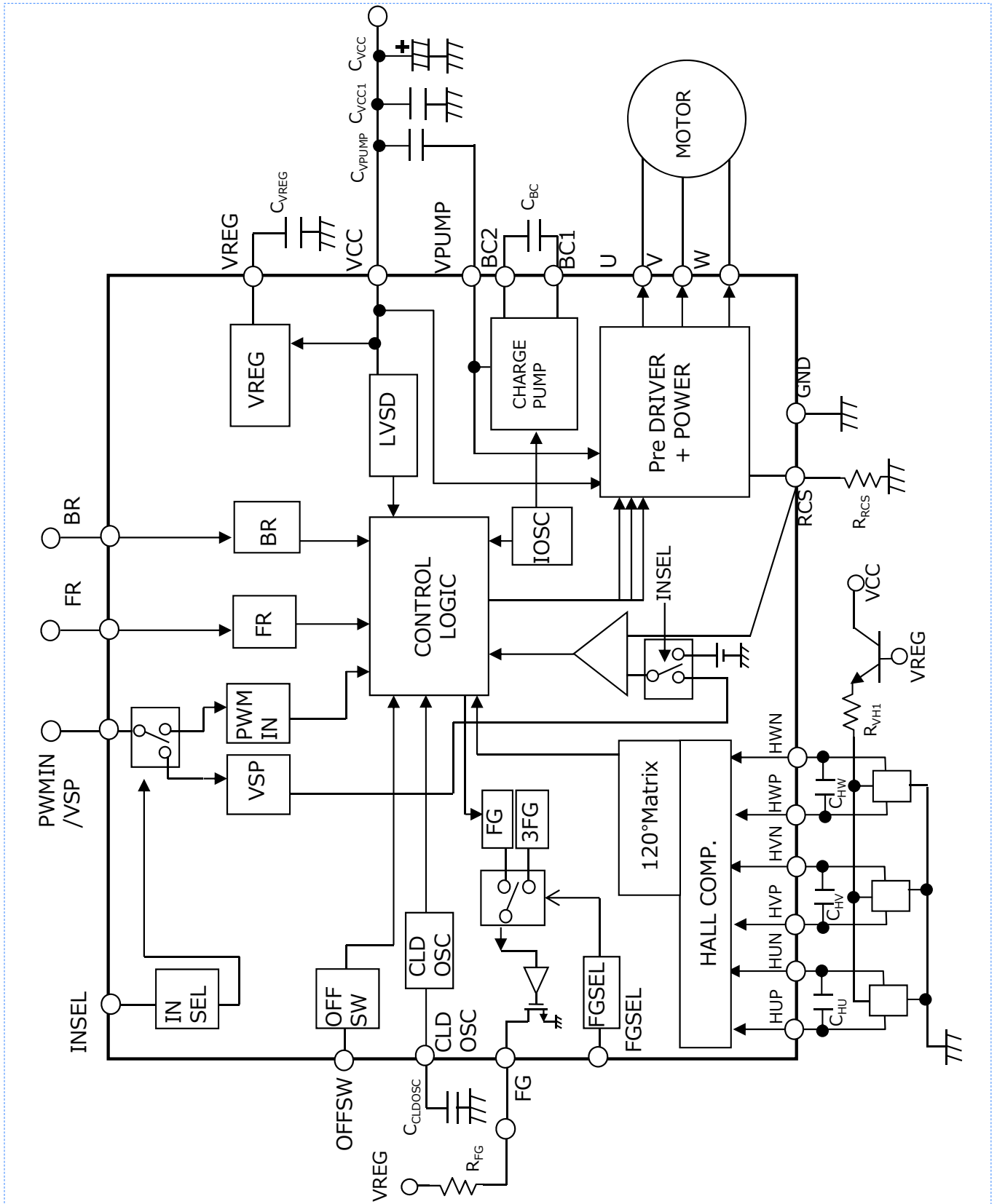

Note: · This simplified application circuit is not guaranteed the operation of mass production set.  
 Use this IC after sufficient evaluation and examination on customer responsibility when designing the set.  
 · For the feature explanation, this block diagram may be partially omitted or simplified.

■ **Functional Pin Table**

1. Selection of PWMIN mode or VSP mode (selectable by INSEL pin)			
Pin name	Input	Status	Description
INSEL	H(VCC)	PWMIN mode	External PWM signal is input and the PWM through drive mode which carries out open control of the output is chosen.
	L(GND)	VSP mode	External DC voltage is input and the OFF time fixed PWM drive mode which carries out loop control of the output by current peak detection is chosen.
2. Selection of FG output			
FGSEL	H(VREG)	3FG	3FG pulse output
	L(GND)	1FG	1FG pulse output
3. Selection of Fixed OFF time			
OFFSW	H(VREG)	OFF time 1	2.2u sec
	L(GND)	OFF time 2	7.0u sec
4. Function of Brake			
BR	H or Open	SBRK	Low side : Short brake
	L	Normal	Normal drive.
5. Function of Forward/Reverse			
F/R	H or Open	Forward	Rotation U→V→W
	L	Reverse	Rotation W→V→U
6. PWMIN/VSP pin input.			
Selection mode	Pin condition	Drive mode	Description
PWMIN mode (INSEL=H) →PWM signal input	PWM signal input	Normal Drive	An output power transistor is made to drive by the frequency and duty of an input PWM signal. PWMIN=L → Low side power : ON PWMIN=H → Low side power : OFF
	0% duty input	Free Run	If H level mode of an input PWM signal is continued in about 5 msec, it judges with duty 0% and will be in a free-run mode.
VSP mode (INSEL=L) →DC voltage input	VSP voltage of 1V to 2.5V is input.	Normal Drive	The input range of VSP voltage is 1V to 2.5V. It is made to drive by the current peak detection according to VSP voltage and the resistance of the RCS pin.
	VSP<0.9V	Free Run	It will be in a free-run mode by VSP<0.9V.
	VSP>2.5V	MAX Drive	It drives in the mode of VSP=2.5V.

■ Protection Function

Function name	Operate	Release	Note
TSD	160°C	120°C	All phases are OFF while protection function works. (output = HiZ) Moreover, when the TSD protection operates, the timer count of a restricted protection is made to stop.
Current limit (at PWMIN mode)	0.21V	After fixed time progress	In PWM through drive mode, if motor current reaches the current value decided by the resistance connected to the RCS pin and the internal reference voltage of 0.21V, output current will be restricted in turning off an output for a fixed time. OFF time can be decided by setting of an OFFSW pin. (OFFSW=H : 2.2usec, OFFSW=L : 7.0usec)
UVLO (VCC)	4.8V	5.0V	It is protection of the low-voltage condition of the power supply voltage. If protected operation is carried out, low side output power is turned on and it becomes a low side short brake.
Motor restricted protection	When FG pulse does not change within a set time. (latch protection)	•F/R operation •at UVLO •to STBY mode •BR operation •at TSD (count stop)	The count for restricted protection is made to stop at the time of TSD protected operation. Protection release and a count are reset except above. A protection setting time is determined by the external capacity value connected to the CLDOS pin. (Time(s) = External Cap(uF) × 85)
Short protection of Motor output - GND,VCC	latch protection by constant time detection.	•at UVLO •to STBY mode	Latch protection is carried out. Release is performed by UVLO and STB.



**3 Phase Drive State Diagram**

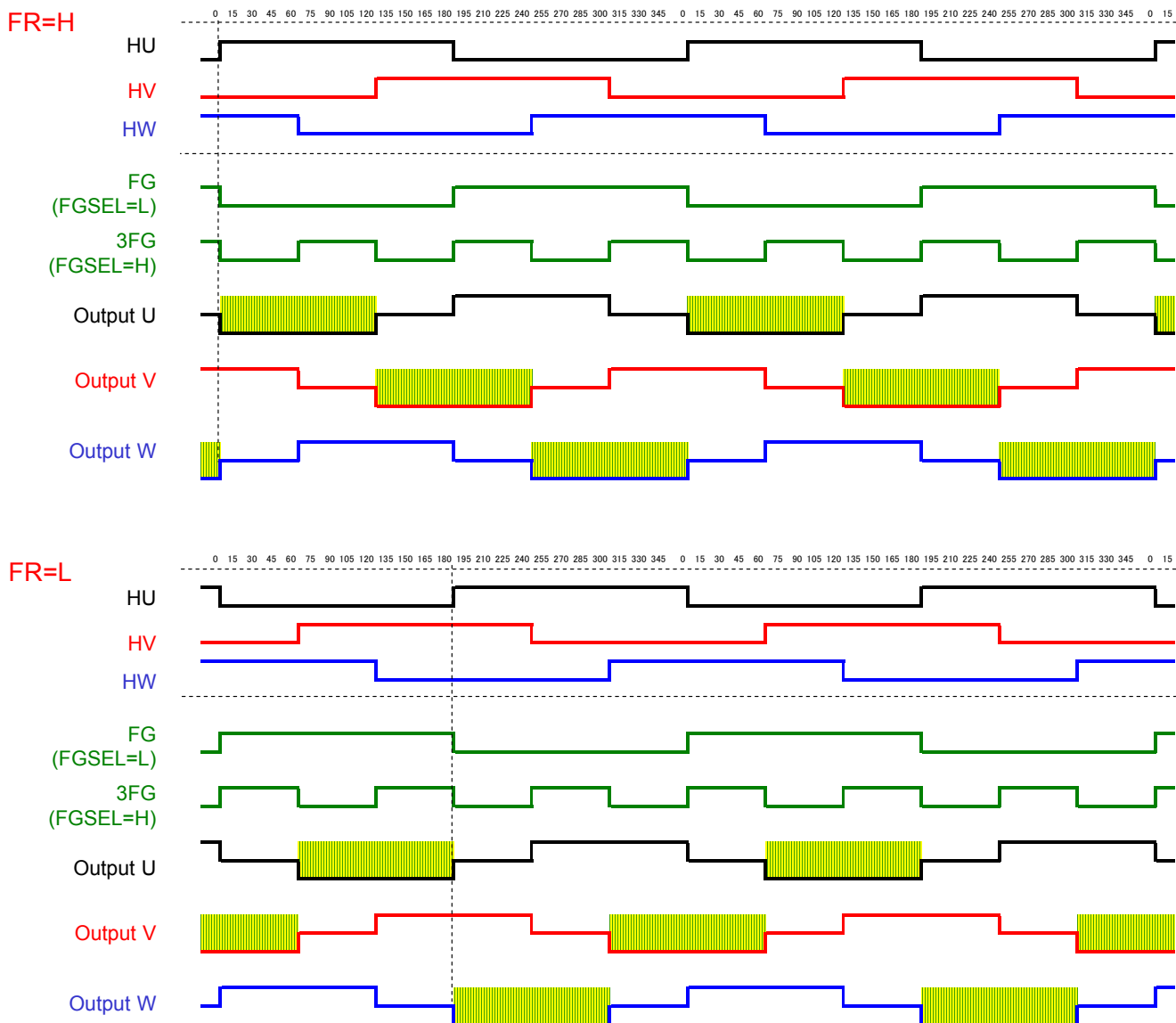

FR=H			FR=L			OUTPUT		
HU	HV	HW	HU	HV	HW	U	V	W
H	L	H	L	H	L	PWM	H	Z
H	L	L	L	H	H	PWM	Z	H
H	H	L	L	L	H	Z	PWM	H
L	H	L	H	L	H	H	PWM	Z
L	H	H	H	L	L	H	Z	PWM
L	L	H	H	H	L	Z	H	PWM

■ As for FG output, the inversion signal of HU is output.

HU, HV, and HW = H show the following state, respectively.  
 HUP > HUN,  
 HVP > HVN,  
 HWP > HWN.

About the output U, V, and W,  
 As for H, output high side power is ON,  
 As for PWM, output power is a switching mode,  
 As for Z, output power is OFF, It is shown.

## Functional Explanation

### 1. Selection of PWMIN mode or VSP mode

As a motor drive mode, it features two modes in this IC.  
 The mode selection is selectable by INSEL pin.

INSEL=H → PWMIN mode  
 INSEL=L → VSP mode

**PWMIN mode**··· This mode is the mode which inputs a PWM signal into a PWMIN/VSP pin and makes an output drive with the signal.  
 It is the open control drive of a PWM through system.

**VSP mode**····· DC voltage is input into a PWMIN/VSP pin and it operates in the fixed OFF time current peak detection PWM drive mode which makes it drive with carrying out current detection in a RCS pin.  
 It is the loop control by current peak detection.

Moreover, opening of the INSEL pin is prohibited.  
 Be sure to apply voltage to the pin so that the polarity can be decided.

Drive mode	PWM system	PWM generation	Summary block diagram
PWM IN mode	PWM through	PWMIN = PWM OUT	
VSP mode	Fixed OFF time	ON Timing : Fixed OFF time progress  OFF Timing : Setting current value detection	

**Functional explanation (continued)**

**2. Start Up/Free Run/Standby(STB) mode**

·In this IC, the transition conditions to Start Up, Free Run and STB mode are shown.

**·PWMIN mode**

Start Up····· After applying the VCC of power supply within the operation limits, if a PWM signal is input from a PWMIN/VSP pin, a PWM input is judged and internal VREG voltage circuit starts. If it becomes the VREG voltage on which the internal circuit can operate, it becomes a normal drive in the PWMIN mode.

Free Run··· If the 0% duty mode (H level) of a PWM signal continues in about 5 msec, it judges as a PWM 0% inside IC, and becomes Free Run mode. At the time of Free Run, low side power outputs are all OFF, and high side power output of the detection phase of a hole is in ON state.

STB······· After a Free Run, rotation of a motor is stopped, FG pulse is no longer output, time that is decided by capacity value connected to the CLDOSC pin elapses, it transits to STB mode. Internal VREG voltage is stopped in the STB mode.

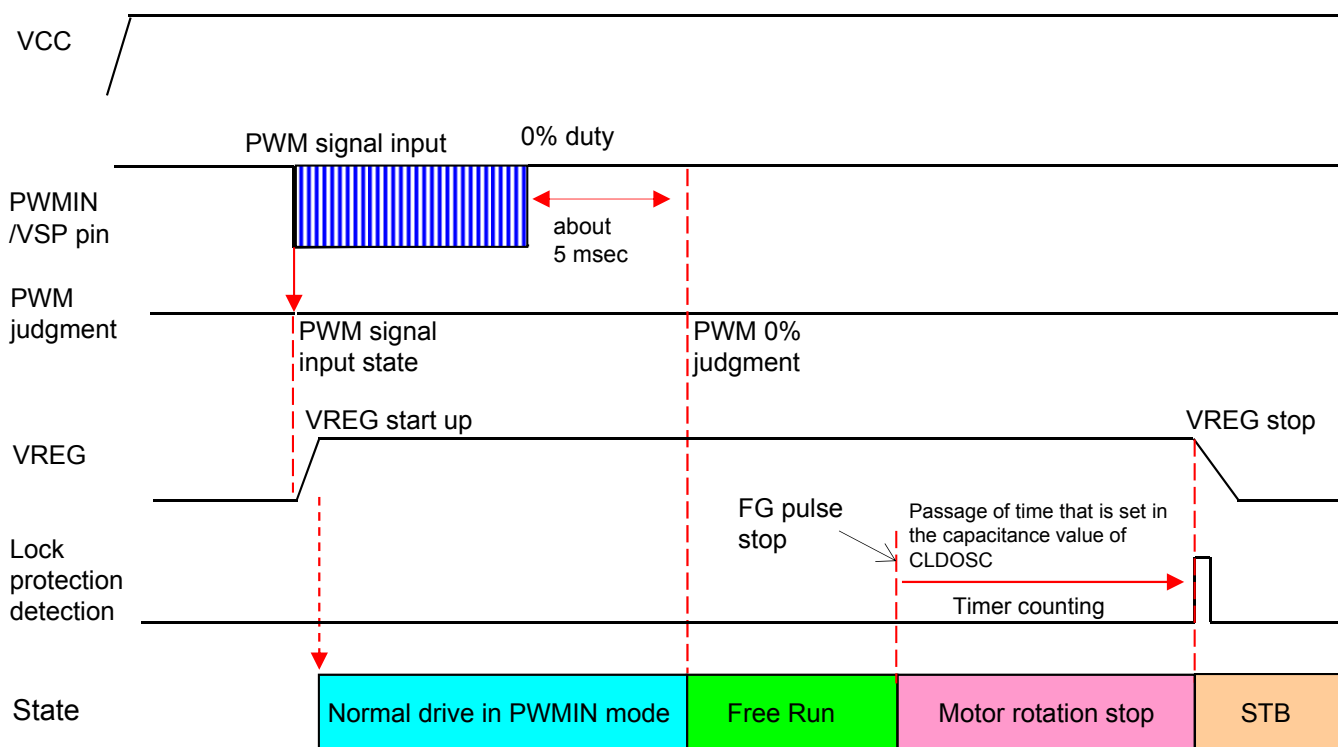

**Functional Explanation (continued)**

**·VSP mode**

**Start Up**·····After applying the VCC of power supply within the operation limits, if the voltage of 0.9V or more from PWMIN/VSP pin is input, it is judged as normal drive, and internal voltage circuit starts. If it becomes the VREG voltage on which the internal circuit can operate, it becomes a normal drive in the VSP mode. (However, VSP voltage input range of VSP mode is 1V to 2.5V.)

**Free Run**·····If PWMIN/VSP pin voltage becomes 0.9V or less, it is judged as free-run in the IC, and it becomes Free Run mode. At the time of Free Run, low side power outputs are all OFF, and high side power output of the detection phase of a hole is in ON state.

**STB**······· After a Free Run, the rotation of the motor is stopped . From the time the FG pulse is not detected, after the time elapses that is determined by the capacitance value connected to the terminal CLDOSC, it transits to the STB mode. And it stops the internal VREG voltage in the STB mode.

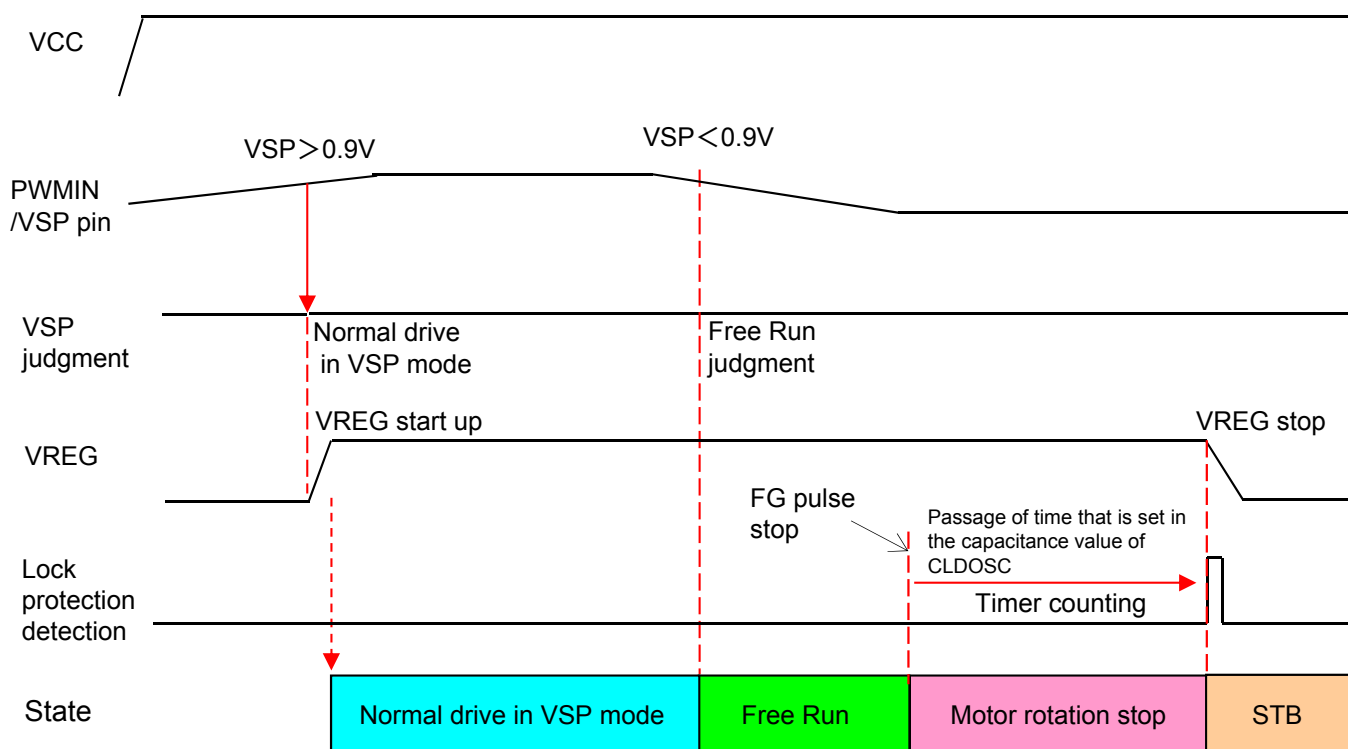

### Functional Explanation (continued)

#### 3. Speed control

##### • PWMIN mode (INSEL=H)

By inputting a PWM signal to PWMIN/VSP pin and controlling its duty, it controls the output.

PWMIN/VSP pin:

L level voltage input → PWM phase (Low side) output ON

H level voltage input → PWM phase (Low side) output OFF

In the PWMIN mode, if the input PWM signal voltage continues in about 5 msec, it judges as 0% duty, and transits to Free Run mode.

##### • VSP mode (INSEL=L)

By inputting the DC voltage to PWMIN/VSP pin and controlling the voltage, it controls the motor current.

VSP mode is OFF time constant current peak detection system. By setting a target current value, make the loop control to match its value.

$$\text{Target current value(A)} = \frac{(\text{VSP input voltage} - 1) \times 0.14 \text{ (V)}}{\text{RCS external resistance value } (\Omega)}$$

Input voltage range of VSP in normal drive of VSP mode is 1V to 2.5V.

When VSP voltage is 0.9V or less, it becomes Free Run mode.

If you input more than 2.5V voltage to VSP, it is set to 2.5V in the IC.



**Functional Explanation (continued)**

**4. Motor restricted protection circuit**

When FG non-signal state continues for a certain period of time in the motor normal operation mode, restricted protection circuit operates.

In the restricted protection mode, low side power outputs are in 3-phase OFF state.

The value of the restricted protection time can be calculated by the following equation approximately.

$$\text{Restricted protection setting time (s)} \approx \text{Capacitance value of CLDOSC (}\mu\text{F)} \times 85$$

If you connect capacitance of 0.047 $\mu$ F in CLDOSC pin, the restricted protection time is about 4s. Make setting with a margin for motor start-up time.

Conditions to release the motor restricted protection, and to reset the counter are as follows.

- BR pin: Short brake setting
- In switching the FR pin
- In detecting UVLO mode
- In transiting to STB mode
- at TSD protection (count stop)

This setting time is used as the time from free-run, stopping motor, until entering STBY mode.

If you do not use the restricted protection, connect the CLDOSC pin to the GND. (However, It will not be able to transit to the STBY mode.)

**1. Restricted protection explanation**

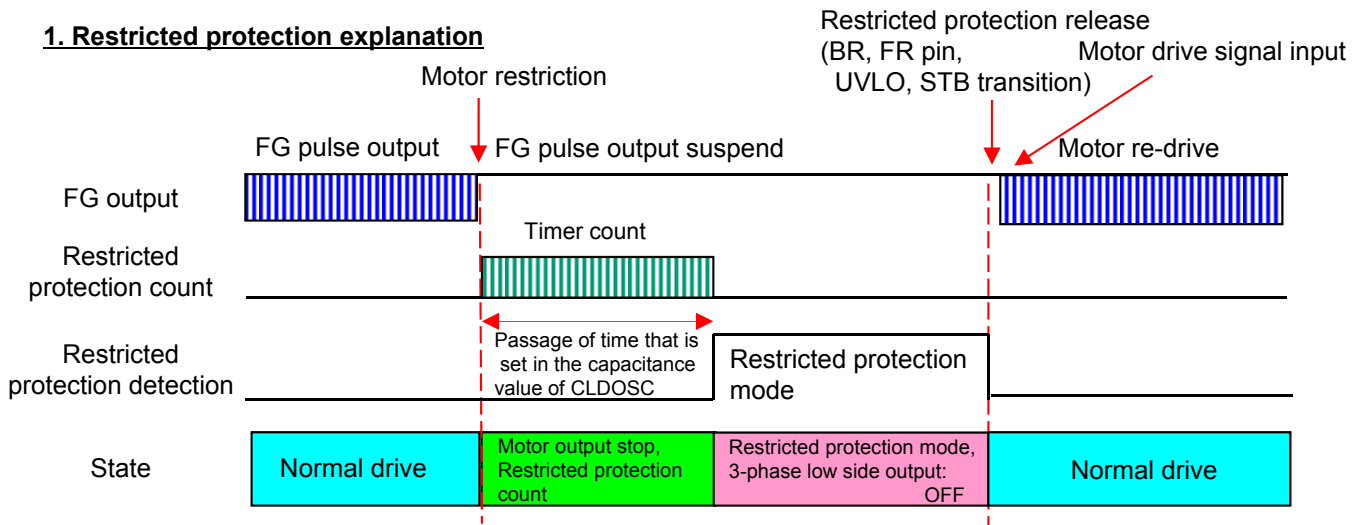

**2. Restricted protection explanation in operating TSD protection**

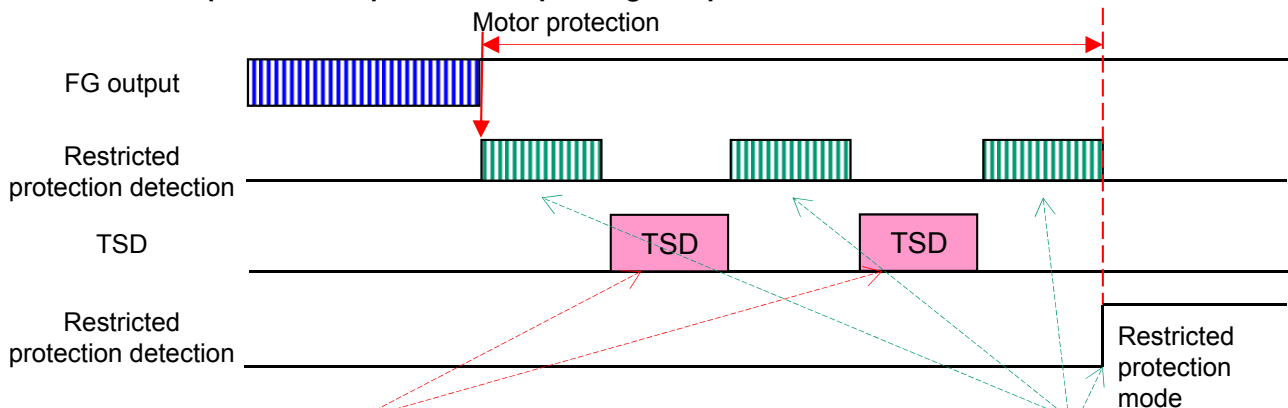

If the TSD protection is activated during the restricted protection count, it stops the restricted protection count during the protection.

If the sum of restricted count reaches to the setting time, it transits to the Restricted protection mode.

**Functional Explanation (continued)**

**5. Low voltage protection**

This IC monitors the voltage VCC. If VCC voltage becomes 4.8V or less, low-voltage protection is activated. In the low voltage protection operation, the output of each phase is in Short-circuit braking mode (low side short).

In addition, if the VCC voltage drops further, the internal circuit is no longer working properly, the outputs, all phases are HiZ (all phases OFF).

Hysteresis of 0.2V is set in the VCC low voltage protection function. If the VCC is restored to 5V from protection mode, the low voltage protection is released.

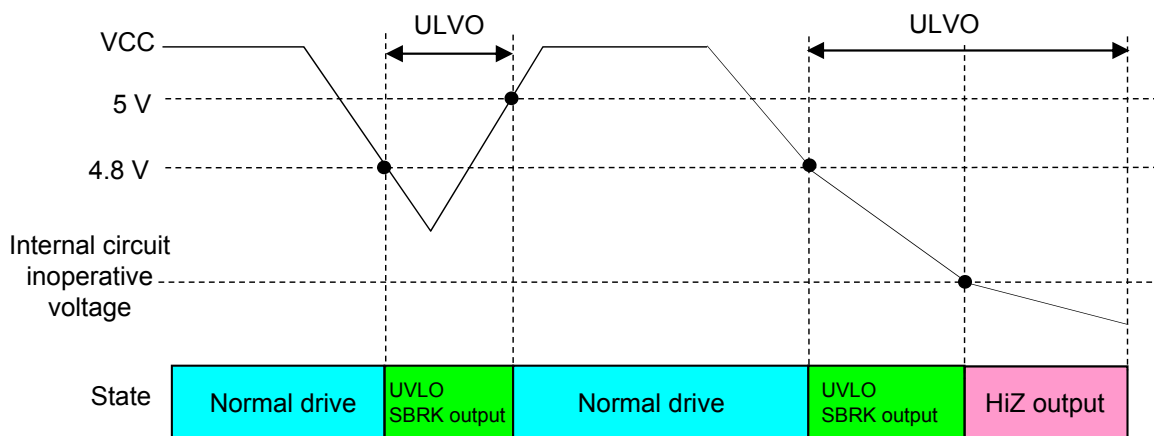

**6. Thermal protection (TSD)**

If an IC junction temperature is 160°C (design target value) or more, the thermal protection is activated, and the motor outputs are all HiZ (all phases OFF).

If the IC junction temperature is 120°C (design target value) or less, the protection is released. During the period of TSD protection, the count of the restricted protection circuit is stopped.

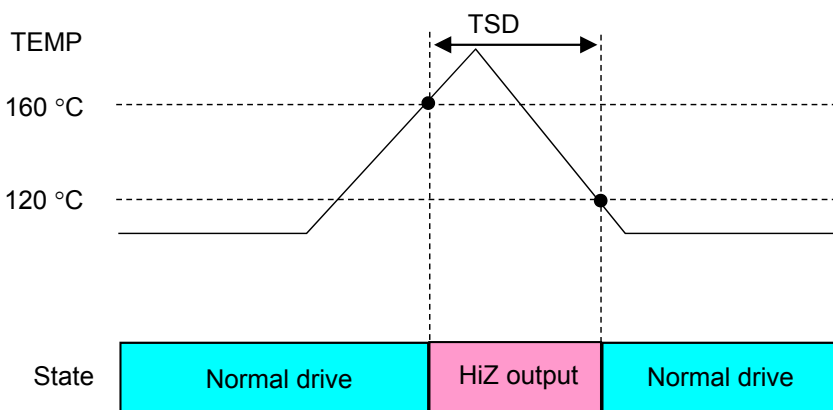

## Functional Explanation (continued)

### 7. Overcurrent protection (PWMIN mode)

Here, describes the overcurrent protection setting in PWMIN mode.  
Overcurrent setting value is determined by the resistance value connected to the RCS pin.

$$\text{Overcurrent setting value (A)} = 0.21 \text{ (V)} / \text{RCS resistance value } (\Omega)$$

After detecting a current greater than the setting value, by shutting off the output transistor during the predetermined time, it protects an over-current.

Off time is possible to switch using OFFSW pin.

- OFFSW=H: Off time 2.2 usec
- OFFSW=L: Off time 7.0 usec

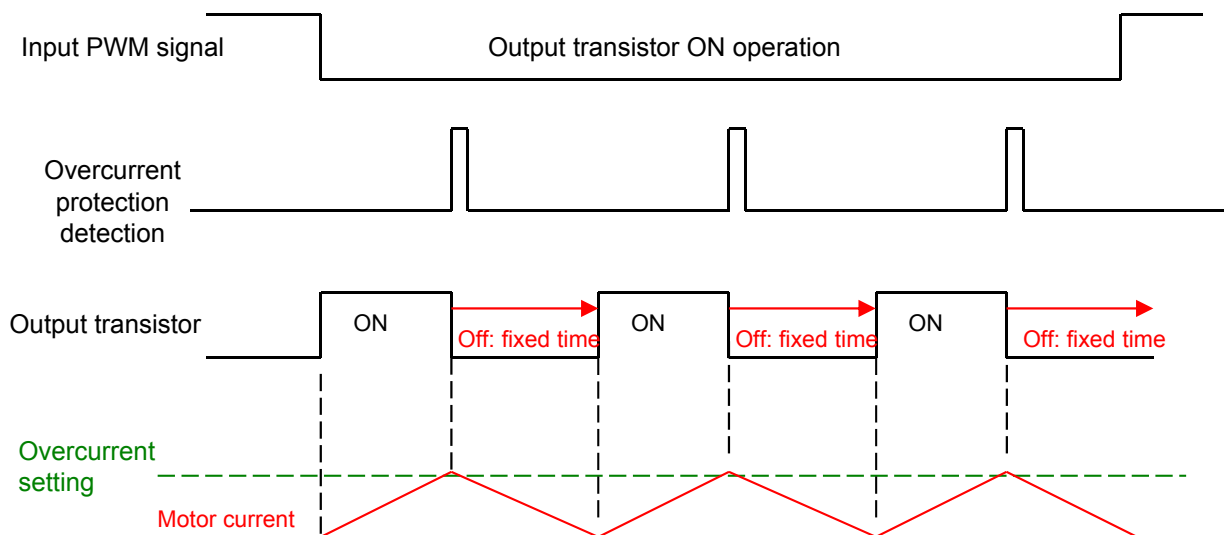

**Functional Explanation (continued)**

**8. Hall input**

Hall hysteresis comparator carries out position detection. If the amplitude of the sine wave is small, the phase delay of the comparator output becomes significant, therefore, increase the amplitude. Recommendation is 200 mV or more. Also, if the hole chattering occurs, put capacitor between HP (2, 4, 6 pin) and HN (1, 3, 5 pin).

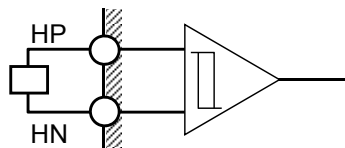

The following is a schematic diagram of the characteristics.

J-1 hysteresis level: 10 mV L → H

J-2 hysteresis level: 10 mV H → L

J-3 hysteresis width: 20.0 mV (typ)

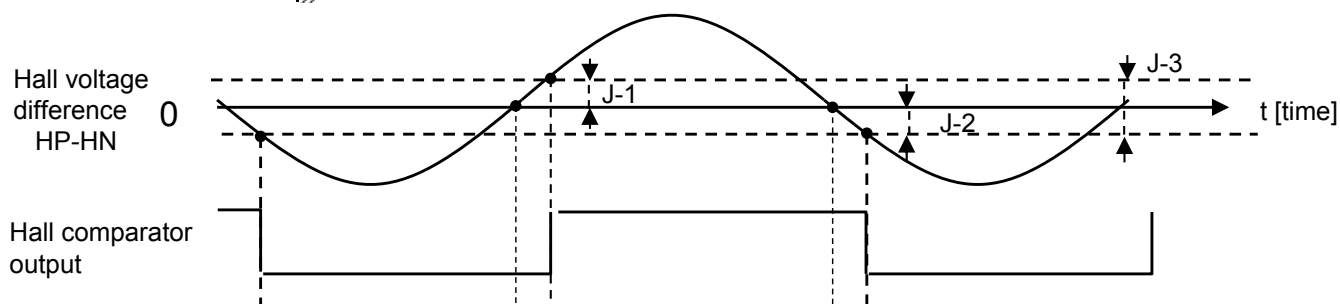

**Relationship between Hall voltage and FGSEL**

By switching FGSEL pin, for the one cycle sine wave of Hall, it outputs FG pulse one cycle or three cycles.

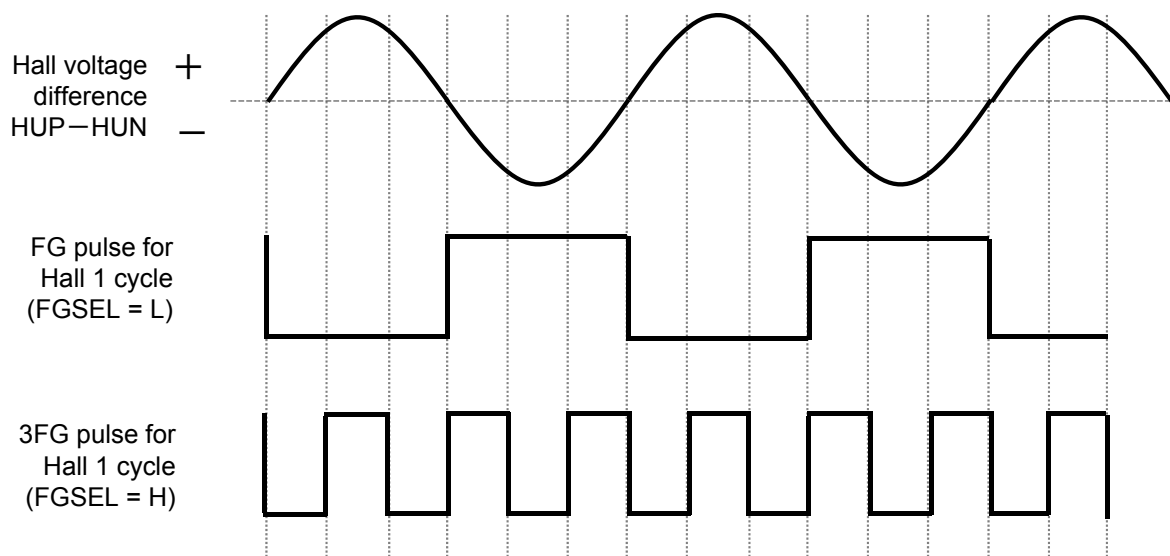

### Functional Explanation (continued)

#### 9. FGSEL pin

For Hall 1 cycle, you can choose whether the output of the FG pin is 1FG or 3FG.  
See the previous page for more information.

Open of the FGSEL pin is prohibited.  
On the board, give it to VREG voltage or GND voltage.

#### 10. OFFSW pin

In the VSP mode, you can set the OFF time of OFF time constant current peak detection PWM drive control.  
At OFFSW = H, OFF time is 2.2 usec.  
At OFFSW = L, OFF time is 7.0 usec.

In the PWMIN mode, you can set the protection time of the overcurrent protection operation.  
At OFFSW = H, protection time is 2.2 usec.  
At OFFSW = L, protection time is 7.0 usec.

Refer to page 20 for more information.

Open of the OFFSW pin is prohibited.  
On the board, give it to VREG voltage or GND voltage.

#### 11. BR pin

By the voltage setting of BR pin, you can choose whether the output is normal drive or low side SBRK of low side power output three-phase ON.

At BR=L: Output is normal drive.  
At BR=H: Output is low side SBRK.

When open the BR pin, it generates about 3V in the internal circuit, and it is determined that BR = H internally, then it transits to SBRK mode.

Drive the BR pin with an external voltage.  
If the VREG voltage of IC is used, at the time becoming STBY mode, VREG voltage is not lowered and voltage of 1 to 2V is output. So the use of voltage VREG is prohibited.

At short braking, brake current is determined by the motor and speed.  
Consider enough to prevent the IC destruction.



### Functional Explanation (continued)

#### 12. FR pin

By the voltage setting of the FR pin, you can choose whether forward rotation or reverse rotation.

FR=H: Output is forward rotation.

FR=L: Output is reverse rotation.

Refer to page 13 for more information.

When you open the FR pin, it generates about 3V in the internal circuit, it is determined that the FR = H internally, and it becomes the forward rotation mode.

Drive FR pin by an external voltage.

If you use the VREG voltage of IC, when it becomes STBY mode, VREG voltage does not fall and VREG voltage about 1 to 2V is output, so the use of voltage VREG is prohibited.

In addition, F/R control is instantly reversed.

At the time of instantaneous reversal when the motor is driven, there is a possibility of high current generated by the rotational speed or the current value.

By dropping the number of revolutions before reversal, etc., you must fully assess so that the IC is not broken.

#### 13. PWMIN/VSP pin

● In the PWMIN mode, it becomes the pin of the PWM signal input.

PWMIN=L: PWM drive output is ON. (ON duty)

PWMIN=H: PWM drive output is OFF. (OFF duty)

In addition, this pin also shares with the activation determination. In the STBY mode, L-level voltage is input to the PWMIN pin, it releases the STBY mode, and VREG voltage starts.

Also, this pin shares with free-run determination. Under normal operating conditions, if the time that PWMIN is H level continues in 5 msec, it determines 0% duty internally and the output becomes the Free run mode.

At the time of 0% duty in 5msec before free-run, the outputs in the upper phase 2 are ON, and they are in the upper SBRK mode. By a motor and rotational speed, there is a possibility of high current generation.

If you want to transit from high duty to free-run, you should fully assess so that the IC is not broken, .

When you open the PWMIN/VSP pin in the PWMIN mode, it generates about 3V in the internal circuit, and it is determined that the H-level voltage input internally, and the outputs become OFF, and it stop the motor drive.

● In the VSP mode, it becomes the pin of DC voltage input.

By the input of the 1V to 2.5V and loop control of the current peak detection according to the input voltage, it drives the output.

This pin also shares with the activation determination, if DC voltage of 0.9V or more is input, it releases the STBY mode, and VREG voltage starts.

Also, this pin shares with free-run determination. By the input voltage of 0.9V or less, it comes up with free-run decision.

When you open the PWMIN/VSP pin in the VSP mode, it is determined that the voltage is 0.9V or less internally, the operation stops the motor drive.

Refer to page 14-17 for more information.

**PIN EQUIVALENT CIRCUIT**

Note: The characteristics listed below are reference values derived from the design of the IC and are not guaranteed.

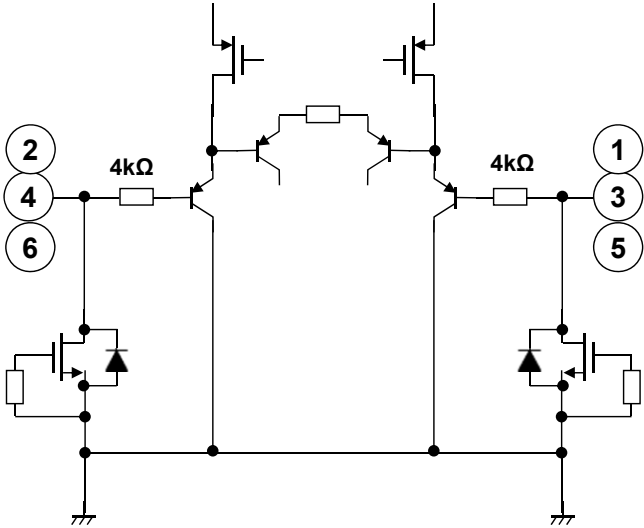
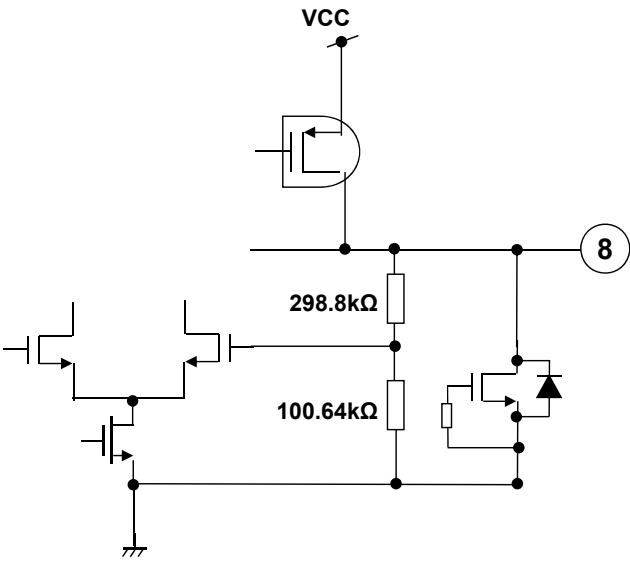
Pin No.	Internal circuit	Impedance	Description
1, 2, 3, 4, 5, 6		—	Pin1(HWN) ,Pin3(HVN),Pin5(HUN) :Hall amplifier (U, V, W) – input pin  Pin2(HWP) ,Pin4(HVP),Pin6(HUP) :Hall amplifier (U, V, W) + input pin
8		—	Pin8(VREG) :Internal reference voltage (5V)

**PIN EQUIVALENT CIRCUIT (continued)**

Note: The characteristics listed below are reference values derived from the design of the IC and are not guaranteed.

Pin No.	Internal circuit	Impedance	Description
9, 13		—	<p>Pin9 (BC2)                      :For charge pump capacitor connection pin 2                      Connect a capacitor between this pin and Pin10 (BC1).</p> <p>Pin13 (VPUMP)                      :Charge pump voltage output pin                      Connect a capacitor between this pin and Pin11 (VCC).</p>
10		—	<p>Pin10 (BC1)                      :For charge pump capacitor connection pin 1</p>