



Chipsmall Limited consists of a professional team with an average of over 10 year of expertise in the distribution of electronic components. Based in Hongkong, we have already established firm and mutual-benefit business relationships with customers from,Europe,America and south Asia,supplying obsolete and hard-to-find components to meet their specific needs.

With the principle of "Quality Parts,Customers Priority,Honest Operation,and Considerate Service",our business mainly focus on the distribution of electronic components. Line cards we deal with include Microchip,ALPS,ROHM,Xilinx,Pulse,ON,Everlight and Freescale. Main products comprise IC,Modules,Potentiometer,IC Socket,Relay,Connector.Our parts cover such applications as commercial,industrial, and automotives areas.

We are looking forward to setting up business relationship with you and hope to provide you with the best service and solution. Let us make a better world for our industry!



## Contact us

Tel: +86-755-8981 8866 Fax: +86-755-8427 6832

Email & Skype: info@chipsmall.com Web: www.chipsmall.com

Address: A1208, Overseas Decoration Building, #122 Zhenhua RD., Futian, Shenzhen, China





# Panasonic

ideas for life

NEW

## Machine Vision System

### IMAGECHECKER PV200

**High End Performance  
in a Compact Body**



# Compact & High Performance

ULTRA HIGH SPEED VISION SYSTEM IMAGECHECKER PV200





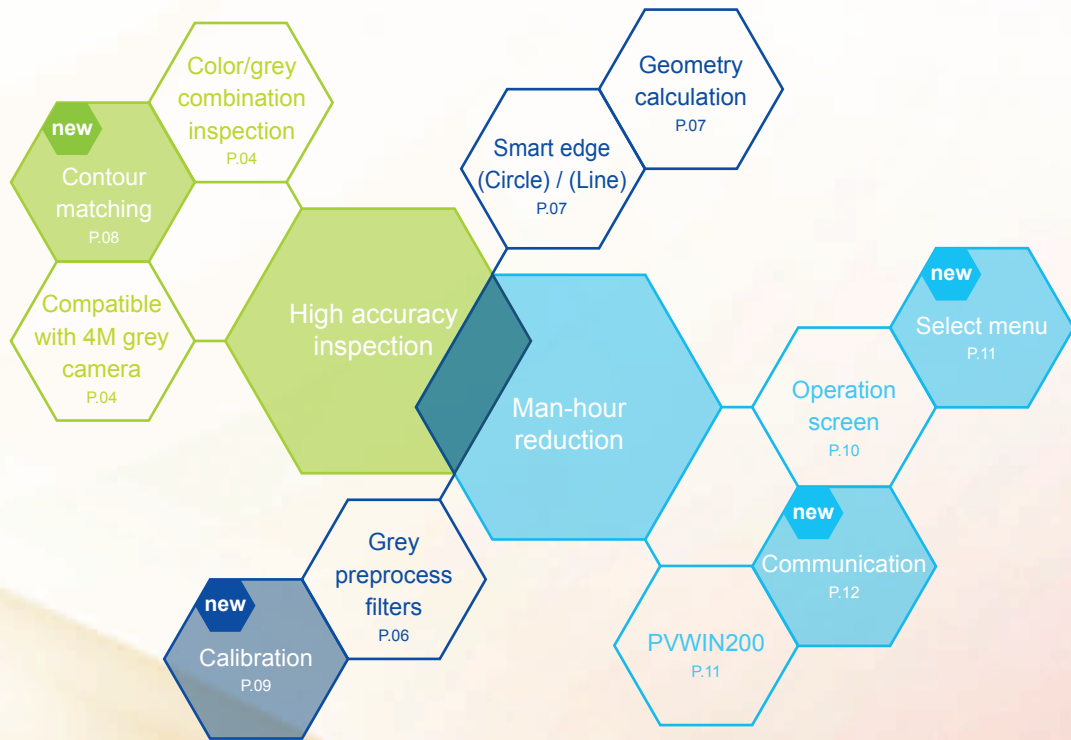

## Improved inspection reliability while reducing engineering time

Image processing with impressive accuracy and performance can now be achieved while requiring a surprisingly low implementation and programming time.

The new ideal machine is a color/grey combination type.

# Hardware

Color and grey images can be simultaneously captured for inspection.

In addition, the "3+1" Quad processor provides ultra-high speed parallel processing, significantly reducing the inspection time.

Features are condensed into the ultra-compact body guaranteeing outstanding usability.

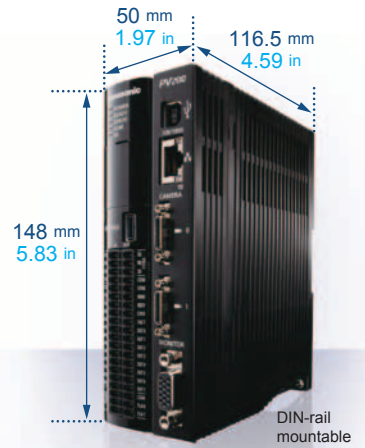

## Quad processor, DSP processing & Pipeline processing

"3 + 1" Quad processor for high speed processing

Consists of a processor exclusively for image capture and transfer, a high-speed RISC-CPU, image-processing DSP, and a processor exclusively for display processing

- Pipeline processing by the Quad processor enables concurrent operation of the image capture process and inspection process.
- Ease of operation is increased, because data R (read) / W (write) (see page 10) and display layout switching operations are possible in the RUN mode.
- DSP processing: High-speed DSP is a processor dedicated for realtime image and grey pre-process filtering.
- High reliability, fan-less, standalone hardware

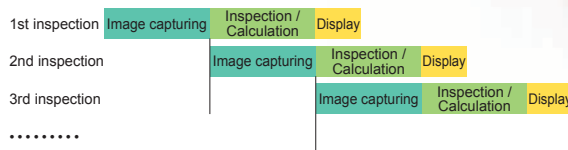
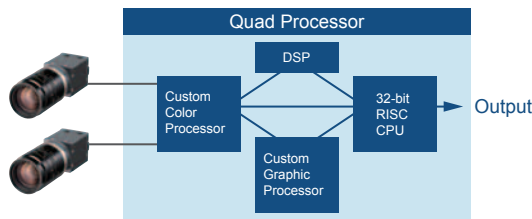

With pipeline (parallel) processing, image capturing and inspection can execute at the same time.

## Two cameras, including a combination of color and grey cameras, can be simultaneously connected.

High definition color and grey cameras can be simultaneously connected. Inspections with color and grey images can be conducted concurrently.

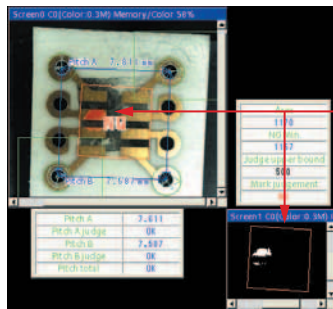

Color images clearly show red bad marks, which are difficult to detect with grey images.

## Camera selections



Six types of cameras, including a 4M grey camera, are available with the system.

0.3M compact grey camera has been added to the product line-up. The body is approximately 20 mm 0.79 in more compact lengthwise compared to previous 0.3M grey cameras.

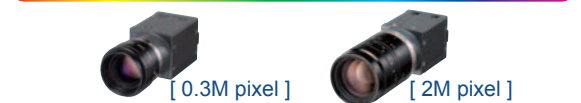

\*A dedicated cable is required for connecting.

\*The 4M camera cannot be used in combination with another type of camera.

## Color / Grey combination inspection system

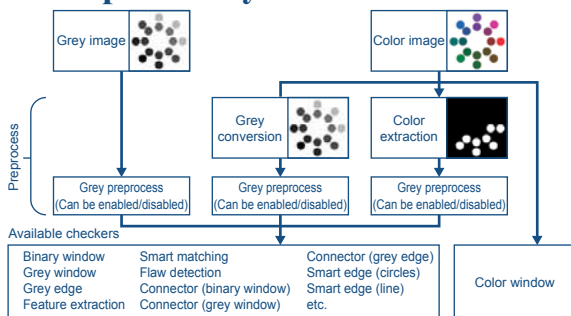

### Grey conversion

Highly flexible grey conversion is possible, because each coefficient can be freely specified for each RGB value of a color image.

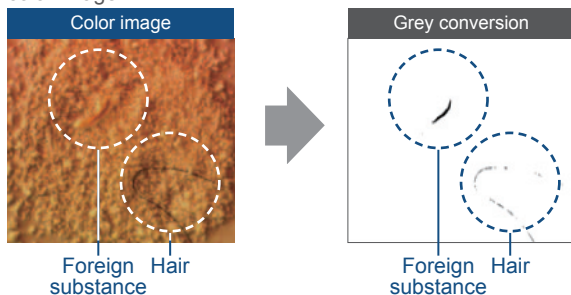

### Color window

The maximum, minimum, average, and deviation of RGB values can be obtained. Results can be used for numerical calculations and outputted externally.

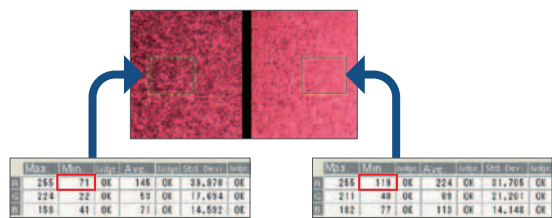

### Color extraction

Colors in different color phases can be simultaneously extracted and inspected by using one inspection checker.

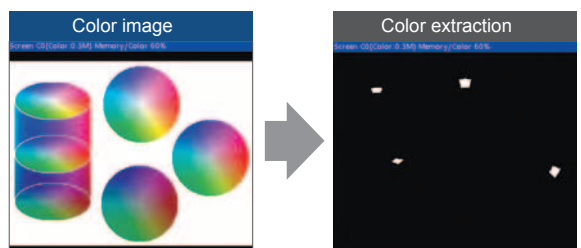

Purple and red orange is extracted.

## Branch execution/Designated execution Man-hour reduction

The inspections can be quickly changed to meet multiple product types or various conditions.

### Branch execution

Up to nine branches can be set to choose an inspection to be executed depending on the test results.

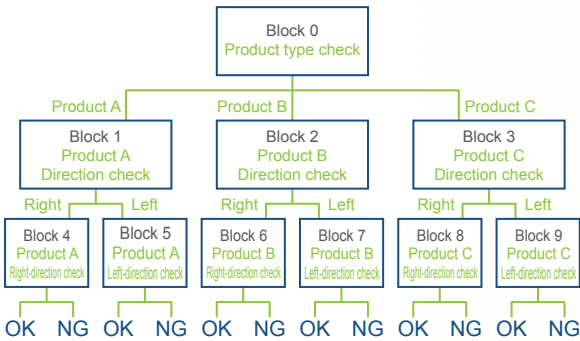

### Designated execution

After trigger signal is applied, up to ten different inspections can be executed immediately. This minimizes the time spent on switching product types.

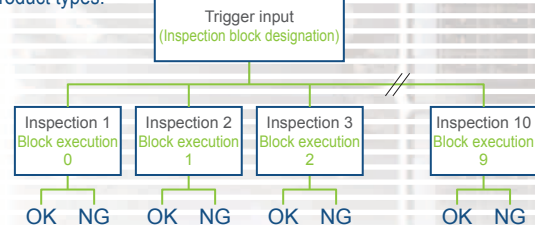

Inspection result of each block is stored until the next execution.

A dedicated application can be created by controlling the block execution timing externally.

### Applications

**Case 1** One work is moved and inspected numerous times then given a total judgment (inspection of target using split captures in order to obtain necessary resolution).

#### Total judgment result output with last block

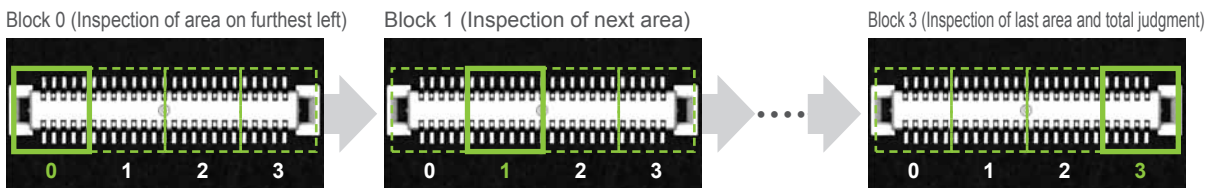

**Case 2** Imaging conditions are changed, work is inspected numerous times, and total judgment is made (lighting of light source is controlled by a PLC).

#### Result of Block 0 is used to inspect at Block 1.

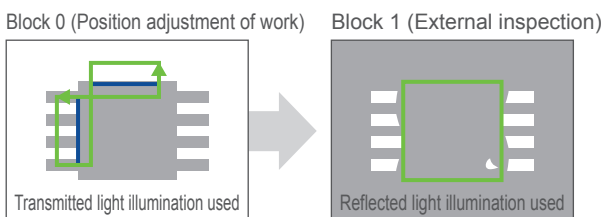

**Case 3** Simple alignment

#### Result of Block 0 is used to inspect at Block 1.

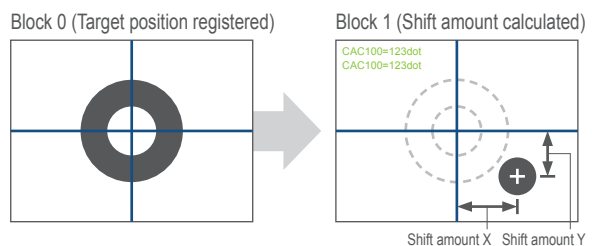

## Inspections of a variety of points of a variety of product types

- Data for up to 256 types can be saved in the built-in memory alone, and 25,600 types with an SD memory card inserted.
- Maximum registrable number of checkers: 1,000 checkers / type

Checker types	Line	Binary window	Grey window	Binary edge	Grey edge
	Feature extraction	Smart matching	Contour matching	Flaw detection	Color window
	Three connectors (binary window, grey window, and grey edge)			Smart edge (circles) / (line)	

A total of 15 types

- Maximum registrable number of templates: 2,000 templates
- Maximum available number of numerical calculation formulas: 1,000 formulas / type

A variety of operators for numerical calculation are available: Four fundamental operations (+, -, x, ÷), bracket operation, trigonometric function (14 types), comparison function (6 types), mathematical function (15 types), geometric function (18 types), and statistical function (18 types)

- Execution blocks: 10 blocks / type
- Position adjustment: 1,000 checkers / type, Area adjustment: 1,000 checkers / type



# Preprocessing

## Grey conversion / Color extraction

- Grey conversion: Max. 16 groups/camera

The conversion coefficients are set for the color image RGB greyscale value and the image is converted to grey. Each RGB coefficient can be set freely (-1,000 to +1,000). This makes it difficult for the inspection to be affected by color changes, such as by the removal of low saturation (low coloration) or non-color parts and by target color enhancement, caused by lighting fluctuations.

- Color extraction: Max. 128 colors/type (one camera, expansion mode)

Utilizing the parameters H (Hue), S (Saturation) and V (Value), which resemble the way humans perceive differences in color, multiple colors (max. 128 colors) can be extracted simultaneously.

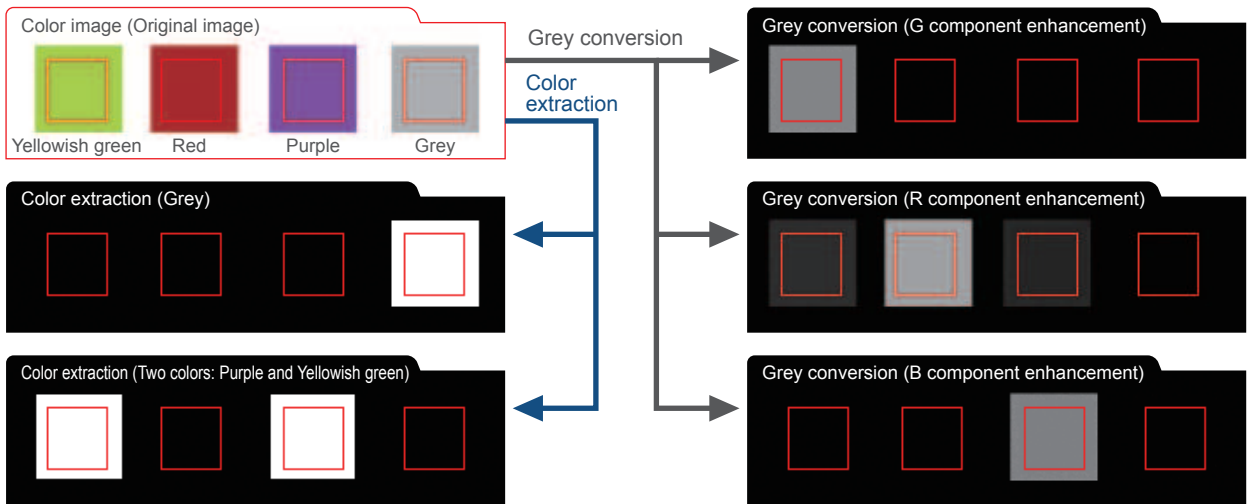

## Grey preprocess filters



21 types of grey preprocess filters are available. Reliable inspections are possible even under non-uniform lighting conditions or in the case of images with noise.

- Preprocess filters: 21 types
- Preprocess groups: Max. 16 groups/camera
- Preprocess steps: Max. 10 steps/group

Main purpose	Filter name
Flaw detection	• Tophat • Dynamic • Grey difference
Noise removal	• Dilation • Erosion • Erosion → Dilation • Dilation → Erosion
Image adjustment	• Rotation • Reflect

Main purpose	Filter name
Contour enhancement	• Sobel • Prewitt • Laplacian • Edge extraction X • Edge extraction Y • Sharpen
Blurring	• Median • Smoothing
Contrast enhancement	• Auto correction • Grey cut • Area averaging • Correction settings

Application example	Original image	Processed image
Checking container lids for adhesion of foreign substances <b>Filter used [ Tophat ]</b>		
Checking films / sheets for scratches / wrinkles <b>Filter used [ Grey difference, Area averaging ]</b>		
Detecting dirt on transparent sheets <b>Filter used [ Dynamic ]</b>		

Application example	Original image	Processed image
Extracting printed characters (deleting the background) <b>Filter used [ Dynamic ]</b>		
Checking the inside of containers for adhesion of foreign substances <b>Filter used [ Grey difference, Tophat ]</b>		
Checking sintered parts for breaks / cracks <b>Filter used [ Grey difference, Tophat ]</b>		

# Checker Functions

## Smart edge (Circle)/(Line)



Complicated inspection processes can be easily performed with highly accurate measurements.

A function for accurate approximation of circles/lines

This function detects a maximum of 3,000 edge points for a line and 3,600 for a circle in one area, dramatically improving the accuracy of the dimension and position measurements.

### Operation principle

1. A Grey edge scanning area is created, and edge points in the area are searched to detect the contour of the object.
2. Virtual circles and approximate straight lines can be identified with a high degree of accuracy based on the target edge points.
3. Pass (OK) /fail (NG) evaluations are made based on the measured values (radius, diameter, and width), deviations, circularity, straightness, and the number of edges outside the area.

### Smart edge (circle) setting example

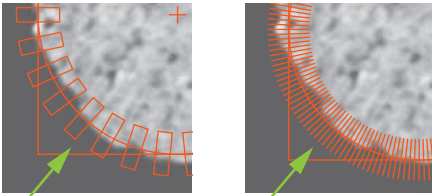

One cell can have a minimum width of one pixel (linear scanning), and a maximum of 3,600 cells can be set per 0.1°.

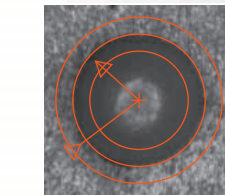

The center of the virtual circle, radius, diameter, circularity, and ring width can be measured.

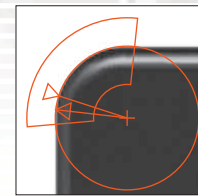

The center and radius of the corner are measured.

### Smart edge (line) setting example

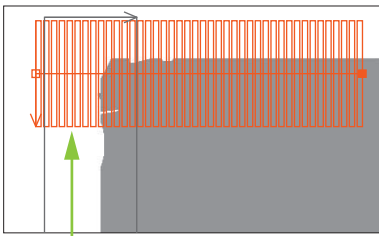

A maximum of 3,000 cells can be set.

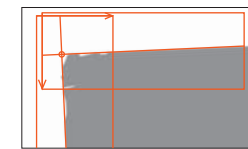

The influence of surface imperfections is eliminated to accurately detect the target straight line by approximation.

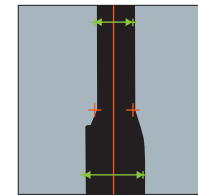

Imperfections along a target sample can be analyzed for maximum and minimum values.

## Geometry calculation

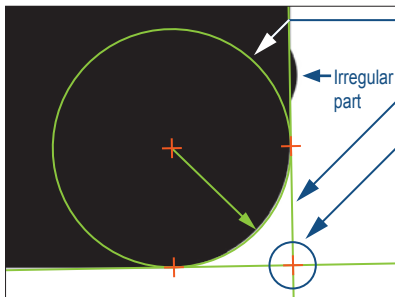

Virtual circle  
Approximate straight line  
Irregular part  
Intersection of two lines

Distances, intersections, and median lines can be detected.

This function detects the distance between two points, the intersection of two lines, the median line of two lines, the perpendicular distance, and an approximate ellipse. In combination with Smart edge (circle) / (line), this function recognizes the object as a geometric figure, allowing the coordinates, distances, dimensions, and angles to be obtained without preparing calculation formulas.

### Applications

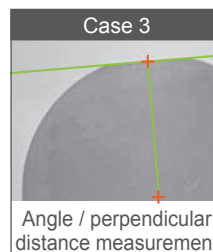
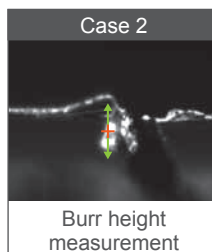
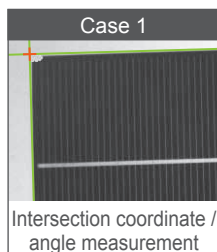



# Checker Functions

## Matching High accuracy inspection Min-hour reduction

By using the PV200 matching function, highly accurate detection is possible using two means of matching that take into account the characteristics of the target object and the process environment.

### Smart matching

#### Pattern search



Through means of a unique normalization process, stable detection can be achieved with reduced influence from grey fluctuations.

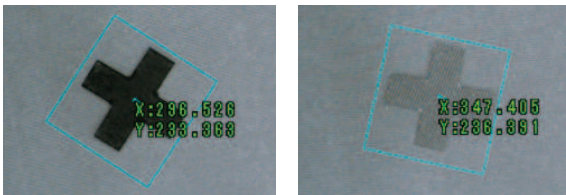

Detects even with low-contrast images

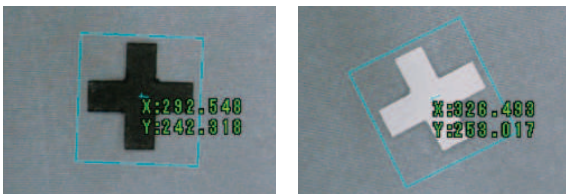

Detects even with negative images

#### Selection possible among multiple templates

A high-precision inspection is possible by searching a maximum of 64 templates in the same search area to detect a result with the highest correlation.

Template images

Template 0	Template 1	Template 2	Template 3	Template 4	Template 5

Object of search

After searching all templates, Template 3 with the highest correlation is used for detection.

#### Extraction of deviating portion using pattern difference

Based on the position information obtained by the matching function, the registered object and detected object are overlapped and compared on a pixel-by-pixel basis. Any pixels with a difference in brightness over a certain level are detected. The area value of such pixels can then be used to make pass/fail evaluations.

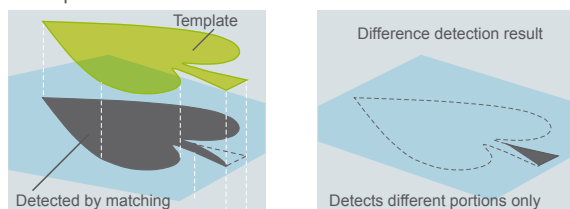

### Contour matching new

#### Contour search



A template is created from the contour information (object) obtained from the grey change points (edge points), which means stable detection can be achieved without being influenced by the object shape or changes to the background.

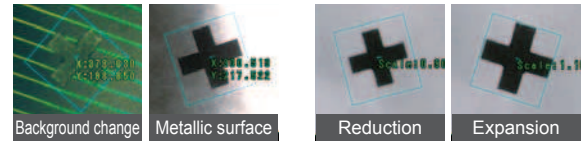

Detects even if background changes.

Even if all of detected target object is registered, detection will be stable regardless of the state of the background.

Detects even if the magnification changes (±10 % max.)

The same template can be used for detection even if in processes where the distance between the work and the camera changes.



Detects even if target object is hidden

Stable detection is possible even if part of the object being detected is deficient.

Detects even with noise on the target object

Stable detection is possible even if the part of the object being detected changed due to a limitation in the lighting or inspection process.

### Common template

- When a common template is used, the information of all checkers that use the same template will be updated with the switch of one template. Compared to the setting of templates individually, time is saved by reducing repetitious work and operational mistakes are prevented.
- Also, since it is not necessary to register the same template more than once, space for holding templates on the PV200 can be saved. Images registered as common templates can be used for both smart matching and contour matching.

## Flaw detection



This function is ideal for critical appearance inspections, such as scratches, stains, chipped edges, burrs, and other flaws in objects. The inspection is carried out by comparing a target's greyscale image with neighboring parts, which helps in the detection of minor scratches, stains, and chips.

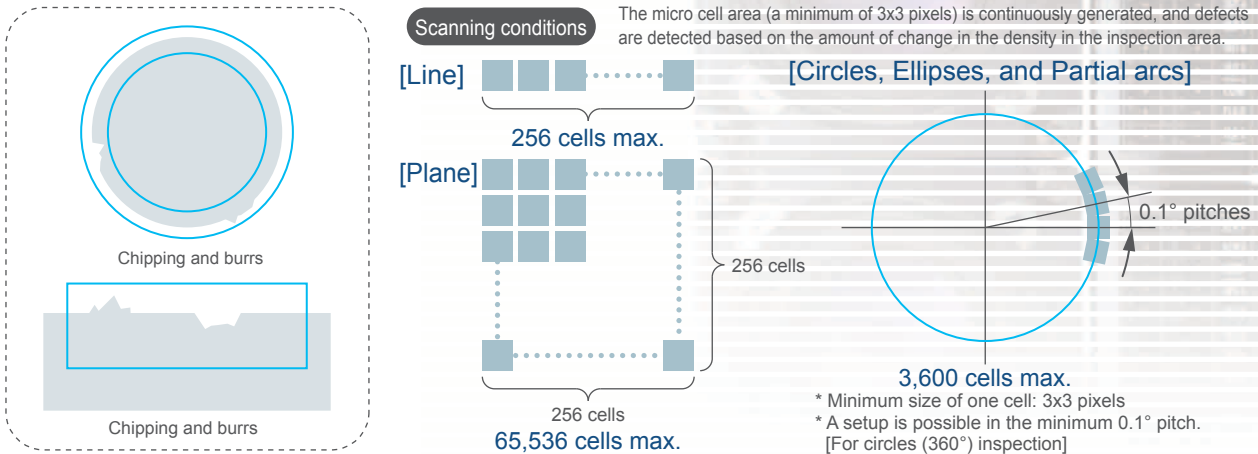

## Connector checker



Setup for connector inspection has been burdensome up to now. Now inspection can be accomplished by creating one area. This enables a great man-hour reduction.

### Inspection example

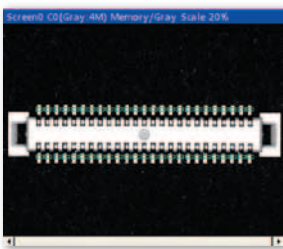

### Pin pitch inspection

This function measures the distance between the edges of each pair of adjacent pins and evaluates the results based on the preset upper and lower limits. Data of the "start point", "end point", and "number of pins" should be input.

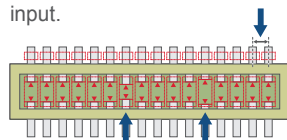

### Pin coplanarity inspection

This function detects raised pins. In the same way as the pin pitch inspection, setting simply adjusts the position using one checker and then inputting the number of pins.

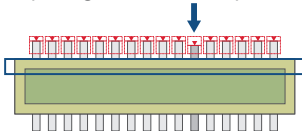

### Inside pin gap inspection

This function inspects the gap between facing ends of pins. Simply input the number of pins. The upper and lower limits of the gap can be set.

## Coordinate calibration



Setting and calculation is possible, linking the camera image with the actual dimensions.

### Link two images

Global coordinates between two cameras are generated and both results are quoted to enable direct calculation.

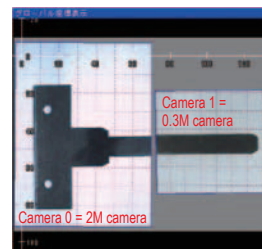

Calculation is possible mixing the separate detected data by two cameras.

### Dynamic calibration

Conveyance differences arising during stage and index conveyance are adjusted each time to enable stable measuring of the work dimensions.

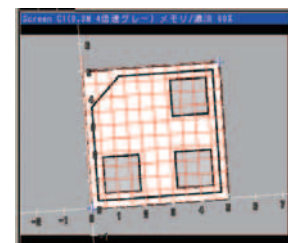
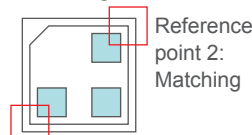

## Our unique algorithm for ultra high speed processing

Parallel processing by Quad processor and our unique algorithm ensure outstanding ultra high speed inspections.

[Execution processing speed]	Unit: msec		
Checker fuctions (Note 1)	640 × 480	1,600 × 1,200	2,048 × 2,048
Binary window	0.5	1.7	3.3
Grayscale window	0.4	1.5	2.9
Binary edge	2.1	11.3	23.7
Grayscale edge	8.7	54.0	117.2
Feature extraction	1.1	3.8	6.9
Smart matching (Note 2)	5.0	32.3	63.5
Contour matching (Note 3)	26.4	111.3	329.4

Notes: 1) The processing speed above is a reference value based on default settings. Processing speed vary depending on the image being inspected.

2) Template: 128 x 128, Without rotation

3) Template: 128 x 128, Rotation: ±30°, Scale: ±5°

4) When using a color camera.

[Execution processing speed]	Unit: msec		
Filter functions	640 × 480	1,600 × 1,200	2,048 × 2,048
5 × 5 Dilation	0.8	3.7	7.6
5 × 5 Erosion	0.8	3.7	7.6
5 × 5 Smoothing	1.2	5.8	13.1
5 × 5 Edge extraction X	0.8	3.3	6.6
5 × 5 Edge extraction Y	0.8	3.3	6.8
5 × 5 Prewitt	1.9	9.9	21.5
5 × 5 Sobel	1.9	10.5	21.7
Image rotation	1.9	11.5	24.8
Grey conversion (Note 4)	1.2	5.1	-
Color extraction (Note 4)	0.5	2.4	-



# Interface

## Operation screen Man-hour reduction

The PV200 has been designed to simplify implementation in both pre-production and post-production.

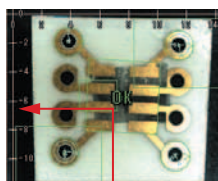

### Unit conversion axes

X and Y axes indicate the scale converted into the actual dimensions. (Separately settable for each camera)

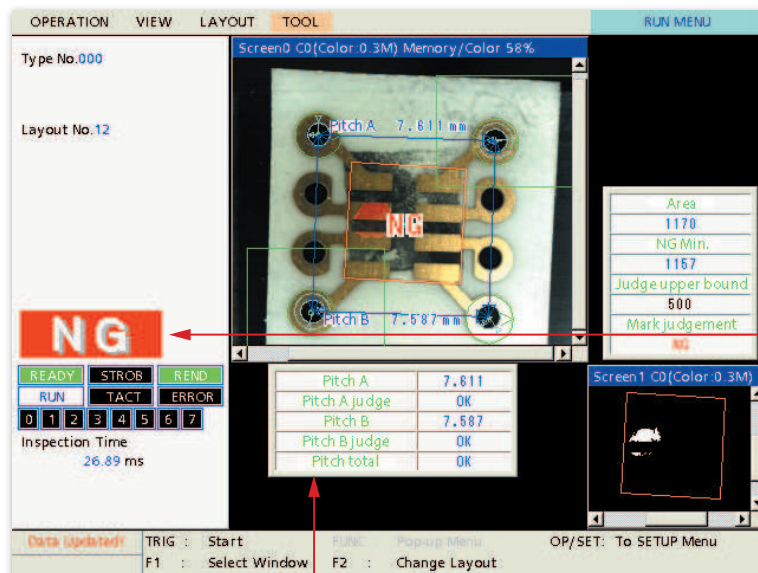

### Data R (Read) / W (Write) function

Program modifications can be quickly made in the RUN mode without replacing the program or switching to the setting screen. This is useful in cases where changes to the inspection area and pre-processing parameters must be made after the program has been finalized.

[Modification examples]

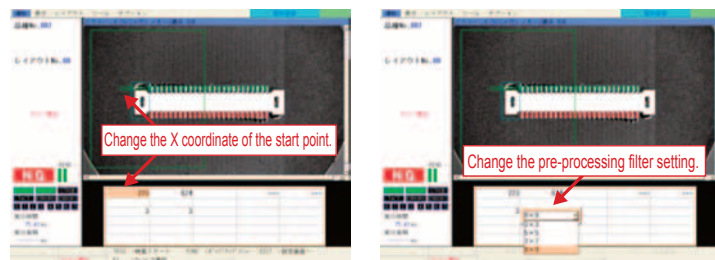

### Splash screen

The splash (startup) screen can be changed to an original screen, such as a screen suitable for the user's equipment or a screen including a brand logo. (A bitmap with a maximum size of 640 x 480 pixels)

### Operation customization by external signal

The PV200 is equipped with a total of five points for ASSIGN and EXTRA signals, which allow you to customize the allocations of tasks, such as layout switching, image data output and screenshot printing.

### Customizable Display new

#### Character / Figure drawing

A function for drawing text (multi-lingual), measured values, cross marks, arrow marks (dimension lines), rectangles, and ellipses. This function allows drawn items to be displayed following the calculation results or detected positions. It is also possible to specify the character size, fill regions and switch the drawn item colors or turn on/off the display of the items according to the pass/fail check results.

#### Marker function

A straight line, rectangle, circle, ellipse, and cross line can be displayed at any position. The display position can be specified by using external signal.

#### Layout

The VGA screen (640 x 480 pixels) can display two images and two pages of the Data R/W screen. Layouts can be customized and up to 16 patterns can be registered. They can be switched in accordance with the situation using either the keypad or external signals.

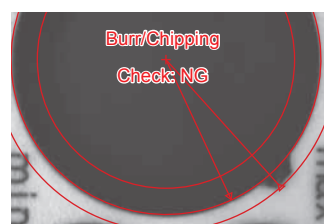
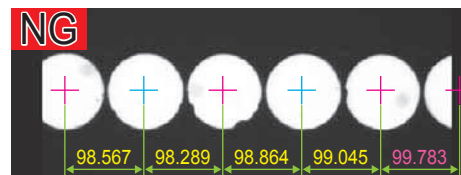

## Setup screen Man-hour reduction

### Select menu

new

By registering to the menu list any item you prefer from the items in the setup screen, you become able to perform operations directly, verify settings, and make changes.

- Improve operability by registering to the menu those functions you use a lot.
- Prevent operation mistakes by registering to the menu those functions that are okay to change.

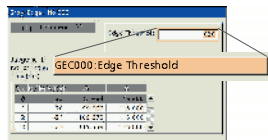

**Checker parameter registration**  
Only the set value and result are displayed when a checker parameter is chosen.

\*Parameters other than those items chosen are not displayed.

Number of registrations:  
max. 50 pages/product type (16 items/page)

### Password protection

Setting a password prevents the careless switching to the setup screen. The password can have a maximum of 15 digits (from 84 alphanumeric and symbol characters). By joint use with the Select Menu, it is possible to distinguish between operator and administrator use.



Select Menu

Limit switching to the regular setup menu.

Regular setup menu

### Collective moving of inspection areas

This function is essential to simultaneously move multiple inspection areas for the purpose of fine adjustment of the target position. The areas can be chosen by camera, position correction group, or inspection checker type.

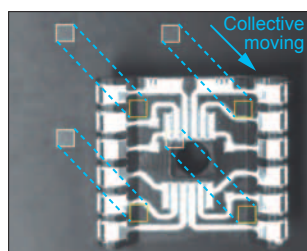

## PVWIN200 setup software Man-hour reduction

### User-friendly drag-and-drop operations

Drag the target image and drop it onto a PVWIN200 screen to start the operation. The guidance by the navigation view icons will help you set the inspection conditions.

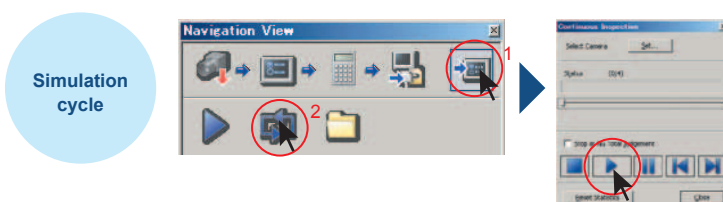

Simulation cycle

### Checker list

The checker list shows the on/off state of each inspection function and the inspection results so that users can check the program outline. It is possible to jump to the setting screen for a selected function and edit the settings.

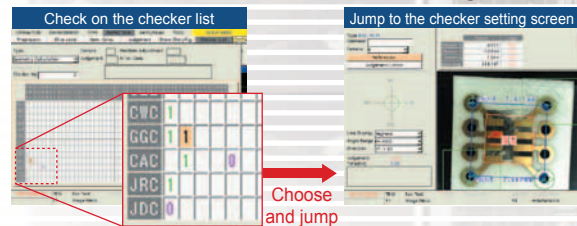

### Histogram

In the image preprocessing and the binarization setting screens, both the original image and its histogram are displayed as guidance for processing

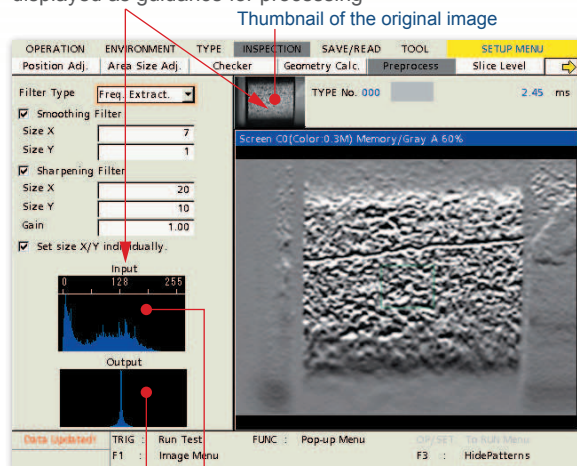

After processing Before processing

### Setting help

Various functions are built in that are useful when installing the PV200 at the worksite.

Setting help function

- Focus adjustment
- Communication test
- Aperture adjustment
- Parallel I/O test
- Grey data analysis
- Image capture delay adjustment

### Simulation cycle for debugging

The continuous simulation and data logging functions facilitate setting data corrections and verifications. The export function allows you to manage the setting data change history.

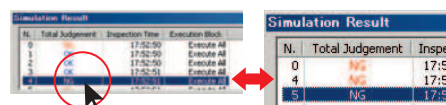

Can be switched to the screen displaying "NG" items only

Download PVWIN for free from:

<http://panasonic-electric-works.net/sunx>

PV200 Setup Software  
IMAGECHECKER  
**PVWIN200**



# Interface

## Communication Man-hour reduction

### PLC communication

By simply setting the register address of the PLC or other equipment you are using with the device, it is possible to receive PV200 results and perform command operations.

#### Result output

By using the PLC communications function, the PV200 results can be written directly to the PLC register without a communications program.

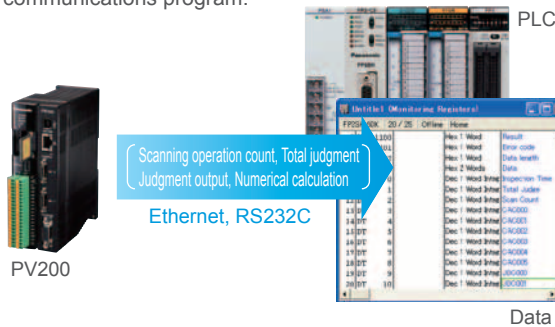

#### Command processing new

PV200 external command control is possible by operating the PLC register values without a communications program.

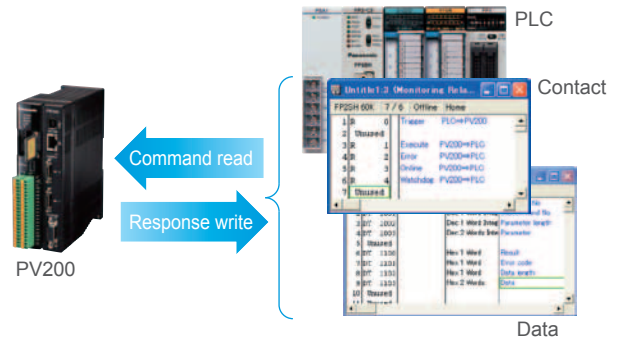

### High-speed communications and storage (Built-in memory / Ethernet / SD memory card)

#### Inspection and judgement result data output new

- Compatible with parallel I/O, RS232C (115.2 kbps), Ethernet (Gigabit). The RS232C PLC communications are now compatible with Modbus RTU.

#### Image data

- Up to 312 images captured by the 0.3M camera, 39 images captured by the 2M camera and 14 images captured by the 4M camera can be stored in the built-in memory in real time (without increasing the processing time).<sup>\*1</sup>
- A 32 GB SD memory card can store a maximum of about 90,000 images captured by the 0.3M camera, about 16,500 images captured by the 2M camera or about 7,600 images captured by 4M camera.<sup>\*2</sup>
- The Gigabit Ethernet LAN port allows image transfers at three to five times the speed of 100-Megabit Ethernet. Via this port, one image captured by the 0.3M camera can be transferred in 80 msec.<sup>\*3</sup>



Conventional model (PV310)	Transfer time
100-Megabit Ethernet	
<b>PV200</b>	Transfer time
Gigabit Ethernet	

\*1: When one camera is connected. \*2: Color camera images: Bayer format  
\*3 Depends on the connected equipment.

### Multiple simultaneous output to external devices.

Judgement results and numerical result data can be simultaneously output to RS232C and Ethernet interfaces, and to SD/SDHC memory cards. For example, the data for traceability and inspection control can be simultaneously output.

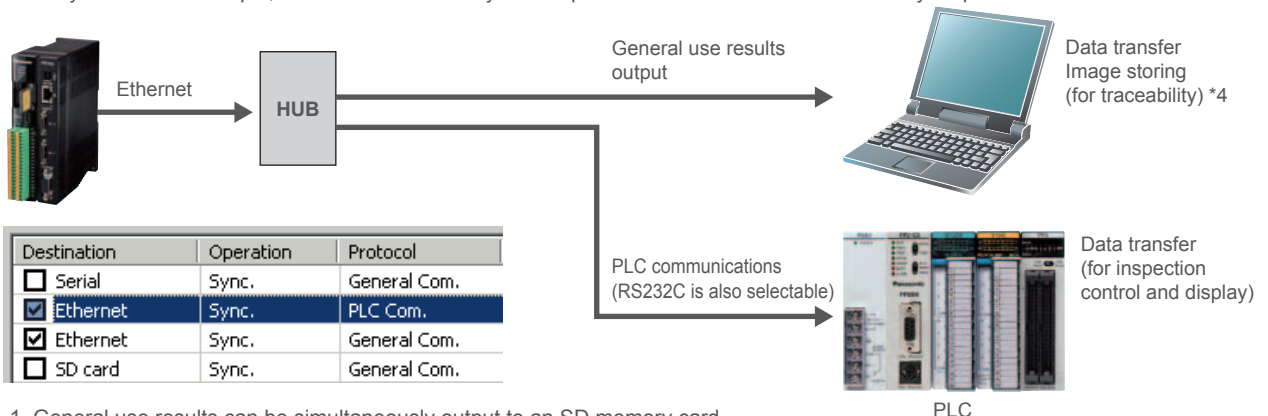

- General use results can be simultaneously output to an SD memory card, RS232C and Ethernet interfaces.
- Ethernet can be used at the same time for output of general use results and PLC communications.

\*4 The free software "Image Receiver for PV" is used.

# Specifications

## General specifications

Item	Specifications
Rated operating voltage	24 V DC
Operating voltage range	21.6 to 26.4 V DC (including ripples)
Rated current consumption	1.2 A max.
Ambient temperature during use	0 to +45 °C 32 to +113 °F (no freezing or condensation)
Storage ambient temperature	-20 to +60 °C -4 to +140 °F (no freezing or condensation)
Ambient humidity during use	35 to 85 % RH (at 25 °C 77 °F, no freezing or condensation)
Storage ambient humidity	35 to 85 % RH (at 25 °C 77 °F, no freezing or condensation)
Noise immunity	1,000 V, Pulse width: 50 ns, 1 μs (using the noise simulator method)
Vibration resistance	10 to 55 Hz, 1 sweep/min, double amplitude of 0.75 mm 0.03 in, 30 minutes each in the X, Y, and Z directions
Shock resistance	196 m/s <sup>2</sup> , 5 times each in the X, Y and Z directions
Insulation resistance (initial value)	100 MΩ or higher (measured by a 500 V DC megger) *1 Input and output terminals – Power and ground terminals Input and output terminals – Non-energized metal part Power terminal – Non-energized metal part
Breakdown voltage (initial value)	500 V AC for 1 min (600 V AC for 1 sec), Cutoff current: 10 mA *1 Input and output terminals – Power and ground terminals Input and output terminals – Non-energized metal part Power terminal – Non-energized metal part
Battery life	10 years approx. (at 25 °C 77 °F)
Weight	0.5 kg approx. (including terminal blocks)
Pollution degree	Pollution degree 2

\*1 The evaluation was carried out with the primary side power supply varistor and capacitor removed from the internal circuit of the unit.

## Functional specifications

Item	Specifications		
CPU	32-bit, RISC CPU & DSP		
Input/output	Cameras	Up to two cameras selected from among 0.3M grey/grey compact/color cameras (640 x 480) and 2M grey/color cameras (1,600 x 1,200) can be connected. *2 Up to two 4M grey cameras can be connected. *2	
	Monitor output	VGA (640 x 480) output	
	Memory card	SD/SDHC memory card	
	PLC communication compatible models (RS232C)	Panasonic Electric Works SUNX	FP series
		OMRON	C, CV, and CS1 series
		Mitsubishi Electric	A, Q, FX, and FX2N series
		Fuji Electric	MICREX-SX SPH series
		Allen-Bradley	SLC500 series
		Modbus RTU compatible (performance confirmed with Siemens S7-1200)	
	PLC communication compatible models (Ethernet)	Panasonic Electric Works SUNX	FP series, ET-LAN unit
	Mitsubishi Electric	Q series	
PLC communication command	Specifiable external command instruction using PLC communication Command input format: polling / parallel input		
Parallel	14 inputs / 15 outputs		
Keypad input	Connector for dedicated keypad (ANPVP**), 1 channel		
USB	USB 2.0, A-B type (Only PWIN200)		
Menu display	Four languages (five fonts), Switchable (Japanese, English, Korean, Traditional Chinese and Simplified Chinese)		
Monitor display (VGA)	Split-screen display of up to two camera images, Zoom function (2 to 400%)		
	Image display: Through/Memory/NG object images Display effects: Greyscale/Slice level group/Preprocessing group/Color/Extraction and binary/Grey conversion image, Display area (640 x 480)		
Processing methods	Greyscale processing/Thresholding processin/Color extraction/Grey conversion		
Processing resolution	2M camera (grey/color): 1,600 horizontal x 1,200 vertical pixels		
	0.3M camera (grey/grey compact/color): 640 horizontal x 480 vertical pixels		
	4M camera (grey): 2,048 horizontal x 2,048 vertical pixels		
Trigger input	Select from: All cameras or detection trigger		
Number of connected cameras	Up to two cameras		
Camera connection	Connection by Power Over Camera Link (PoCL)		
Capture method	Frame shooting only. Capable of partial capture of one point		
	In partial capture mode, the minimum capture area to be set for the 0.3M/4M camera is one line, and that for the 2M camera is 100 lines. (The area can be set in increments of one line for the grey camera, and two lines for the color camera.)		
Shutter speed	30 μs to 1,000 ms (Set in increments of 10 μs)		
Gain setting range	1.0 to 5.0		
Number of product types	256 types max. (depends on setting data)		
Password	Switching from the current operating screen to the setup screen can be password controlled (within 15 characters). Administration classification: invalid/valid (limit setting screen transition and limit regular menu switching)		
Inspection functions (Checkers)	1,000 checkers/product type max., including those for geometry calculation and character/figure drawing (depends on setting data)		
	Position adjustment, Position rotation adjustment, Rotation adjustment area size adjustment, Line, Binary window, Grey window, Binary edge, Grey edge, Feature extraction, Smart matching, Contour matching, Flaw detection, Connector (binary window), Connector (grey window), Connector (grey edge), Smart edge (circles), Smart edge (line), Color window		
	* Number of range masks: 16 ranges/checker * Maximum registrable number of smart matching and contour matching templates: 2,000 pcs.		
Geometry calculation	1,000 checkers/product type max., including those for inspection functions and character/figure drawing (depends on setting data) Seven calculation functions (distance between two points, intersection of two lines, median lines of two lines, perpendicular distance, approximate straight line, approximate circle, and approximate ellipse)		
Character/figure drawing	Up to 10,000 characters/graphics (1,000 checkers x 10)/product type can be displayed on the images (depends on setting data).		
Inspection operation mode	Sequential processing: After completing the result output, the next image capture for inspection can be started.		
	Parallel processing: After the capture and the synchronized output of results of the previous inspection are completed, the image capture process for the next inspection is ready to start, and then the capture and inspection results output are processed concurrently.		
Slice level group	16 group/camera, 256-grey scale (0 to 255)		

## Functional specifications

Item	Specifications				
Image preprocessing	Preprocessing selections: Grey conversion / Color extraction / Grey preprocessing				
	Grey conversion	Available only when a color camera is connected. For each product type, 16 groups/camera Each R/G/B value setting for grey conversion can be changed within the range of -1,000 to 1,000.			
	Color extraction	Available only when a color camera is connected. Color extraction mode: Selectable between high speed and expansion Number of extractable colors: High speed: A total of 16 colors when one camera is connected and eight colors when two cameras are connected. Expansion: A total of 128 colors when one camera is connected and 64 colors when two cameras are connected. Only eight registered colors can be selected from one checker.			
Grey preprocessing	For each product type, 16 groups/camera, 10 stages max. Preprocessing filters: 21 types (Dilation, Erosion, Erosion → Dilation, Dilation → Erosion, Auto correction, Grey cut, Area averaging, Correction settings, Median, Smoothing, Sobel, Prewitt, Laplacian, Edge extraction X, Edge extraction Y, Sharpen, Tophat, Dynamic, Grey difference, Rotation, and Reflect)				
	1,000 formulas/product type max., including those for judgement output (depends on setting data) Calculations involving output values of inspection functions				
Numerical calculation	Operators	Four fundamental operations (+, -, x, /), Bracket operations, Trigonometric functions (14 types), Comparison functions (6 types), Math functions (15 types), Geometry functions (18 types), Coordinate conversion functions (8 types)			
	Statistic data operation items	Scan count/OK count/NG count/Average/Variance/Max./Min./Range/OK average/OK variance/OK judgment max./OK judgment min./OK range/NG average/NG variance/NG judgment max./NG judgment min./NG range User limit: 1,000 items /product type max.			
	Other operation items	Previous data of numerical calculation and judgment results, general-purpose registers			
	Number of reference operators	16 items/formula max.			
Judgement output	1,000 formula/product type max., including those for numerical calculation (depends on setting data) Substitution for and logical calculation of judgement results from checkers and numerical calculations				
	Operators	NOT/AND/OR/XOR/Brackets			
	Number of reference items	16 items/formula max.			
	Others	Total judgment conditions, save image conditions, Image output conditions, parallel output setting (8 outputs from OUT0 to OUT7 and 16 outputs from OUT0 to OUT15, or all setting output)			
Collective moving	Collective movement of set checkers in units of position/rotation adjustment groups Specify the "Move" or "Not move" option for each checker type. Position and rotation adjustment checkers cannot be moved.				
Marker	8 markers/product type max. for each camera. Graphic display on the operation screen, Selectable from six colors				
	Shapes	Rectangle/Circle, Ellipse/Polygon/Line/Cross			
Data R/W	Two-window display of up to 80 (5x16) cells/product type on screen in table form in RUN mode Substitution of title input, checker conditions/results, numerical calculation results, numerical calculation judgment results, judgment results, statistical results possible. Change of upper/lower limits of numerical computation in the table in RUN mode possible.				
Select menu	Maximum registrable number of arbitrary setup items in setup screen on menu: 16 items x 50 pages/type.				
	Registration information	Button / Text / Page move / Separator			
	Button allocation method	FUNC key for item / Selection from list			
Others	Page name registration possible				
Calibration	Coordinates, coordinate origin, horizontal and vertical coefficients can be set for each camera to obtain actual dimensions for each product type.				
	Processing method	Unit conversion / 1 point coordinate conversion / 2 point coordinate conversion / 3 points coordinate conversion			
	Operation method	Static / Dynamic			
Standard registration	Arbitrary position / Smart matching / Contour matching / Intersection / Centre of circle / Feature extraction				
Conversion data	Coordinates, coordinate origin, horizontal and vertical coefficients can be set for each camera to obtain actual dimensions.				
Others	Comment input				
Template re-registration settings	Position	Set position/Adjusted position			
Display	Yes/No				
Normal execution	Execution of all checkers				
Execution mode	Branch execution	Destination blocks (0 to 9) can be set.			
	Designated execution	Blocks to be executed (0 to 9) can be set.			
External input/output functions *3	○: Applicable, ✕: Inapplicable	Parallel	Serial	Ethernet	SD memory card
	Inspection start instruction	○	○	○	—
	Re-inspection start instruction	○	○	○	—
	Product type change instruction	○	○	○	—
	Template re-registration instruction	○	○	○	—
	Display layout switch instruction	○	○	○	—
	Operation/stop switch instruction	○	○	○	—
	Statistics reset instruction	○	○	○	—
	Error reset instruction	○	○	○	—
	Instruction to save setting data in the built-in memory	○	○	○	—
	Instruction to save setting data in the SD memory card	○	○	○	—
	Instruction to read setting data from the built-in memory	○	○	○	—
	Instruction to read setting data from the SD memory card	○	○	○	—
	Instruction to cancel the saving/reading of setting data	○	○	○	—
	Instruction to save the image memory in the SD memory card	○	○	○	—
	Instruction to erase the image memory	○	○	○	—
	Instruction to print the screenshot	○	○	○	—
	Inspection/processing cancellation instruction	○	○	○	—
	Instruction to save the latest inspection image	○	✕	✕	—
	Instruction to read/change the set value	✕	○	○	—
Instruction to prohibit the keypad screen operation	✕	○	○	—	
Keypad emulation instruction	✕	○	○	—	
PLC communication command read instruction	○	✕	✕	—	
Output	Scanning operation count	○	○	○	○
	Total judgement output	○	○	○	○
	Judgement calculation (JD) result output	○	○	○	○
	Numerical calculation result output	○	○	○	○
	Image output	✕	✕	○ *4	○
	Screenshot output	✕	✕	○ *4	○

Specifications for PV200 firmware Ver. 1.3.

\*2 The 4M grey camera cannot be used in combination with another type of camera.

The ANPVC82\* dedicated compact camera cable is required to connect the compact cameras.

\*3 USB cannot be used for the external input/output functions.

\*4 Image and screenshot output functions via Ethernet are received by dedicated software, Image Receiver for PV.



# System Configuration

Equipped with a full selection of interfaces essential for image processing devices of the future



SD memory card (SDHC compatible)



Keypad

Serial (RS232C)

Parallel I/O

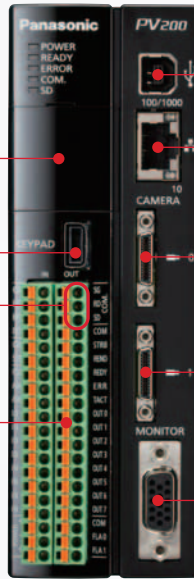

USB2.0

Gigabit Ethernet connector

Cameras (Digital cameras)

Up to two cameras of two different types can be connected.

0.3M color camera  
2M color camera



0.3M grey camera  
0.3M grey compact camera  
2M grey camera  
4M grey camera



\*The 4M camera cannot be used in combination with another type of camera.



VGA monitor output



## Product List

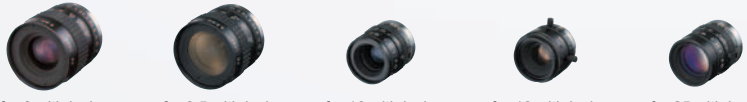

### Controller unit / Cameras / Keypads / Monitor / Camera attachment bracket

<b>PV200 IMAGECHECKER</b> Controller unit  [2-camera type] ANPVC202ADP	<b>Digital cameras for PV200</b> 0.3M color camera (Quad-speed) ANPVC2040  2M color camera ANPVC2260  0.3M grey camera (Quad-speed) ANPVC1040  0.3M grey compact camera (Triple speed) ANPVC5030  2M grey camera ANPVC1210  4M grey camera ANPVC1470 	<b>Keypads</b>  3 m 9.8 ft type: ANPVP03 10 m 32.8 ft type: ANPVP10	<b>Camera cables for PV200</b>  3 m 9.8 ft type: ANPVC8103 5 m 16.4 ft type: ANPVC8105 10 m 32.8 ft type: ANPVC8110
---	---	---	--

<b>Cable for PV200 compact camera (for ANPVC5030)</b>  3 m 9.8 ft type: ANPVC8203 5 m 16.4 ft type: ANPVC8205 10 m 32.8 ft type: ANPVC8210	<b>Flexible camera cables</b>  3 m 9.8 ft type: ANPVC8103R 5 m 16.4 ft type: ANPVC8105R 10 m 32.8 ft type: ANPVC8110R	<b>0.3M camera lenses</b>  f = 6 with lock ANB842NL f = 8.5 with lock ANB843L f = 16 with lock ANB845NL f = 16 with lock ANM88161 f = 25 with lock ANB846NL
---	--	---

<b>0.3M camera lenses</b>  f = 25 with lock ANM88251 f = 50 with lock ANB847L f = 50 with lock ANM88501	<b>2-megapixel camera lenses</b>  f = 16 ANPVL162 f = 25 ANPVL252 f = 50 ANPVL502	<b>Adapter rings (for the 0.3M cameras and 2-megapixel cameras)</b>  5 mm 0.20 in x 1 ring ANB84805 40, 20, 10, 5, 1, 0.5 mm 1.57, 0.79, 0.39, 0.20, 0.04, 0.02 in x 1 ring ANB848
--	--	--

### LED lighting equipment for image processing

<b>XGA monitor</b>  10.4 inches ANPVM11021	<b>Monitor cables</b>  3 m 9.8 ft type: ANMX83313 5 m 16.4 ft type: ANMX83315	<b>Camera attachment bracket (For 4M grey camera)</b> ANPVC005	<b>Digital power supply units for LED lighting</b>  10 W ANB86001 30 W ANB86003
---	---	---	--

# Dimensions (Unit: mm in)

## Controller unit / Monitor / Cameras / Keypads

### ● Controller unit ANPV0202ADP, ANPV0202MC

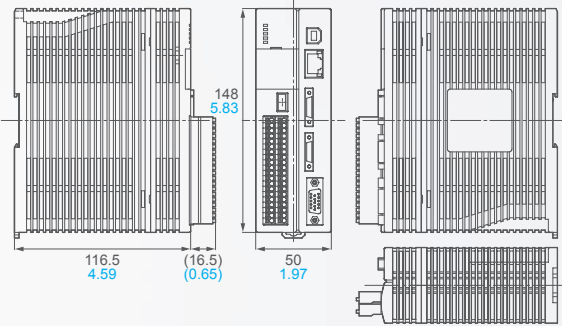

### ● 0.3M color and grey cameras ANPVC2040, ANPVC1040

### ● 2M color and grey cameras ANPVC2260, ANPVC1210

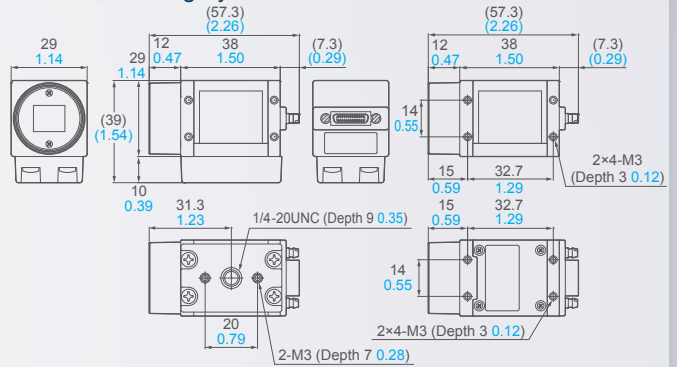

### ● XGA monitor ANPVM11021

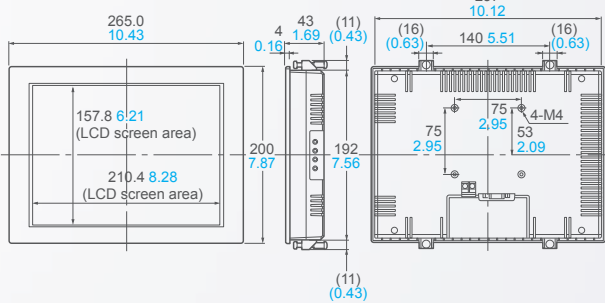

### ● 0.3M grey compact camera ANPVC5030

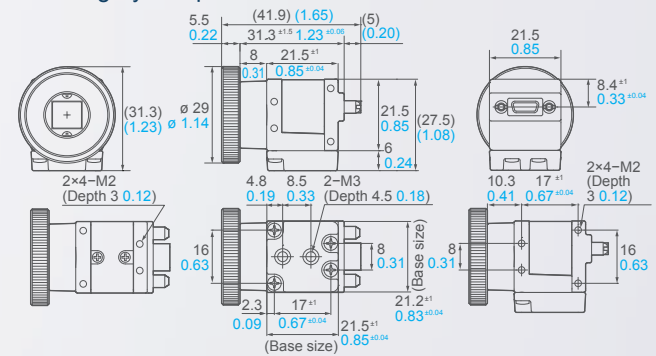

### ● Operation keypad ANPVP\*\*

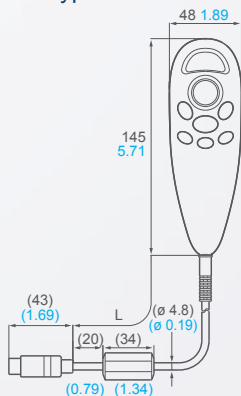

### ● 4M grey camera ANPVC1470

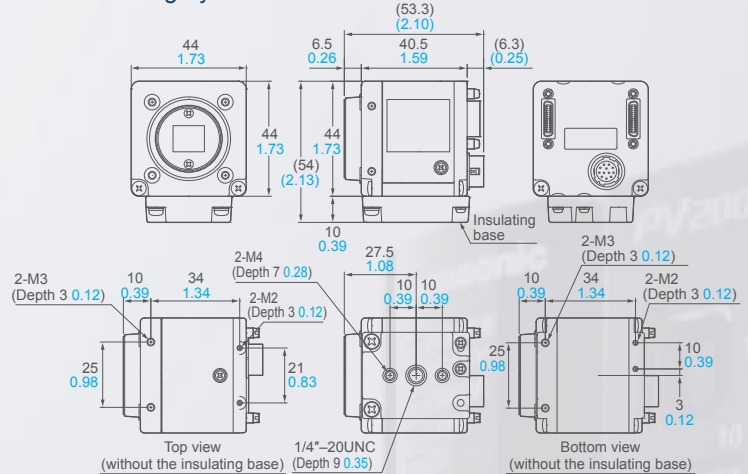

### ● Lenses for camera (Unit: mm in)

	0.3M camera lenses								2-megapixel camera lenses		
	f = 6	f = 8.5	f = 16	f = 25	f = 50	f = 16	f = 25	f = 50			
F-number	1.2	1.5	1.4	1.4	1.4	1.6	1.4	2.8	1.4	1.4	2.8
∅ A	42 1.65	42 1.65	31 1.22	30.5 1.20	31 1.22	30.5 1.20	48 1.89	30.5 1.20	34 1.34	34 1.34	34 1.34
L	46 1.81	40 1.58	33 1.30	31.21 1.23	37.3 1.47	31.5 1.24	48 1.89	38.5 1.52	35.9 to 38.0 1.41 to 1.50	47.1 to 52.2 1.85 to 2.06	63.0 to 77.4 2.48 to 3.05
B	- *1	- *1	- *1	21 0.83	- *1	21 0.83	- *1	21 0.83	22.5 0.89	22.5 0.89	22.5 0.89
C	- *1	- *1	- *1	19.8 0.78	- *1	20.05 0.79	- *1	20.6 0.81	22 0.87	22 0.87	22 0.87

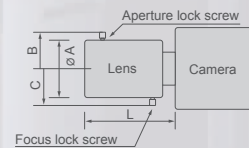

\*1 The projection of the lock screw (M1.4 pan-head machine screw) is a maximum of 2 mm 0.08 in.

### ● Camera attachment bracket (For 4M grey camera) ANPVH005

Please refer to <http://panasonic-denko.co.jp/ac/e/fasys>

## LED lighting equipment for image processing

### ● Digital power supply units for LED lighting

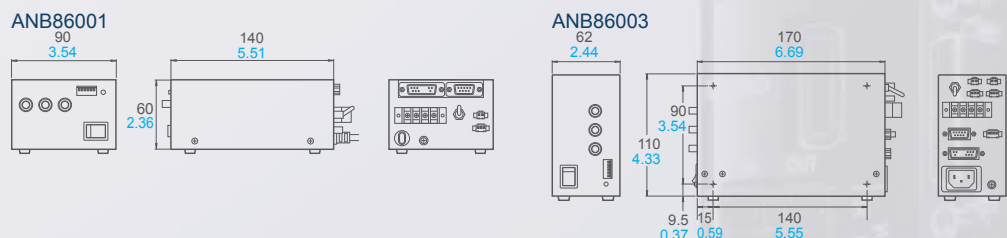



# Product Lineup

Function item		PV200					PV200 MC		PV500V2		
Controller unit		Color and greyscale combination					High speed grey processing		High speed, high productivity		
		 <p>new</p>					 <p>new</p>				
		Image processing with top-level accuracy in its class is available with a surprisingly small number of man-hours required for programming.					0.3M grey compact limited edition special value camera with all the functions of the PV200.		<p>"4 + 1" Penta processor enables extremely fast parallel processing. Verification of NG (failed) images and program corrections are possible while inspecting all items without stopping the production line.</p>		
Number of connected cameras max.		2					2		4		
Camera	Pixel	0.3M	2M	0.3M	2M	4M	0.3M (Note 2)		0.3M	2M	
	Grey/Color	Color		Grey			Grey		Grey		
	Shutter speed	30 μs to 1,000 ms (Set in increments of 10 μs)					100 μs to 500 ms (Set in increments of 10 μs)		30 μs to 1,000 ms (Set in increments of 10 μs)		
Monitor display		VGA					VGA		XGA		
Processing methods		Color, Greyscale, Binary					Greyscale, Binary		Greyscale, Binary		
No. of product types max. (Note 1)		256 types					256 types		25,600 types		
Maximum settable number of checkers (Note 1)		1,000 checkers/product type max.					1,000 checkers/product type max.		1,000 checkers/product type max.		
Major inspection functions (Checkers)	Position adjustment, Position/rotation adjustment	<input type="radio"/>					<input type="radio"/>		<input type="radio"/>		
	Area size adjustment	<input type="radio"/>					<input type="radio"/>		<input type="radio"/>		
	Binary window/Binary edge	<input type="radio"/>					<input type="radio"/>		<input type="radio"/>		
	Feature extraction	<input type="radio"/>					<input type="radio"/>		<input type="radio"/>		
	Character recognition (neural network)	—					—		—		
	Grey window/Grey edge	<input type="radio"/>					<input type="radio"/>		<input type="radio"/>		
	Smart matching	<input type="radio"/>					<input type="radio"/>		<input type="radio"/>		
	Contour matching	<input type="radio"/>					<input type="radio"/>		—		
	Flaw detection	<input type="radio"/>					<input type="radio"/>		<input type="radio"/>		
	○ : Applicable model	Connector (binary window, grey window, grey edge)	<input type="radio"/>					<input type="radio"/>		<input type="radio"/>	
		Smart edge (circles) / (line)	<input type="radio"/>					<input type="radio"/>		<input type="radio"/>	
		Geometry calculation	<input type="radio"/>					<input type="radio"/>		<input type="radio"/>	
	Character/Figure drawing	<input type="radio"/>					<input type="radio"/>		<input type="radio"/>		
	Others										
Numerical calculation/Judgment output		1,000 formula/product type max.					1,000 formulas/product type max.		1,000 formula/product type max.		
Data R/W		160 data					160 data		320 data		
Execution mode	Execution all	Execution of all checkers					Execution of all checkers		Execution of all checkers		
	Branch execution	0 to 9 can be set.					0 to 9 can be set.		0 to 9 can be set.		
	Designated execution	0 to 9 can be set.					0 to 9 can be set.		0 to 9 can be set.		
Password protection		<input type="radio"/> (Select menu)					<input type="radio"/> (Select menu)		<input type="radio"/>		
Image preprocess/Image conversion		Preprocessing filters: 21 types, for each product type 16 groups/camera, 10 stages max.					Preprocessing filters: 21 types, for each product type 16 groups/camera, 10 stages max.		Preprocessing filters: 21 types, for each product type 5 groups/camera, 10 stages max.		
Others									Program editing/testing in RUN mode		
Interface	RS232C	1 port					1 port		1 port		
	Ethernet	<input type="radio"/>					<input type="radio"/>		<input type="radio"/>		
	SD/SDHC	<input type="radio"/>					<input type="radio"/>		<input type="radio"/>		
	USB	<input type="radio"/>					<input type="radio"/>		<input type="radio"/>		
	Parallel input/output	14 inputs, 15 outputs					14 inputs, 15 outputs		PHOENIX terminal: 14 inputs, 15 outputs MIL terminal: 32 inputs, 32 outputs		
Setup tool software		Vision PVWIN200 Off-line simulation					Vision PVWIN200 Off-line simulation		Vision PVWIN Off-line simulation		
Recommended monitor (cable)		ANPVM11021 (ANMX83313)					ANPVM11021 (ANMX83313)		ANPVM11021 (ANMX83313)		

Notes:  
1) Depend on the setting data size. 2) Only 0.3M grey compact camera can be connected.



Function item		A230	A210V2 / A110V2	PD60 / PD65	
Controller unit		<div style="border: 1px solid black; border-radius: 15px; padding: 2px; display: inline-block;">Optical character recognition &amp; character checker type</div>	<div style="border: 1px solid black; border-radius: 15px; padding: 2px; display: inline-block;">General grey type</div>	<div style="border: 1px solid black; border-radius: 15px; padding: 2px; display: inline-block;">2D Code Reading Sensor</div>	
		 Fully equipped with advanced character recognition and character check functions	 Outstanding machine vision with a compact body loaded with excellent features and offering top-notch performance	 Compliant with international standards Featuring a 2D code print quality verification function	
Number of connected cameras max.		2	2 / 1	1	
Camera	Pixel	0.24M	0.24M	0.1M	
	Grey/Color	Grey	Grey	Grey	
	Shutter speed	30 μs to 1,000 ms (Set in increments of 10 μs)	30 μs to 1,000 ms (Set in increments of 10 μs)	30 μs to 50 ms	
Monitor display		NTSC	NTSC	Dedicated tool	
Processing methods		Greyscale	Greyscale, Binary	Binary	
No. of product types max.		32 types	64 types/32 types	7 types	
Maximum settable number of checkers		8 checkers/product type (character recognition)	96 checkers/product type	1 checker/product type	
Major inspection functions (Checkers)	Position adjustment, Position/rotation adjustment	○	○ / — (Position adjustment)	—	
	Area size adjustment	—	—	—	
	Line	—	○	—	
	Binary window/Binary edge	—	○	—	
	Grey window/Grey edge	○	—	—	
	Feature extraction	○	○	—	
	Smart matching	○	○ / —	—	
	Contour matching	—	—	—	
	Flaw detection	—	—	—	
	○ : Applicable model	Connector (binary window, grey window, grey edge)	○ (Lead inspection)	—	—
		Smart edge (circles) / (line)	—	—	—
		Geometry calculation	—	—	—
		Character/Figure drawing	—	—	—
		Others	Character checker Up to five dictionaries		2D code reading <div style="border: 1px solid black; padding: 2px; display: inline-block;"> <ul style="list-style-type: none"> <li>• Data matrix (ECC200)</li> <li>• QR code</li> <li>• Micro QR code</li> </ul> </div>
Numerical calculation/Judgment output		96 per product type	96/48 per product type	—	
Data R/W		20 data (data monitor)	20 data (data monitor)	—	
Execution mode	Execution all	Execution of all checkers	Execution of all checkers	Execution of all checkers	
	Branch execution	Two branch inspection based on the results of block 1	Two branch inspection based on the results of block 1	—	
	Designated execution	Block 1 to 3 can be set.	Block 1 to 3 can be set.	With retry function	
Password protection		○ (Hiding)	○ (Hiding)	—	
Image preprocess/Image conversion		—	—	Preprocessing filters: 14 types, 10 stages max.	
Others				Integrated lens and lighting unit Protective construction: IP67G Stationary type: PD60 Handy type: PD65	
Interface	RS232C	2 ports	2 ports	1 port	
	Ethernet	—	—	—	
	SD/SDHC	—	—	—	
	USB	—	—	○	
	Parallel input/output	11 inputs, 14 outputs	11 inputs, 14 outputs	3 inputs, 3 outputs	
Setup tool software		Vision backup Tool (Data saving)	Vision backup Tool (Data saving)	PDTOOL	
Recommended monitor (cable)		ANMA811 (ANM87303)	ANMA811 (ANM87303)	—	

# Part No. List

## Controller units

Product Name	Specification	Part No.
PV200	PhotoMOS relay output, 2-camera type	ANPV0202ADP
PV200 MC	PhotoMOS relay output, 2-camera type (Only 0.3M grey compact camera can be connected.)	ANPV0202MC
PV500V2	NPN output, 2-camera type	ANPV0502V2ADN
	PhotoMOS relay output, 2-camera type	ANPV0502V2ADP
	NPN output, 4-camera type	ANPV0504V2ADN
A230 character recognition type	PhotoMOS relay output, 4-camera type	ANPV0504V2ADP
	NPN Jpn/Eng menu, Jpn manual	ANMA230
	NPN Jpn/Eng menu, Jpn manual	ANMA210V2
A210V2 Controller	Photomos Jpn/Eng menu, Jpn manual	ANMA211V2
	NPN Eng/Jpn menu, Eng manual	ANMA212V2
	Photomos Eng/Jpn menu, no manual	ANMA213V2
	Photomos Ger/Eng menu, no manual	ANMA214V2
	Photomos Fre/Eng menu, no manual	ANMA215V2
	Photomos Spr/Eng menu, no manual	ANMA216V2
	Photomos Itl/Eng menu, no manual	ANMA217V2
	Photomos Eng/Jpn menu, Eng manual	ANMA218V2
	NPN Chi/Eng menu, Chi manual	ANMA219V2
	NPN Kor/Eng menu, Eng manual	ANMA21KV2
	A110V2 Controller	NPN Jpn/Eng menu, Jpn manual
Photomos Jpn/Eng menu, Jpn manual		ANMA111V2
NPN Eng/Jpn menu, Eng manual		ANMA112V2
Photomos Eng/Jpn menu, no manual		ANMA113V2
Photomos Ger/Eng menu, no manual		ANMA114V2
Photomos Fre/Eng menu, no manual		ANMA115V2
Photomos Spr/Eng menu, no manual		ANMA116V2
Photomos Itl/Eng menu, no manual		ANMA117V2
Photomos Eng/Jpn menu, Eng manual		ANMA118V2
NPN Chi/Eng menu, Chi manual		ANMA119V2
NPN Kor/Eng menu, Eng manual		ANMA11KV2
2D Code reading sensor PD60	Field of view: 2 × 1.6 mm <b>0.08 × 0.06 in</b> , Installation distance: 15±0.5 mm <b>0.59±0.02 in</b>	ANPD060-02
	Field of view: 4 × 3.2 mm <b>0.16 × 0.13 in</b> , Installation distance: 50±2.5 mm <b>1.97±0.10 in</b>	ANPD060-04
	Field of view: 5 × 4 mm <b>0.20 × 0.16 in</b> , Installation distance: 27±1.0 mm <b>1.06±0.04 in</b>	ANPD060-05
	Field of view: 6 × 4.8 mm <b>0.24 × 0.19 in</b> , Installation distance: 30±1.5 mm <b>1.18±0.06 in</b>	ANPD060-06
	Field of view: 10 × 8 mm <b>0.39 × 0.32 in</b> , Installation distance: 100±5.0 mm <b>3.94±0.20 in</b>	ANPD060-10
	Field of view: 12 × 10 mm <b>0.47 × 0.39 in</b> , Installation distance: 110±5.5 mm <b>4.33±0.22 in</b>	ANPD060-12
	Field of view: 15 × 12 mm <b>0.59 × 0.47 in</b> , Installation distance: 65±3.0 mm <b>2.56±0.12 in</b>	ANPD060-15
	Field of view: 20 × 16 mm <b>0.79 × 0.63 in</b> , Installation distance: 80±4.0 mm <b>3.15±0.16 in</b>	ANPD060-20
	Field of view: 25 × 20 mm <b>0.98 × 0.79 in</b> , Installation distance: 200±10 mm <b>7.78±0.39 in</b>	ANPD060-25
	Field of view: 30 × 25 mm <b>1.18 × 0.98 in</b> , Installation distance: 55±2.5 mm <b>2.17±0.10 in</b>	ANPD060-30
	Field of view: 10 × 8 mm <b>0.39 × 0.32 in</b> , Installation distance: 45±2.0 mm <b>1.77±0.08 in</b>	ANPD060S10
	Field of view: 25 × 20 mm <b>0.98 × 0.79 in</b> , Installation distance: 105±5 mm <b>4.13±0.20 in</b>	ANPD060S25
	2D Code reading sensor PD65	Field of view: 12 × 10 mm <b>0.47 × 0.39 in</b> , Installation distance: Contact type
Field of view: 25 × 20 mm <b>0.98 × 0.79 in</b> , Installation distance: Contact type		ANPD065-25

## Cameras and Camera cables ○ : Applicable model

Product Name	Specification	Part No.	PV200	PV200 MC	PV500V2	A230	A210V2/A110V2	PD60/PD65
0.3M Color camera	0.3M	ANPVC2040	○					
2M Color camera	2M	ANPVC2260	○					
0.3M Grey camera	0.3M	ANPVC1040	○		○			
0.3M Grey compact camera	0.3M	ANPVC5030	○	○				
2M Grey camera	2M	ANPVC1210	○		○			
4M Grey camera	4M	ANPVC1470	○					
Double speed random camera (C mount)	Progressive, CE product	ANM831				○	○	
Standard camera (CS mount)	with 3 m <b>9.8 ft</b> cable	ANM832				○	○	
	with 30 cm <b>1.0 ft</b> cable	ANM83203				○	○	
	with 3 m <b>9.8 ft</b> cable, CE product	ANM832CE				○	○	
Camera cable for PV series	3 m <b>9.8 ft</b>	ANPVC8103	○		○			
	5 m <b>16.4 ft</b>	ANPVC8105	○		○			
	10 m <b>32.8 ft</b>	ANPVC8110	○		○			
	Flexible 3 m <b>9.8 ft</b>	ANPVC8103R	○		○			
	Flexible 5 m <b>16.4 ft</b>	ANPVC8105R	○		○			
	Flexible 10 m <b>32.8 ft</b>	ANPVC8110R	○		○			
	For compact camera 3 m <b>9.8 ft</b>	ANPVC8203	○	○				
	For compact camera 5 m <b>16.4 ft</b>	ANPVC8205	○	○				
For compact camera 10 m <b>32.8 ft</b>	ANPVC8210	○	○					
Double-speed random camera cable	3 m <b>9.8 ft</b>	ANM84303				○	○	
	3 m <b>9.8 ft</b> CE product	ANM84303CE				○	○	
	Flexible 3 m <b>9.8 ft</b>	ANM84603				○	○	
	Flexible extension 2 m <b>6.6 ft</b> ; total 5 m <b>16.4 ft</b>	ANM84502				○	○	
	Flexible extension 7 m <b>23.0 ft</b> ; total 10 m <b>32.8 ft</b>	ANM84507				○	○	
	Flexible extension 12 m <b>39.4 ft</b> ; total 15 m <b>49.2 ft</b>	ANM84512				○	○	
Flexible extension 17 m <b>55.8 ft</b> ; total 20 m <b>65.6 ft</b>	ANM84517				○	○		

## Camera extension cables ○ : Applicable model

Product Name	Specification	Part No.	PV200	PV200 MC	PV500V2	A230	A210V2/A110V2	PD60/PD65
Camera extension cable	2 m <b>6.6 ft</b> extension: total 5 m <b>16.4 ft</b>	ANM84002A				○	○	
	7 m <b>23.0 ft</b> extension: total 10 m <b>32.8 ft</b>	ANM84007A				○	○	
	12 m <b>39.4 ft</b> extension: total 15 m <b>49.2 ft</b>	ANM84012A				○	○	
	17 m <b>55.8 ft</b> extension: total 20 m <b>65.6 ft</b>	ANM84017A				○	○	
	2 m <b>6.6 ft</b> extension: total 5 m <b>16.4 ft</b> , CE product	ANM84002ACE				○	○	
	7 m <b>23.0 ft</b> extension: total 10 m <b>32.8 ft</b> , CE product	ANM84007ACE				○	○	
	12 m <b>39.4 ft</b> extension: total 15 m <b>49.2 ft</b> , CE product	ANM84012ACE				○	○	
	17 m <b>55.8 ft</b> extension: total 20 m <b>65.6 ft</b> , CE product	ANM84017ACE				○	○	

## Keypads ○ : Applicable model

Product Name	Specification	Part No.	PV200	PV200 MC	PV500V2	A230	A210V2/A110V2	PD60/PD65
Keypad for A series	with 2 m <b>6.6 ft</b> cable	ANM85202				○	○	
	with 3 m <b>9.8 ft</b> cable	ANM85203				○	○	
	with 5 m <b>16.4 ft</b> cable	ANM85205				○	○	
	with 10 m <b>32.8 ft</b> cable	ANM85210				○	○	
	with 2 m <b>6.6 ft</b> cable, CE product	ANM85202CE				○	○	
	with 3 m <b>9.8 ft</b> cable, CE product	ANM85203CE				○	○	
	with 5 m <b>16.4 ft</b> cable, CE product	ANM85205CE				○	○	
	with 10 m <b>32.8 ft</b> cable, CE product	ANM85210CE				○	○	
	Keypad for PV series	3 m <b>9.8 ft</b> , CE product	ANPVP03	○	○	○		
10 m <b>32.8 ft</b> , CE product		ANPVP10	○	○	○			

## Lens ○ : Applicable model

Product Name	Specification	Part No.	PV200	PV200 MC	PV500V2	A230	A210V2/A110V2	PD60/PD65
For 0.3M camera	f=6 C mount lens with lock	ANB842NL	○	○	○	○	○	
	f=8.5 C mount lens with lock	ANB843L	○	○	○	○	○	
	f=16 C mount compact lens with lock	ANB845NL	○	○	○	○	○	
	f=25 C mount compact lens with lock	ANB846NL	○	○	○	○	○	
	f=50 C mount lens with lock	ANB847L	○	○	○	○	○	
	f=16 C mount ultra compact lens with lock	ANM88161	○	○	○	○	○	
	f=25 C mount ultra compact lens with lock	ANM88251	○	○	○	○	○	
	f=50 C mount compact lens with lock	ANM88501	○	○	○	○	○	
For 2-megapixel camera	f=16 C mount lens with lock	ANPVL162	○		○			
	f=25 C mount lens with lock	ANPVL252	○		○			
	f=50 C mount lens with lock	ANPVL502	○		○			

## Adapter rings ○ : Applicable model

Product Name	Specification	Part No.	PV200	PV200 MC	PV500V2	A230	A210V2/A110V2	PD60/PD65
For C mount/CS mount lens	Ring set (40/20/10/5/1/0.5 mm <b>1.58/0.79/0.39/0.20/0.04/0.02 in</b> , each 1 pc.)	ANB848	○	○	○	○	○	
	5 mm <b>0.20 in</b> adapter ring, 1pc.	ANB84805	○	○	○	○	○	

## Monitors and Monitor cables ○ : Applicable model

Product Name	Specification	Part No.	PV200	PV200 MC	PV500V2	A230	A210V2/A110V2	PD60/PD65
XGA monitor	24 V DC, 10.4 inches	ANPVM11021	○	○	○			
NTSC monitor	24 V DC, 5.7 inches	ANMA811				○	○	
For VGA monitor and XGA monitor	Monitor cable: Length: 3 m <b>9.8 ft</b> , BNC-Pin (RCA)	ANM87303				○	○	
	Monitor cable: 3 m <b>9.8 ft</b>	ANMX83313	○	○	○			
	Monitor cable: 5 m <b>16.4 ft</b>	ANMX83315	○	○	○			

## Others ○ : Applicable model

Product Name	Specification	Part No.	PV200	PV200 MC	PV500V2	A230	A210V2/A110V2	PD60/PD65
Attachment bracket	4 attachment bracket for 4M grey camera For mounting PD60	ANPVM005 ANE8870	○					○
I/O terminal block	For input: 1 piece, For output: 1 piece	ANMA8001				○	○	
Options (repair parts)	Set with PD65 guide pipe, packing, and stop screws	ANPD068-G1						○
	Set with PD65 guide pipe (short pipe type), packing, and stop screws	ANPD068-G2						○
	Power supply I/O cable (2,700 mm <b>106.30 in</b> ) for PD 60	ANPD068-K1						○
	Set with PD60 front panel, packing, and stop screws	ANPD068-P1						○
Extension cables	Set with PD60 front panel (narrow view type), packing, and stop screws	ANPD068-P2						○
	3 m <b>9.8 ft</b>	ANPD068-03						○
	5 m <b>16.4 ft</b>	ANPD068-05						○
	10 m <b>32.8 ft</b>	ANPD068-10						○
RS232C communication cable	For PLC (discrete-wire cable) connection, 2 m <b>6.6 ft</b>	AIP81842			○			
	For PC (D-SUB : 9 pin) connection, 3 m <b>9.8 ft</b>	AFB85853			○			
	For PLC (discrete-wire cable) connection, 3 m <b>9.8 ft</b>	ANM81303				○	○	
	For PC (D-SUB : 9 pin) connection, 3 m <b>9.8 ft</b>	ANM81103				○	○	



# Specifications

## Camera specifications

Item	Specifications					
Type/Part No.	4M grey / ANPVC1470	2M grey / ANPVC1210	0.3M grey / ANPVC1040	0.3M grey compact / ANPVC5030	2M color/ANPVC2260	0.3M color/ANPVC2040
Capture element	Inter line method 2/3-inch CCD fixed image element	Inter line method 1/1.8-inch CCD fixed image element	Inter line method 1/3-inch CCD fixed image element	Inter line method 1/3-inch CMOS fixed image element	Inter line method 1/1.8-inch CCD fixed image element	Inter line method 1/3-inch CCD fixed image element
Pixels	2,048 horizontal x 2,048 vertical pixels	1,600 horizontal x 1,200 vertical pixels	640 horizontal x 480 vertical pixels	640 horizontal x 480 vertical pixels	1,600 horizontal x 1,200 vertical pixels	640 horizontal x 480 vertical pixels
	Pixel size: 3.45 μm x 3.45 μm (Square pixels)	Pixel size: 4.4 μm x 4.4 μm (Square pixels)	Pixel size: 7.4 μm x 7.4 μm (Square pixels)	Pixel size: 6.0 μm x 6.0 μm (Square pixels)	Pixel size: 4.4 μm x 4.4 μm (Square pixels)	Pixel size: 7.4 μm x 7.4 μm (Square pixels)
Frame rate	16 frames/sec max.	30 frames/sec max.	120 frames/sec max.	90 frames/sec max.	30 frames/sec max.	120 frames/sec max.
Lens mount	C mount			NF mount *2	C mount	
Ambient temperature during use *1	0 to +40 °C +32 to +104 °F	0 to +40 °C +32 to +104 °F	0 to +45 °C +32 to +113 °F	0 to +40 °C +32 to +104 °F	0 to +40 °C +32 to +104 °F	0 to +45 °C +32 to +113 °F
Ambient humidity during use	35 to 85% RH (at 25 °C 77 °F, no freezing or condensation)					
Vibration resistance	10 to 55 Hz, 1 sweep/min, double amplitude of 1 mm 0.04 in, 30 minutes each in the X, Y, and Z directions			10 to 200 Hz, 1 sweep/10 min, 30 minutes each in the 3 directions	10 to 55 Hz, 1 sweep/min, double amplitude of 1 mm 0.04 in, 30 minutes each in the X, Y, and Z directions	
Shock resistance	490.3 m/s <sup>2</sup> , 1 time each in the X, Y and Z directions		700 m/s <sup>2</sup> , 3 times each in the X, Y and Z directions	700 m/s <sup>2</sup> , 1 time each in the X, Y and Z directions	700 m/s <sup>2</sup> , 3 times each in the X, Y and Z directions	
Weight (Excluding the lens)	125 g approx.	65 g approx.	65 g approx.	30 g approx.	65 g approx.	65 g approx.

\*1 No freezing or condensation \*2 Comes with C mount adapter.

## Visual Fields

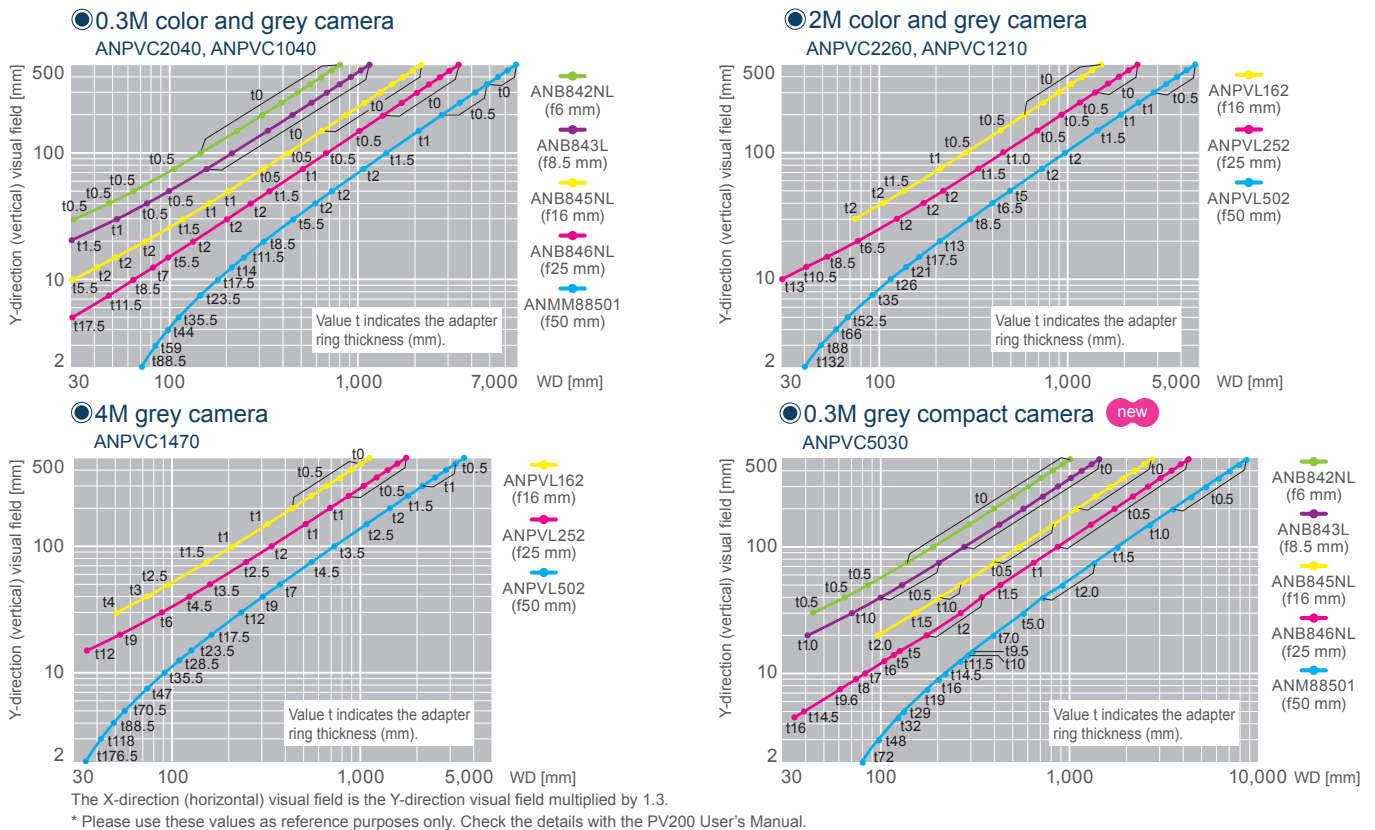

Please contact .....

## Panasonic Electric Works SUNX Co., Ltd.

2431-1 Ushiyama-cho, Kasugai-shi, Aichi, 486-0901, Japan  
 ■ Telephone: +81-568-33-7211 ■ Facsimile: +81-568-33-2631  
 Global Sales & Marketing Division  
 ■ Telephone: +81-568-33-7861 ■ Facsimile: +81-568-33-8591  
[panasonic-electric-works.net/sunx](http://panasonic-electric-works.net/sunx)



All Rights Reserved ©Panasonic Electric Works SUNX Co., Ltd. 2011

**Note that some cameras and camera cables for PV200 can not be used in combination.**

## Camera cable

4M grey camera (**ANPVC1470**) can not be used in combination with following 4 types camera cables.

Camera cables for PV200   5 m **16.4 ft** type (**ANPVC8105**)  
10 m **32.8 ft** type (**ANPVC8110**)  
Flexible camera cables   5 m **16.4 ft** type (**ANPVC8105R**)  
10 m **32.8 ft** type (**ANPVC8110R**)

## P.14 Product list



5 m type and 10 m type can not be used in combination with the 4M grey camera (**ANPVC1470**).

## P.18 Part No. list

Cameras and Camera cables ○: Applicable model

Product Name	Specification	Part No.	PV200	PV200 MC	PV500V2	A230	A210V2/A110V2	PD60/PD65
0.3M Color camera	0.3M	ANPVC2040	○					
2M Color camera	2M	ANPVC2260	○					
0.3M Grey camera	0.3M	ANPVC1040	○		○			
0.3M Grey compact camera	0.3M	ANPVC5030	○	○				
2M Grey camera	2M	ANPVC1210	○		○			
4M Grey camera	4M	ANPVC1470	○					
Double speed random camera (C mount)	Progressive, CE product	ANM831				○	○	
Standard camera (CS mount)	with 3 m <b>9.8 ft</b> cable	ANM832				○	○	
	with 30 cm <b>1.0 ft</b> cable	ANM83203				○	○	
	with 3 m <b>9.8 ft</b> cable, CE product	ANM832CE				○	○	
Camera cable for PV series	3 m <b>9.8 ft</b>	ANPVC8103	○		○			
	5 m <b>16.4 ft</b>	ANPVC8105	○		○			
	10 m <b>32.8 ft</b>	ANPVC8110	○		○			
	Flexible 3 m <b>9.8 ft</b>	ANPVC8103R	○		○			
	Flexible 5 m <b>16.4 ft</b>	ANPVC8105R	○		○			
	Flexible 10 m <b>32.8 ft</b>	ANPVC8110R	○		○			
	For compact camera 3 m <b>9.8 ft</b>	ANPVC8203	○	○				
	For compact camera 5 m <b>16.4 ft</b>	ANPVC8205	○	○				
	For compact camera 10 m <b>32.8 ft</b>	ANPVC8210	○	○				
Double-speed random camera cable	3 m <b>9.8 ft</b>	ANM84303				○	○	
	3 m <b>9.8 ft</b> CE product	ANM84303CE				○	○	
	Flexible 3 m <b>9.8 ft</b>	ANM84603				○	○	
	Flexible extension 2 m <b>6.6 ft</b> : total 5 m <b>16.4 ft</b>	ANM84502				○	○	
	Flexible extension 7 m <b>23.0 ft</b> : total 10 m <b>32.8 ft</b>	ANM84507				○	○	
	Flexible extension 12 m <b>39.4 ft</b> : total 15 m <b>49.2 ft</b>	ANM84512				○	○	
	Flexible extension 17 m <b>55.8 ft</b> : total 20 m <b>65.6 ft</b>	ANM84517				○	○	

5 m type (**ANPVC8105**), 10 m type (**ANPVC8110**), Flexible 5 m type (**ANPVC8105R**) and Flexible 10 m type (**ANPVC8110R**) of camera cables for PV series can not be used in combination with the 4M grey camera (**ANPVC1470**).

## P.19 Part No. list

PV200MC can not be used in combination with **ANB843L**, **ANM88161** and **ANM88251**.

Lens ○: Applicable model

Product Name	Specification	Part No.	PV200	PV200 MC	PV500V2	A230	A210V2/A110V2	PD60/PD65
For 0.3M camera	f=6 C mount lens with lock	ANB842NL	○	○	○	○	○	○
	f=8.5 C mount lens with lock	ANB843L	○	○	○	○	○	
	f=16 C mount compact lens with lock	ANB845NL	○	○	○	○	○	
	f=25 C mount compact lens with lock	ANB846NL	○	○	○	○	○	
	f=50 C mount lens with lock	ANB847L	○	○	○	○	○	
	f=16 C mount ultra compact lens with lock	ANM88161	○	○	○	○	○	
	f=25 C mount ultra compact lens with lock	ANM88251	○	○	○	○	○	
	f=50 C mount compact lens with lock	ANM88501	○	○	○	○	○	
For 2-megapixel camera	f=16 C mount lens with lock	ANPVL162	○		○			
	f=25 C mount lens with lock	ANPVL252	○		○			
	f=50 C mount lens with lock	ANPVL502	○		○			

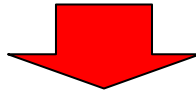

Lens ○: Applicable model

Product Name	Specification	Part No.	PV200	PV200 MC	PV500V2	A230	A210V2/A110V2	PD60/PD65
For 0.3M camera	f=6 C mount lens with lock	ANB842NL	○	○	○	○	○	○
	f=8.5 C mount lens with lock	ANB843L	○	○	○	○	○	
	f=16 C mount compact lens with lock	ANB845NL	○	○	○	○	○	
	f=25 C mount compact lens with lock	ANB846NL	○	○	○	○	○	
	f=50 C mount lens with lock	ANB847L	○	○	○	○	○	
	f=16 C mount ultra compact lens with lock	ANM88161	○	○	○	○	○	
	f=25 C mount ultra compact lens with lock	ANM88251	○	○	○	○	○	
	f=50 C mount compact lens with lock	ANM88501	○	○	○	○	○	
For 2-megapixel camera	f=16 C mount lens with lock	ANPVL162	○		○			
	f=25 C mount lens with lock	ANPVL252	○		○			
	f=50 C mount lens with lock	ANPVL502	○		○			

## P.20 Visual Fields

**ANB843L** (Purple line) in graph of the 0.3M grey compact camera is correct. **ANB843L** can not be used in combination with the 0.3M grey compact camera.

