



Chipsmall Limited consists of a professional team with an average of over 10 year of expertise in the distribution of electronic components. Based in Hongkong, we have already established firm and mutual-benefit business relationships with customers from,Europe,America and south Asia,supplying obsolete and hard-to-find components to meet their specific needs.

With the principle of “Quality Parts,Customers Priority,Honest Operation,and Considerate Service”,our business mainly focus on the distribution of electronic components. Line cards we deal with include Microchip,ALPS,ROHM,Xilinx,Pulse,ON,Everlight and Freescale. Main products comprise IC,Modules,Potentiometer,IC Socket,Relay,Connector.Our parts cover such applications as commercial,industrial, and automotives areas.

We are looking forward to setting up business relationship with you and hope to provide you with the best service and solution. Let us make a better world for our industry!



Contact us

Tel: +86-755-8981 8866 Fax: +86-755-8427 6832

Email & Skype: info@chipsmall.com Web: www.chipsmall.com

Address: A1208, Overseas Decoration Building, #122 Zhenhua RD., Futian, Shenzhen, China



ANT-DB1-RAF-xxx

Data Sheet

Product Description

The RAF is a compact, cosmetically attractive, dual-band, $\frac{1}{2}$ -wave antenna covering the popular 2.45 and emerging 5GHz bands. The antenna features a tilt and swivel joint which allows it to be oriented at straight or right angle to the product or conveniently folded for storage and shipment. It attaches using an SMA or Part 15 compliant RP-SMA connector.

Features

- Tilts and rotates
- Dual-band
- Excellent performance
- Omni-directional pattern
- Very low VSWR
- Rugged & damage-resistant
- Standard SMA or Part 15 compliant RP-SMA connector

Electrical Specifications

Recom. Freq. Range:	Band 1: 2.40–2.483GHz Band 2: 5.15–5.825GHz
Peak Gain:	Band 1: 2.5dBi Band 2: 4.6dBi
Wavelength:	$\frac{1}{2}$ -wave
VSWR:	≤ 1.9 typical at center
Impedance:	50-ohms
Connection:	RP-SMA or SMA
Oper. Temp. Range:	-40°C to $+80^{\circ}\text{C}$

Electrical specifications and plots measured on 10.16 cm x 10.16 cm (4.00" x 4.00") reference ground plane

Ordering Information

ANT-DB1-RAF-RPS (with RP-SMA connector)

ANT-DB1-RAF-SMA (with SMA connector)

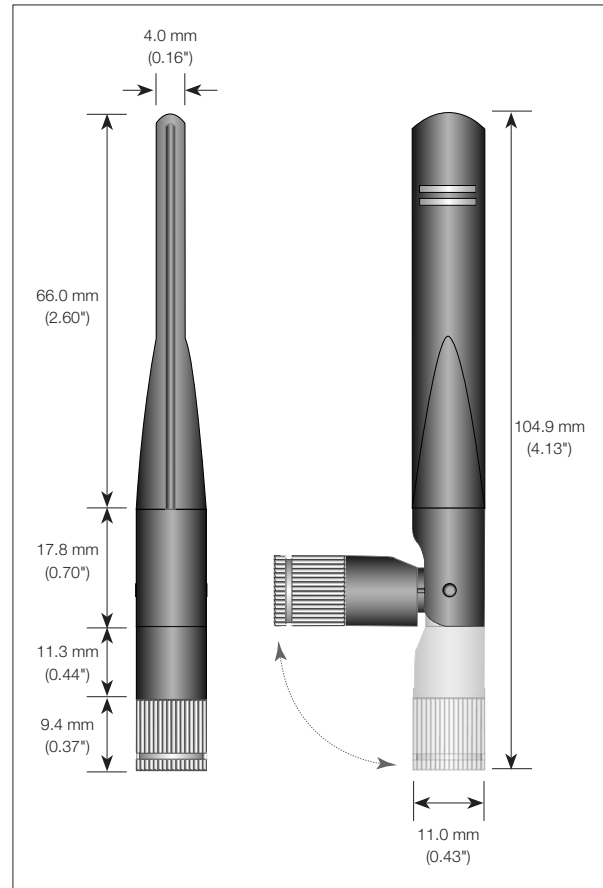

VSWR Graph

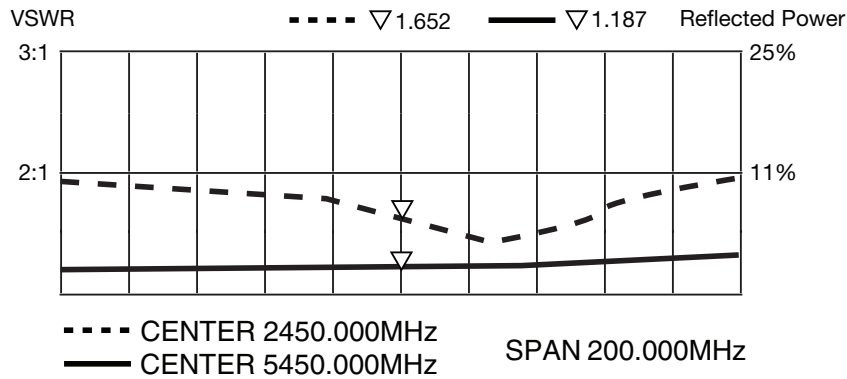

What is VSWR?

The Voltage Standing Wave Ratio (VSWR) is a measurement of how well an antenna is matched to a source impedance, typically 50-ohms. It is calculated by measuring the voltage wave that is headed toward the load versus the voltage wave that is reflected back from the load. A perfect match will have a VSWR of 1:1. The higher the first number, the worse the match, and the more inefficient the system. Since a perfect match cannot ever be obtained, some benchmark for performance needs to be set. In the case of antenna VSWR, this is usually 2:1. At this point, 88.9% of the energy sent to the antenna by the transmitter is radiated into free space and 11.1% is either reflected back into the source or lost as heat on the structure of the antenna. In the other direction, 88.9% of the energy recovered by the antenna is transferred into the receiver. As a side note, since the “:1” is always implied, many data sheets will remove it and just display the first number.

How to Read a VSWR Graph

VSWR is usually displayed graphically versus frequency. The lowest point on the graph is the antenna’s operational center frequency. In most cases, this will be different than the designed center frequency due to fabrication tolerances. The VSWR at that point denotes how close to 50-ohms the antenna gets. Linx specifies the recommended bandwidth as the range where the typical antenna VSWR is less than 2:1.