



Chipsmall Limited consists of a professional team with an average of over 10 year of expertise in the distribution of electronic components. Based in Hongkong, we have already established firm and mutual-benefit business relationships with customers from,Europe,America and south Asia,supplying obsolete and hard-to-find components to meet their specific needs.

With the principle of “Quality Parts,Customers Priority,Honest Operation,and Considerate Service”,our business mainly focus on the distribution of electronic components. Line cards we deal with include Microchip,ALPS,ROHM,Xilinx,Pulse,ON,Everlight and Freescale. Main products comprise IC,Modules,Potentiometer,IC Socket,Relay,Connector.Our parts cover such applications as commercial,industrial, and automotives areas.

We are looking forward to setting up business relationship with you and hope to provide you with the best service and solution. Let us make a better world for our industry!



Contact us

Tel: +86-755-8981 8866 Fax: +86-755-8427 6832

Email & Skype: info@chipsmall.com Web: www.chipsmall.com

Address: A1208, Overseas Decoration Building, #122 Zhenhua RD., Futian, Shenzhen, China



DATA SHEET

WIRELESS COMPONENTS

PCB type antenna
ANTX100P001BWPEN3
850/900/1800/1900/2100 MHz



FEATURES & BENEFITS

- The smallest PCB antenna in the market
- Miniature design allows users to save required space
- Double-side adhesive tape makes it easy to instal in device
- Ranges of types of connector and cable provide a flexible design options
- Halogen free and RoHS compliant

APPLICATIONS

- Tablet / Desktop PC
- Internet TV / STB / Game console / DS
- WiFi network devices (IEEE 802.11 b/g/n)
- Bluetooth / ZigBee devices
- Car Infotainment
- Smart meter
- Smart home
- POS terminal
- Wireless Industrial Control

ORDERING INFORMATION-GLOBAL PART NUMBER, PHYCOMP

CTC & I2NC

All part numbers are identified by the series, packing type, material, size, antenna type, working frequency and packing quantity.

YAGEO BRAND ordering code

GLOBAL PART NUMBER (PREFERRED)

ANT X100 P 001 B WPEN 3

(1) (2) (3) (4) (5) (6) (7)

(1) FAMILY

ANT = Antenna products

(2) CONNECTOR & CABLE LENGTH (MM)

X = I-PEX
100 = 100mm

(3) ANTENNA TYPE

P=PCB

(4) SERIAL NUMBER

001 = SERIAL NUMBER 001

(5) PACKAGE TYPE

B = Bulk

(6) WORKING FREQUENCY

WPEN = 850/900/1800/1900/2100 MHz

(7) CABLE TYPE

3 = 1.13mm diameter Mini-Coaxial Cable

SPECIFICATIONS

Table 1

DESCRIPTION	VALUE
Working Frequency	850/900/1800/1900/2100MHz
VSWR	3.0:1 max
Peak Gain	850MHz /4.2dbi(Typ) 900MHz/5.1dbi(Typ) 1800MHz /3.9dbi(Typ) 1900MHz /5.0dbi(Typ) 2100MHz /4.5dbi(Typ)
Polarization	Linear
Radiation Pattern	Omni-directional
Impedance	50 Ω Nominal
Operating Temperature	- 40 °C to 85 °C
Maximum Power	1 W
PCB Dimension	50mm x 20mm x 0.95mm
Radio Connector	I-PEX (20278-112R-13)
Cable Diameter / Length / Color	1.13mm / 100mm / Black
Mounting	Adhesive Tape (HF-DS)

DIMENSIONS

Table 2 Mechanical Dimension

DIMENSION	VALUE
L (mm)	100 ± 3.00
W (mm)	50 ± 0.30
H (mm)	20 ± 0.30
T (mm)	0.95 ± 0.15
A (mm)	2.30 Max
B (mm)	1.80 ± 1.00

OUTLINES

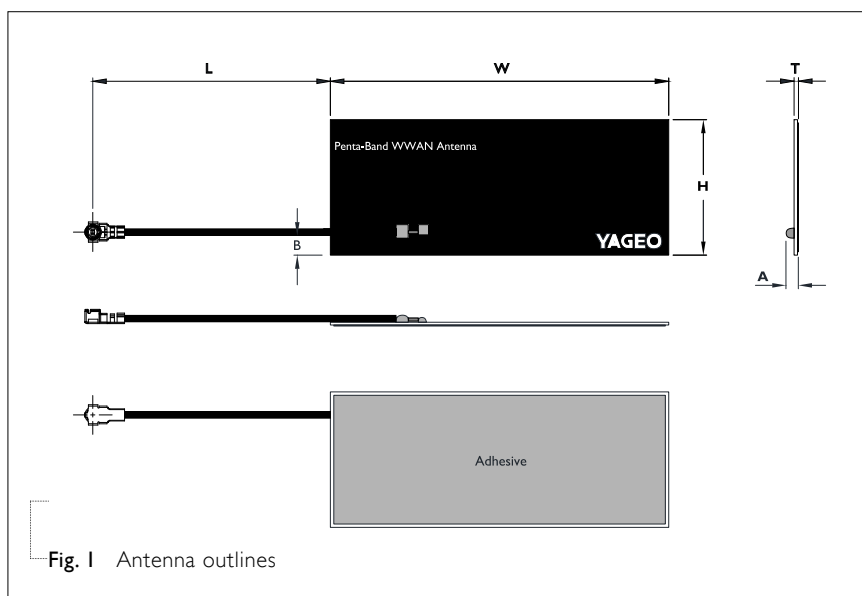
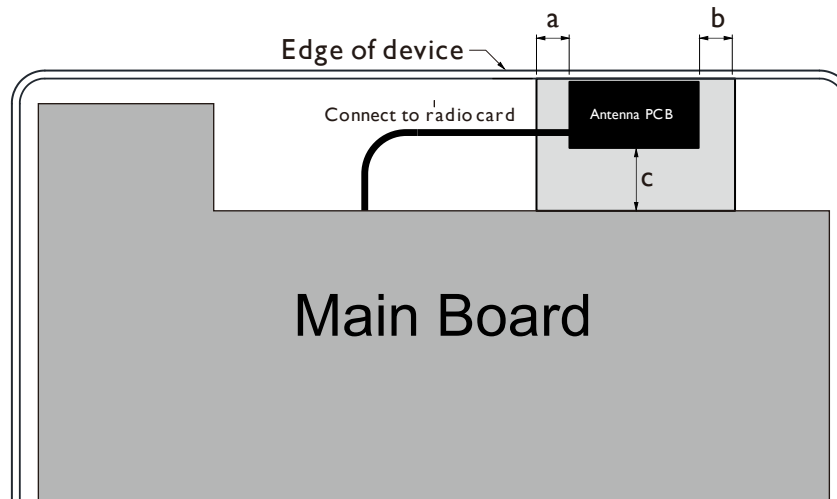
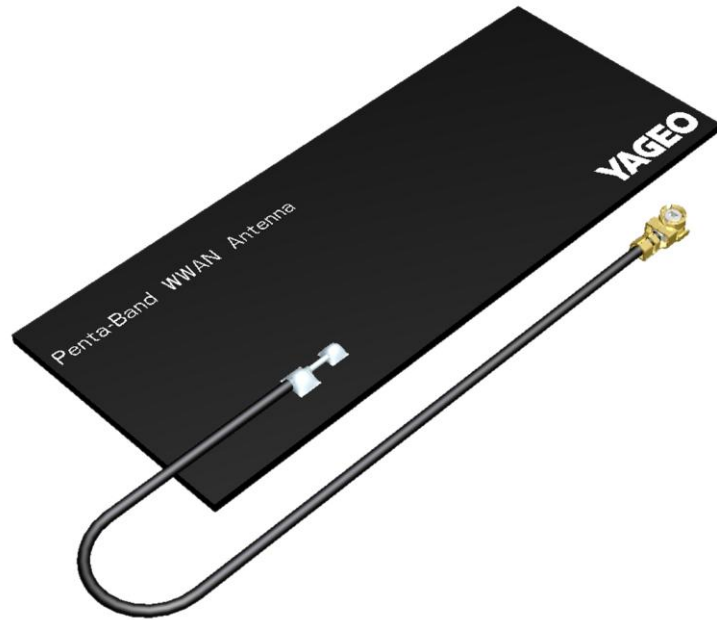

Fig. 1 Antenna outlines

APPLICATION INSTRUCTION



Antenna element should be placed at the edge of device, has minimum clearance from metallic object:

- A: 5 mm Min
- B: 5 mm Min
- C: 10 mm Min

Fig. 2 Application Instruction

RETURN LOSS & VSWR

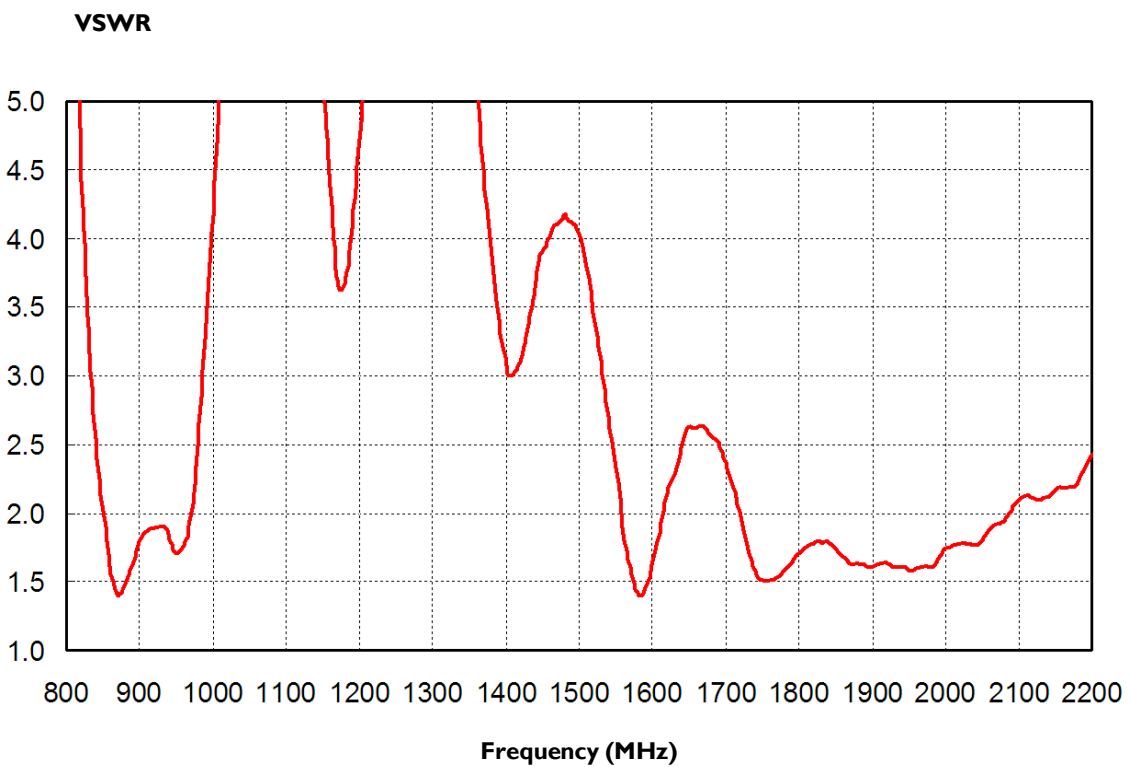
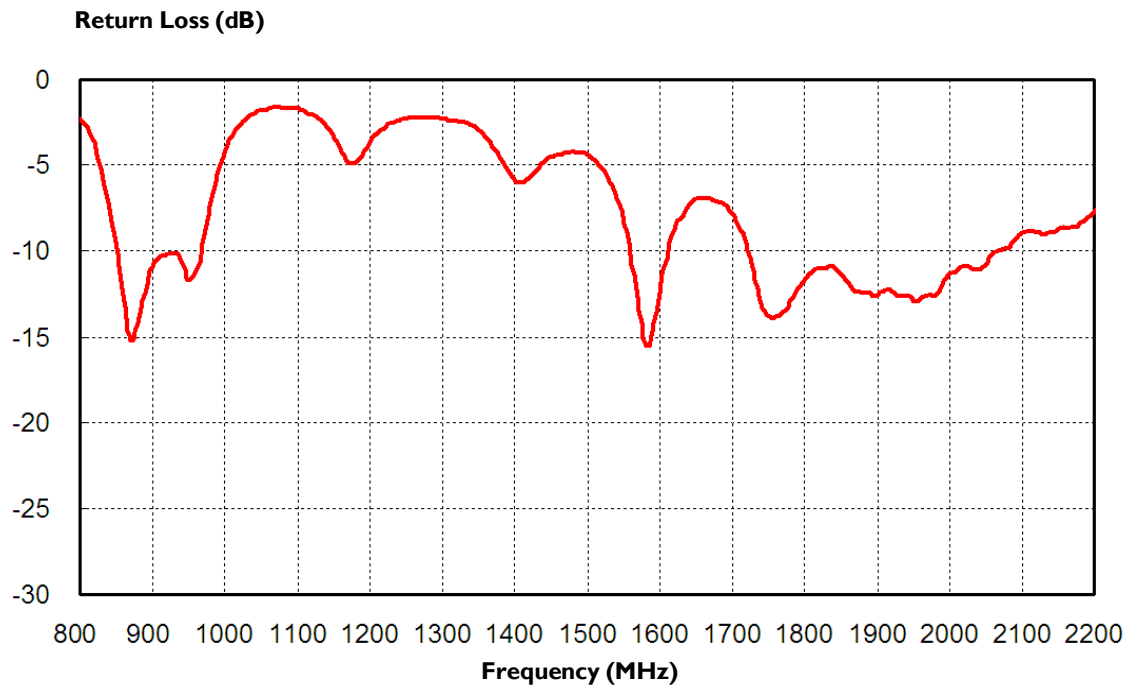

Fig. 3 Return loss & VSWR Measurement

ANTENNA GAIN & EFFICIENCY

Table 3

FREQUENCY (MHz)	AVERAGE GAIN (dBi)	EFFICIENCY (%)	PEAK GAIN (dBi)
850	-2.2	60	4.2
900	-1.7	68	5.1
1800	-2.6	55	3.9
1900	-1.2	76	5.0
2100	-2.1	62	4.5

ANTENNA RADIATION PATTERNS

Scale: 5 dBi / div Max : 5 dBi Min : -25 dBi

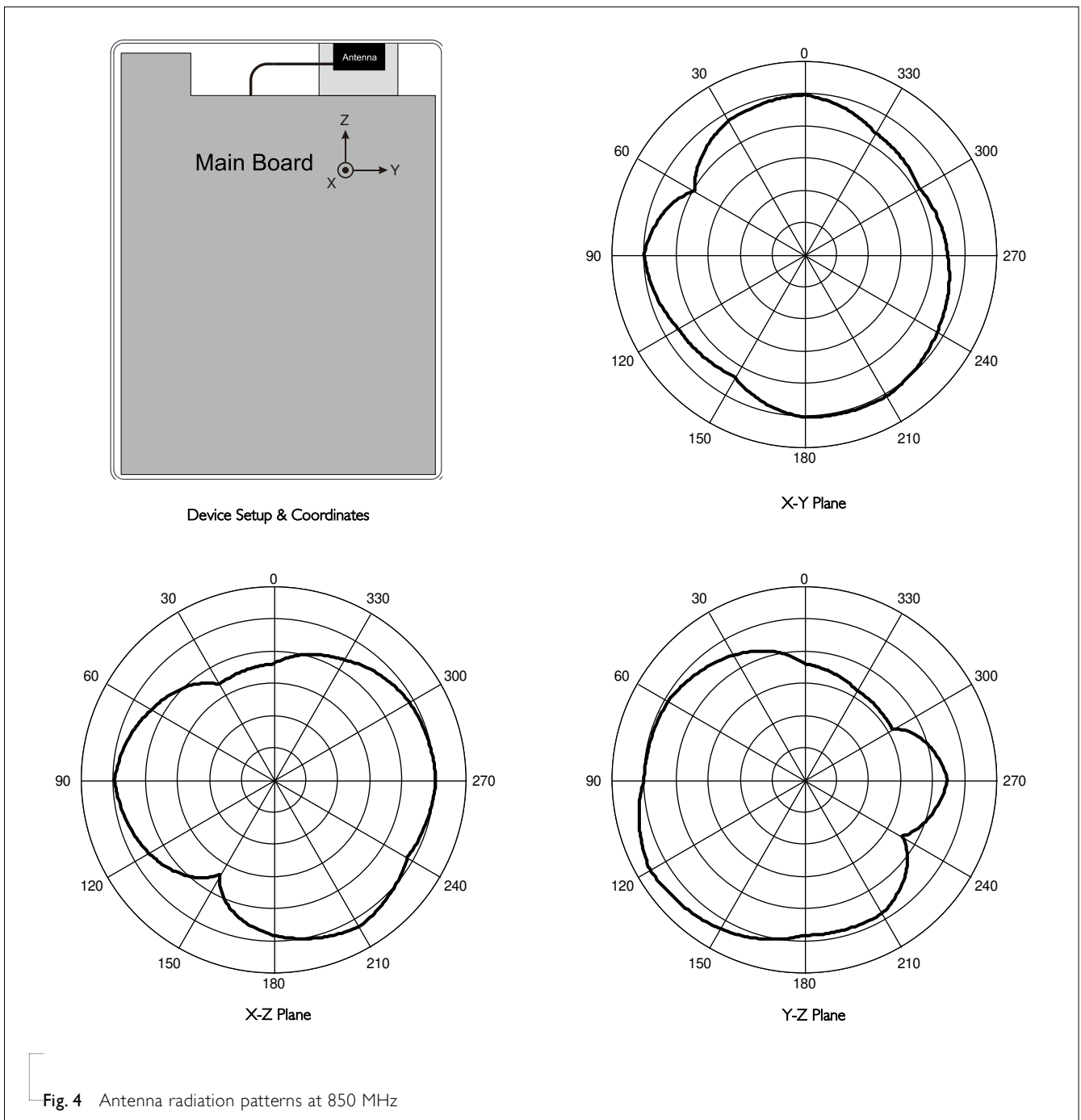

Fig. 4 Antenna radiation patterns at 850 MHz

ANTENNA GAIN & EFFICIENCY

Table 4

FREQUENCY (MHz)	AVERAGE GAIN (dBi)	EFFICIENCY (%)	PEAK GAIN (dBi)
850	-2.2	60	4.2
900	-1.7	68	5.1
1800	-2.6	55	3.9
1900	-1.2	76	5.0
2100	-2.1	62	4.5

ANTENNA RADIATION PATTERNS

Scale: 5 dBi / div Max : 5 dBi Min : -25 dBi

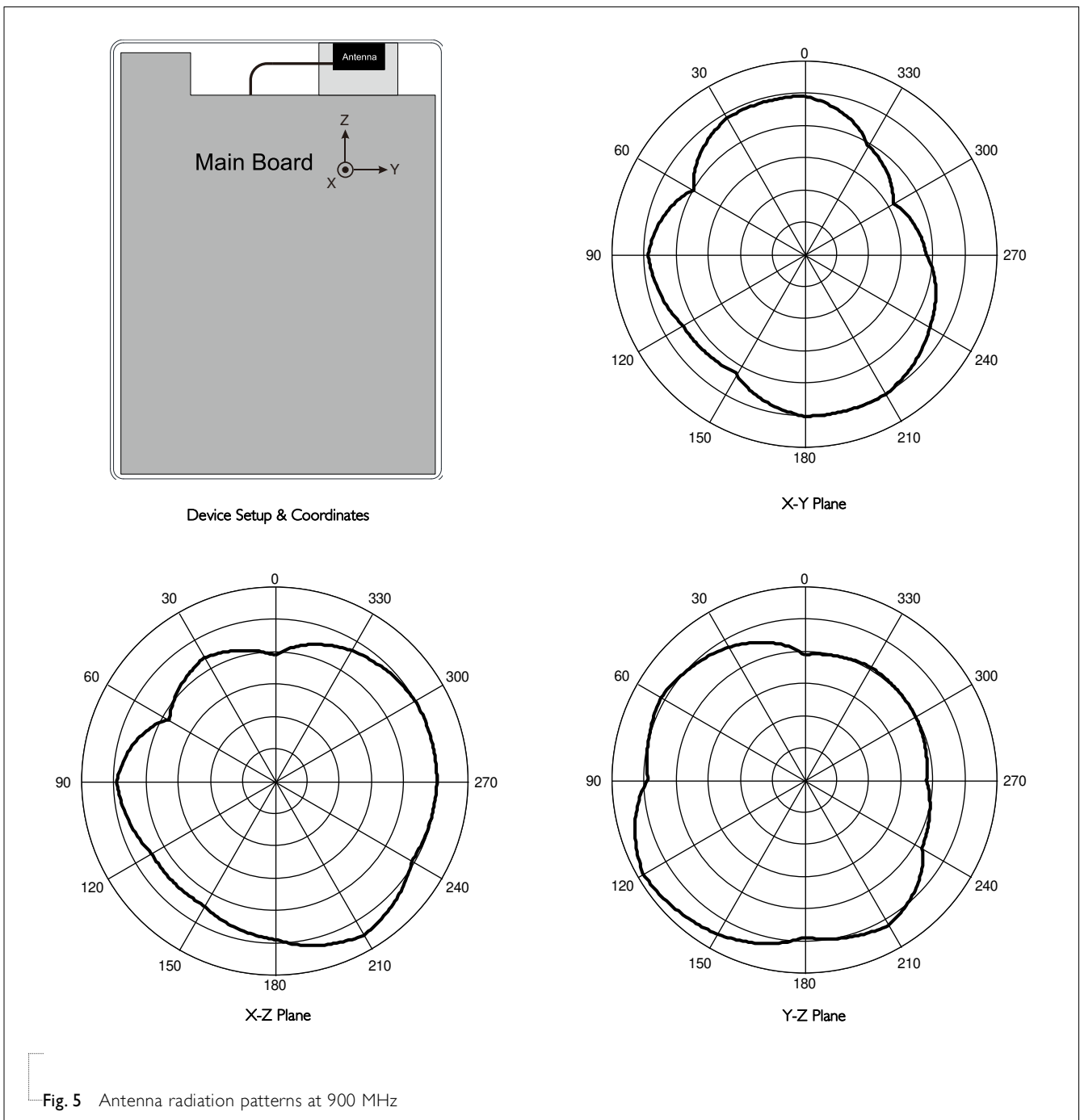

ANTENNA GAIN & EFFICIENCY

Table 4

FREQUENCY (MHz)	AVERAGE GAIN (dBi)	EFFICIENCY (%)	PEAK GAIN (dBi)
850	-2.2	60	4.2
900	-1.7	68	5.1
1800	-2.6	55	3.9
1900	-1.2	76	5.0
2100	-2.1	62	4.5

ANTENNA RADIATION PATTERNS

Scale: 5 dBi / div Max : 5 dBi Min : -25 dBi

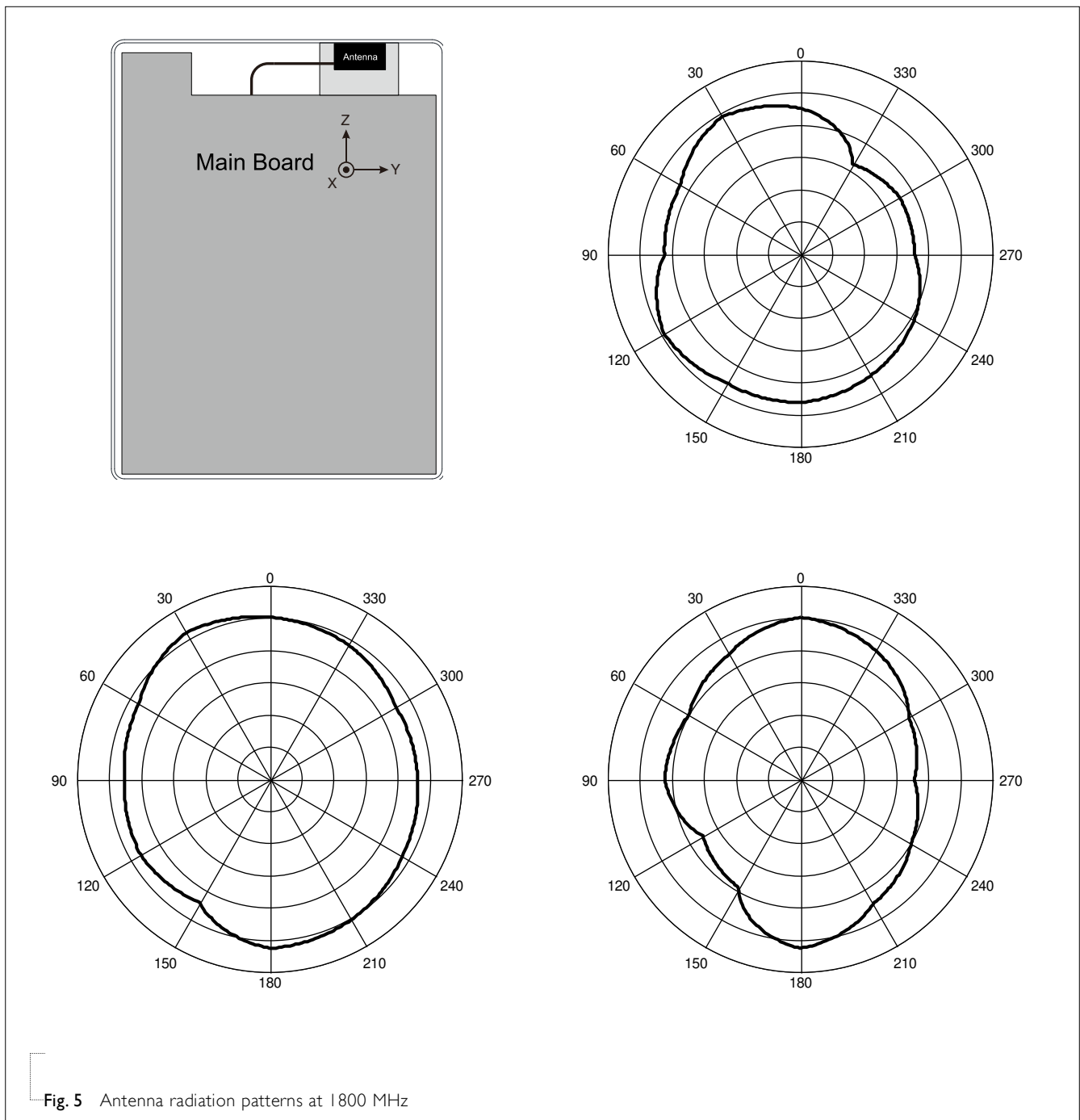

ANTENNA GAIN & EFFICIENCY

Table 4

FREQUENCY (MHz)	AVERAGE GAIN (dBi)	EFFICIENCY (%)	PEAK GAIN (dBi)
850	-2.2	60	4.2
900	-1.7	68	5.1
1800	-2.6	55	3.9
1900	-1.2	76	5.0
2100	-2.1	62	4.5

ANTENNA RADIATION PATTERNS

Scale: 5 dBi / div Max : 5 dBi Min : -25 dBi

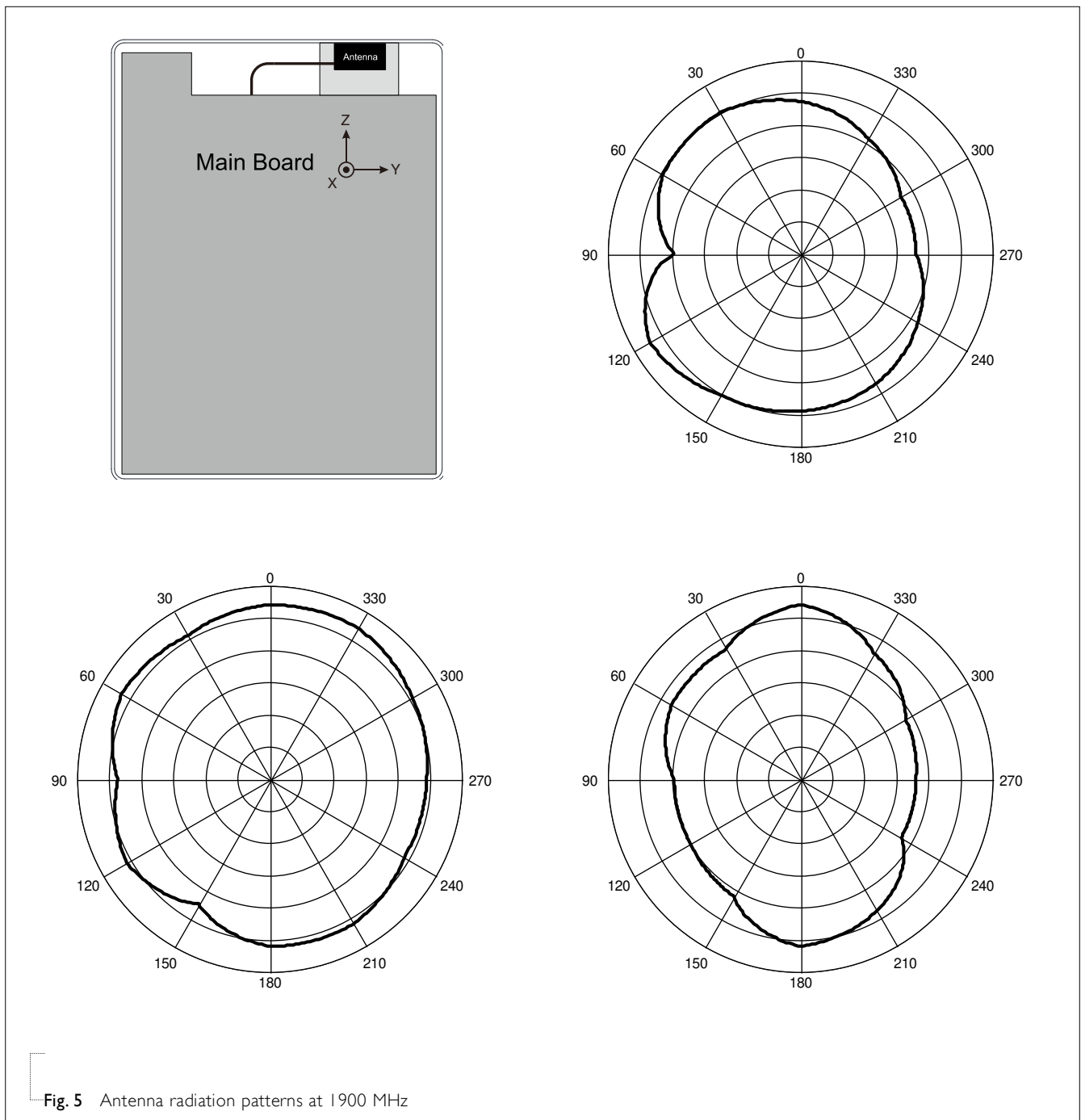

ANTENNA GAIN & EFFICIENCY

Table 4

FREQUENCY (MHz)	AVERAGE GAIN (dBi)	EFFICIENCY (%)	PEAK GAIN (dBi)
850	-2.2	60	4.2
900	-1.7	68	5.1
1800	-2.6	55	3.9
1900	-1.2	76	5.0
2100	-2.1	62	4.5

ANTENNA RADIATION PATTERNS

Scale: 5 dBi / div Max : 5 dBi Min : -25 dBi

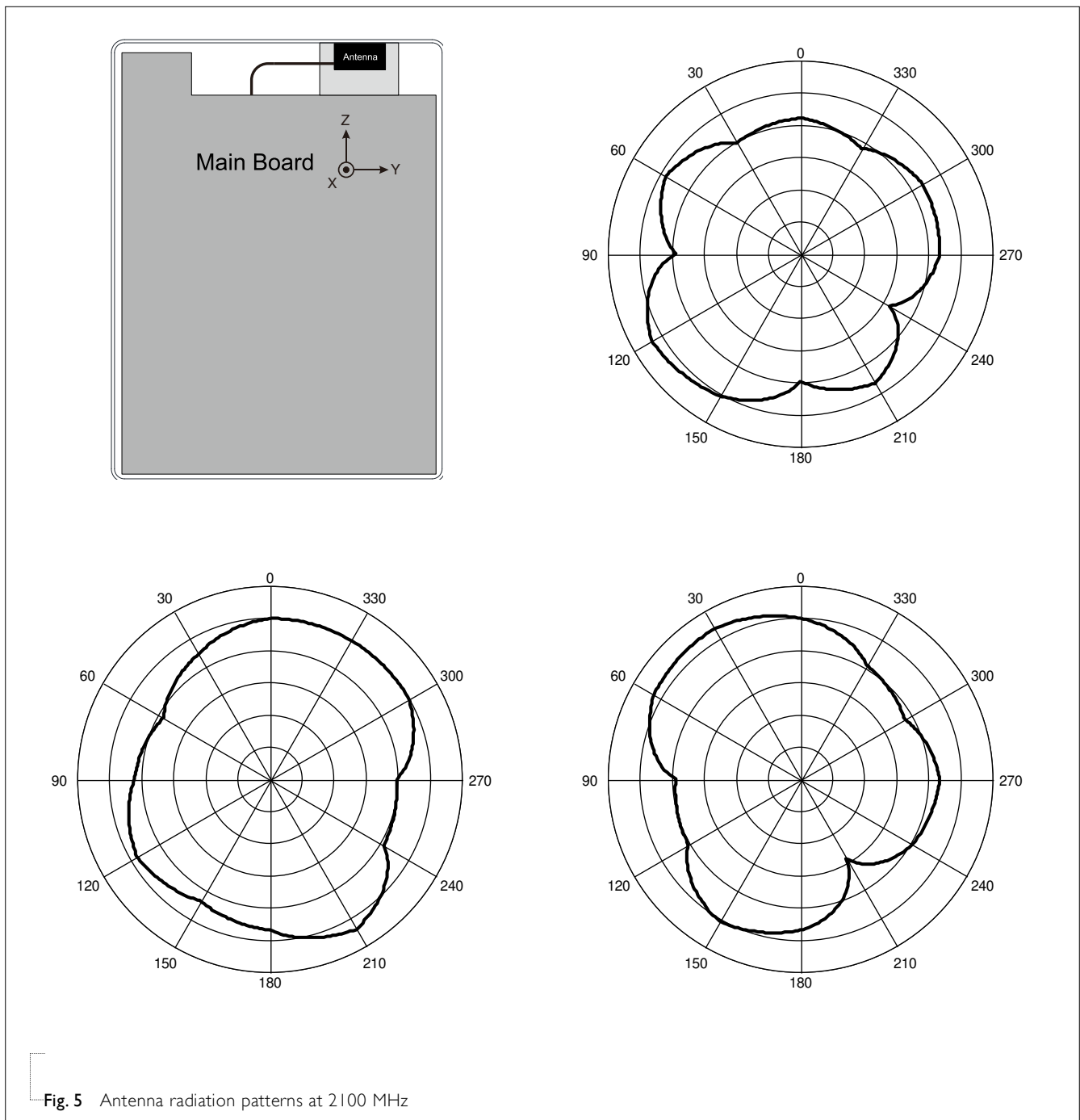

REVISION HISTORY

REVISION	DATE	CHANGE NOTIFICATION	DESCRIPTION
Version 0	Jun. 10, 2014	-	- New data sheet for PCB type antenna, 850/900/1800/1900/2100 MHz