



Chipsmall Limited consists of a professional team with an average of over 10 year of expertise in the distribution of electronic components. Based in Hongkong, we have already established firm and mutual-benefit business relationships with customers from,Europe,America and south Asia,supplying obsolete and hard-to-find components to meet their specific needs.

With the principle of “Quality Parts,Customers Priority,Honest Operation,and Considerate Service”,our business mainly focus on the distribution of electronic components. Line cards we deal with include Microchip,ALPS,ROHM,Xilinx,Pulse,ON,Everlight and Freescale. Main products comprise IC,Modules,Potentiometer,IC Socket,Relay,Connector.Our parts cover such applications as commercial,industrial, and automotives areas.

We are looking forward to setting up business relationship with you and hope to provide you with the best service and solution. Let us make a better world for our industry!



Contact us

Tel: +86-755-8981 8866 Fax: +86-755-8427 6832

Email & Skype: info@chipsmall.com Web: www.chipsmall.com

Address: A1208, Overseas Decoration Building, #122 Zhenhua RD., Futian, Shenzhen, China



General Description

The AOZ1934/5 is an ideal power solution for white LED backlighting for medium to small size LCD panels. It is a highly integrated step up DC-DC converter with input voltage range from 2.7V to 25V, accommodating 1-, 2-, 3-, or 4-cell lithium ion batteries or 3.3V, 5V, 12V or 20V regulated supplies. The AOZ1934/5 integrates a 40V power MOSFET as well as compensation and soft start circuitry, which results in a simpler and smaller solution with much fewer external components. A high switching frequency (800kHz) allows the use of a smaller inductor and capacitor to further reduce the solution size.

Each of the regulated current sinks in the AOZ1934/5 provides 20mA factory programmed current. With a maximum of 40V at the output of the step-up converter, each string can connect up to ten LEDs in series, for a total of 20 LEDs for AOZ1934 and 30 LEDs for AOZ1935.

The AOZ1934/5 is equipped with fast PWM dimming control for wide dimming range and has an enable pin for IC ON/OFF control. Various protection features are built into the AOZ1934/5, including cycle-by-cycle input current limit protection, output over-voltage protection, LED fault (open or short) protection and thermal shutdown protection. The leakage current in shutdown mode is 0.1 μ A.

The AOZ1934/5 is available in a 16-lead 3 x 3 x 0.75mm thin QFN package.

Features

- Wide input range: 2.7V to 25V
- Drive up to 30 LEDs
 - AOZ1934 up to 20 LEDs (10s2p)
 - AOZ1935 up to 30 LEDs (10s3p)
- Up to 92% efficiency
- High frequency step-up converter (800kHz)
- Highly integrated solution
 - Integrated 40V Power MOSFET
 - Internal compensation and soft start
- Integrated current sinks:
 - AOZ1934 – 2 channels, AOZ1935 – 3 channels
 - $\pm 2\%$ Typ. current accuracy
 - 1.5% Typ. current matching
- PWM dimming with $< 1\mu$ s delay time
- Low operating quiescent current (500 μ A)
- LED open/short protection
- Both internal fixed and external adjustable Over-voltage protection
- Cycle-by-cycle inductor current limit (2.5A)
- 0.1 μ A shutdown current
- Green Package: 3 x 3 QFN-16
- -40°C to +85°C temperature range

Applications

- Netbook
- Tablet PCs
- GPS
- Portable media players
- 1-, 2-, 3-, 4-cell Li Ion LED applications



Typical Application Circuit

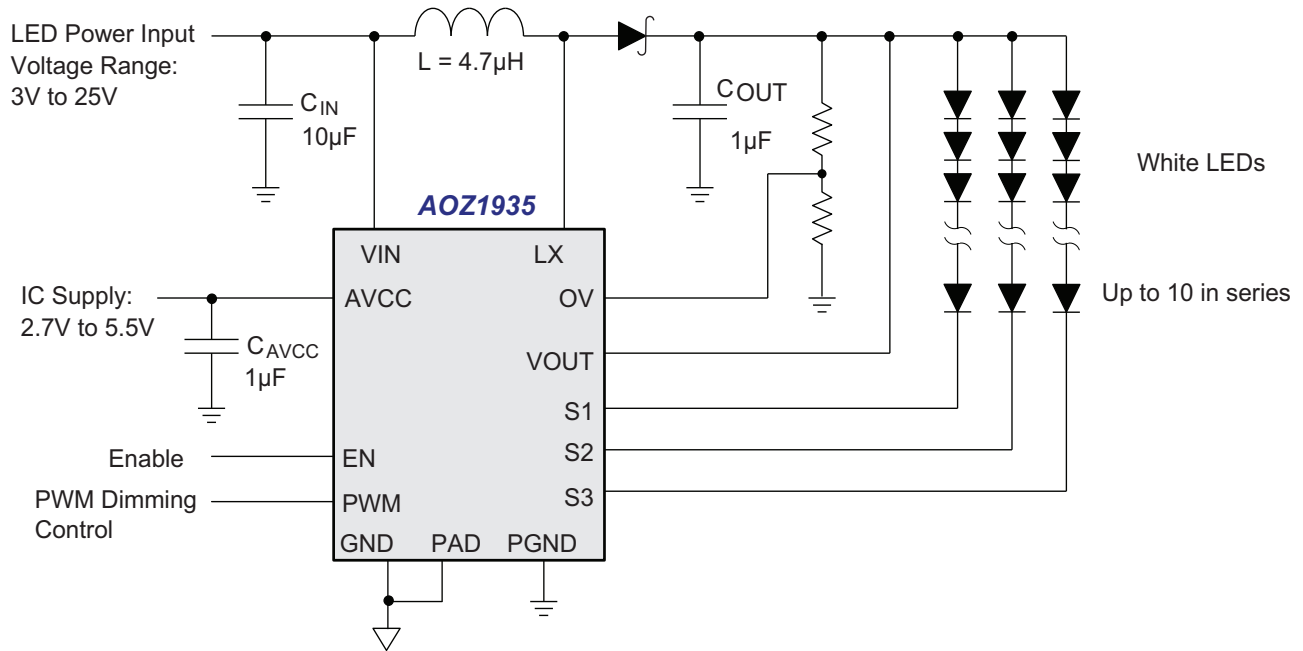

Ordering Information

Part Number	Ambient Temperature Range	Package	Environmental
AOZ1934QI*	-40°C to +85°C	3x3 QFN-16	Green Product
AOZ1935QI	-40°C to +85°C	3x3 QFN-16	Green Product

*Contact manufacturer for product availability



AOS Green Products use reduced levels of Halogens, and are also RoHS compliant. Please visit www.aosmd.com/media/AOSGreenPolicy.pdf for additional information.

Pin Configuration

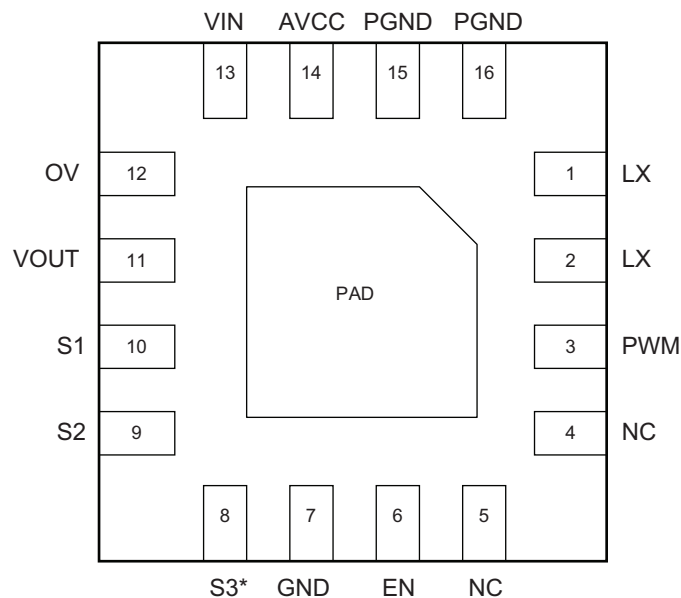

3x3 QFN-16
(Bottom View)

Pin Description

Pin Number	Pin Name	Pin Function
1, 2	LX	Switching node of the step-up converter
3	PWM	Pulse width controlled dimming input. Connect this pin to AVCC when not used
4, 5	NC	Not internally connected
6	EN	IC enable
7	GND	Analog Ground pin
8	S3*	Regulated output current sink #3*
9	S2	Regulated output current sink #2
10	S1	Regulated output current sink #1
11	VOUT	Output voltage sense pin
12	OV	Over voltage feedback sense pin. Programmable with a resistor divider, this pin has an internal 1.2V threshold
13	VIN	Boost converter power supply's input voltage sense pin
14	AVCC	Input supply pin for the IC
15, 16	PGND	Power Ground pin
PAD		Exposed Backside Paddle. Connect to ground for electrical and thermal usage. PAD is internally connected to Analog Ground pin.

*S3 is only for the AOZ1935.

Functional Block Diagram

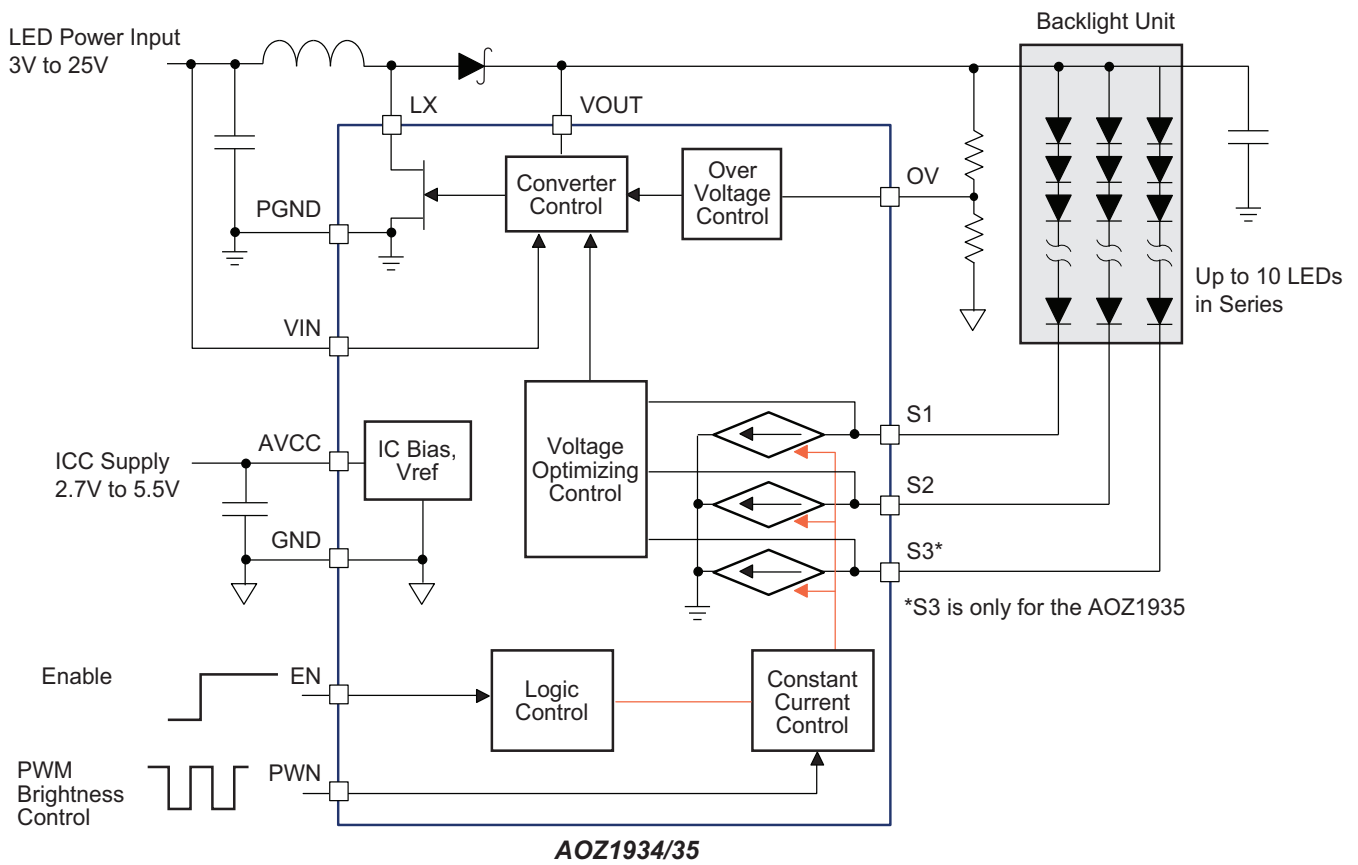

Absolute Maximum Ratings ($T_A=25^\circ\text{C}$ unless otherwise noted⁽¹⁾)

Exceeding the Absolute Maximum ratings may damage the device.

Symbol	Description	Value	Unit
VIN	Boost Converter Input Voltage	-0.3 to 28	V
AVCC	IC Input Voltage	-0.3 to 6	V
LX, Sx	High Voltage Nodes	-0.3 to 44	V
VOUT	Output Voltage Node	-0.3 to 44	
EN, PWM, OV	Input Nodes	-0.3 to AVCC+0.3	V
T_J	Operating Temperature Range	-40 to 150	$^\circ\text{C}$
T_S	Storage Temperature Range	-65 to 150	$^\circ\text{C}$
T_{LEAD}	Maximum Soldering Temperature (at leads, 10 seconds)	300	$^\circ\text{C}$
ESD	Human Body Model	2	kV

Note:

1. Stresses above those listed in Absolute Maximum Ratings may cause permanent damage to the device. Functional operation at conditions other than the operating conditions specified is not implied. Only one Absolute Maximum rating should be applied at any one time.

Thermal Capabilities

Symbol	Description	Value	Unit
Θ_{JA}	Thermal Resistance – Junction to Ambient ⁽²⁾	50	$^\circ\text{C}/\text{W}$
P_D	Maximum Power Dissipation at $T_A \leq 25^\circ\text{C}$	2.0	W
$P_D / \Delta T$	Derating Factor Above $T_A = 25^\circ\text{C}$	-20	mW/ $^\circ\text{C}$

Note:

2. Junction to Ambient thermal resistance is highly dependent on PCB layout. Values are based on thermal properties of the device when soldered to an EV board.

Electrical Characteristics

Symbol	Parameter	Condition	Min.	Typ.	Max.	Units
IC SUPPLY						
V_{IN}	Boost Converter Input Range		2.7		25	V
AVCC	IC Supply Voltage Range		2.7		5.5	V
UVLO	IC Supply Under Voltage Lockout	Rising Edge		2.5	2.65	V
UVLO _{HYST}	UVLO Hysteresis			0.15		V
I_Q	IC Standby Current	Not Switching		0.5		mA
	IC Operating Current	Switching		1.15		mA
I_{SHDN_AVCC}	AVCC Pin Shutdown Current	EN = GND		0.1	1.0	μ A
I_{SHDN_VIN}	V_{IN} Pin Shutdown Current	EN = GND		0.1	1.0	μ A
STEP-UP CONVERTER						
$R_{DS(ON)}$	NMOS On-resistance			0.35		Ω
I_{LIM}	Peak NMOS Current Limit			2.5		A
F_{SW}	Oscillator Frequency			800		kHz
D_{max}	Maximum Duty Cycle		92	95		%
V_{OV}	OV Pin Threshold			1.2		V
V_{OVP}	Internal OVP – V_{OUT} Threshold			40		V
T_S	Start-up Time			1		ms
CURRENT SINK						
I_D	Output Current Accuracy	Current Setting = 20mA (DATA = 1), $T_A=25^\circ\text{C}$		± 1	± 4	%
		Current Setting = 20mA (DATA = 1)		± 1	± 6	
	Output current matching ⁽³⁾	Current Setting = 20mA (DATA = 1)		1.5	3.5	%
V_{SOV}	Current Sink Over-voltage Threshold			6.0		V
T_{FAULT}	Current Sink Fault Delay	PWM 100% Duty Cycle		80		ms
CONTROL						
V_{TH-L}	EN, PWM Pin Logic Low Threshold				0.4	V
V_{TH-H}	EN, PWM Pin Logic High Threshold		1.4			V
$T_{PWM(ON)_MIN}$	Minimum PWM On Time			1		μ s
F_{PWM}	PWM Dimming Frequency		100		30000	Hz
T_{J-TH}	IC Junction Thermal Shutdown Threshold			150		$^\circ\text{C}$
	IC Junction Thermal Shutdown Hysteresis			15		$^\circ\text{C}$

Note:

- The device is guaranteed to meet performance specifications over the -40°C to $+85^\circ\text{C}$ operating temperature range by design, characterization and correlation with statistical process controls.
- The current matching between channels is defined as $|I_D - I_{AVG}|_{max} / I_{AVG}$.

Typical Operating Characteristics

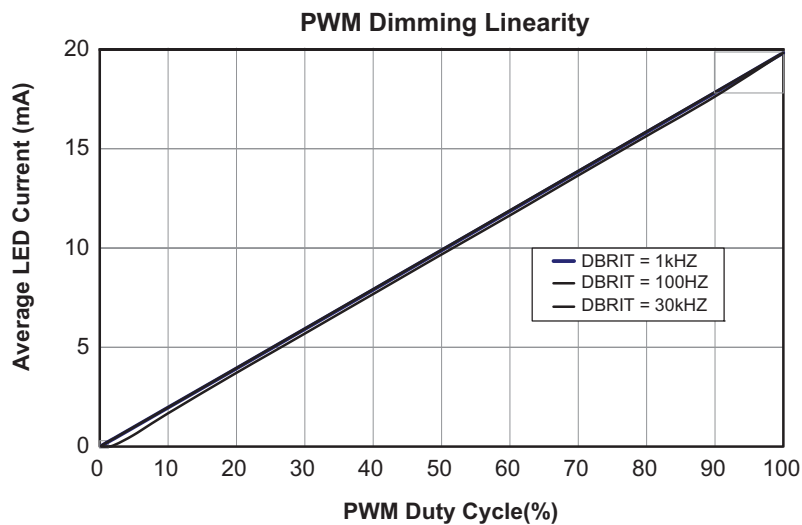
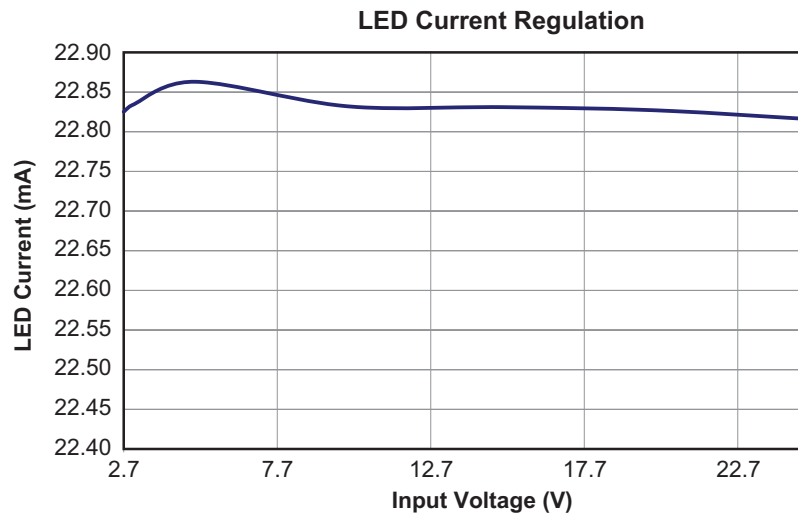
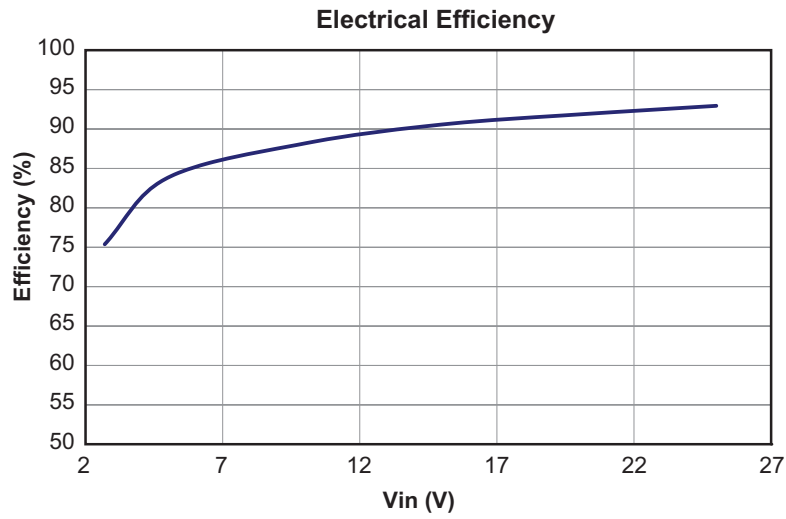

Typical Operating Characteristics (Continued)

Start-up Waveform
($V_{IN} = 5V$, Full Brightness)

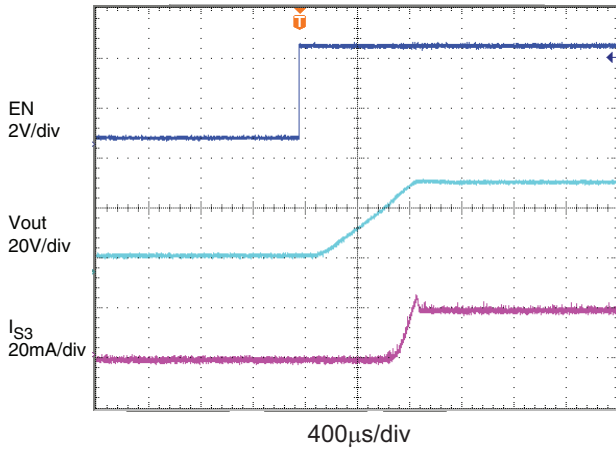

Switching Waveform
($V_{IN} = 2.7V$, Full Brightness)

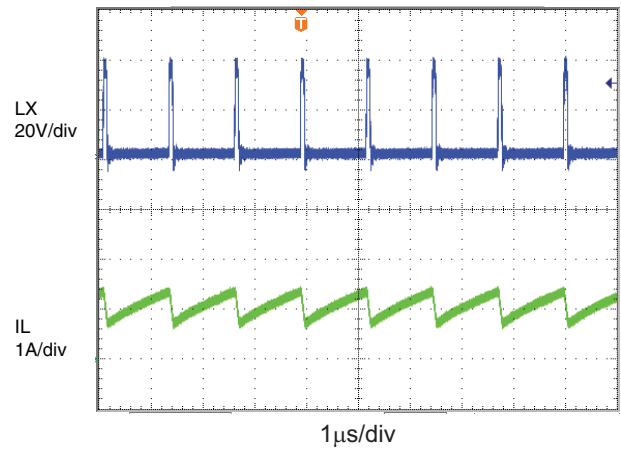

Switching Waveform
($V_{IN} = 3.6V$, Full Brightness)

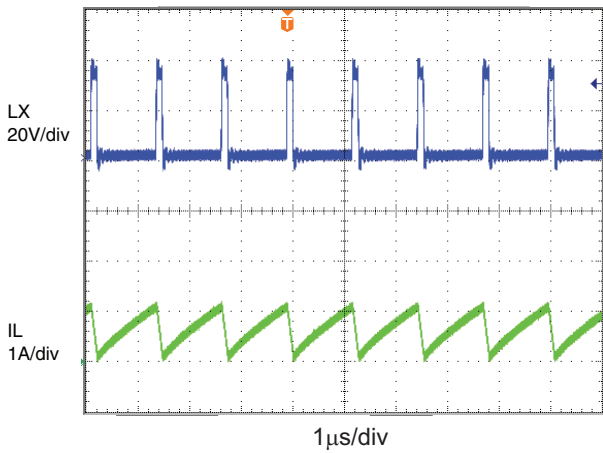

Switching Waveform
($V_{IN} = 5V$, Full Brightness)

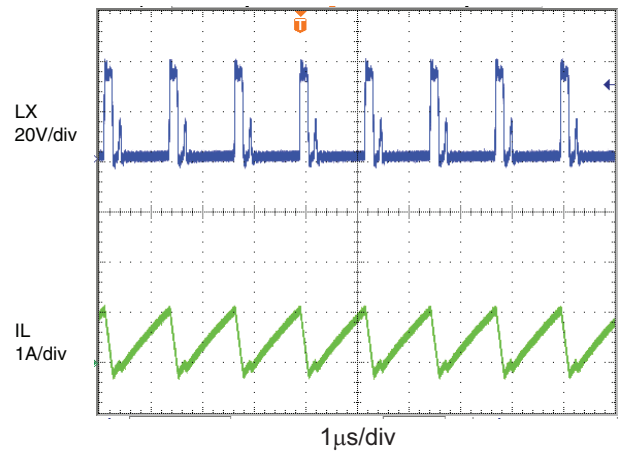

Switching Waveform
($V_{IN} = 12V$, Full Brightness)

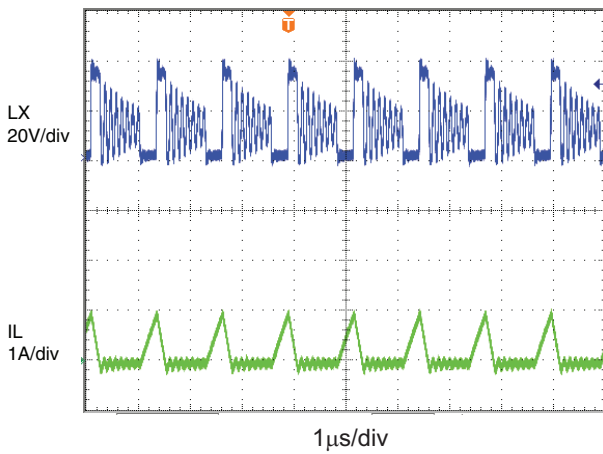

Switching Waveform
($V_{IN} = 25V$, Full Brightness)

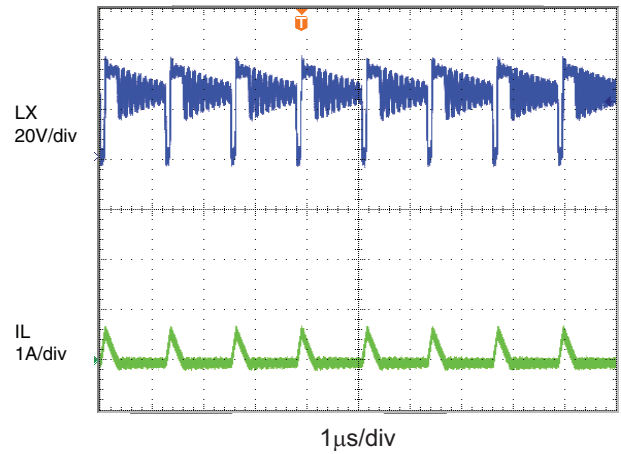

Typical Operating Characteristics (Continued)

PWM Dimming 10%
($V_{IN} = 3.6V$, Frequency = 20kHz)

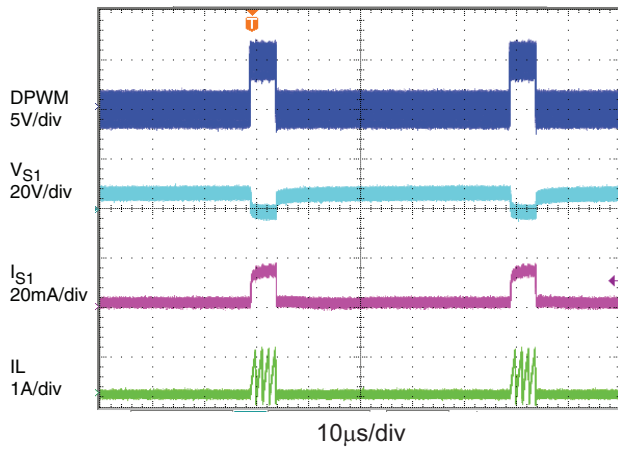

PWM Dimming 10%
($V_{IN} = 5V$, Frequency = 20kHz)

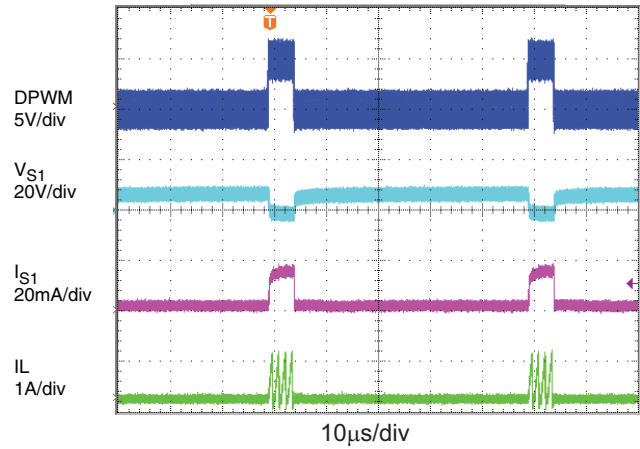

PWM Dimming 50%
($V_{IN} = 3.6V$, Frequency = 20kHz)

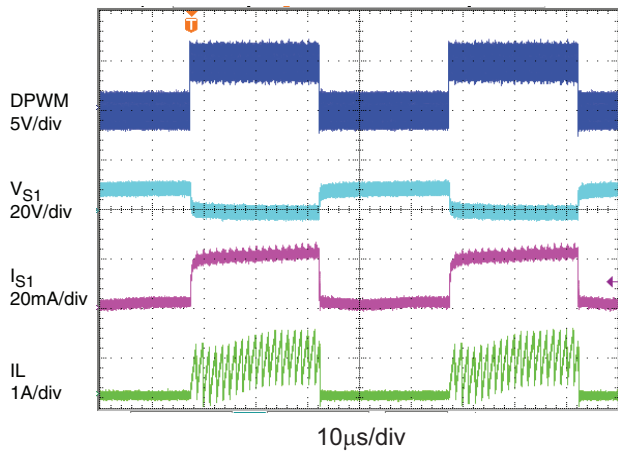

PWM Dimming 50%
($V_{IN} = 5V$, Frequency = 20kHz)

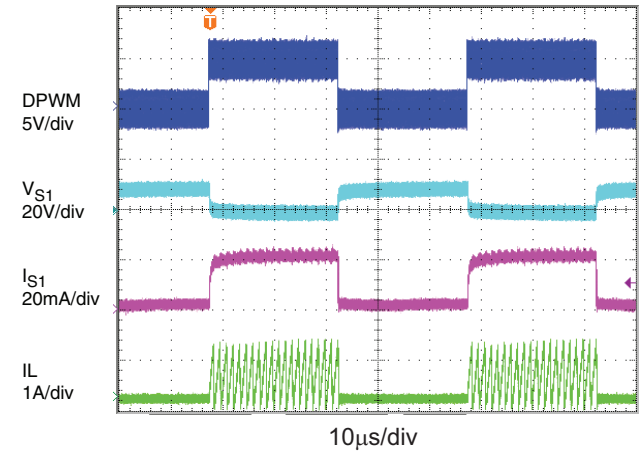

PWM Dimming 90%
($V_{IN} = 3.6V$, Frequency = 20kHz)

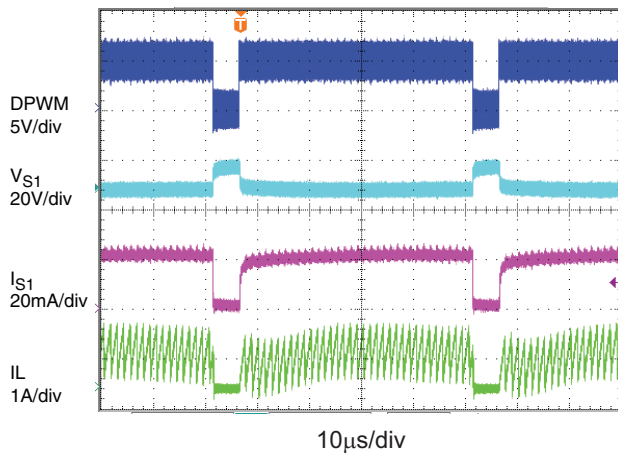

PWM Dimming 90%
($V_{IN} = 5V$, Frequency = 20kHz)

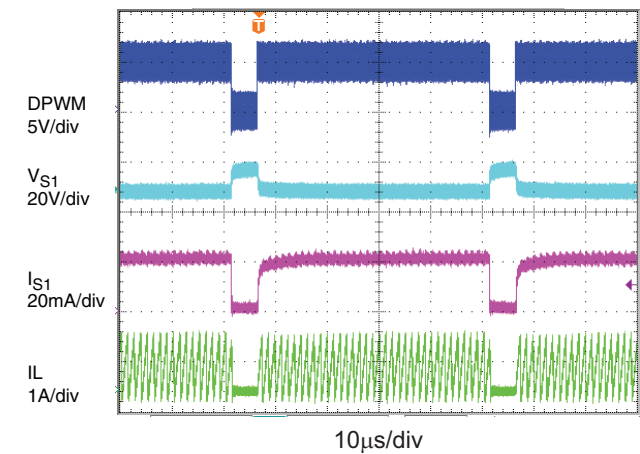

Typical Operating Characteristics (Continued)

Output, Short-to-Ground
($V_{IN} = 5V$, Full Brightness)

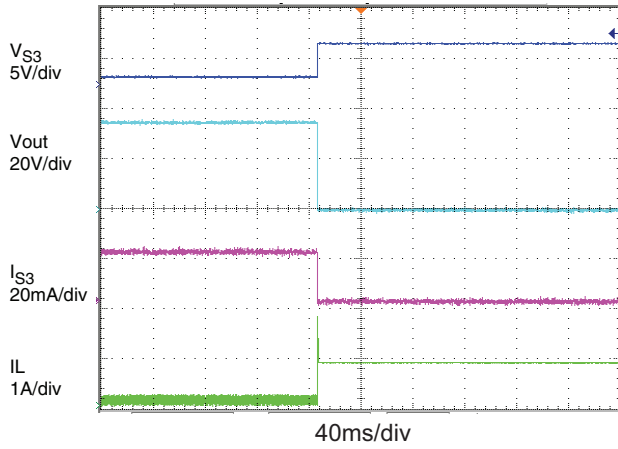

LED Open Protection
($V_{IN} = 5V$, Full Brightness)

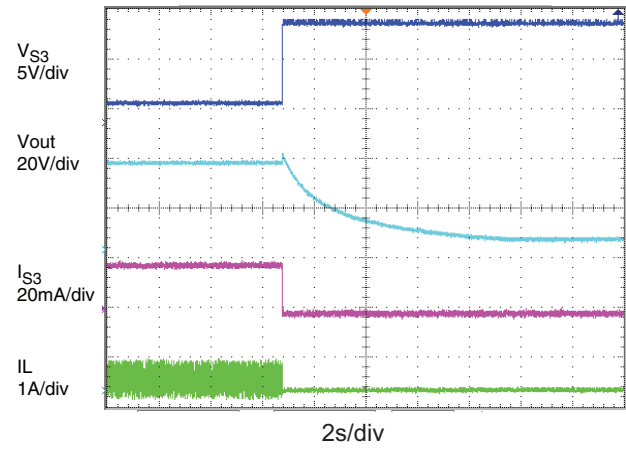

LED Short Protection
($V_{IN} = 5V$, Full Brightness)

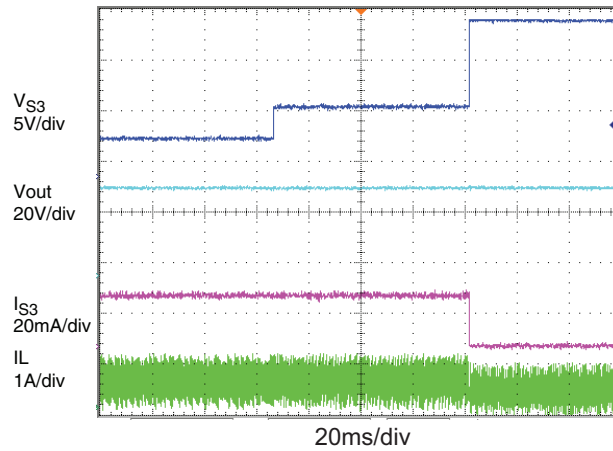

Detailed Description

The AOZ1934/5 is a unique current regulated step-up (boost) converter. Two (or three for AOZ1935) current regulating devices are integrated to drive two or three strings of LEDs. Unused channels need to be connected to ground (GND).

The voltage step-up is accomplished by a boost topology, using an inductor-based DC-DC switching converter, in which the inductor serves as an energy storage device in the system. By integrating a high voltage optimized MOSFET, the AOZ1934/5 internal switching frequency is 800kHz while still maintaining high power efficiency. Unlike a traditional DC-DC boost converter with a fixed output voltage, the AOZ1934/5 dynamically changes its output voltage regulation parameters depending on the load. The use of unique control schemes maintains accurate current regulation in each current sink while leaving the output voltage at a minimum, increasing the overall conversion efficiency. The internal step-up converter dynamically controls the voltage at the output high enough to drive the LED string with the highest total forward voltage. The wide input voltage range, from 2.7V to 25V, allows maximum system flexibility; battery powered devices using 1-, 2-, 3- or 4-cell Li Ion packs can share the same power architecture. A low power 2.7V to 5.5V input to supply the IC bias circuitry is required at AVCC pin.

LED brightness control is based on the popular PWM dimming scheme via the PWM pin. The EN pin provides ON/OFF control of the IC. By asserting a logic high on the EN pin, the converter is enabled and will regulate each of the current sinks at the factory programmed current setting.

Application Information

Power Up Sequence

It's recommended to power up V_{in} , AVCC, and PWM dimming in sequence, and EN pin needs to ramp up simultaneously or later than AVCC, in order to avoid latch-off, or mis-operation of device. We do not assume any liability or responsibility for any loss or damage arising from misuse or inappropriate use of the product.

Current Dimming Using PWM Pin

AOZ1934/5 allows maximum flexibility with a PWM signal control input which can be used for dimming. The IC must remain Enabled at EN pin during PWM dimming, which means the step-up converter is active to reduce the response time. Combining this with the fast response of the step-up converter, each LED channel can typically

recover from no current within $1\mu s$. This allows very short PWM on-time or a duty-cycle with fine resolution. Assume a $50\mu s$ minimum on-time for a 100Hz PWM signal, a 200:1 ratio can be achieved by PWM. The minimum PWM on-time of $1\mu s$ is required in AOZ1934/5's application, this means minimum PWM duty cycle of 2% for 20kHz dimming frequency and 0.02% for 200Hz dimming frequency. The amplitude of PWM signal should not be higher than AVCC, otherwise test mode will be triggered.

Fault Protection (LED Open or Short)

Each current sink is protected against LED short or open conditions. If an LED short circuit condition arises, the current sink continues to regulate until $V_{SINK} > V_{SOV}$ (6V). When any sink node voltage goes above V_{SOV} for more than 80ms (while PWM dimming signal remains high), that channel's current sink will be turned off, and other channels will still work if they don't trigger this fault condition. For example, if one or more LEDs on a channel are shorted, that channel's sink voltage will increase. If the voltage goes above 6V for more than 80ms, the Current Sink Fault Protection will be triggered and only this faulty string will be disabled by shutting off this current sink. All other channels will continue normal operation if they don't have a fault condition. When PWM dimming control is used, the 80ms fault delay is accumulated only when PWM signal is high; the PWM low time is not counted into the fault delay, so the delay time will be $80ms / D_{PWM}$ (D_{PWM} is the duty cycle of the PWM signal).

In case of an LED failing open, the current sink voltage of the failed string will go close to ground and dominate the boost converter control loop. As a result the output voltage will move up to the over-voltage threshold, set internally to 40V or by the external resistor divider, whichever is lower. Once the over-voltage incident is flagged internally, the faulty channel(s) will be disabled. Then the output voltage of the boost converter will go back to normal level. During the entire process, the rest of the LED strings (healthy LED strings) would continue normal operation.

The fault conditions are reset when the IC is powered down and up again.

Output Over-Voltage Protection (OVP)

AOZ1934/5 has built in over-voltage protection function with 40V threshold at VOUT pin. This level is suitable for applications with ten series LEDs per string. However, for applications with fewer series LEDs, the user can choose

to program a lower over-voltage threshold using the OV pin. The internal reference voltage to trigger OVP at OV pin is 1.2V; a resistor divider can be connected as shown in the following figure and the over voltage threshold can be derived as

$$V_{OUT_OV} = 1.2 \times \left(1 + \frac{R_1}{R_2} \right)$$

To limit the leakage current through the divider, make sure $10M > R_1 + R_2 > 1M$. The lower value of the internal 40V OVP and the external OVP set by the resistor divider determines the system OVP value.

Thermal Shutdown

Thermal shutdown feature is also included in the AOZ1934/5. When IC junction temperature (T_j) reaches 150°C, the IC will immediately enter shutdown mode. Once T_j drops 15°C to around 135°C, the IC will be back to normal operation.

Inductor Selection

A 4.7µH to 10µH inductor is recommended for all the applications. If high efficiency is a critical requirement, a low DCR inductor should be selected. The inductor's saturation current rating should also exceed the peak input current.

Capacitor Selection

Small size ceramic capacitors with low ESR are ideal for all the applications. A 10µF input capacitor at VIN, a 1µF input capacitor at AVCC and a 1µF output capacitor at VOUT are suggested. The voltage rating of these capacitors should exceed the maximum possible voltage at the corresponding pins. For example, for the application of 3P10S LEDs from input voltage range of 5V to 22V and AVCC = 3.3V, a 25V capacitor is recommended at the VIN pin, a 50V capacitor is recommended at the VOUT pin, and a 10V capacitor is recommended at the AVCC pin.

Diode Selection

Using a schottky diode is recommended because of its low forward voltage drop and fast reverse recovery time. The current rating of the schottky diode should exceed the peak current of the boost converter. The voltage rating should also exceed the target output voltage. For applications driving 10 LEDs in series, 50V voltage rating schottky diode is recommended.

Layout Considerations

PCB layout is very important for high frequency switching regulators in order to keep the loop stable and minimize noise. The AVCC pin's capacitor should be very close to the IC to get the best decoupling. The path of the inductor, schottky diode and output capacitor should be kept as short as possible to minimize noise and ringing. Please see the AOZ1934/5 evaluation document for detailed PCB layout guidelines.

Package Dimensions, QFN-16 3mm x 3mm x 0.75mm

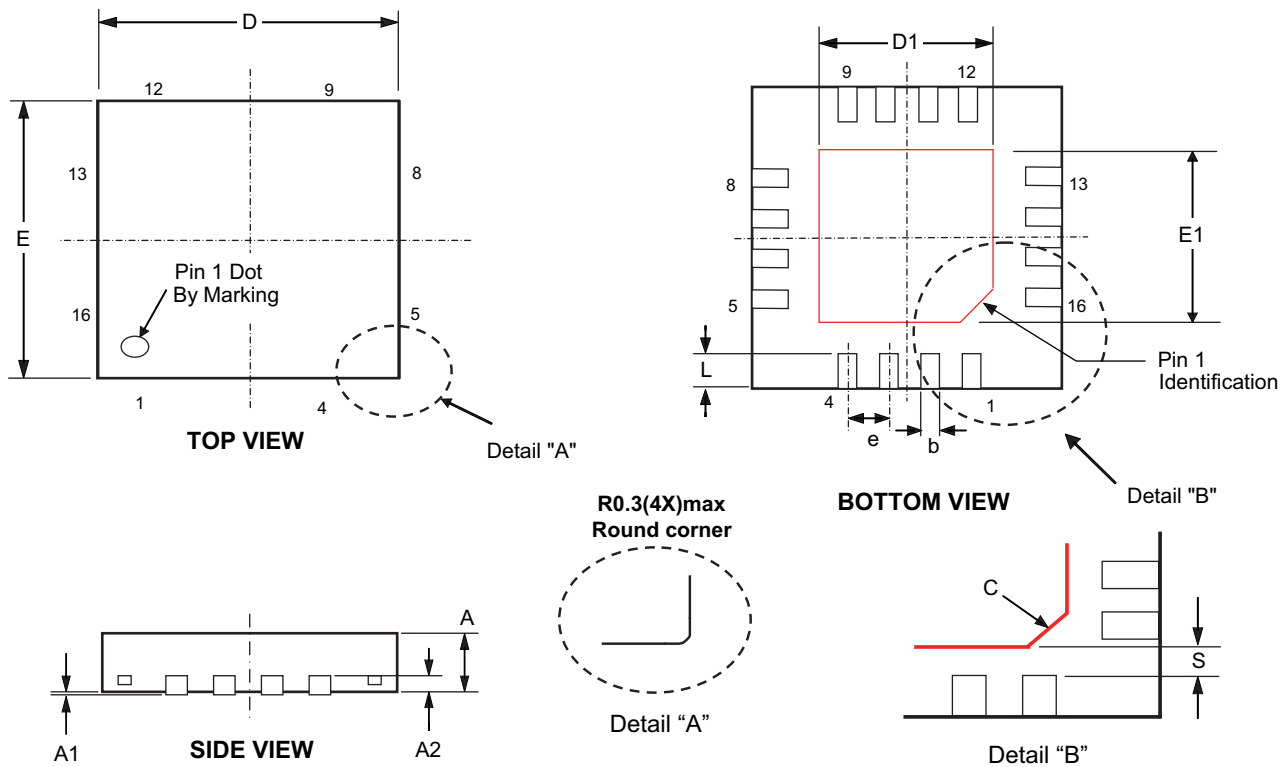

Dimensions in millimeters

Symbols	Min.	Nom.	Max.
A	0.65	0.75	0.85
A1	0.000	0.025	0.050
A2	0.154	0.203	0.280
b	0.18	0.23	0.30
C	0.3 Ref.		
D	2.95	3.00	3.05
D1	1.7 Ref.		
E	2.95	3.00	3.05
E1	1.7 Ref.		
e	0.45	0.50	0.55
L	0.30	0.40	0.50
S	0.25 Ref		

Dimensions in inches

Symbols	Min.	Nom.	Max.
A	0.026	0.030	0.033
A1	0.000	0.001	0.002
A2	0.006	0.008	0.011
b	0.007	0.009	0.012
C	0.012 Ref.		
D	0.116	0.118	0.120
D1	0.067 Ref.		
E	0.116	0.118	0.120
E1	0.067 Ref.		
e	0.018	0.020	0.022
L	0.012	0.016	0.020
S	0.010 Ref.		

Note:

1. Controlling dimension is millimeter, converted inch dimensions are not necessarily exact.

Tape and Reel Dimensions, QFN-16 3mm x 3mm x 0.75mm

Carrier Tape

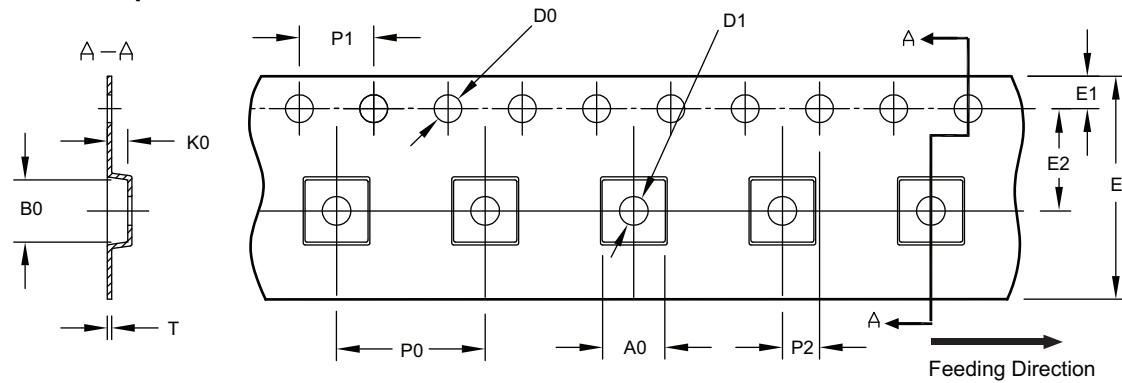

UNIT: mm

Package	A0	B0	K0	D0	D1	E	E1	E2	P0	P1	P2	T
DFN 3x3 EP	3.40 ±0.10	3.35 ±0.10	1.10 ±0.10	1.50 +0.10/-0	1.50 +0.10/-0	12.00 ±0.30	1.75 ±0.10	5.50 ±0.05	8.00 ±0.10	4.00 ±0.10	2.00 ±0.05	0.30 ±0.05

Reel

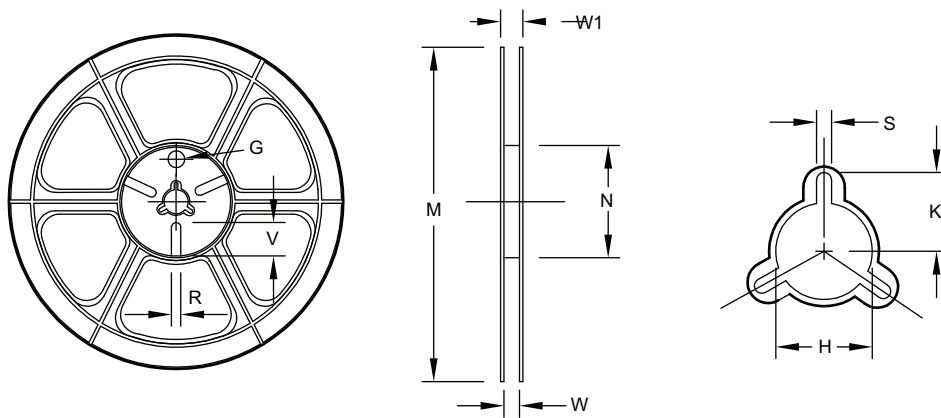

UNIT: mm

Tape Size	Reel Size	M	N	W	W1	H	K	S	G	R	V
12mm	ø330	ø330.0 ±0.50	ø97.00 ±0.10	13.00 ±0.30	17.40 ±1.00	ø13.0 +0.50/-0.20	10.60	2.00 ±0.50	—	—	—

Leader/Trailer and Orientation

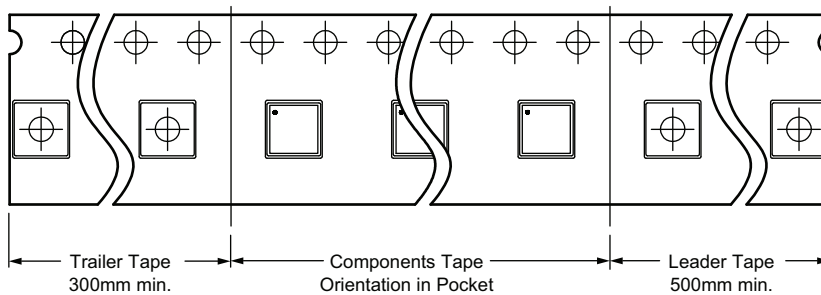

Part Marking

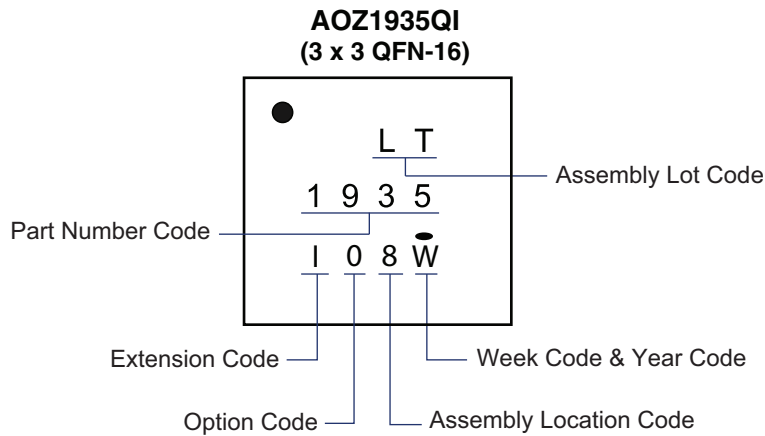

LEGAL DISCLAIMER

Alpha and Omega Semiconductor makes no representations or warranties with respect to the accuracy or completeness of the information provided herein and takes no liabilities for the consequences of use of such information or any product described herein. Alpha and Omega Semiconductor reserves the right to make changes to such information at any time without further notice. This document does not constitute the grant of any intellectual property rights or representation of non-infringement of any third party’s intellectual property rights.

LIFE SUPPORT POLICY

ALPHA AND OMEGA SEMICONDUCTOR PRODUCTS ARE NOT AUTHORIZED FOR USE AS CRITICAL COMPONENTS IN LIFE SUPPORT DEVICES OR SYSTEMS.

As used herein:

- | | |
|---|---|
| <p>1. Life support devices or systems are devices or systems which, (a) are intended for surgical implant into the body or (b) support or sustain life, and (c) whose failure to perform when properly used in accordance with instructions for use provided in the labeling, can be reasonably expected to result in a significant injury of the user.</p> | <p>2. A critical component in any component of a life support, device, or system whose failure to perform can be reasonably expected to cause the failure of the life support device or system, or to affect its safety or effectiveness.</p> |
|---|---|