



Chipsmall Limited consists of a professional team with an average of over 10 year of expertise in the distribution of electronic components. Based in Hongkong, we have already established firm and mutual-benefit business relationships with customers from,Europe,America and south Asia,supplying obsolete and hard-to-find components to meet their specific needs.

With the principle of “Quality Parts,Customers Priority,Honest Operation,and Considerate Service”,our business mainly focus on the distribution of electronic components. Line cards we deal with include Microchip,ALPS,ROHM,Xilinx,Pulse,ON,Everlight and Freescale. Main products comprise IC,Modules,Potentiometer,IC Socket,Relay,Connector.Our parts cover such applications as commercial,industrial, and automotives areas.

We are looking forward to setting up business relationship with you and hope to provide you with the best service and solution. Let us make a better world for our industry!



Contact us

Tel: +86-755-8981 8866 Fax: +86-755-8427 6832

Email & Skype: info@chipsmall.com Web: www.chipsmall.com

Address: A1208, Overseas Decoration Building, #122 Zhenhua RD., Futian, Shenzhen, China



General Description

The AOZ8001A is a transient voltage suppressor array designed to protect high speed data lines from ESD and lightning.

This device incorporates four surge rated, low capacitance steering diodes and a TVS in a single package. During transient conditions, the steering diodes direct the transient to either the positive side of the power supply line or to ground. They may be used to meet the ESD immunity requirements of IEC 61000-4-2, Level 4. The TVS diodes provide effective suppression of ESD voltages up to $\pm 30\text{kV}$ (air discharge) and $\pm 30\text{kV}$ (contact discharge).

The AOZ8001A comes in RoHS compliant, SOT-143 package and is rated over a -40°C to $+85^{\circ}\text{C}$ ambient temperature range. It is compatible with both lead free and SnPb assembly techniques.

The very small SOT-143 package is ideal for applications where PCB space is a premium. The small size, low capacitance and high ESD protection makes it ideal for protecting high speed video and data communication interfaces.

Features

- ESD protection for high-speed data lines:
 - AOZ8001AJI 5V:
 - IEC 61000-4-2, level 4 (ESD) immunity test
 - $\pm 30\text{kV}$ (air discharge) and $\pm 30\text{kV}$ (contact discharge)
 - IEC 61000-4-5 (Lightning) 18A (8/20 μs)
 - Human Body Model (HBM) $\pm 30\text{kV}$
 - AOZ8001AJI 12V:
 - IEC61000-4-2, Level 4 (ESD) immunity test
 - $\pm 30\text{kV}$ (air discharge) and $\pm 30\text{kV}$ (contact discharge)
 - IEC61000-4-5 (Lightning) $\pm 13\text{A}$ (8/20 μs)
 - Human Body Model (HBM) $\pm 30\text{kV}$
- Small package saves board space
- Low insertion loss
- Protects two I/O lines
- Low capacitance from IO to Ground: 1.8pF
- Low clamping voltage
- Low operating voltages: 5V, 12V

Applications

- USB 2.0 power and data line protection
- Video graphics cards
- Monitors and flat panel displays
- Digital Video Interface (DVI)
- 10/100/1000 Ethernet
- Notebook computers



Typical Application

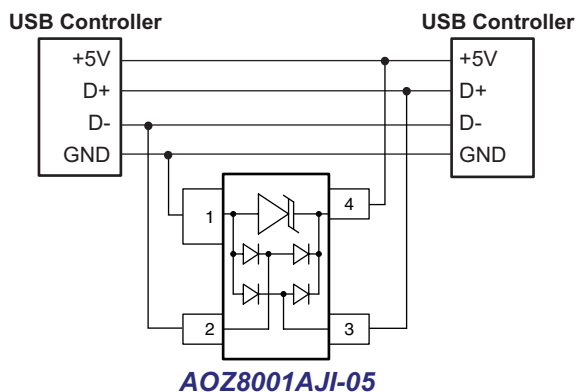

Figure 1. USB 2.0 High Speed Port

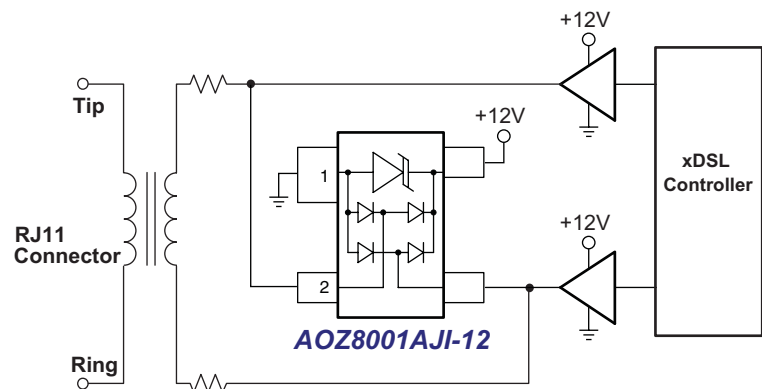

Figure 2. xDSL Application

Ordering Information

Part Number	Ambient Temperature Range	Package	Environmental
AOZ8001AJI-05	-40°C to +85°C	SOT-143	RoHS Compliant Green Product
AOZ8001AJI-12	-40°C to +85°C	SOT-143	RoHS Compliant Green Product



AOS Green Products use reduced levels of Halogens, and are also RoHS compliant. Please visit www.aosmd.com/web/quality/rohs_compliant.jsp for additional information.

Pin Configuration

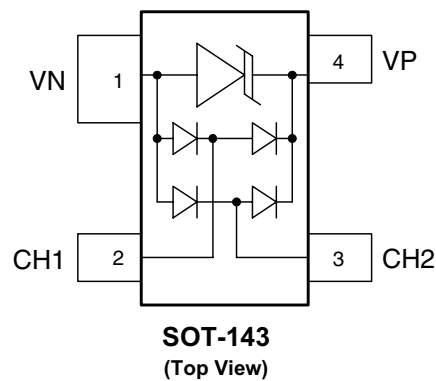

Absolute Maximum Ratings

Exceeding the Absolute Maximum ratings may damage the device.

Parameter	Rating
Storage Temperature (T_S)	-65°C to +150°C

Maximum Transient Rating

Device	HBM ⁽¹⁾	ESD (Contact) ⁽²⁾	ESD (Air) ⁽²⁾	Surge (8/20 μ s)
AOZ8001AJI-05	± 30 kV	± 30 kV	± 30 kV	± 18 A
AOZ8001AJI-12	± 30 kV	± 30 kV	± 30 kV	± 13 A

Notes:

- Human Body Discharge per MIL-STD-883, Method 3015 $C_{Discharge} = 100$ pF, $R_{Discharge} = 1.5$ k Ω .
- IEC 61000-4-2 discharge with $C_{Discharge} = 150$ pF, $R_{Discharge} = 330$ Ω .

Maximum Operating Ratings

Parameter	Rating
Junction Temperature (T_J)	-40°C to +125°C

Electrical Characteristics

$T_A = 25^\circ\text{C}$ unless otherwise specified.

Symbol	Parameter	Diagram
I_{PP}	Reverse Peak Pulse Current	
$V_{CL}^{(5)(7)}$	Clamping Voltage @ I_{PP}	
$V_{RWM}^{(3)}$	Working Peak Reverse Voltage	
I_R	Maximum Reverse Leakage Current @ V_{RWM}	
$V_{BR}^{(4)}$	Breakdown Voltage	
I_F	Forward Current	
V_F	Forward Voltage	
P_{PK}	Peak Power Dissipation	
$C_J^{(6)}$	I/O-GND Capacitance @ $V_R = 0$ and $f = 1\text{MHz}$	

Device	Device Marking	V_{RWM} (V) Max.	V_{BR} (V) Typ. @ 1mA	I_R (μA) Max.	V_F (V) Typ.	V_{CL} Max.			C_J (pF) Typ.	C_J (pF) Max.
						$I_{PP} = 1\text{A}$	$I_{PP} = 5\text{A}$	$I_{PP} = 12\text{A}$		
AOZ8001AJI-05	AD	5.5	8.5	1.0	0.85	12.50	15.00	16.00	1.80	2.50
AOZ8001AJI-12	AD	12.5	15.0	1.0	0.85	16.00	18.00	19.00	1.80	2.50

Notes:

- The working peak reverse voltage, V_{RWM} , should be equal to or greater than the DC or continuous peak operating voltage level.
- V_{BR} is measured at the pulse test current I_T .
- Measurements performed with no external capacitor on V_P (pin 4 floating).
- Measurements performed with V_P biased to 3.3 Volts (pin 4 @ 3.3V).
- Measurements performed using a 100ns Transmission Line Pulse (TLP) system.

Typical Performance Characteristics

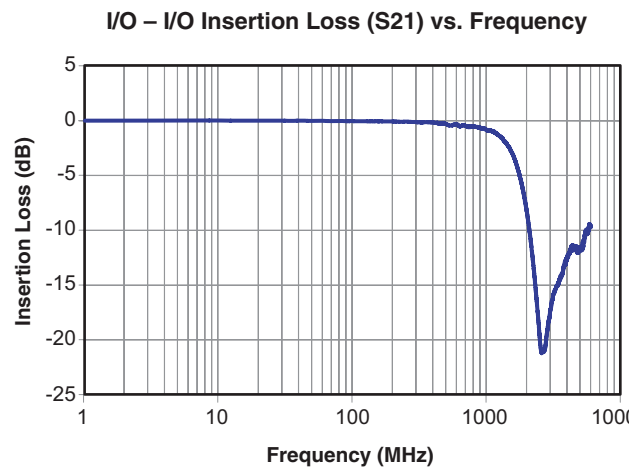
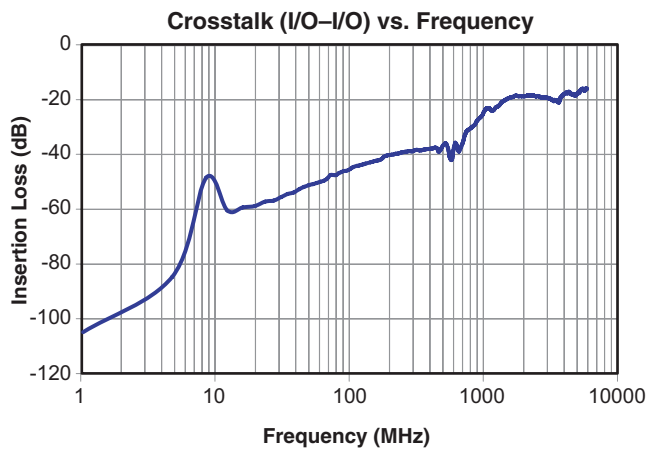
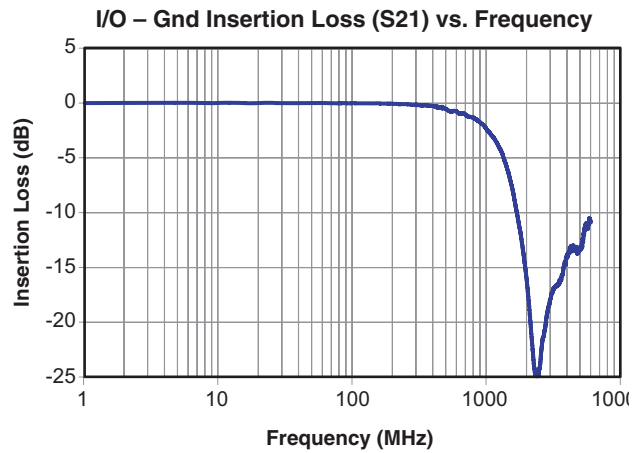
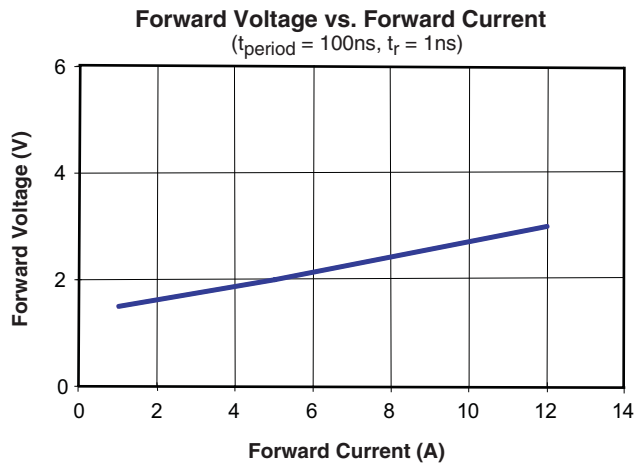
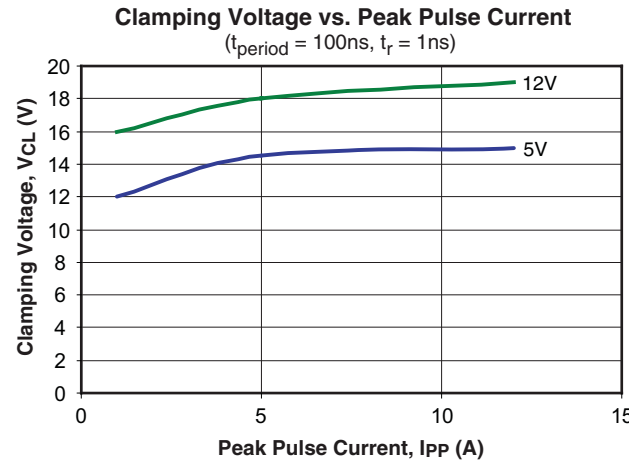
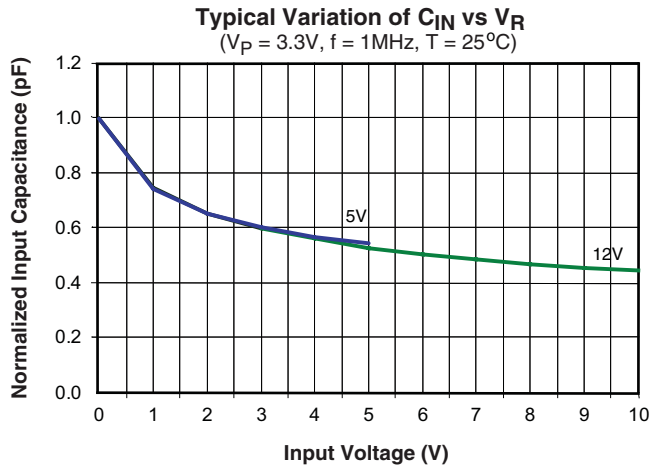

Application Information

The AOZ8001A TVS is design to protect two data lines from fast damaging transient over-voltage by clamping it to a reference. When the transient on a protected data line exceed the reference voltage the steering diode is forward bias thus, conducting the harmful ESD transient away from the sensitive circuitry under protection.

PCB Layout Guidelines

Printed circuit board layout is the key to achieving the highest level of surge immunity on power and data lines. The location of the protection devices on the PCB is the simplest and most important design rule to follow. The AOZ8001A devices should be located as close as possible to the noise source. The placement of the AOZ8001A devices should be used on all data and power lines that enter or exit the PCB at the I/O connector. In most systems, surge pulses occur on data and power lines that enter the PCB through the I/O connector. Placing the AOZ8001A devices as close as possible to the noise source ensures that a surge voltage will be clamped before the pulse can be coupled into adjacent PCB traces. In addition, the PCB should use the shortest possible traces. A short trace length equates to low impedance, which ensures that the surge energy will be dissipated by the AOZ8001A device. Long signal traces will act as antennas to receive energy from fields that are produced by the ESD pulse. By keeping line lengths as short as possible, the efficiency of the line to act as an antenna for ESD related fields is reduced. Minimize inter-connecting line lengths by placing devices with the most interconnect as close together as possible. The protection circuits should shunt the surge voltage to either the reference or chassis ground. Shunting the surge voltage directly to the IC's signal ground can cause ground bounce. The clamping performance of TVS diodes on a single ground PCB can be improved by minimizing the impedance with relatively short and wide ground traces. The PCB layout and IC package parasitic inductances can cause significant overshoot to the TVS's clamping voltage. The inductance of the PCB can be reduced by

using short trace lengths and multiple layers with separate ground and power planes. One effective method to minimize loop problems is to incorporate a ground plane in the PCB design. The AOZ8001A ultra-low capacitance TVS is designed to protect four high speed data transmission lines from transient over-voltages by clamping them to a fixed reference. The low inductance and construction minimizes voltage overshoot during high current surges. When the voltage on the protected line exceeds the reference voltage the internal steering diodes are forward biased, conducting the transient current away from the sensitive circuitry.

Good circuit board layout is critical for the suppression of ESD induced transients. The following guidelines are recommended:

1. Place the TVS near the IO terminals or connectors to restrict transient coupling.
2. Fill unused portions of the PCB with ground plane.
3. Minimize the path length between the TVS and the protected line.
4. Minimize all conductive loops including power and ground loops.
5. The ESD transient return path to ground should be kept as short as possible.
6. Never run critical signals near board edges.
7. Use ground planes whenever possible.
8. Avoid running critical signal traces (clocks, resets, etc.) near PCB edges.
9. Separate chassis ground traces from components and signal traces by at least 4mm.
10. Keep the chassis ground trace length-to-width ratio <5:1 to minimize inductance.
11. Protect all external connections with TVS diodes.

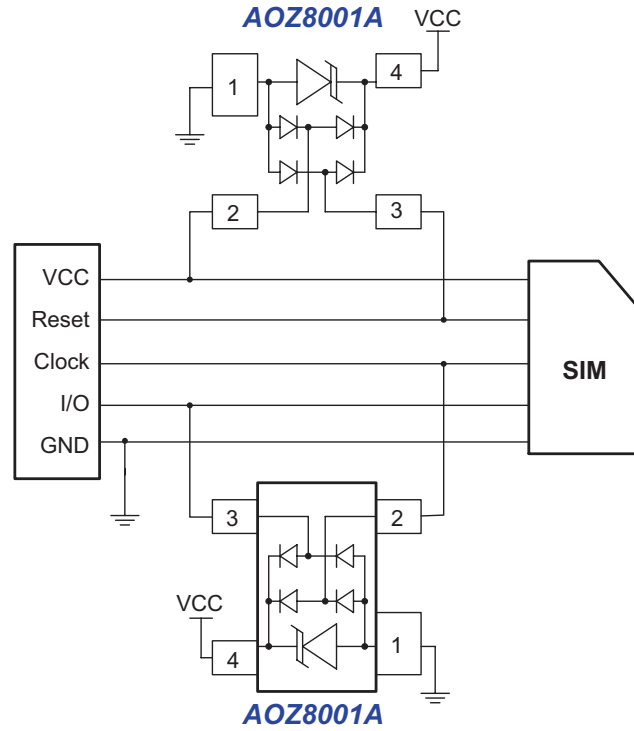

SIM Card Port Connection

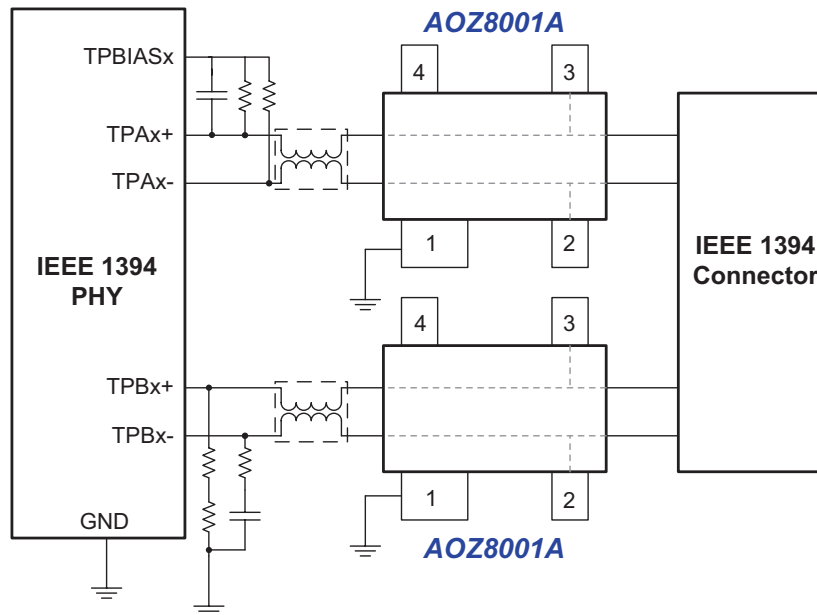

IEEE1394 Port Connection

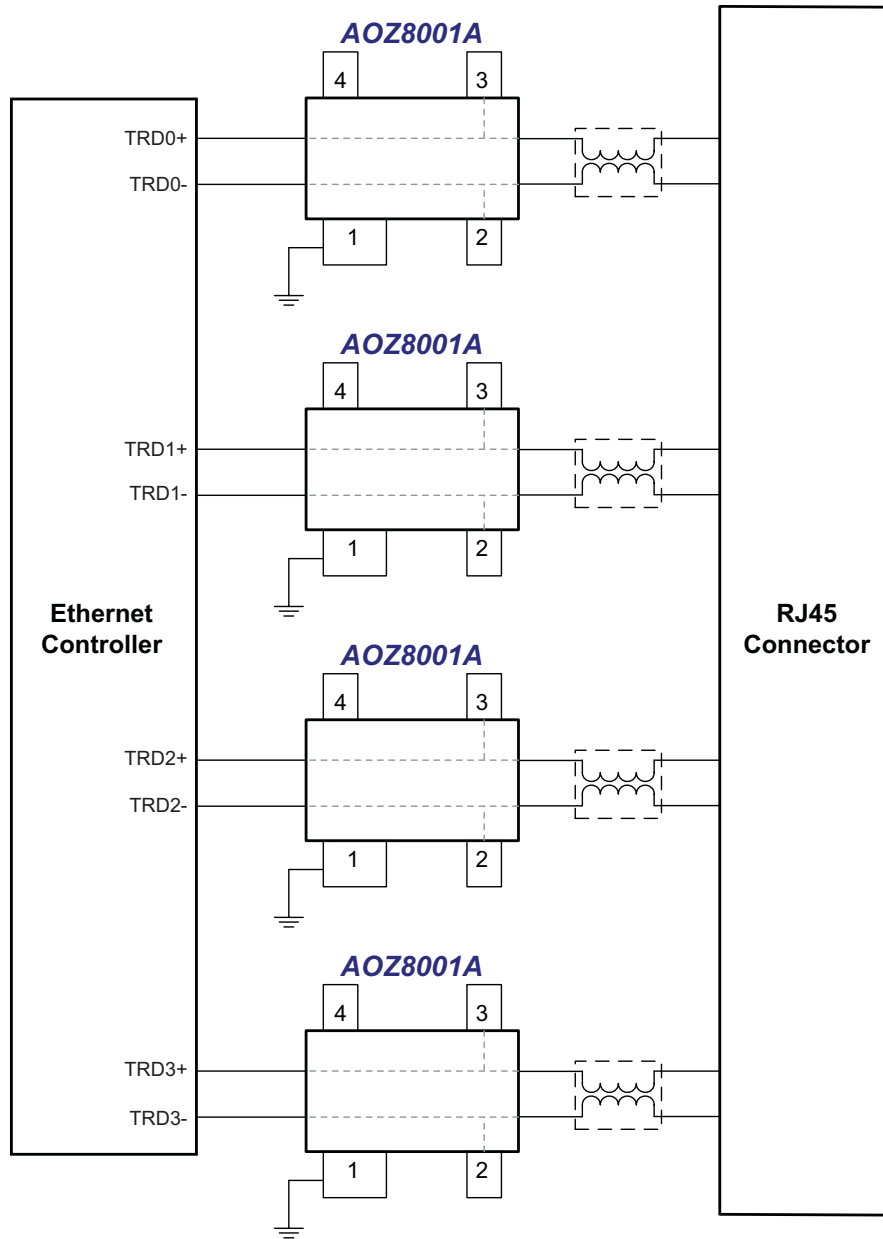

10/100 Ethernet Port Connection

Package Dimensions, SOT143-4L

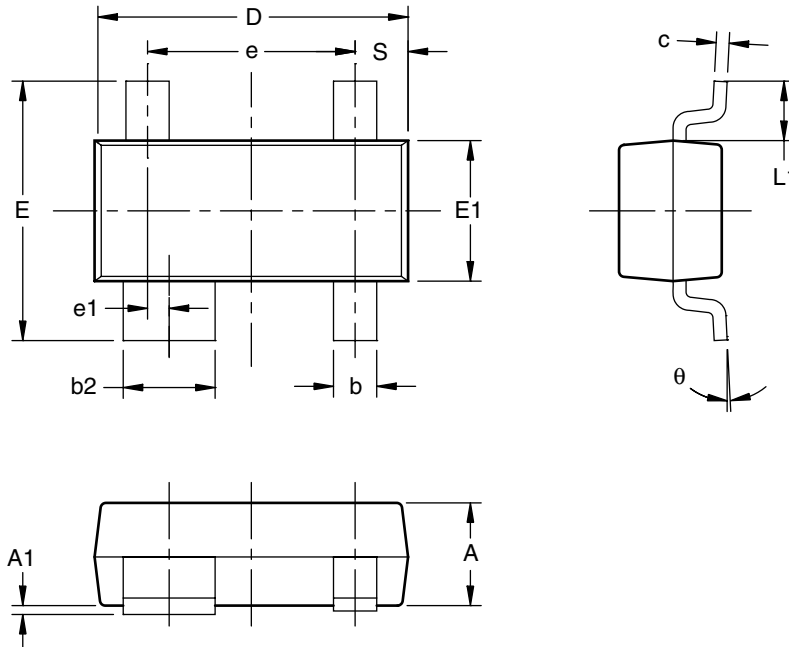

RECOMMENDED LAND PATTERN

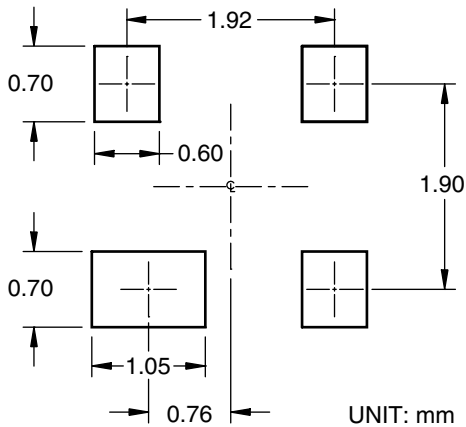

Dimensions in millimeters

Symbols	Min.	Nom.	Max.
A	0.890	—	1.120
A1	0.013	—	0.100
b	0.370	—	0.510
b2	0.760	—	0.940
c	0.085	—	0.180
D	2.800	—	3.040
E	2.100	—	2.640
E1	1.200	—	1.400
e	1.920 BSC		
e1	0.200 BSC		
L1	0.550 REF		
S	0.450	—	0.600
θ	0°	—	8°

Dimensions in inches

Symbols	Min.	Nom.	Max.
A	0.035	—	0.044
A1	0.001	—	0.004
b	0.015	—	0.020
b2	0.030	—	0.037
c	0.003	—	0.007
D	0.110	—	0.120
E	0.083	—	0.104
E1	0.047	—	0.055
e	0.076 BSC		
e1	0.008 BSC		
L1	0.022 REF		
S	0.018	—	0.024
θ	0°	—	8°

Notes:

1. All dimensions are in millimeters.
2. Tolerances are 0.10mm unless otherwise specified.
3. Package body sizes exclude mold flash and gate burrs.
4. Controlling dimension is millimeter, converted inch dimensions are not necessarily exact.

Tape and Reel Dimensions, SOT143-4L

Tape

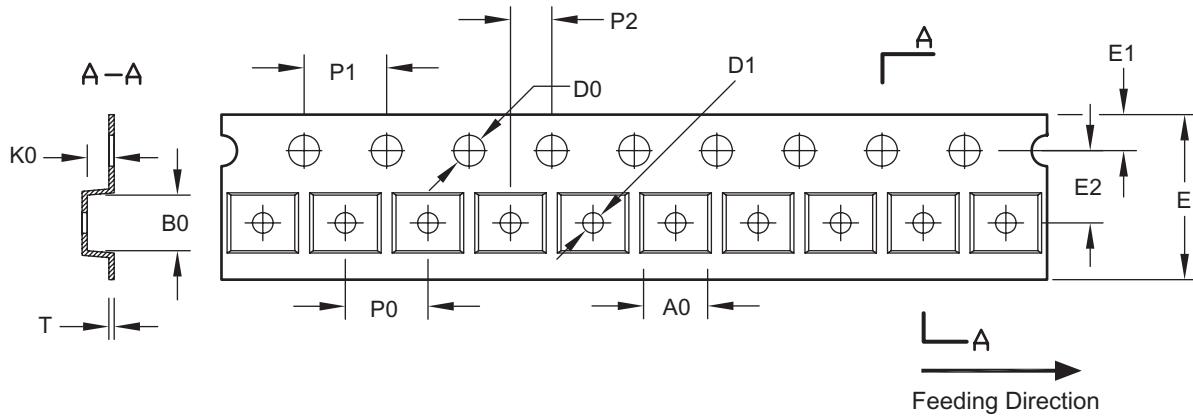

UNIT: mm

Package	A0	B0	K0	D0	D1	E	E1	E2	P0	P1	P2	T
SOT-143	3.10 ±0.10	2.69 ±0.10	1.30 ±0.10	1.50 ±0.10	1.00 +0.25/-0.00	8.00 +0.30/-0.10	1.75 ±0.10	3.50 ±0.05	4.00 ±0.10	4.00 ±0.10	2.00 ±0.05	0.254 ±0.013

Reel

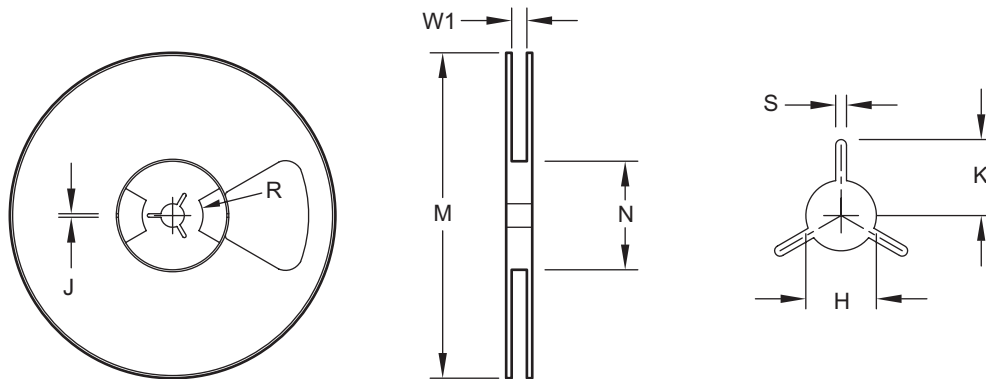

UNIT: mm

Tape Size	Reel Size	M	N	W1	H	S	K	R	J
8mm	ø177.8	ø177.8 Max.	55.0 Min.	8.4 +1.50 / -0.0	13.0 +0.5 / -0.2	1.5 Min.	10.1 Min.	12.7	4.0 ±0.1

Leader/Trailer and Orientation

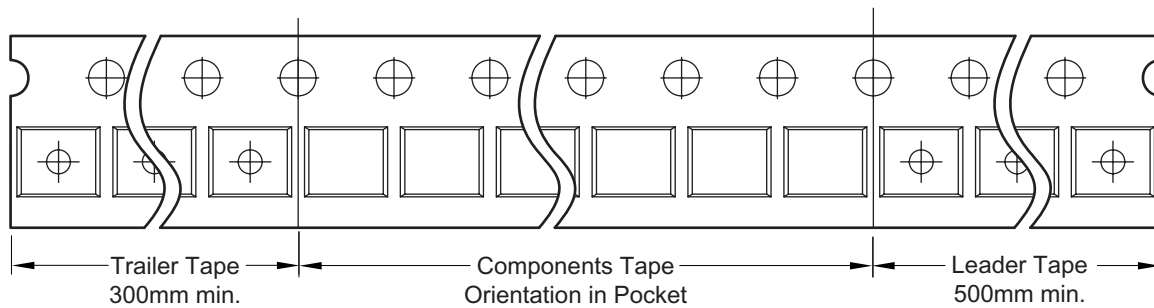

Part Marking

AOZ8001AJI (SOT-143)

Top Marking

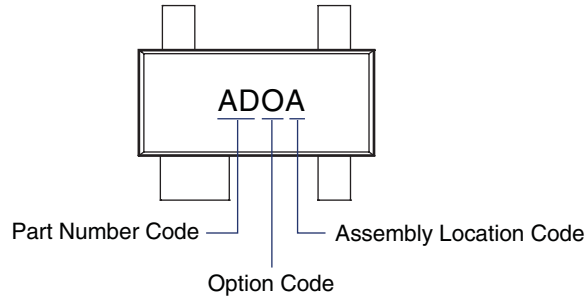

Bottom Marking

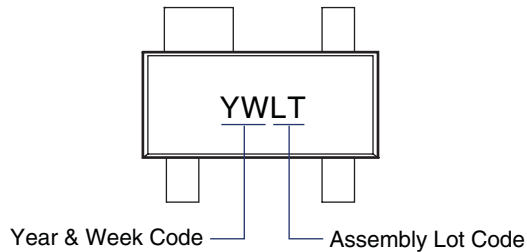

This datasheet contains preliminary data; supplementary data may be published at a later date. Alpha & Omega Semiconductor reserves the right to make changes at any time without notice.

LIFE SUPPORT POLICY

ALPHA & OMEGA SEMICONDUCTOR PRODUCTS ARE NOT AUTHORIZED FOR USE AS CRITICAL COMPONENTS IN LIFE SUPPORT DEVICES OR SYSTEMS.

As used herein:

1. Life support devices or systems are devices or systems which, (a) are intended for surgical implant into the body or (b) support or sustain life, and (c) whose failure to perform when properly used in accordance with instructions for use provided in the labeling, can be reasonably expected to result in a significant injury of the user.
2. A critical component in any component of a life support, device, or system whose failure to perform can be reasonably expected to cause the failure of the life support device or system, or to affect its safety or effectiveness.