



Chipsmall Limited consists of a professional team with an average of over 10 year of expertise in the distribution of electronic components. Based in Hongkong, we have already established firm and mutual-benefit business relationships with customers from,Europe,America and south Asia,supplying obsolete and hard-to-find components to meet their specific needs.

With the principle of “Quality Parts,Customers Priority,Honest Operation,and Considerate Service”,our business mainly focus on the distribution of electronic components. Line cards we deal with include Microchip,ALPS,ROHM,Xilinx,Pulse,ON,Everlight and Freescale. Main products comprise IC,Modules,Potentiometer,IC Socket,Relay,Connector.Our parts cover such applications as commercial,industrial, and automotives areas.

We are looking forward to setting up business relationship with you and hope to provide you with the best service and solution. Let us make a better world for our industry!



Contact us

Tel: +86-755-8981 8866 Fax: +86-755-8427 6832

Email & Skype: info@chipsmall.com Web: www.chipsmall.com

Address: A1208, Overseas Decoration Building, #122 Zhenhua RD., Futian, Shenzhen, China



General Description

The AOZ8235 is a transient voltage suppressor diode array designed to protect data lines from high transient conditions and ESD. This state-of-the-art device utilizes AOS leading edge Trench Vertical Structure [TVS]²™ technology for superior clamping performance.

This device incorporates five TVS diodes in a single package. Due to the flexibility of the design, the package can be configured as a four channel bidirectional TVS array. During transient conditions, the TVS diodes direct the transient to ground. They may be used to meet the ESD immunity requirements of IEC 61000-4-2, Level 4 (±15 kV air, ±8 kV contact discharge).

The AOZ8235 comes in an RoHS compliant DFN package and is rated over a -40 °C to +85 °C ambient temperature range.

The very small 1.45 mm x 1.0 mm x 0.55 mm DFN package makes it ideal for applications where PCB space is a premium. The small size and high ESD protection makes it ideal for protecting high speed video and data communication interfaces.

Features

- ESD protection for high-speed data lines:
 - Exceeds: IEC 61000-4-2 (ESD) ±18 kV (air), ±18 kV (contact)
 - Human Body Model (HBM) ±30 kV
- Trench Vertical Structure [TVS]²™ based technology used to achieve excellent ESD clamping performance
- Small package saves board space
- Low insertion loss
- Protects five unidirectional or four bidirectional I/O lines
- Low clamping voltage
- Low operating voltage: 5.0V
- Green product, Pb-free

Applications

- Portable handheld devices
- Keypads, data lines
- Notebook computers
- Digital cameras
- Portable GPS
- MP3 players



Typical Applications

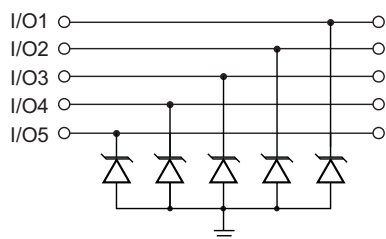

Unidirection Protection of Five Lines

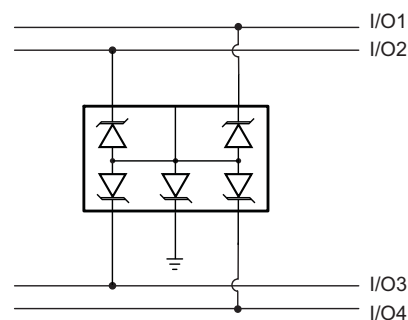

Bidirection Protection of Four Lines

Pin Configuration

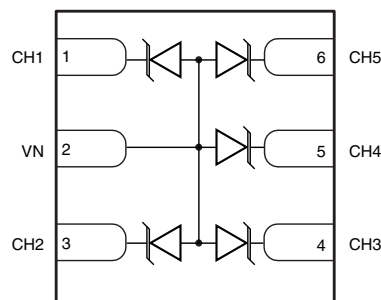

Top View

Ordering Information

Part Number	Ambient Temperature Range	Package	Environmental
AOZ8235DI-05	-40 °C to +85 °C	DFN 1.45 x 1.0	Green Product RoHS Compliant



AOS Green Products use reduced levels of Halogens, and are also RoHS compliant.

Please visit www.aosmd.com/media/AOSGreenPolicy.pdf for additional information.

Absolute Maximum Ratings

Exceeding the Absolute Maximum ratings may damage the device.

Parameter	Rating
VP – VN	5 V
Peak Pulse Current (I_{PP}), $t_P = 8/20 \mu s$	4 A
Storage Temperature (T_S)	-65 °C to +150 °C
ESD Rating per IEC61000-4-2, Contact ⁽¹⁾	±18 kV
ESD Rating per IEC61000-4-2, Air ⁽¹⁾	±18 kV
ESD Rating per Human Body Model ⁽²⁾	±30 kV

Notes:

- IEC 61000-4-2 discharge with $C_{Discharge} = 150 \text{ pF}$, $R_{Discharge} = 330 \Omega$.
- Human Body Discharge per MIL-STD-883, Method 3015 $C_{Discharge} = 100 \text{ pF}$, $R_{Discharge} = 1.5 \text{ k}\Omega$.

Maximum Operating Ratings

Parameter	Rating
Junction Temperature (T_J)	-40 °C to +125 °C

Electrical Characteristics

$T_A = 25^\circ\text{C}$ unless otherwise specified.

Symbol	Parameter	Conditions	Min.	Typ.	Max.	Units
V_{RWM}	Reverse Working Voltage	Between pin 5 and 2 ⁽³⁾			5.0	V
V_{BR}	Reverse Breakdown Voltage	$I_T = 1 \text{ mA}$, between pins 5 and 2 ⁽⁴⁾	6.0			V
I_R	Reverse Leakage Current	$V_{RWM} = 5 \text{ V}$, any I/O pin to Ground			0.1	μA
V_F	Diode Forward Voltage	$I_F = 10 \text{ mA}$, any I/O pin to Ground		0.7		V
V_{CL}	Channel Clamp Voltage Positive Transients Negative Transient	$I_{PP} = 15 \text{ A}$, $t_P = 100 \text{ ns}$, any I/O pin to Ground			12.0	V
					-10.0	V
V_{CL}	Channel Clamp Voltage Positive Transients Negative Transient	$I_{PP} = 25 \text{ A}$, $t_P = 100 \text{ ns}$, any I/O pin to Ground			15.0	V
					-18.0	V
C_j	Junction Capacitance	$V_R = 0 \text{ V}$, $f = 1 \text{ MHz}$, any I/O pin to Ground		13.5	16.0	pF

Notes:

- The working peak reverse voltage, V_{RWM} , should be equal to or greater than the DC or continuous peak operating voltage level.
- V_{BR} is measured at the pulse test current I_T .

Typical Performance Characteristics

Clamping Voltage vs. Peak Pulse Current
(tperiod = 100ns, tr = 1ns)

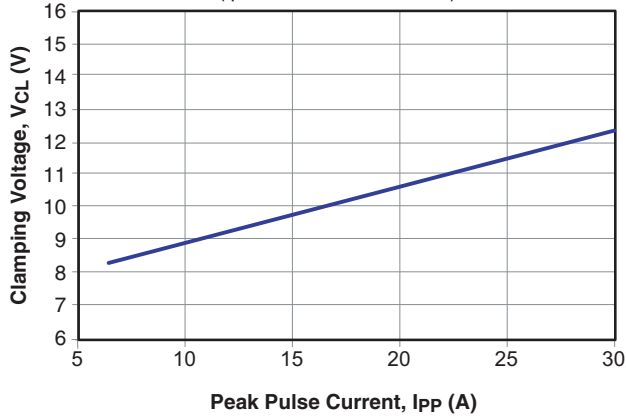

Clamping Voltage vs. Current
(tperiod = 100ns, tr = 1ns)

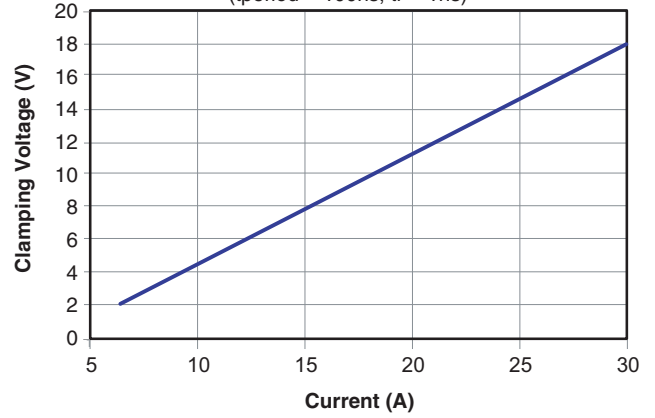

Capacitance vs. Reverse Bias

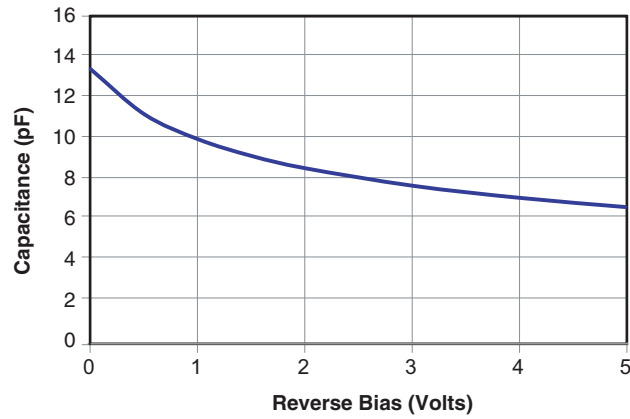

Applications Information

Device Connection for Protection of Five Unidirectional Data Lines

These devices are designed to protect up to five unidirectional data lines. The device is connected as follows.

- Unidirectional protection of five I/O lines is achieved by connecting pins 1, 3, 4, 5 and 6 to the data lines. Connect pin 2 to ground. The ground connection should be made directly to the ground plane for best results. The path length is kept as short as possible to reduce the effects of parasitic inductance in the board traces.

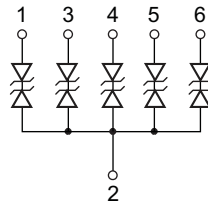

Circuit Diagram

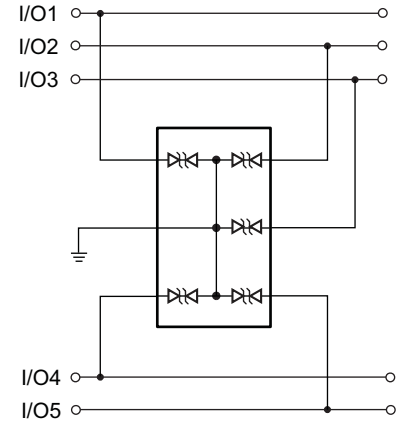

Protection of Five Unidirectional Lines

Device Connection for Protection of Four Bidirectional Data Lines

These devices are designed to protect up to four bidirectional data lines. The device is connected as follows.

- Bidirectional protection of four I/O lines is achieved by connecting pins 1, 3, 4, and 6 to the data lines. Connect pin 5 to ground. The ground connection should be made directly to the ground plane for best results. The path length is kept as short as possible to reduce the effects of parasitic inductance in the board traces.

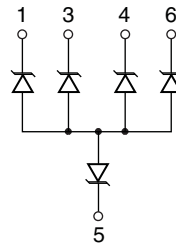

Circuit Diagram

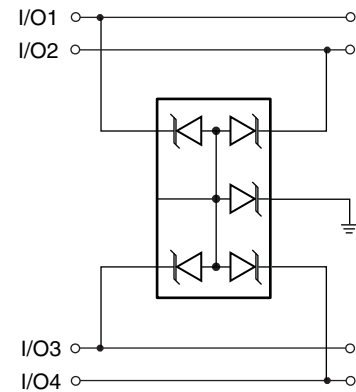

Protection of Four Bidirectional Lines

Circuit Board Layout Recommendations for Suppression of ESD

Good circuit board layout is critical for the suppression of ESD induced transients. The following guidelines are recommended:

- Place the TVS near the input terminals or connectors to restrict transient coupling.
- Minimize the path length between the TVS and the protected line.
- Minimize all conductive loops including power and ground loops.
- The ESD transient return path to ground should be kept as short as possible.
- Never run critical signals near board edges.
- Use ground planes whenever possible.

Package Dimensions, DFN 1.45 x 1.0, 6L

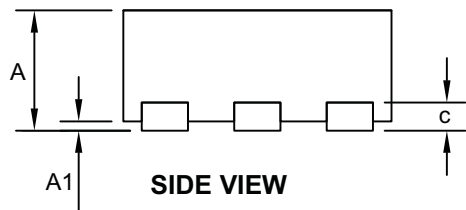
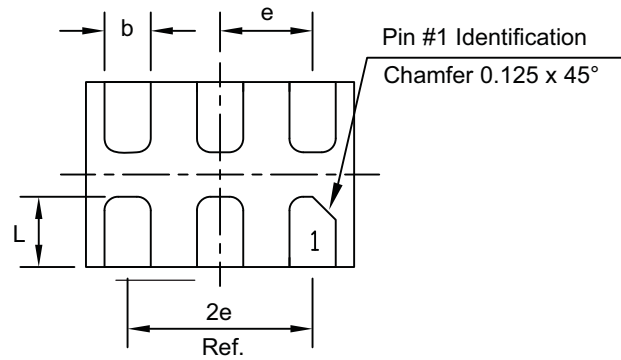
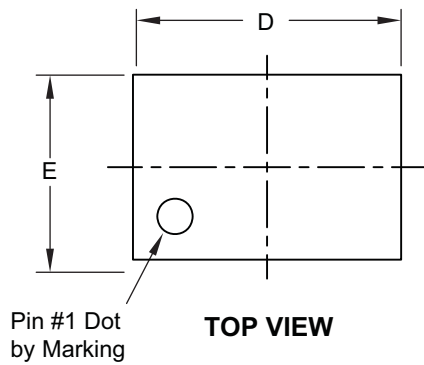

RECOMMENDED LAND PATTERN

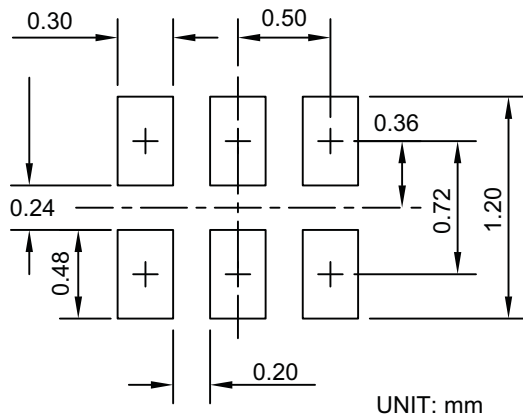

Dimensions in millimeters

Symbols	Min.	Nom.	Max.
A	0.50	0.55	0.60
A1	0.00	—	0.05
b	0.20	0.25	0.30
c	0.152 Ref.		
D	1.40	1.45	1.50
E	0.95	1.00	1.05
e	0.50 BSC		
L	0.33	0.38	0.43

Dimensions in inches

Symbols	Min.	Nom.	Max.
A	0.020	0.022	0.024
A1	0.000	—	0.002
b	0.008	0.010	0.012
c	0.006 Ref.		
D	0.055	0.057	0.059
E	0.038	0.040	0.042
e	0.020 BSC		
L	0.013	0.015	0.017

Part Marking

AOZ8235DI-05
(DFN 1.45 x 1.0)

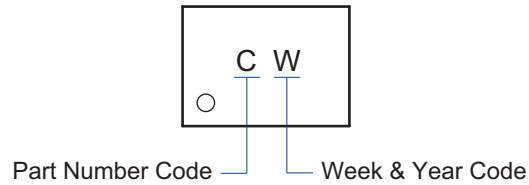

LEGAL DISCLAIMER

Alpha and Omega Semiconductor makes no representations or warranties with respect to the accuracy or completeness of the information provided herein and takes no liabilities for the consequences of use of such information or any product described herein. Alpha and Omega Semiconductor reserves the right to make changes to such information at any time without further notice. This document does not constitute the grant of any intellectual property rights or representation of non-infringement of any third party's intellectual property rights.

LIFE SUPPORT POLICY

ALPHA AND OMEGA SEMICONDUCTOR PRODUCTS ARE NOT AUTHORIZED FOR USE AS CRITICAL COMPONENTS IN LIFE SUPPORT DEVICES OR SYSTEMS.

As used herein:

1. Life support devices or systems are devices or systems which, (a) are intended for surgical implant into the body or (b) support or sustain life, and (c) whose failure to perform when properly used in accordance with instructions for use provided in the labeling, can be reasonably expected to result in a significant injury of the user.
2. A critical component in any component of a life support, device, or system whose failure to perform can be reasonably expected to cause the failure of the life support device or system, or to affect its safety or effectiveness.