



Chipsmall Limited consists of a professional team with an average of over 10 year of expertise in the distribution of electronic components. Based in Hongkong, we have already established firm and mutual-benefit business relationships with customers from,Europe,America and south Asia,supplying obsolete and hard-to-find components to meet their specific needs.

With the principle of “Quality Parts,Customers Priority,Honest Operation,and Considerate Service”,our business mainly focus on the distribution of electronic components. Line cards we deal with include Microchip,ALPS,ROHM,Xilinx,Pulse,ON,Everlight and Freescale. Main products comprise IC,Modules,Potentiometer,IC Socket,Relay,Connector.Our parts cover such applications as commercial,industrial, and automotives areas.

We are looking forward to setting up business relationship with you and hope to provide you with the best service and solution. Let us make a better world for our industry!



Contact us

Tel: +86-755-8981 8866 Fax: +86-755-8427 6832

Email & Skype: info@chipsmall.com Web: www.chipsmall.com

Address: A1208, Overseas Decoration Building, #122 Zhenhua RD., Futian, Shenzhen, China



AOZ8809 General Description

The AOZ8809 is a transient voltage suppressor array designed to protect high speed data lines such as HDMI 1.4/2.0, USB 3.0/3.1, MDDI, SATA, and Gigabit Ethernet from damaging ESD events.

This device incorporates eight surge rated, low capacitance steering diodes and a TVS in a single package. During transient conditions, the steering diodes direct the transient to either the positive side of the power supply line or to ground.

The AOZ8809 provides a typical line-to-line capacitance of 0.25 pF and low insertion loss up to 6 GHz providing greater signal integrity making it ideally suited for HDMI 1.4/2.0 or USB 3.0/3.1 applications, such as Digital TVs, DVD players, computing, set-top boxes and MDDI applications in mobile computing devices.

The AOZ8809 comes in a RoHS compliant and Halogen Free 2.5 mm x 1.0 mm x 0.55 mm DFN-10 package and is rated for -40 °C to +85 °C junction temperature range.

Features

- ESD protection for high-speed data lines:
 - IEC 61000-4-2, level 4 (ESD) immunity test
 - Air discharge: ±15 kV; contact discharge: ±15 kV
 - IEC61000-4-4 (EFT) 40 A (5/50 nS)
 - IEC61000-4-5 (Lightning) 4 A (8/20 μS)
 - Human Body Model (HBM) ±24 kV
- Array of surge rated diodes with internal TVS diode
- Small package saves board space
- Protects four I/O lines
- Low capacitance between I/O lines: 0.25 pF
- Low clamping voltage
- Low operating voltage: 3.3V, 5.0 V

Applications

- HDMI 1.4/2.0, USB 3.0/3.1, MDDI, SATA ports
- Monitors and flat panel displays
- Set-top box
- Video graphics cards
- Digital Video Interface (DVI)
- Notebook computers



Typical Applications

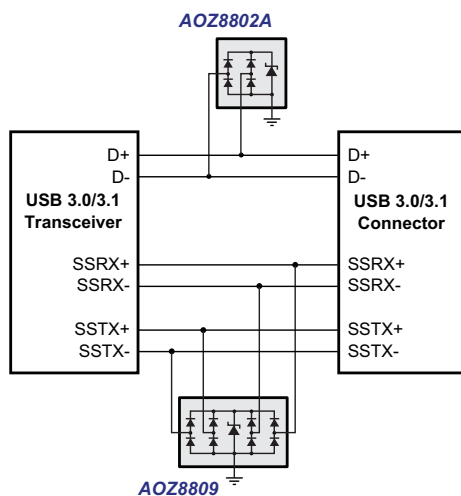

Figure 1. USB 3.0/3.1 Ports

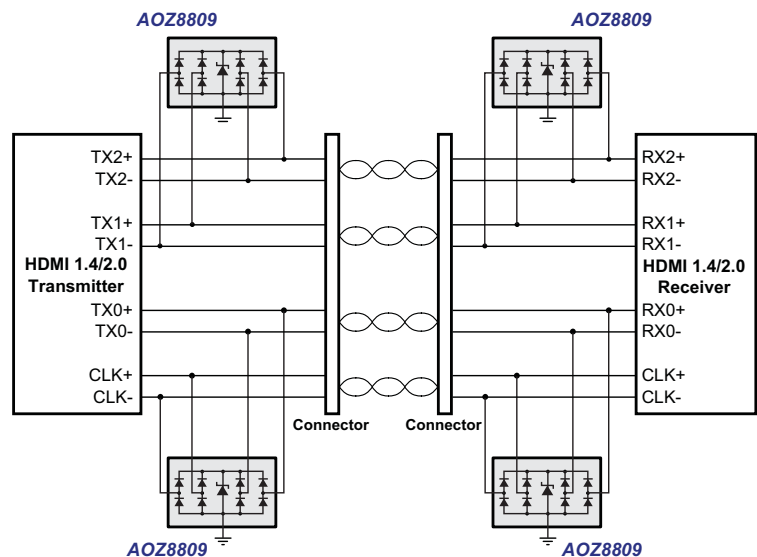

Figure 2. HDMI 1.4/2.0 Ports

Ordering Information

Part Number	Ambient Temperature Range	Package	Environmental
AOZ8809DI-03	-40 °C to +85 °C	2.5 mm x 1.0 mm x 0.55 mm DFN-10	Green Product
AOZ8809DI-05			



AOS Green Products use reduced levels of Halogens, and are also RoHS compliant. Please visit www.aosmd.com/media/AOSGreenPolicy.pdf for additional information.

Pin Configuration

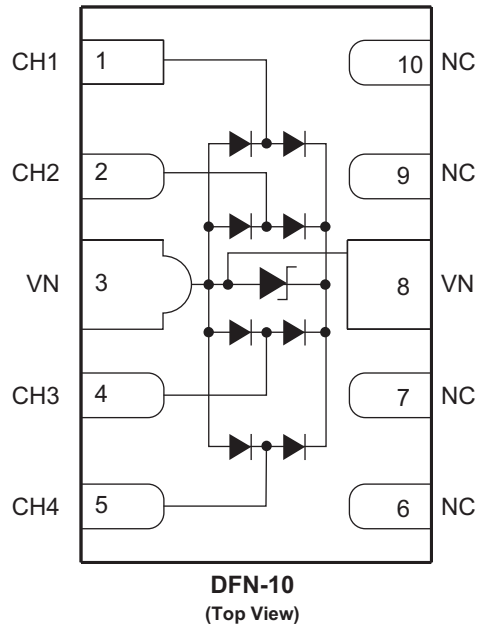

Absolute Maximum Ratings

Exceeding the Absolute Maximum ratings may damage the device.

Parameter	AOZ8809DI-03	AOZ8809DI-05
Storage Temperature (T_S)	-65 °C to +150 °C	
ESD Rating per IEC61000-4-2, contact ⁽¹⁾⁽³⁾	±15 kV	
ESD Rating per IEC61000-4-2, air ⁽¹⁾⁽³⁾	±15 kV	
ESD Rating per Human Body Model ⁽²⁾⁽³⁾	±24 kV	

Notes:

- IEC 61000-4-2 discharge with $C_{Discharge} = 150\text{pF}$, $R_{Discharge} = 330\ \Omega$.
- Human Body Discharge per MIL-STD-883, Method 3015 $C_{Discharge} = 100\ \text{pF}$, $R_{Discharge} = 1.5\ \text{k}\Omega$.

Maximum Operating Ratings

Parameter	Rating
Junction Temperature (T_J)	-40 °C to +125 °C

Electrical Characteristics

$T_A = 25^\circ\text{C}$ unless otherwise specified.

Symbol	Parameter	Diagram
I_{PP}	Maximum Reverse Peak Pulse Current	
V_{CL}	Clamping Voltage @ I_{PP} 100ns Transmission Line Pulse (TLP)	
V_{ESD}	ESD Clamping Voltage (IEC61000-4-2 +6kV Contact Discharge)	
V_{RWM}	Working Peak Reverse Voltage	
I_R	Maximum Reverse Leakage Current	
V_{BR}	Breakdown Voltage	
I_T	Test Current	
V_F	Forward Voltage @ I_F	
C_J	Max. Capacitance @ $V_R = 0$ and $f = 1$ MHz	

Device	Device Marking	V_{RWM} (V) Max.	V_{BR} (V) Min. $I_T = 100 \mu\text{A}$	I_R (μA) Max.	V_F (V) Typ.	V_{CL} Max. ⁽³⁾		V_{ESD} (V) ⁽³⁾ Typ.	C_J (pF) ^(3,4)	
						$I_{PP} = 2$ A	$I_{PP} = 12$ A		Typ.	Max.
AOZ8809DI-03	H	3.3	3.5	1.0	0.85	3.5	8.0	8.0	0.45	0.6
AOZ8809DI-05	K	5.0	6.0	1.0	0.85	4.0	9.0	8.0	0.45	0.6

Notes:

3. These specifications are guaranteed by design and characterization.
4. $V_{PIN} 3,8 = 0\text{V}$, $V_{IN} = 2.5\text{V}$, $f = 1\text{MHz}$, $T = 25^\circ\text{C}$, any I/o pin to Ground.

Typical Performance Characteristics

Forward Voltage vs. Forward Peak Pulse Current
(tperiod = 100ns, tr = 1ns)

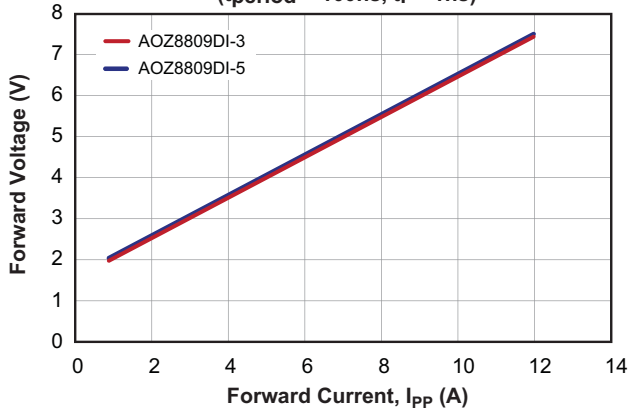

Clamping Voltage vs. Peak Pulse Current
(tperiod = 100ns, tr = 1ns)

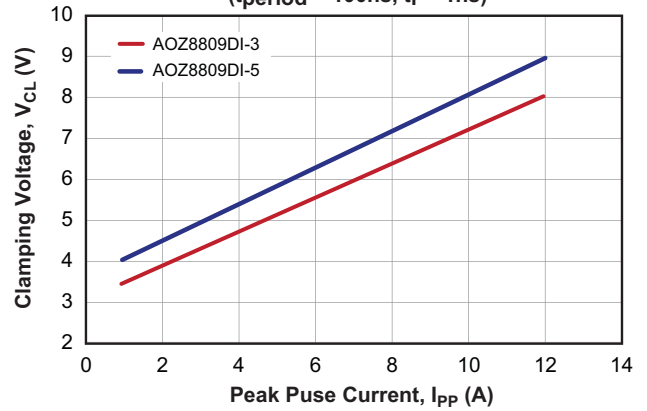

Typical Variation of CIN vs. VIN

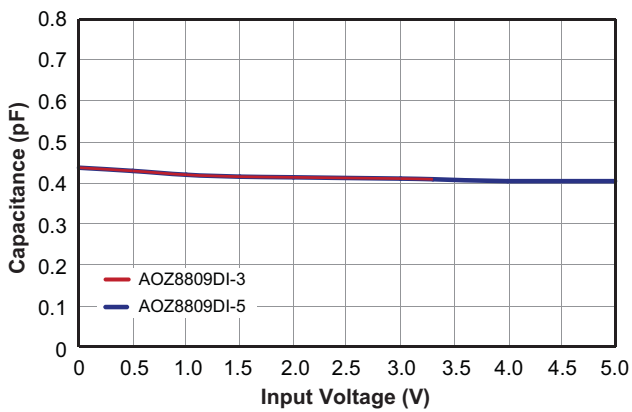

Capacitance vs. Frequency
(IO to GND)

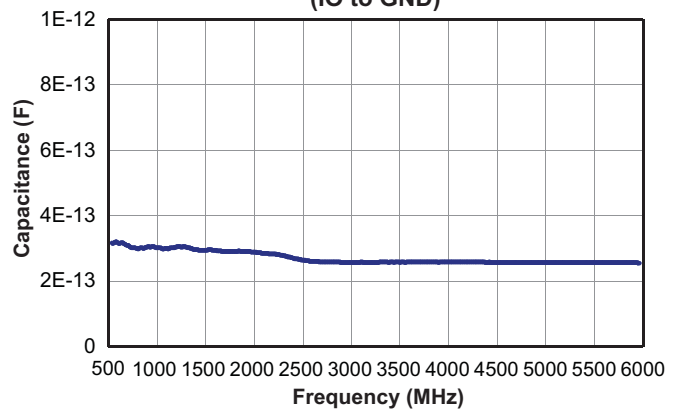

Transmission Line Pulsing (TLP) Measurement

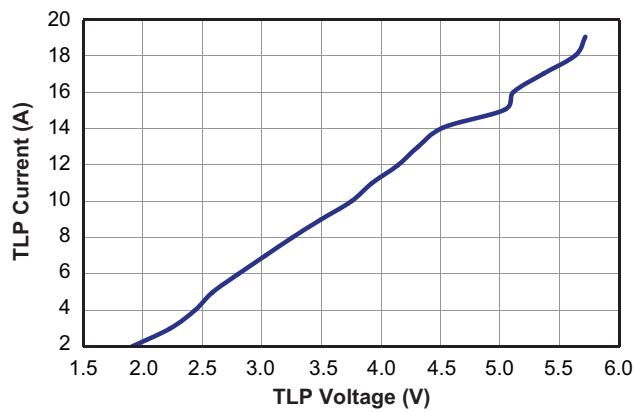

Typical Performance Characteristics (Continued)

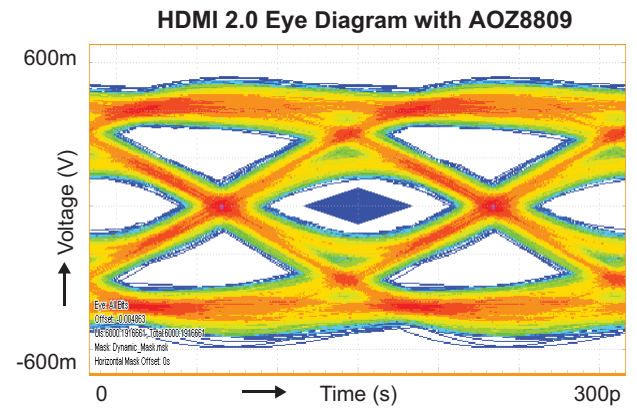
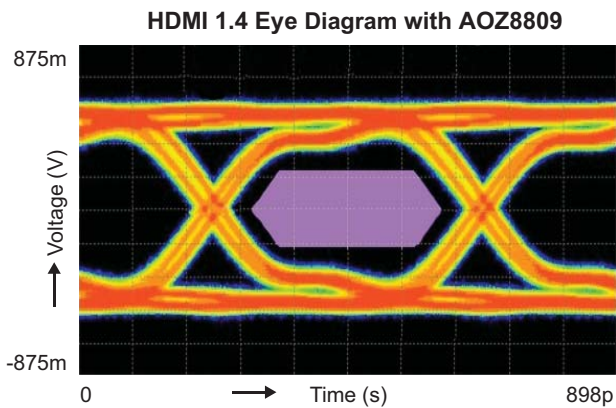
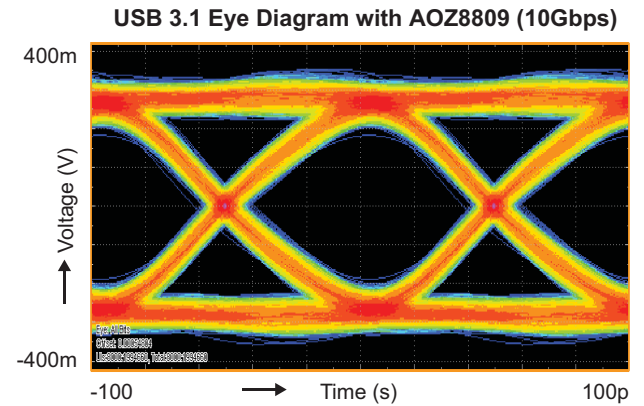
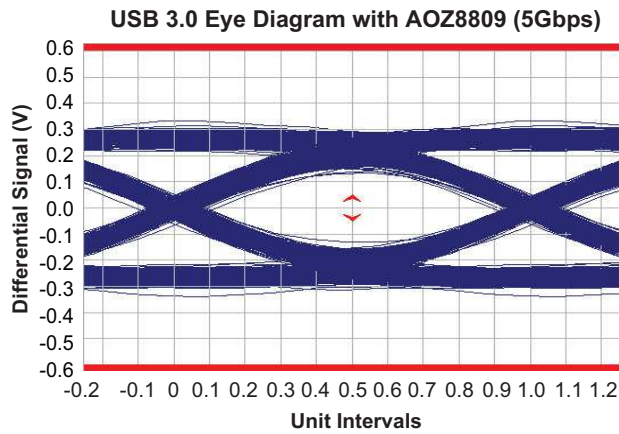
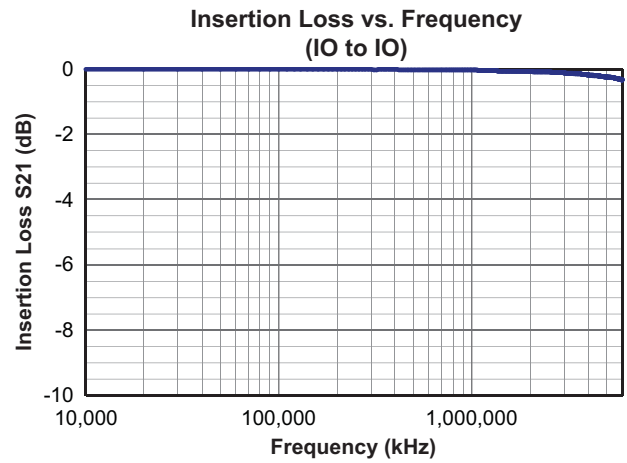
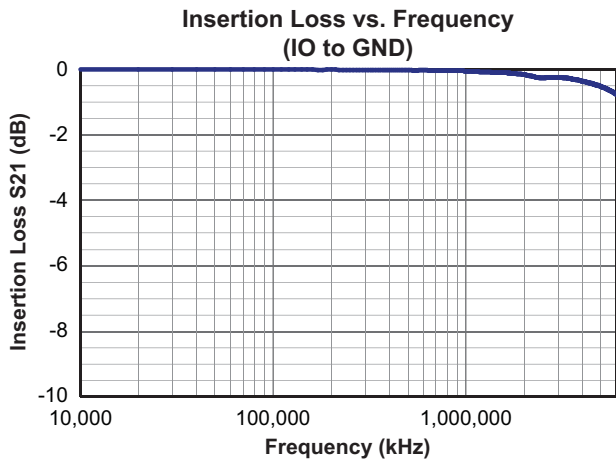

High Speed PCB Layout Guidelines

Printed circuit board layout is the key to achieving the highest level of surge immunity on power and data lines. The location of the protection devices on the PCB is the simplest and most important design rule to follow. The AOZ8809DI devices should be located as close as possible to the noise source. The AOZ8809DI device should be placed on all data and power lines that enter or exit the PCB at the I/O connector. In most systems, surge pulses occur on data and power lines that enter the PCB through the I/O connector. Placing the AOZ8809DI devices as close as possible to the noise source ensures that a surge voltage will be clamped before the pulse can be coupled into adjacent PCB traces. In addition, the PCB should use the shortest possible traces. A short trace length equates to low impedance, which ensures that the surge energy will be dissipated by the AOZ8809DI device. Long signal traces will act as antennas to receive energy from fields that are produced by the ESD pulse. By keeping line lengths as short as possible, the efficiency of the line to act as an antenna for ESD related fields is reduced. Minimize interconnecting line lengths by placing devices with the most interconnect as close together as possible. The protection circuits should shunt the surge voltage to either the reference or chassis ground. Shunting the surge voltage directly to the IC's signal ground can cause ground bounce. The clamping performance of TVS diodes on a single ground PCB can be improved by minimizing the impedance with

relatively short and wide ground traces. The PCB layout and IC package parasitic inductances can cause significant overshoot to the TVS's clamping voltage. The inductance of the PCB can be reduced by using short trace lengths and multiple layers with separate ground and power planes. One effective method to minimize loop problems is to incorporate a ground plane in the PCB design.

The AOZ8809DI ultra-low capacitance TVS is designed to protect four high speed data transmission lines from transient over-voltages by clamping them to a fixed reference. The low inductance and construction minimizes voltage overshoot during high current surges. When the voltage on the protected line exceeds the reference voltage the internal steering diodes are forward biased, conducting the transient current away from the sensitive circuitry. The AOZ8809DI is designed for ease of PCB layout by allowing the traces to run underneath the device. The pinout of the AOZ8809DI is designed to simply drop onto the IO lines of a High Definition Multimedia Interface (HDMI 1.4/2.0) or USB 3.0/3.1 design without having to divert the signal lines that may add more parasitic inductance. Pins 1, 2, 4 and 5 are connected to the internal TVS devices and pins 6, 7, 9 and 10 are no connects. The no connects was done so the package can be securely soldered onto the PCB surface.

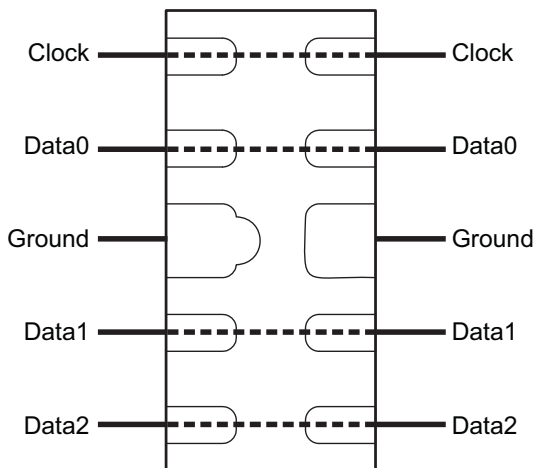

Figure 3. Flow Through Layout for HDMI 1.4/2.0

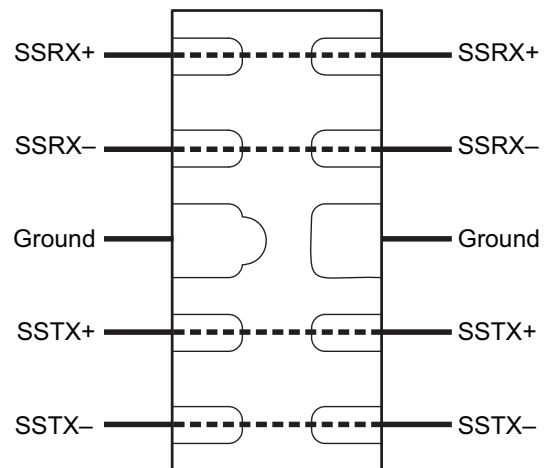
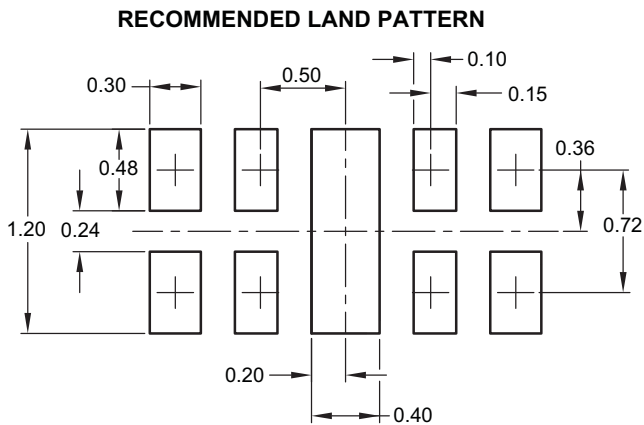
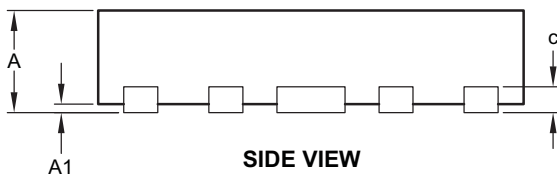
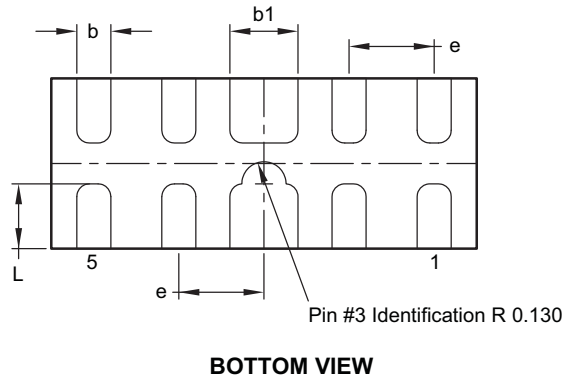
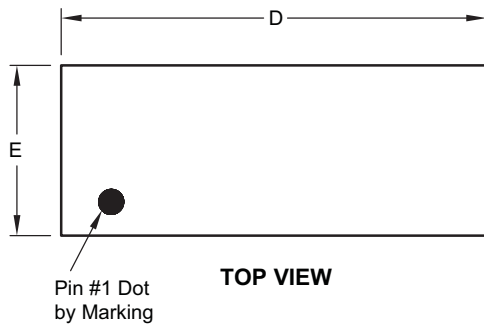

Figure 4. Flow Through Layout for USB 3.0/3.1

Package Dimensions, DFN 2.5mm x 1.0mm x 0.5mm, 10L



Dimensions in millimeters

Symbols	Min.	Nom.	Max.
A	0.50	0.55	0.60
A1	0.00	—	0.05
b	0.15	0.20	0.25
b1	0.40		
c	0.152 Ref.		
D	2.45	2.50	2.55
E	0.95	1.00	1.05
e	0.50 BSC		
L	0.33	0.38	0.43

Dimensions in inches

Symbols	Min.	Nom.	Max.
A	0.020	0.022	0.024
A1	0.000	—	0.002
b	0.006	0.008	0.010
b1	0.016		
c	0.006 Ref.		
D	0.096	0.098	0.100
E	0.037	0.039	0.041
e	0.020 BSC		
L	0.013	0.015	0.017

Note:

1. Controlling dimension is millimeter. Converted inch dimensions are not necessarily exact.

Tape and Reel Dimensions, DFN 2.5mm x 1.0mm x 0.5mm, 10L

Carrier Tape

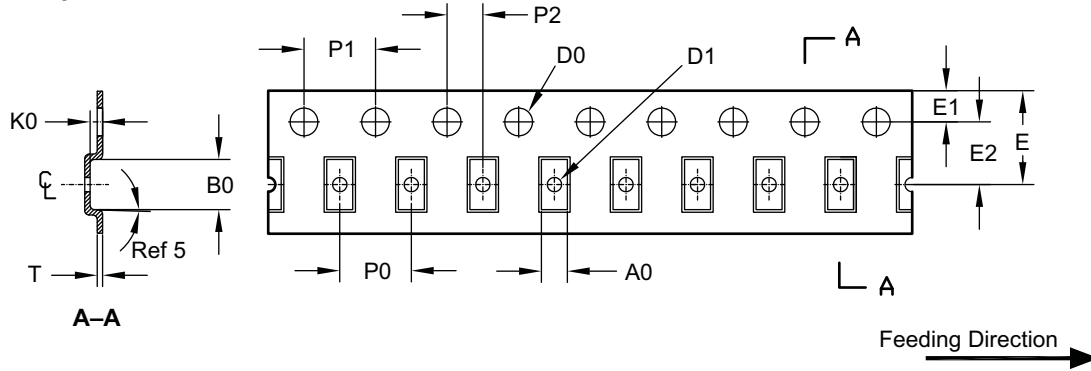

UNIT: mm

Package	A0	B0	K0	D0	D1	E	E1	E2	P0	P1	P2	T
DFN 2.5x1.0	1.12 0.05	2.62 0.05	0.70 0.05	ø1.55 0.05	ø0.55 0.05	8.00 +0.3/-0.1	1.75 0.1	3.50 0.05	4.00 0.10	4.0 0.10	2.0 0.05	0.25 0.05

Reel

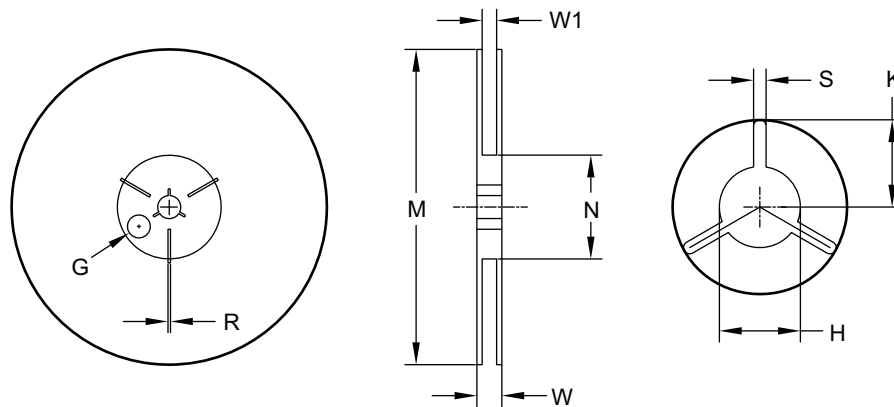

UNIT: mm

Tape Size	Reel Size	M	N	W	W1	H	S	K	E	R
8mm	ø178	ø178.0 1.0	ø60.0 0.5	11.80 0.5	9.0 0.5	ø13.0 +0.5 / -0.2	2.40 0.10	10.25 0.2	ø9.8	—

Leader / Trailer & Orientation

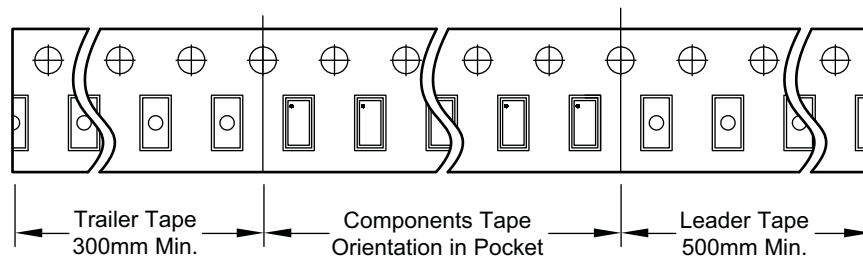

Part Marking

AOZ8809DI-03
(2.5 x 1.0 DFN)

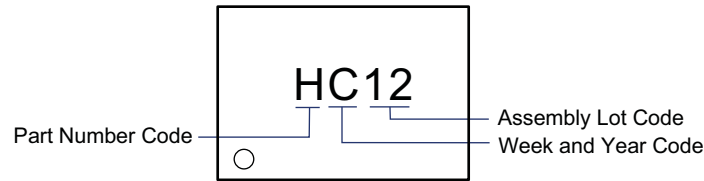

AOZ8809DI-05
(2.5 x 1.0 DFN)

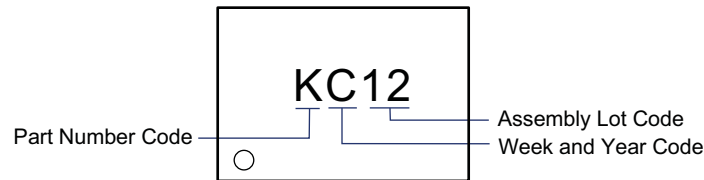

LEGAL DISCLAIMER

Alpha and Omega Semiconductor makes no representations or warranties with respect to the accuracy or completeness of the information provided herein and takes no liabilities for the consequences of use of such information or any product described herein. Alpha and Omega Semiconductor reserves the right to make changes to such information at any time without further notice. This document does not constitute the grant of any intellectual property rights or representation of non-infringement of any third party's intellectual property rights.

LIFE SUPPORT POLICY

ALPHA AND OMEGA SEMICONDUCTOR PRODUCTS ARE NOT AUTHORIZED FOR USE AS CRITICAL COMPONENTS IN LIFE SUPPORT DEVICES OR SYSTEMS.

As used herein:

- | | |
|-------------------------------------------------------------------------------------------------------------------------------------------------------------------------------------------------------------------------------------------------------------------------------------------------------------------------------------------------------------|-----------------------------------------------------------------------------------------------------------------------------------------------------------------------------------------------------------------------------------------------|
| <p>1. Life support devices or systems are devices or systems which, (a) are intended for surgical implant into the body or (b) support or sustain life, and (c) whose failure to perform when properly used in accordance with instructions for use provided in the labeling, can be reasonably expected to result in a significant injury of the user.</p> | <p>2. A critical component in any component of a life support, device, or system whose failure to perform can be reasonably expected to cause the failure of the life support device or system, or to affect its safety or effectiveness.</p> |
|-------------------------------------------------------------------------------------------------------------------------------------------------------------------------------------------------------------------------------------------------------------------------------------------------------------------------------------------------------------|-----------------------------------------------------------------------------------------------------------------------------------------------------------------------------------------------------------------------------------------------|